

CP 155

CP 155



REYNAERS
aluminium

Cat. nr. 34
Art. nr. AD.089.C34C.00*
Edition 02/2009

Inhoud

Sommaire

Content

Inhalt



- A Algemene informatie
Généralités
General Information
Allgemeine Information

- B Algemene informatie systemen
Généralités séries
General Information System
Allgemeine Information System

- C Profielen
Profilés
Profiles
Profile

- D Doorsnedetekeningen
Sections des noeuds
Section drawings
Profilkombinationen

- E Werktekeningen
Coupes et débits
Work drawings
Werkzeichnungen

- F Montagetekeningen
Fabrication et montage
Assembly drawings
Montagezeichnungen

- G Toebehoren
Accessoires
Accessories
Zubehör



INHOUDSTAFEL	34.001
INHOUDSTAFEL	34.002
INHOUDSTAFEL	34.003
INHOUDSTAFEL	34.004
INHOUDSTAFEL	34.005
INHOUDSTAFEL	34.006
INHOUDSTAFEL	34.007
INHOUDSTAFEL	34.008
INHOUDSTAFEL	34.009
INHOUDSTAFEL	34.010
INHOUDSTAFEL	34.011
INHOUDSTAFEL	34.012
INHOUDSTAFEL	34.013
INHOUDSTAFEL	34.014
INHOUDSTAFEL	34.015
INHOUDSTAFEL	34.016
INHOUDSTAFEL	34.017
INHOUDSTAFEL	34.018
INHOUDSTAFEL	34.019
INHOUDSTAFEL	34.020
INHOUDSTAFEL	34.021
INHOUDSTAFEL	34.022

Algemene informatie

SYMBOLENLIJST	34.A.001
SYMBOLENLIJST	34.A.002
SYMBOLENLIJST	34.A.003
SYMBOLENLIJST	34.A.004
SYMBOLENLIJST	34.A.005
SYMBOLENLIJST	34.A.006
SYMBOLENLIJST	34.A.007

Algemene informatie systemen

VERWERKINGSVOORSCHRIFTEN	34.B.001
VERWERKINGSVOORSCHRIFTEN	34.B.002
VERWERKINGSVOORSCHRIFTEN	34.B.003
VERWERKINGSVOORSCHRIFTEN	34.B.004

Profielen

PROFIELLIJST	34.C.p01
PROFIELLIJST	34.C.p02
PROFIELOVERZICHT	34.C.001
PROFIELOVERZICHT	34.C.002
PROFIELOVERZICHT	34.C.003
PROFIELOVERZICHT	34.C.004
PROFIELOVERZICHT	34.C.005
PROFIELOVERZICHT	34.C.006
GLASLATTEN	34.C.007
ROLLUIKGELEIDER	34.C.008
HULPPROFIELEN	34.C.009
BUITENKADERS	34.C.010
BUITENKADERS	34.C.011
BUITENKADER	34.C.012
BUITENKADER INBRAAKWEREND	34.C.013

BUITENKADER	34.C.014
BUITENKADERS MONORAIL	34.C.015
BUITENKADERS MONORAIL	34.C.016
AFDEKPROFIEL BUITENKADER MONORAIL	34.C.017
BUITENKADER 3-RAIL	34.C.018
BUITENKADER 3-RAIL	34.C.019
BUITENKADER 3-RAIL	34.C.020
VLEUGELS	34.C.021
VLEUGELS INBRAAKWEREND	34.C.022
HULPPROFIELEN VLEUGEL	34.C.023
HULPPROFIELEN VLEUGEL	34.C.024
VERSTERKINGSPROFIELEN VLEUGEL	34.C.025
T-PROFIELEN	34.C.026
T-PROFIELEN	34.C.027
T-PROFIELEN	34.C.028
T-PROFIELEN	34.C.029
WISSELPROFIEL	34.C.030
GLASLATTEN	34.C.031
GLASLATTEN	34.C.032
INBRAAKWEREND	34.C.033
INBRAAKWEREND	34.C.034
BEGLAZINGSTABEL	34.C.035
BEGLAZINGSTABEL	34.C.036
ROLLUIKGELEIDERS	34.C.037
ROLLUIKGELEIDERS	34.C.038
DILATATIEPROFIEL	34.C.039
KOPPELPROFIEL	34.C.040
HULPPROFIELEN	34.C.041
HULPPROFIELEN	34.C.042
HULPPROFIELEN	34.C.043
HULPPROFIELEN	34.C.044
AFDEKKAP MOTOR	34.C.045
2-RAIL XQ FLAT BOTTOM	34.C.046
2-RAIL XQ FLAT BOTTOM	

Doorsnedetekeningen

2-RAIL	34.D.001
2-RAIL	34.D.002
2-RAIL	34.D.003
2-RAIL	34.D.004
2-RAIL	34.D.005
2-RAIL	34.D.006
2-RAIL	34.D.007
2-RAIL	34.D.008
2-RAIL	34.D.009
2-RAIL	34.D.010
2-RAIL	34.D.011
2-RAIL	34.D.012
MONORAIL	34.D.013
MONORAIL	34.D.014
MONORAIL	34.D.015
MONORAIL	34.D.016
MONORAIL	34.D.017
MONORAIL	34.D.018
3-RAIL	34.D.019
3-RAIL	34.D.020
3-RAIL	34.D.021



3-RAIL	34.D.022	2-RAIL OXXO	34.E.025
3-RAIL	34.D.023	2-RAIL OXXO	34.E.026
2-RAIL	34.D.024	2-RAIL OXXO	34.E.027
2-RAIL	34.D.025	2-RAIL OXXO	34.E.028
2-RAIL	34.D.026	2-RAIL OXXO	34.E.029
2-RAIL	34.D.027	2-RAIL OXQ	34.E.030
2-RAIL	34.D.028	2-RAIL OXQ	34.E.031
2-RAIL	34.D.029	2-RAIL OXQ	34.E.032
2-RAIL	34.D.030	2-RAIL OXQ	34.E.033
2-RAIL	34.D.031	MONORAIL XQ	34.E.034
2-RAIL	34.D.032	MONORAIL XQ	34.E.035
2-RAIL	34.D.033	MONORAIL XQ	34.E.036
2-RAIL	34.D.034	MONORAIL XQ	34.E.037
2-RAIL	34.D.035	MONORAIL XQX	34.E.038
2-RAIL	34.D.036	MONORAIL XQX	34.E.039
MONORAIL	34.D.037	MONORAIL XQX	34.E.040
MONORAIL	34.D.038	MONORAIL XQX	34.E.041
MONORAIL	34.D.039	MONORAIL QXXQ	34.E.042
MONORAIL	34.D.040	MONORAIL QXXQ	34.E.043
MONORAIL	34.D.041	MONORAIL QXXQ	34.E.044
MONORAIL	34.D.042	MONORAIL QXXQ	34.E.045
MONORAIL	34.D.043	MONORAIL QXXQ	34.E.046
MONORAIL	34.D.044	MONORAIL QXXQ	34.E.047
3-RAIL	34.D.045	3-RAIL XXX	34.E.048
3-RAIL	34.D.046	3-RAIL XXX	34.E.049
3-RAIL	34.D.047	3-RAIL XXX	34.E.050
3-RAIL	34.D.048	3-RAIL XXX	34.E.051
3-RAIL	34.D.049	3-RAIL XXX	34.E.052
2-RAIL QXQ	34.D.050	3-RAIL XXX	34.E.053
2-RAIL FLAT BOTTOM	34.D.051	2-RAIL XQ	34.E.054
2-RAIL FLAT BOTTOM		2-RAIL XO	34.E.055
2-RAIL FLAT BOTTOM	34.D.052	2-RAIL XQ FLAT BOTTOM	34.E.056
		2-RAIL XQ FLAT BOTTOM	34.E.057
		2-RAIL XQ	34.E.058
		2-RAIL XO	34.E.059
		2-RAIL XQ FLAT BOTTOM	34.E.060
		2-RAIL XQ FLAT BOTTOM	34.E.061
		2-RAIL XX	34.E.062
		2-RAIL XX	34.E.063
		2-RAIL XX	34.E.064
		2-RAIL XX	34.E.065
		2-RAIL XX	34.E.066
		2-RAIL XX	34.E.067
		2-RAIL XQX	34.E.068
		2-RAIL XQX	34.E.069
		2-RAIL XQX	34.E.070
		2-RAIL XQX	34.E.071
		2-RAIL XQX	34.E.072
		2-RAIL XQX	34.E.073
		2-RAIL QXXQ	34.E.074
		2-RAIL QXXQ	34.E.075
		2-RAIL QXXQ	34.E.076
		2-RAIL QXXQ	34.E.077
		2-RAIL QXXQ	34.E.078
		2-RAIL QXXQ	34.E.079
		2-RAIL XXXX	34.E.080
		2-RAIL XXXX	34.E.081
		2-RAIL XXXX	34.E.082
		2-RAIL XXXX	34.E.083

Werktekeningen

2-RAIL XQ	34.E.001
2-RAIL XQ	34.E.002
2-RAIL XQ	34.E.003
2-RAIL XQ	34.E.004
2-RAIL XQ	34.E.005
2-RAIL XQ VARIANT HI	34.E.006
2-RAIL XQ VARIANT HI	34.E.007
2-RAIL XQ VARIANT HI	34.E.008
2-RAIL XQ VARIANT HI	34.E.009
2-RAIL XO	34.E.010
2-RAIL XO	34.E.011
2-RAIL XO	34.E.012
2-RAIL XO	34.E.013
2-RAIL XQX	34.E.014
2-RAIL XQX	34.E.015
2-RAIL XQX	34.E.016
2-RAIL XQX	34.E.017
2-RAIL QXXQ	34.E.018
2-RAIL QXXQ	34.E.019
2-RAIL QXXQ	34.E.020
2-RAIL QXXQ	34.E.021
2-RAIL QXXQ	34.E.022
2-RAIL QXXQ	34.E.023
2-RAIL OXXO	34.E.024



2-RAIL XXXX	34.E.084
2-RAIL XXXX	34.E.085
2-RAIL QXQ	34.E.086
2-RAIL QXQ	34.E.087
2-RAIL QXQ	34.E.088
2-RAIL QXQ	34.E.089
MONORAIL XQ	34.E.090
MONORAIL XQ	34.E.091
MONORAIL XQ	34.E.092
MONORAIL XQ	34.E.093
MONORAIL QXQ	34.E.094
MONORAIL QXQ	34.E.095
MONORAIL QXQ	34.E.096
MONORAIL QXQ	34.E.097
MONORAIL QXQ	34.E.098
MONORAIL QXQ	34.E.099
MONORAIL QXXQ	34.E.100
MONORAIL QXXQ	34.E.101
MONORAIL QXXQ	34.E.102
MONORAIL QXXQ	34.E.103
MONORAIL QXXQ	34.E.104
MONORAIL QXXQ	34.E.105
3-RAIL XXX	34.E.106
3-RAIL XXX	34.E.107
3-RAIL XXX	34.E.108
3-RAIL XXX	34.E.109
3-RAIL XXX	34.E.110
3-RAIL XXX	34.E.111
AUTOMATISCHE HEFSCHUIFDEUR	34.E.112
AUTOMATISCHE HEFSCHUIFDEUR	34.E.113
AUTOMATISCHE HEFSCHUIFDEUR	34.E.114
AUTOMATISCHE HEFSCHUIFDEUR	34.E.115
AUTOMATISCHE HEFSCHUIFDEUR	34.E.116

Montagetekeningen

HOEKVERBINDING	34.F.001
HOEKVERBINDING	34.F.002
HOEKVERBINDING	34.F.003
SCHROEFHOEKVERBINDING	34.F.004
SCHROEFHOEKVERBINDING	34.F.005
HOEKVERBINDING MONORAIL	34.F.006
HOEKVERBINDING MONORAIL	34.F.007
SCHROEFHOEKVERBINDING MONORAIL	34.F.008
SCHROEFHOEKVERBINDING MONORAIL	34.F.009
MONTAGE BUITENKADER	34.F.010
MONTAGE BUITENKADER	34.F.011
MONTAGE BUITENKADER MONORAIL	34.F.012
MONTAGE BUITENKADER MONORAIL	34.F.013
MONTAGE BUITENKADER 3-RAIL	34.F.014
MONTAGE BUITENKADER 3-RAIL	34.F.015
HOEKVERBINDING VLEUGEL	34.F.016
HOEKVERBINDING VLEUGEL	34.F.017
T-VERBINDINGEN	34.F.018
T-VERBINDINGEN	34.F.019
T-VERBINDER MET SCHROEF	34.F.020
T-VERBINDER MET NAGEL	34.F.021
T-VERBINDING MONORAIL	34.F.022
T-VERBINDING MONORAIL	34.F.023

T-VERBINDING MONORAIL	34.F.024
T-VERBINDING MONORAIL	34.F.025
MONTAGE AFDICHTING MET BORSTEL	34.F.026
MONTAGE AFDICHTING MET BORSTEL	34.F.027
MONTAGE SCHUIFVLEUGEL	34.F.028
MONTAGE SCHUIFVLEUGEL	34.F.029
INBOUW VEILIGHEIDSSLOT	34.F.030
INBOUW VEILIGHEIDSSLOT 4-RAIL	34.F.031
INBOUW 5-PUNTSSLUITING	34.F.032
INBOUW 5-PUNTSSLUITING	34.F.033
INBOUW BASISSET HEFSCHUIFDEUR	34.F.034
INBOUW BASISSET HEFSCHUIFDEUR	34.F.035
INBOUW BASISSET HEFSCHUIFDEUR 4-RAIL	34.F.036
INBOUW BASISSET HEFSCHUIFDEUR 4-RAIL	34.F.037
INBOUW BASISSET HEFSCHUIFDEUR 4-RAIL MIN. 300KG MAX. 400KG	34.F.038
INBOUW BASISSET HEFSCHUIFDEUR 4-RAIL MIN. 300KG MAX. 400KG	34.F.039
INBOUW BASISSET HEFSCHUIFDEUR 4-RAIL	34.F.040
INBOUW BASISSET HEFSCHUIFDEUR 4-RAIL	34.F.041
MONTAGE DEURKUK	34.F.042
MONTAGE DEURKUK	34.F.043
MONTAGE DEURKUK KABA	34.F.044
MONTAGE DEURKUK KABA	34.F.045
INBRAAKWEREND	34.F.046
INBRAAKWEREND	34.F.047
KOPPELING MET ANDERE SYSTEMEN	34.F.048
KOPPELING MET ANDERE SYSTEMEN	34.F.049
BEWERKEN MIDDENSTIJL 4-SLAG	34.F.050
BEWERKEN MIDDENSTIJL 4-SLAG	34.F.051
BEWERKEN MIDDENSTIJL 4-SLAG	34.F.052
BEWERKEN MIDDENSTIJL 4-SLAG	34.F.053
2-RAIL UITWERKING VLOERPROFIEL	34.F.054
2-RAIL UITWERKING VLOERPROFIEL	34.F.055
BEWERKEN MIDDENSTIJL 2-RAIL QXQ	34.F.056
BEWERKEN MIDDENSTIJL 2-RAIL QXQ	34.F.057
BUFFER	34.F.058
BUFFER	34.F.059
ONTWATERING VLEUGEL	34.F.060
DECOMPRESSIE VLEUGELS	34.F.061
ONTWATERING TYPE XQ XO QXQ	34.F.062
ONTWATERING TYPE XQ XO QXQ	34.F.063
ONTWATERING TYPE QXQ QXXQ OXXO	34.F.064
ONTWATERING TYPE QXQ QXXQ OXXO	34.F.065
ONTWATERING TYPE XQ XO QXQ	34.F.066
ONTWATERING TYPE XQ XO QXQ	34.F.067
ONTWATERING TYPE QXQ QXXQ OXXO	34.F.068
ONTWATERING TYPE QXQ QXXQ OXXO	34.F.069
ONTWATERING MONORAIL TYPE XQ	34.F.070
ONTWATERING MONORAIL TYPE XQ	34.F.071
ONTWATERING MONORAIL TYPE QXQ	34.F.072
ONTWATERING MONORAIL TYPE QXQ	34.F.073
ONTWATERING MONORAIL TYPE QXXQ	34.F.074
ONTWATERING MONORAIL TYPE QXXQ	34.F.075
ONTWATERING MONORAIL TYPE XQ	34.F.076
ONTWATERING MONORAIL TYPE XQ	34.F.077
ONTWATERING MONORAIL TYPE QXQ	34.F.078
ONTWATERING MONORAIL TYPE QXQ	34.F.079
ONTWATERING MONORAIL TYPE QXXQ	34.F.080
ONTWATERING MONORAIL TYPE QXXQ	34.F.081
ONTWATERING TYPE XXX XXQ	34.F.082
ONTWATERING TYPE XXX XXQ	34.F.083



ONTWATERING TYPE XXX XXQ	34.F.084
ONTWATERING TYPE XXX XXQ	34.F.085
KOPPELSTUK	34.F.086
KOPPELSTUK	34.F.087
GLASSTEUNEN	34.F.088
MONTAGE KLEMSTUK	34.F.089
MONTAGE 062.7927.04 / 062.8045.04	34.F.090
MONTAGE 062.7927.04 / 062.8045.04	34.F.091
MAX. TOELAATBARE AFMETINGEN VLEUGELS	34.F.092
MAX. TOELAATBARE AFMETINGEN VLEUGELS	34.F.093
MAX. TOELAATBARE AFMETINGEN VLEUGELS	34.F.094
MAX. TOELAATBARE AFMETINGEN VLEUGELS	34.F.095
MAX. TOELAATBARE AFMETINGEN VLEUGELS	34.F.096
MAX. TOELAATBARE AFMETINGEN VLEUGELS	34.F.097
MAX. TOELAATBARE LENGTEN VLEUGELS	34.F.098
MAX. TOELAATBARE AFMETINGEN VLEUGELS	34.F.099
MAX. TOELAATBARE AFMETINGEN VLEUGELS	34.F.100
MAX. TOELAATBARE AFMETINGEN VLEUGELS	34.F.101
MAX. TOELAATBARE AFMETINGEN VLEUGELS	34.F.102
MAX. TOELAATBARE AFMETINGEN VLEUGELS	34.F.103
BASISSET AUTOMATISCHE HEFSCHUIFDEUR	34.F.104
BASISSET AUTOMATISCHE HEFSCHUIFDEUR	34.F.105
ALGEMEEN	34.F.106
ALGEMEEN	34.F.107
BASISSET AUTOMATISCHE HEFSCHUIFDEUR	34.F.108
BASISSET AUTOMATISCHE HEFSCHUIFDEUR	34.F.109
U-WAARDEN	34.F.110
U-WAARDEN	34.F.111
BASISSET AUTOMATISCHE HEFSCHUIFDEUR	34.F.112

Toebehoren

TOEBEHORENLIJST	34.G.a01
TOEBEHORENLIJST	34.G.a02
OVERZICHT	34.G.001
OVERZICHT	34.G.002
OVERZICHT	34.G.003
OVERZICHT	34.G.004
OVERZICHT	34.G.005
OVERZICHT	34.G.006
PERSHOEKEN	34.G.007
SCHROEFHOEKEN	34.G.008
VULHOEKEN	34.G.009
STEUNHOEKEN	34.G.010
EINDSTUKKEN	34.G.011
T-VERBINDING	34.G.012
T-VERBINDING	34.G.013
T-VERBINDER	34.G.014
AFDICHTINGSSTUK T-VERBINDER	34.G.015
T-VERBINDER VERSTELBAAR	34.G.016
T-VERBINDER VERSTELBAAR	34.G.017
T-VERBINDER VERSTELBAAR	34.G.018
DEURKRUKKEN	34.G.019
DEURKRUKKEN	34.G.020
DEURKRUKKEN	34.G.021
DEURKRUKKEN	34.G.022
SET STIFT + SCHROEVEN	34.G.023
INBRAAKWEREND	34.G.024
INBRAAKWEREND	34.G.025

SLOTEN	34.G.026
HAAKSLOTEN	34.G.027
SLOTPADEN	34.G.028
CILINDER	34.G.029
SLOTPADEN	34.G.030
BASISSET HEFSCHUIFDEUR	34.G.031
BASISSET HEFSCHUIFDEUR	34.G.032
SLOTEN	34.G.033
GLASSTEUN	34.G.034
WIEL	34.G.035
BUFFER	34.G.036
ALGEMENE TOEBEHOREN	34.G.037
ALGEMENE TOEBEHOREN	34.G.038
ALGEMENE TOEBEHOREN	34.G.039
ALGEMENE TOEBEHOREN	34.G.040
BEGLAZINGSDICHTINGEN	34.G.041
BEGLAZINGSDICHTINGEN	34.G.042
BEGLAZINGSDICHTINGEN	34.G.043
DICHTINGEN	34.G.044
DICHTINGEN	34.G.045
AFDICHTINGEN	34.G.046
AFDICHTINGEN	34.G.047
BORSTELDICHTINGEN	34.G.048
VERANKERINGEN	34.G.049
DIVERSEN	34.G.050
DIVERSEN	34.G.051
DIVERSEN	34.G.052
DIVERSEN	34.G.053
DIVERSEN	34.G.054
DIVERSEN	34.G.055
DIVERSEN	34.G.056
DIVERSEN	34.G.057
BEVESTIGINGSMIDDELEN	34.G.058
BEVESTIGINGSMIDDELEN	34.G.059
BEVESTIGINGSMIDDELEN	34.G.060
BEVESTIGINGSMIDDELEN	34.G.061
BEVESTIGINGSMIDDELEN	34.G.062
BEVESTIGINGSMIDDELEN	34.G.063
BEVESTIGINGSMIDDELEN	34.G.064
BEVESTIGINGSMIDDELEN	34.G.065
BEVESTIGINGSMIDDELEN	34.G.066
BEVESTIGINGSMIDDELEN	34.G.067
BEVESTIGINGSMIDDELEN	34.G.068
BEVESTIGINGSMIDDELEN	34.G.069
BEVESTIGINGSMIDDELEN	34.G.070
BASISSET AUTOMATISCHE HEFSCHUIFDEUR	34.G.071
BASISSET AUTOMATISCHE HEFSCHUIFDEUR	34.G.072
BOORMALLEN EN MATRIJZEN	34.G.073
BOORMALLEN EN MATRIJZEN	34.G.074
BOORMALLEN EN MATRIJZEN	34.G.075
BOORMALLEN EN MATRIJZEN	34.G.076
BOORMALLEN EN MATRIJZEN	34.G.077
BOORMAL	34.G.078
BOORMALLEN EN MATRIJZEN	34.G.079
BOORMALLEN EN MATRIJZEN	34.G.080
BOORMALLEN EN MATRIJZEN	34.G.081
BOORMALLEN EN MATRIJZEN	34.G.082
MACHINES EN TOEBEHOREN	34.G.083
MACHINES EN TOEBEHOREN	34.G.084



TABLE DES MATIERES	34.001
TABLE DES MATIERES	34.002
TABLE DES MATIERES	34.003
TABLE DES MATIERES	34.004
TABLE DES MATIERES	34.005
TABLE DES MATIERES	34.006
TABLE DES MATIERES	34.007
TABLE DES MATIERES	34.008
TABLE DES MATIERES	34.009
TABLE DES MATIERES	34.010
TABLE DES MATIERES	34.011
TABLE DES MATIERES	34.012
TABLE DES MATIERES	34.013
TABLE DES MATIERES	34.014
TABLE DES MATIERES	34.015
TABLE DES MATIERES	34.016
TABLE DES MATIERES	34.017
TABLE DES MATIERES	34.018
TABLE DES MATIERES	34.019
TABLE DES MATIERES	34.020
TABLE DES MATIERES	34.021
TABLE DES MATIERES	34.022

Généralités

Liste des symboles	34.A.001
Liste des symboles	34.A.002
Liste des symboles	34.A.003
Liste des symboles	34.A.004
Liste des symboles	34.A.005
Liste des symboles	34.A.006
Liste des symboles	34.A.007

Généralités séries

Prescriptions de mise en oeuvre	34.B.001
Prescriptions de mise en oeuvre	34.B.002
Prescriptions de mise en oeuvre	34.B.003
Prescriptions de mise en oeuvre	34.B.004

Profils

Liste des profils	34.C.p01
Liste des profils	34.C.p02
Aperçu des profils	34.C.001
Aperçu des profils	34.C.002
Aperçu des profils	34.C.003
Aperçu des profils	34.C.004
Aperçu des profils	34.C.005
Aperçu des profils	34.C.006
Parcloses	34.C.007
Guide à volet	34.C.008
Profils de raccordement	34.C.009
Dormants	34.C.010
Dormants	34.C.011
Dormant	34.C.012
Dormant protection anti-vol	34.C.013

DORMANT	34.C.014
DORMANTS MONORAIL	34.C.015
DORMANTS MONORAIL	34.C.016
PROFIL DE RECouvreMENT DORMANT MONORAIL	34.C.017
DORMANT 3-RAIL	34.C.018
DORMANT 3-RAIL	34.C.019
DORMANT 3-RAIL	34.C.020
Ouvrants	34.C.021
Ouvrants protection anti-vol	34.C.022
PROFILS DE RACCORDEMENT OUVRANT	34.C.023
PROFILS DE RACCORDEMENT OUVRANT	34.C.024
PROFILS DE RENFORCEMENT OUVRANT	34.C.025
TRAVERSES	34.C.026
TRAVERSES	34.C.027
TRAVERSES	34.C.028
TRAVERSES	34.C.029
CHICANE	34.C.030
PARCLOSES	34.C.031
PARCLOSES	34.C.032
PROTECTION ANTI-VOL	34.C.033
PROTECTION ANTI-VOL	34.C.034
TABLEAU DE VITRAGE	34.C.035
TABLEAU DE VITRAGE	34.C.036
GUIDES A VOLET	34.C.037
GUIDES A VOLET	34.C.038
PROFIL DE DILATATION	34.C.039
PROFIL DE RACCORDEMENT	34.C.040
PROFILS DE RACCORDEMENT	34.C.041
PROFILS DE RACCORDEMENT	34.C.042
PROFILS DE RACCORDEMENT	34.C.043
PROFILS DE RACCORDEMENT	34.C.044
CAPUCHON POUR MOTEUR	34.C.045
2-RAIL XQ FLAT BOTTOM	34.C.046
2-RAIL XQ FLAT BOTTOM	

Sections des noeuds

2-RAIL	34.D.001
2-RAIL	34.D.002
2-RAIL	34.D.003
2-RAIL	34.D.004
2-RAIL	34.D.005
2-RAIL	34.D.006
2-RAIL	34.D.007
2-RAIL	34.D.008
2-RAIL	34.D.009
2-RAIL	34.D.010
2-RAIL	34.D.011
2-RAIL	34.D.012
MONORAIL	34.D.013
MONORAIL	34.D.014
MONORAIL	34.D.015
MONORAIL	34.D.016
MONORAIL	34.D.017
MONORAIL	34.D.018
3-RAIL	34.D.019
3-RAIL	34.D.020
3-RAIL	34.D.021



3-RAIL	34.D.022	2-RAIL OXXO	34.E.025
3-RAIL	34.D.023	2-RAIL OXXO	34.E.026
2-RAIL	34.D.024	2-RAIL OXXO	34.E.027
2-RAIL	34.D.025	2-RAIL OXXO	34.E.028
2-RAIL	34.D.026	2-RAIL OXXO	34.E.029
2-RAIL	34.D.027	2-RAIL OXQ	34.E.030
2-RAIL	34.D.028	2-RAIL OXQ	34.E.031
2-RAIL	34.D.029	2-RAIL OXQ	34.E.032
2-RAIL	34.D.030	2-RAIL OXQ	34.E.033
2-RAIL	34.D.031	MONORAIL XQ	34.E.034
2-RAIL	34.D.032	MONORAIL XQ	34.E.035
2-RAIL	34.D.033	MONORAIL XQ	34.E.036
2-RAIL	34.D.034	MONORAIL XQ	34.E.037
2-RAIL	34.D.035	MONORAIL XQX	34.E.038
2-RAIL	34.D.036	MONORAIL XQX	34.E.039
MONORAIL	34.D.037	MONORAIL XQX	34.E.040
MONORAIL	34.D.038	MONORAIL XQX	34.E.041
MONORAIL	34.D.039	MONORAIL QXXQ	34.E.042
MONORAIL	34.D.040	MONORAIL QXXQ	34.E.043
MONORAIL	34.D.041	MONORAIL QXXQ	34.E.044
MONORAIL	34.D.042	MONORAIL QXXQ	34.E.045
MONORAIL	34.D.043	MONORAIL QXXQ	34.E.046
MONORAIL	34.D.044	MONORAIL QXXQ	34.E.047
3-RAIL	34.D.045	3-RAIL XXX	34.E.048
3-RAIL	34.D.046	3-RAIL XXX	34.E.049
3-RAIL	34.D.047	3-RAIL XXX	34.E.050
3-RAIL	34.D.048	3-RAIL XXX	34.E.051
3-RAIL	34.D.049	3-RAIL XXX	34.E.052
2-RAIL QXQ	34.D.050	3-RAIL XXX	34.E.053
2-RAIL FLAT BOTTOM	34.D.051	2-RAIL XQ	34.E.054
2-RAIL FLAT BOTTOM		2-RAIL XO	34.E.055
2-RAIL FLAT BOTTOM	34.D.052	2-RAIL XQ FLAT BOTTOM	34.E.056
		2-RAIL XQ FLAT BOTTOM	34.E.057
		2-RAIL XQ	34.E.058
		2-RAIL XO	34.E.059
		2-RAIL XQ FLAT BOTTOM	34.E.060
		2-RAIL XQ FLAT BOTTOM	34.E.061
		2-RAIL XX	34.E.062
		2-RAIL XX	34.E.063
		2-RAIL XX	34.E.064
		2-RAIL XX	34.E.065
		2-RAIL XX	34.E.066
		2-RAIL XX	34.E.067
		2-RAIL XQX	34.E.068
		2-RAIL XQX	34.E.069
		2-RAIL XQX	34.E.070
		2-RAIL XQX	34.E.071
		2-RAIL XQX	34.E.072
		2-RAIL XQX	34.E.073
		2-RAIL QXXQ	34.E.074
		2-RAIL QXXQ	34.E.075
		2-RAIL QXXQ	34.E.076
		2-RAIL QXXQ	34.E.077
		2-RAIL QXXQ	34.E.078
		2-RAIL QXXQ	34.E.079
		2-RAIL XXXX	34.E.080
		2-RAIL XXXX	34.E.081
		2-RAIL XXXX	34.E.082
		2-RAIL XXXX	34.E.083
		2-RAIL XXXX	

Coupes et débits

2-RAIL XQ	34.E.001
2-RAIL XQ	34.E.002
2-RAIL XQ	34.E.003
2-RAIL XQ	34.E.004
2-RAIL XQ	34.E.005
2-RAIL XQ VARIANTE HI	34.E.006
2-RAIL XQ VARIANTE HI	34.E.007
2-RAIL XQ VARIANTE HI	34.E.008
2-RAIL XQ VARIANTE HI	34.E.009
2-RAIL XO	34.E.010
2-RAIL XO	34.E.011
2-RAIL XO	34.E.012
2-RAIL XO	34.E.013
2-RAIL XQX	34.E.014
2-RAIL XQX	34.E.015
2-RAIL XQX	34.E.016
2-RAIL XQX	34.E.017
2-RAIL QXXQ	34.E.018
2-RAIL QXXQ	34.E.019
2-RAIL QXXQ	34.E.020
2-RAIL QXXQ	34.E.021
2-RAIL QXXQ	34.E.022
2-RAIL QXXQ	34.E.023
2-RAIL OXXO	34.E.024



2-RAIL XXXX	34.E.084	RACCORDEMENT-T MONORAIL	34.F.024
2-RAIL XXXX	34.E.085	RACCORDEMENT-T MONORAIL	34.F.025
2-RAIL QXQ	34.E.086	MONTAGE FERMETURE AVEC BROSSE	34.F.026
2-RAIL QXQ	34.E.087	MONTAGE FERMETURE AVEC BROSSE	34.F.027
2-RAIL QXQ	34.E.088	MONTAGE VANTAIL COULISSANT	34.F.028
2-RAIL QXQ	34.E.089	MONTAGE VANTAIL COULISSANT	34.F.029
MONORAIL XQ	34.E.090	ENCASTREMENT SERRURE DE SECURITE	34.F.030
MONORAIL XQ	34.E.091	ENCASTREMENT SERRURE DE SECURITE 4-RAIL	34.F.031
MONORAIL XQ	34.E.092	ENCASTREMENT FERMETURE A 5 POINTS	34.F.032
MONORAIL XQ	34.E.093	ENCASTREMENT FERMETURE A 5 POINTS	34.F.033
MONORAIL QXX	34.E.094	ENCASTREMENT PIECES DE BASE SOULEV. COULISSANT	34.F.034
MONORAIL QXX	34.E.095	ENCASTREMENT PIECES DE BASE SOULEV. COULISSANT	34.F.035
MONORAIL QXX	34.E.096	ENCASTREMENT PIECES DE BASE SOULEV. COULISS. 4-RAIL	34.F.036
MONORAIL QXX	34.E.097	ENCASTREMENT PIECES DE BASE SOULEV. COULISS. 4-RAIL	34.F.037
MONORAIL QXX	34.E.098	ENCASTREMENT PIECES DE BASE SOULEV. COULISS. 4-RAIL MIN. 300KG MAX. 4000	34.F.038
MONORAIL QXX	34.E.099	ENCASTREMENT PIECES DE BASE SOULEV. COULISS. 4-RAIL MIN. 300KG MAX. 4000	34.F.039
MONORAIL QXXQ	34.E.100	ENCASTREMENT PIECES DE BASE SOULEV. COULISS. 4-RAIL	34.F.040
MONORAIL QXXQ	34.E.101	ENCASTREMENT PIECES DE BASE SOULEV. COULISS. 4-RAIL	34.F.041
MONORAIL QXXQ	34.E.102	ASSEMBLAGE BEQUILLE	34.F.042
MONORAIL QXXQ	34.E.103	ASSEMBLAGE BEQUILLE	34.F.043
MONORAIL QXXQ	34.E.104	ASSEMBLAGE BEQUILLE KABA	34.F.044
MONORAIL QXXQ	34.E.105	ASSEMBLAGE BEQUILLE KABA	34.F.045
3-RAIL XXX	34.E.106	PROTECTION ANTI-VOL	34.F.046
3-RAIL XXX	34.E.107	PROTECTION ANTI-VOL	34.F.047
3-RAIL XXX	34.E.108	JONCTION AVEC D'AUTRES SYSTEMES	34.F.048
3-RAIL XXX	34.E.109	JONCTION AVEC D'AUTRES SYSTEMES	34.F.049
3-RAIL XXX	34.E.110	USINER LIAISON CENTRALE 4 VANTAUX	34.F.050
3-RAIL XXX	34.E.111	USINER LIAISON CENTRALE 4 VANTAUX	34.F.051
SOULEV. COULISSANT AUTOMATIQUE	34.E.112	USINER LIAISON CENTRALE 4 VANTAUX	34.F.052
SOULEV. COULISSANT AUTOMATIQUE	34.E.113	USINER LIAISON CENTRALE 4 VANTAUX	34.F.053
SOULEV. COULISSANT AUTOMATIQUE	34.E.114	2-RAIL RAINURE PROFILE DE SEUIL	34.F.054
SOULEV. COULISSANT AUTOMATIQUE	34.E.115	2-RAIL RAINURE PROFILE DE SEUIL	34.F.055
SOULEV. COULISSANT AUTOMATIQUE	34.E.116	USINER LIAISON CENTRALE 2-RAIL QXQ	34.F.056
		USINER LIAISON CENTRALE 2-RAIL QXQ	34.F.057
		BUTEE	34.F.058
		BUTEE	34.F.059
		DRAINAGE OUVRANT	34.F.060
		DECOMPRESSION OUVRANTS	34.F.061
		DRAINAGE TYPE XQ XO QXQ	34.F.062
		DRAINAGE TYPE XQ XO QXQ	34.F.063
		DRAINAGE TYPE QXX QXXQ OXXO	34.F.064
		DRAINAGE TYPE QXX QXXQ OXXO	34.F.065
		DRAINAGE TYPE XQ XO QXQ	34.F.066
		DRAINAGE TYPE XQ XO QXQ	34.F.067
		DRAINAGE TYPE QXX QXXQ OXXO	34.F.068
		DRAINAGE TYPE QXX QXXQ OXXO	34.F.069
		DRAINAGE MONORAIL TYPE XQ	34.F.070
		DRAINAGE MONORAIL TYPE XQ	34.F.071
		DRAINAGE MONORAIL TYPE QXX	34.F.072
		DRAINAGE MONORAIL TYPE QXX	34.F.073
		DRAINAGE MONORAIL TYPE QXXQ	34.F.074
		DRAINAGE MONORAIL TYPE QXXQ	34.F.075
		DRAINAGE MONORAIL TYPE XQ	34.F.076
		DRAINAGE MONORAIL TYPE XQ	34.F.077
		DRAINAGE MONORAIL TYPE QXX	34.F.078
		DRAINAGE MONORAIL TYPE QXX	34.F.079
		DRAINAGE MONORAIL TYPE QXXQ	34.F.080
		DRAINAGE MONORAIL TYPE QXXQ	34.F.081
		DRAINAGE TYPE XXX XXQ	34.F.082
		DRAINAGE TYPE XXX XXQ	34.F.083

Fabrication et montage

EQUERRE	34.F.001
EQUERRE	34.F.002
EQUERRE	34.F.003
ASSEMBLAGE EQUERRE A BLOCAGE	34.F.004
ASSEMBLAGE EQUERRE A BLOCAGE	34.F.005
ASSEMBLAGE ANGULAIRE MONORAIL	34.F.006
ASSEMBLAGE ANGULAIRE MONORAIL	34.F.007
ASSEMBLAGE EQUERRE A BLOCAGE MONORAIL	34.F.008
ASSEMBLAGE EQUERRE A BLOCAGE MONORAIL	34.F.009
ASSEMBLAGE DORMANT	34.F.010
ASSEMBLAGE DORMANT	34.F.011
ASSEMBLAGE DORMANT MONORAIL	34.F.012
ASSEMBLAGE DORMANT MONORAIL	34.F.013
ASSEMBLAGE DORMANT 3-RAIL	34.F.014
ASSEMBLAGE DORMANT 3-RAIL	34.F.015
ASSEMBLAGE ANGULAIRE OUVRANT	34.F.016
ASSEMBLAGE ANGULAIRE OUVRANT	34.F.017
RACCORDEMENTS-T	34.F.018
RACCORDEMENTS-T	34.F.019
JONCTION-T AVEC VIS	34.F.020
JONCTION-T AVEC CHEVILLE	34.F.021
RACCORDEMENT-T MONORAIL	34.F.022
RACCORDEMENT-T MONORAIL	34.F.023



DRAINAGE TYPE XXX XXQ	34.F.084
DRAINAGE TYPE XXX XXQ	34.F.085
PIECE DE RACCORDEMENT	34.F.086
PIECE DE RACCORDEMENT	34.F.087
SUPPORTS CALE DE VITRAGE	34.F.088
ASSEMBLAGE PIECE DE BLOCAGE	34.F.089
ASSEMBLAGE 062.7927.04 / 062.8045.04	34.F.090
ASSEMBLAGE 062.7927.04 / 062.8045.04	34.F.091
DIMENSIONS MAX. ADMISSIBLE OUVRANTS	34.F.092
DIMENSIONS MAX. ADMISSIBLE OUVRANTS	34.F.093
DIMENSIONS MAX. ADMISSIBLE OUVRANTS	34.F.094
DIMENSIONS MAX. ADMISSIBLE OUVRANTS	34.F.095
DIMENSIONS MAX. ADMISSIBLE OUVRANTS	34.F.096
DIMENSIONS MAX. ADMISSIBLE OUVRANTS	34.F.097
DIMENSIONS MAX. ADMISSIBLE OUVRANTS	34.F.098
DIMENSIONS MAX. ADMISSIBLE OUVRANTS	34.F.099
DIMENSIONS MAX. ADMISSIBLE OUVRANTS	34.F.100
DIMENSIONS MAX. ADMISSIBLE OUVRANTS	34.F.101
DIMENSIONS MAX. ADMISSIBLE OUVRANTS	34.F.102
DIMENSIONS MAX. ADMISSIBLE OUVRANTS	34.F.103
SET DE BASE SOULEV. COULISSANT AUTOMATIQUE	34.F.104
SET DE BASE SOULEV. COULISSANT AUTOMATIQUE	34.F.105
GENERAL	34.F.106
GENERAL	34.F.107
SET DE BASE SOULEV. COULISSANT AUTOMATIQUE	34.F.108
SET DE BASE SOULEV. COULISSANT AUTOMATIQUE	34.F.109
VALEURS-U	34.F.110
VALEURS-U	34.F.111
SET DE BASE SOULEV. COULISSANT AUTOMATIQUE	34.F.112

Accessoires

LISTE DES ACCESSOIRES	34.G.a01
LISTE DES ACCESSOIRES	34.G.a02
APERCU	34.G.001
APERCU	34.G.002
APERCU	34.G.003
APERCU	34.G.004
APERCU	34.G.005
APERCU	34.G.006
EQUERRES A SERTIR	34.G.007
EQUERRES A VISSER	34.G.008
EQUERRES DE REMPLISSAGE	34.G.009
CALES DE FEUILLURE	34.G.010
PIECES FINALES	34.G.011
RACCORDEMENT-T	34.G.012
RACCORDEMENT-T	34.G.013
JONCTION-T	34.G.014
PIECE D'ETANCHEITE JONCTION-T	34.G.015
JONCTION-T REGLABLE	34.G.016
JONCTION-T REGLABLE	34.G.017
JONCTION-T REGLABLE	34.G.018
BEQUILLES	34.G.019
BEQUILLES	34.G.020
BEQUILLES	34.G.021
BEQUILLES	34.G.022
SET TIGE + VIS	34.G.023
PROTECTION ANTI-VOL	34.G.024
PROTECTION ANTI-VOL	34.G.025

SERRURES	34.G.026
SERRURES	34.G.027
GACHES	34.G.028
CYLINDRE	34.G.029
GACHES	34.G.030
SET DE BASE SOULEV. COULISSANT	34.G.031
SET DE BASE SOULEV. COULISSANT	34.G.032
SERRURES	34.G.033
SUPPORT CALE DE VITRAGE	34.G.034
ROULETTE	34.G.035
BUTEE	34.G.036
ACCESSOIRES GENERAUX	34.G.037
ACCESSOIRES GENERAUX	34.G.038
ACCESSOIRES GENERAUX	34.G.039
ACCESSOIRES GENERAUX	34.G.040
JOINTS DE VITRAGE	34.G.041
JOINTS DE VITRAGE	34.G.042
JOINTS DE VITRAGE	34.G.043
JOINTS	34.G.044
JOINTS	34.G.045
FERMETURES	34.G.046
FERMETURES	34.G.047
JOINTS-BROSSE	34.G.048
ANCRAGES	34.G.049
DIVERS	34.G.050
DIVERS	34.G.051
DIVERS	34.G.052
DIVERS	34.G.053
DIVERS	34.G.054
DIVERS	34.G.055
DIVERS	34.G.056
DIVERS	34.G.057
MOYENS DE FIXATION	34.G.058
MOYENS DE FIXATION	34.G.059
MOYENS DE FIXATION	34.G.060
MOYENS DE FIXATION	34.G.061
MOYENS DE FIXATION	34.G.062
MOYENS DE FIXATION	34.G.063
MOYENS DE FIXATION	34.G.064
MOYENS DE FIXATION	34.G.065
MOYENS DE FIXATION	34.G.066
MOYENS DE FIXATION	34.G.067
MOYENS DE FIXATION	34.G.068
MOYENS DE FIXATION	34.G.069
MOYENS DE FIXATION	34.G.070
SET DE BASE SOULEV. COULISSANT AUTOMATIQUE	34.G.071
SET DE BASE SOULEV. COULISSANT AUTOMATIQUE	34.G.072
CALIBRES DE PERCAGE ET MATRICES	34.G.073
CALIBRES DE PERCAGE ET MATRICES	34.G.074
CALIBRES DE PERCAGE ET MATRICES	34.G.075
CALIBRES DE PERCAGE ET MATRICES	34.G.076
CALIBRES DE PERCAGE ET MATRICES	34.G.077
CALIBRE DE PERCAGE	34.G.078
CALIBRES DE PERCAGE ET MATRICES	34.G.079
CALIBRES DE PERCAGE ET MATRICES	34.G.080
CALIBRES DE PERCAGE ET MATRICES	34.G.081
CALIBRES DE PERCAGE ET MATRICES	34.G.082
CALIBRES DE PERCAGE ET MATRICES	34.G.082
MACHINES ET ACCESSOIRES	34.G.083
MACHINES ET ACCESSOIRES	34.G.084



TABLE OF CONTENTS	34.001
TABLE OF CONTENTS	34.002
TABLE OF CONTENTS	34.003
TABLE OF CONTENTS	34.004
TABLE OF CONTENTS	34.005
TABLE OF CONTENTS	34.006
TABLE OF CONTENTS	34.007
TABLE OF CONTENTS	34.008
TABLE OF CONTENTS	34.009
TABLE OF CONTENTS	34.010
TABLE OF CONTENTS	34.011
TABLE OF CONTENTS	34.012
TABLE OF CONTENTS	34.013
TABLE OF CONTENTS	34.014
TABLE OF CONTENTS	34.015
TABLE OF CONTENTS	34.016
TABLE OF CONTENTS	34.017
TABLE OF CONTENTS	34.018
TABLE OF CONTENTS	34.019
TABLE OF CONTENTS	34.020
TABLE OF CONTENTS	34.021
TABLE OF CONTENTS	34.022

General Information

LIST OF SYMBOLS	34.A.001
LIST OF SYMBOLS	34.A.002
LIST OF SYMBOLS	34.A.003
LIST OF SYMBOLS	34.A.004
LIST OF SYMBOLS	34.A.005
LIST OF SYMBOLS	34.A.006
LIST OF SYMBOLS	34.A.007

General Information System

PROCESSING DATA	34.B.001
PROCESSING DATA	34.B.002
PROCESSING DATA	34.B.003
PROCESSING DATA	34.B.004

Profiles

LIST OF PROFILES	34.C.p01
LIST OF PROFILES	34.C.p02
PROFILE OVERVIEW	34.C.001
PROFILE OVERVIEW	34.C.002
PROFILE OVERVIEW	34.C.003
PROFILE OVERVIEW	34.C.004
PROFILE OVERVIEW	34.C.005
PROFILE OVERVIEW	34.C.006
GLAZING BEADS	34.C.007
SHUTTER GUIDE	34.C.008
ADDITIONAL PROFILES	34.C.009
OUTER FRAMES	34.C.010
OUTER FRAMES	34.C.011
OUTER FRAME	34.C.012
OUTER FRAME BURGLAR PROTECTION	34.C.013

OUTER FRAME	34.C.014
OUTER FRAMES MONORAIL	34.C.015
OUTER FRAMES MONORAIL	34.C.016
COVERING PROFILE OUTER FRAME MONORAIL	34.C.017
OUTER FRAME 3-RAIL	34.C.018
OUTER FRAME 3-RAIL	34.C.019
OUTER FRAME 3-RAIL	34.C.020
VENTS	34.C.021
VENTS BURGLAR PROTECTION	34.C.022
ADDITIONAL PROFILES VENT	34.C.023
ADDITIONAL PROFILES VENT	34.C.024
REINFORCEMENT PROFILES VENT	34.C.025
TRANSOM-MULLIONS	34.C.026
TRANSOM-MULLIONS	34.C.027
TRANSOM-MULLIONS	34.C.028
TRANSOM-MULLIONS	34.C.029
MEETING SECTION	34.C.030
GLAZING BEADS	34.C.031
GLAZING BEADS	34.C.032
BURGLAR PROTECTION	34.C.033
BURGLAR PROTECTION	34.C.034
GLAZING TABLE	34.C.035
GLAZING TABLE	34.C.036
SHUTTER GUIDES	34.C.037
SHUTTER GUIDES	34.C.038
EXPANSION PROFILE	34.C.039
CONNECTION PROFILE	34.C.040
ADDITIONAL PROFILES	34.C.041
ADDITIONAL PROFILES	34.C.042
ADDITIONAL PROFILES	34.C.043
ADDITIONAL PROFILES	34.C.044
COVER MOTOR	34.C.045
2-RAIL XQ FLAT BOTTOM	34.C.046
2-RAIL XQ FLAT BOTTOM	

Section drawings







2-RAIL	34.D.001
2-RAIL	34.D.002
2-RAIL	34.D.003
2-RAIL	34.D.004
2-RAIL	34.D.005
2-RAIL	34.D.006
2-RAIL	34.D.007
2-RAIL	34.D.008
2-RAIL	34.D.009
2-RAIL	34.D.010
2-RAIL	34.D.011
2-RAIL	34.D.012
MONORAIL	34.D.013
MONORAIL	34.D.014
MONORAIL	34.D.015
MONORAIL	34.D.016
MONORAIL	34.D.017
MONORAIL	34.D.018
3-RAIL	34.D.019
3-RAIL	34.D.020
3-RAIL	34.D.021



3-RAIL	34.D.022	2-RAIL OXXO	34.E.025
3-RAIL	34.D.023	2-RAIL OXXO	34.E.026
2-RAIL	34.D.024	2-RAIL OXXO	34.E.027
2-RAIL	34.D.025	2-RAIL OXXO	34.E.028
2-RAIL	34.D.026	2-RAIL OXXO	34.E.029
2-RAIL	34.D.027	2-RAIL OXQ	34.E.030
2-RAIL	34.D.028	2-RAIL OXQ	34.E.031
2-RAIL	34.D.029	2-RAIL OXQ	34.E.032
2-RAIL	34.D.030	2-RAIL OXQ	34.E.033
2-RAIL	34.D.031	MONORAIL XQ	34.E.034
2-RAIL	34.D.032	MONORAIL XQ	34.E.035
2-RAIL	34.D.033	MONORAIL XQ	34.E.036
2-RAIL	34.D.034	MONORAIL XQ	34.E.037
2-RAIL	34.D.035	MONORAIL QXX	34.E.038
2-RAIL	34.D.036	MONORAIL QXX	34.E.039
MONORAIL	34.D.037	MONORAIL QXX	34.E.040
MONORAIL	34.D.038	MONORAIL QXX	34.E.041
MONORAIL	34.D.039	MONORAIL QXXQ	34.E.042
MONORAIL	34.D.040	MONORAIL QXXQ	34.E.043
MONORAIL	34.D.041	MONORAIL QXXQ	34.E.044
MONORAIL	34.D.042	MONORAIL QXXQ	34.E.045
MONORAIL	34.D.043	MONORAIL QXXQ	34.E.046
MONORAIL	34.D.044	MONORAIL QXXQ	34.E.047
3-RAIL	34.D.045	3-RAIL XXX	34.E.048
3-RAIL	34.D.046	3-RAIL XXX	34.E.049
3-RAIL	34.D.047	3-RAIL XXX	34.E.050
3-RAIL	34.D.048	3-RAIL XXX	34.E.051
3-RAIL	34.D.049	3-RAIL XXX	34.E.052
2-RAIL QXQ	34.D.050	3-RAIL XXX	34.E.053
2-RAIL FLAT BOTTOM	34.D.051	2-RAIL XQ	34.E.054
2-RAIL FLAT BOTTOM		2-RAIL XO	34.E.055
2-RAIL FLAT BOTTOM	34.D.052	2-RAIL XQ FLAT BOTTOM	34.E.056
		2-RAIL XQ FLAT BOTTOM	34.E.057
		2-RAIL XQ	34.E.058
		2-RAIL XO	34.E.059
		2-RAIL XQ FLAT BOTTOM	34.E.060
		2-RAIL XQ FLAT BOTTOM	34.E.061
		2-RAIL XX	34.E.062
		2-RAIL XX	34.E.063
		2-RAIL XX	34.E.064
		2-RAIL XX	34.E.065
		2-RAIL XX	34.E.066
		2-RAIL XX	34.E.067
		2-RAIL QXQ	34.E.068
		2-RAIL QXQ	34.E.069
		2-RAIL QXQ	34.E.070
		2-RAIL QXQ	34.E.071
		2-RAIL QXQ	34.E.072
		2-RAIL QXQ	34.E.073
		2-RAIL QXXQ	34.E.074
		2-RAIL QXXQ	34.E.075
		2-RAIL QXXQ	34.E.076
		2-RAIL QXXQ	34.E.077
		2-RAIL QXXQ	34.E.078
		2-RAIL QXXQ	34.E.079
		2-RAIL XXXX	34.E.080
		2-RAIL XXXX	34.E.081
		2-RAIL XXXX	34.E.082
		2-RAIL XXXX	34.E.083
		2-RAIL XXXX	34.E.084

Work drawings

2-RAIL XQ	34.E.001
2-RAIL XQ	34.E.002
2-RAIL XQ	34.E.003
2-RAIL XQ	34.E.004
2-RAIL XQ	34.E.005
2-RAIL XQ VARIANT HI	34.E.006
2-RAIL XQ VARIANT HI	34.E.007
2-RAIL XQ VARIANT HI	34.E.008
2-RAIL XQ VARIANT HI	34.E.009
2-RAIL XO	34.E.010
2-RAIL XO	34.E.011
2-RAIL XO	34.E.012
2-RAIL XO	34.E.013
2-RAIL QXQ	34.E.014
2-RAIL QXQ	34.E.015
2-RAIL QXQ	34.E.016
2-RAIL QXQ	34.E.017
2-RAIL QXXQ	34.E.018
2-RAIL QXXQ	34.E.019
2-RAIL QXXQ	34.E.020
2-RAIL QXXQ	34.E.021
2-RAIL QXXQ	34.E.022
2-RAIL QXXQ	34.E.023
2-RAIL OXXO	34.E.024

					
2-RAIL XXXX		34.E.084	T-CONNECTION MONORAIL		34.F.024
2-RAIL XXXX		34.E.085	T-CONNECTION MONORAIL		34.F.025
2-RAIL QXQ		34.E.086	ASSEMBLY CLOSER WITH BRUSH		34.F.026
2-RAIL QXQ		34.E.087	ASSEMBLY CLOSER WITH BRUSH		34.F.027
2-RAIL QXQ		34.E.088	ASSEMBLY SLIDING VENT		34.F.028
2-RAIL QXQ		34.E.089	ASSEMBLY SLIDING VENT		34.F.029
MONORAIL XQ		34.E.090	EMBEDDING SAFETY LOCK		34.F.030
MONORAIL XQ		34.E.091	EMBEDDING SECURITY LOCK 4-RAIL		34.F.031
MONORAIL XQ		34.E.092	EMBEDDING 5 POINT LOCK		34.F.032
MONORAIL XQ		34.E.093	EMBEDDING 5 POINT LOCK		34.F.033
MONORAIL QXQ		34.E.094	EMBEDDING BASIC SET LIFT AND SLIDING DOOR		34.F.034
MONORAIL QXQ		34.E.095	EMBEDDING BASIC SET LIFT AND SLIDING DOOR		34.F.035
MONORAIL QXQ		34.E.096	EMBEDDING BASIC SET LIFT AND SLIDING DOOR 4-RAIL		34.F.036
MONORAIL QXQ		34.E.097	EMBEDDING BASIC SET LIFT AND SLIDING DOOR 4-RAIL		34.F.037
MONORAIL QXQ		34.E.098	EMBEDDING BASIC SET LIFT AND SLIDING DOOR 4-RAIL MIN. 300KG MAX. 4000		34.F.038
MONORAIL QXQ		34.E.099	EMBEDDING BASIC SET LIFT AND SLIDING DOOR 4-RAIL MIN. 300KG MAX. 4000		34.F.039
MONORAIL QXXQ		34.E.100	EMBEDDING BASIC SET LIFT AND SLIDING DOOR 4-RAIL		34.F.040
MONORAIL QXXQ		34.E.101	EMBEDDING BASIC SET LIFT AND SLIDING DOOR 4-RAIL		34.F.041
MONORAIL QXXQ		34.E.102	ASSEMBLY DOOR HANDLE		34.F.042
MONORAIL QXXQ		34.E.103	ASSEMBLY DOOR HANDLE		34.F.043
MONORAIL QXXQ		34.E.104	ASSEMBLY DOOR HANDLE KABA		34.F.044
MONORAIL QXXQ		34.E.105	ASSEMBLY DOOR HANDLE KABA		34.F.045
3-RAIL XXX		34.E.106	BURGLAR PROTECTION		34.F.046
3-RAIL XXX		34.E.107	BURGLAR PROTECTION		34.F.047
3-RAIL XXX		34.E.108	CONNECTION WITH OTHER SYSTEMS		34.F.048
3-RAIL XXX		34.E.109	CONNECTION WITH OTHER SYSTEMS		34.F.049
3-RAIL XXX		34.E.110	PROCESSING MEETING STILE 4 DOOR		34.F.050
3-RAIL XXX		34.E.111	PROCESSING MEETING STILE 4 DOOR		34.F.051
AUTOMATIC LIFT AND SLIDING DOOR		34.E.112	PROCESSING MEETING STILE 4 DOOR		34.F.052
AUTOMATIC LIFT AND SLIDING DOOR		34.E.113	PROCESSING MEETING STILE 4 DOOR		34.F.053
AUTOMATIC LIFT AND SLIDING DOOR		34.E.114	2-RAIL RECESS BOTTOM PROFILE		34.F.054
AUTOMATIC LIFT AND SLIDING DOOR		34.E.115	2-RAIL RECESS BOTTOM PROFILE		34.F.055
AUTOMATIC LIFT AND SLIDING DOOR		34.E.116	PROCESSING MEETING STILE 2-RAIL QXQ		34.F.056
			PROCESSING MEETING STILE 2-RAIL QXQ		34.F.057
			BUFFER		34.F.058
			BUFFER		34.F.059
			DRAINAGE VENT		34.F.060
			DECOMPRESSION VENTS		34.F.061
			DRAINAGE TYPE XQ XO QXQ		34.F.062
			DRAINAGE TYPE XQ XO QXQ		34.F.063
			DRAINAGE TYPE QXQ QXXQ OXXO		34.F.064
			DRAINAGE TYPE QXQ QXXQ OXXO		34.F.065
			DRAINAGE TYPE XQ XO QXQ		34.F.066
			DRAINAGE TYPE XQ XO QXQ		34.F.067
			DRAINAGE TYPE QXQ QXXQ OXXO		34.F.068
			DRAINAGE TYPE QXQ QXXQ OXXO		34.F.069
			DRAINAGE MONORAIL TYPE XQ		34.F.070
			DRAINAGE MONORAIL TYPE XQ		34.F.071
			DRAINAGE MONORAIL TYPE QXQ		34.F.072
			DRAINAGE MONORAIL TYPE QXQ		34.F.073
			DRAINAGE MONORAIL TYPE QXXQ		34.F.074
			DRAINAGE MONORAIL TYPE QXXQ		34.F.075
			DRAINAGE MONORAIL TYPE XQ		34.F.076
			DRAINAGE MONORAIL TYPE XQ		34.F.077
			DRAINAGE MONORAIL TYPE QXQ		34.F.078
			DRAINAGE MONORAIL TYPE QXQ		34.F.079
			DRAINAGE MONORAIL TYPE QXXQ		34.F.080
			DRAINAGE MONORAIL TYPE QXXQ		34.F.081
			DRAINAGE TYPE XXX XXQ		34.F.082
			DRAINAGE TYPE XXX XXQ		34.F.083

Assembly drawings

CORNER CLEAT	34.F.001
CORNER CLEAT	34.F.002
CORNER CLEAT	34.F.003
SCREW CORNER CONNECTION	34.F.004
SCREW CORNER CONNECTION	34.F.005
CORNER CONNECTION MONORAIL	34.F.006
CORNER CONNECTION MONORAIL	34.F.007
SCREW CORNER CONNECTION MONORAIL	34.F.008
SCREW CORNER CONNECTION MONORAIL	34.F.009
ASSEMBLY OUTER FRAME	34.F.010
ASSEMBLY OUTER FRAME	34.F.011
ASSEMBLY OUTER FRAME MONORAIL	34.F.012
ASSEMBLY OUTER FRAME MONORAIL	34.F.013
ASSEMBLY OUTER FRAME 3-RAIL	34.F.014
ASSEMBLY OUTER FRAME 3-RAIL	34.F.015
CORNER CONNECTION VENT	34.F.016
CORNER CONNECTION VENT	34.F.017
T-CONNECTIONS	34.F.018
T-CONNECTIONS	34.F.019
T-BRACKET WITH SCREW	34.F.020
T-BRACKET WITH DRIVE PIN	34.F.021
T-CONNECTION MONORAIL	34.F.022
T-CONNECTION MONORAIL	34.F.023



DRAINAGE TYPE XXX XXQ	34.F.084
DRAINAGE TYPE XXX XXQ	34.F.085
CONNECTION PIECE	34.F.086
CONNECTION PIECE	34.F.087
GLASS SUPPORTS	34.F.088
ASSEMBLY FIXING PIECE	34.F.089
ASSEMBLY 062.7927.04 / 062.8045.04	34.F.090
ASSEMBLY 062.7927.04 / 062.8045.04	34.F.091
MAX. ADMISSIBLE SIZES VENTS	34.F.092
MAX. ADMISSIBLE SIZES VENTS	34.F.093
MAX. ADMISSIBLE SIZES VENTS	34.F.094
MAX. ADMISSIBLE SIZES VENTS	34.F.095
MAX. ADMISSIBLE SIZES VENTS	34.F.096
MAX. ADMISSIBLE SIZES VENTS	34.F.097
MAX. ADMISSIBLE LENGTHS VENTS	34.F.098
MAX. ADMISSIBLE SIZES VENTS	34.F.099
MAX. ADMISSIBLE SIZES VENTS	34.F.100
MAX. ADMISSIBLE SIZES VENTS	34.F.101
MAX. ADMISSIBLE SIZES VENTS	34.F.102
MAX. ADMISSIBLE SIZES VENTS	34.F.103
BASIC SET AUTOMATIC LIFT AND SLIDING DOOR	34.F.104
BASIC SET AUTOMATIC LIFT AND SLIDING DOOR	34.F.105
ALLGEMEIN	34.F.106
ALLGEMEIN	34.F.107
BASIC SET AUTOMATIC LIFT AND SLIDING DOOR	34.F.108
BASIC SET AUTOMATIC LIFT AND SLIDING DOOR	34.F.109
U-WERTEN	34.F.110
U-WERTEN	34.F.111
BASIC SET AUTOMATIC LIFT AND SLIDING DOOR	34.F.112

Accessories

LIST OF ACCESSORIES	34.G.a01
LIST OF ACCESSORIES	34.G.a02
OVERVIEW	34.G.001
OVERVIEW	34.G.002
OVERVIEW	34.G.003
OVERVIEW	34.G.004
OVERVIEW	34.G.005
OVERVIEW	34.G.006
CRIMP CORNER CLEATS	34.G.007
SCREW CORNER CLEATS	34.G.008
CORNER SUPPORTS	34.G.009
REBATE SUPPORTS	34.G.010
END PIECES	34.G.011
T-CONNECTION	34.G.012
T-CONNECTION	34.G.013
T-BRACKET	34.G.014
SEALING T-BRACKET	34.G.015
T-BRACKET ADJUSTABLE	34.G.016
T-BRACKET ADJUSTABLE	34.G.017
T-BRACKET ADJUSTABLE	34.G.018
DOOR HANDLES	34.G.019
DOOR HANDLES	34.G.020
DOOR HANDLES	34.G.021
DOOR HANDLES	34.G.022
SET SPINDLE + SCREWS	34.G.023
BURGLAR PROTECTION	34.G.024
BURGLAR PROTECTION	34.G.025

LOCKS	34.G.026
HOOK LOCKS	34.G.027
RECEIVERS	34.G.028
CYLINDER	34.G.029
RECEIVERS	34.G.030
BASIC SET LIFT AND SLIDING DOOR	34.G.031
BASIC SET LIFT AND SLIDING DOOR	34.G.032
LOCKS	34.G.033
GLASS SUPPORT	34.G.034
ROLLER	34.G.035
BUFFER	34.G.036
GENERAL ACCESSORIES	34.G.037
GENERAL ACCESSORIES	34.G.038
GENERAL ACCESSORIES	34.G.039
GENERAL ACCESSORIES	34.G.040
GLAZING GASKETS	34.G.041
GLAZING GASKETS	34.G.042
GLAZING GASKETS	34.G.043
GASKETS	34.G.044
GASKETS	34.G.045
END PIECES	34.G.046
END PIECES	34.G.047
BRUSHES	34.G.048
ANCHORINGS	34.G.049
MISCELLANEOUS	34.G.050
MISCELLANEOUS	34.G.051
MISCELLANEOUS	34.G.052
MISCELLANEOUS	34.G.053
MISCELLANEOUS	34.G.054
MISCELLANEOUS	34.G.055
MISCELLANEOUS	34.G.056
FIXINGS	34.G.057
FIXINGS	34.G.058
FIXINGS	34.G.059
FIXINGS	34.G.060
FIXINGS	34.G.061
FIXINGS	34.G.062
FIXINGS	34.G.063
FIXINGS	34.G.064
FIXINGS	34.G.065
FIXINGS	34.G.066
FIXINGS	34.G.067
FIXINGS	34.G.068
FIXINGS	34.G.069
FIXINGS	34.G.070
BASIC SET AUTOMATIC LIFT AND SLIDING DOOR	34.G.071
BASIC SET AUTOMATIC LIFT AND SLIDING DOOR	34.G.072
BORING JIGS AND PUNCH TOOLS	34.G.073
BORING JIGS AND PUNCH TOOLS	34.G.074
BORING JIGS AND PUNCH TOOLS	34.G.075
BORING JIGS AND PUNCH TOOLS	34.G.076
BORING JIGS AND PUNCH TOOLS	34.G.077
BORING JIG	34.G.078
BORING JIGS AND PUNCH TOOLS	34.G.079
BORING JIGS AND PUNCH TOOLS	34.G.080
BORING JIGS AND PUNCH TOOLS	34.G.081
BORING JIGS AND PUNCH TOOLS	34.G.082
MACHINERY AND ACCESSORIES	34.G.083
MACHINERY AND ACCESSORIES	34.G.084



INHALTSANGABE	34.001
INHALTSANGABE	34.002
INHALTSANGABE	34.003
INHALTSANGABE	34.004
INHALTSANGABE	34.005
INHALTSANGABE	34.006
INHALTSANGABE	34.007
INHALTSANGABE	34.008
INHALTSANGABE	34.009
INHALTSANGABE	34.010
INHALTSANGABE	34.011
INHALTSANGABE	34.012
INHALTSANGABE	34.013
INHALTSANGABE	34.014
INHALTSANGABE	34.015
INHALTSANGABE	34.016
INHALTSANGABE	34.017
INHALTSANGABE	34.018
INHALTSANGABE	34.019
INHALTSANGABE	34.020
INHALTSANGABE	34.021
INHALTSANGABE	34.022

Allgemeine Information

ZEICHENERKLAERUNG	34.A.001
ZEICHENERKLAERUNG	34.A.002
ZEICHENERKLAERUNG	34.A.003
ZEICHENERKLAERUNG	34.A.004
ZEICHENERKLAERUNG	34.A.005
ZEICHENERKLAERUNG	34.A.006
ZEICHENERKLAERUNG	34.A.007

Allgemeine Information System

VERARBEITUNGSVORSCHRIFTEN	34.B.001
VERARBEITUNGSVORSCHRIFTEN	34.B.002
VERARBEITUNGSVORSCHRIFTEN	34.B.003
VERARBEITUNGSVORSCHRIFTEN	34.B.004

Profile

PROFILLISTE	34.C.p01
PROFILLISTE	34.C.p02
PROFILUEBERSICHT	34.C.001
PROFILUEBERSICHT	34.C.002
PROFILUEBERSICHT	34.C.003
PROFILUEBERSICHT	34.C.004
PROFILUEBERSICHT	34.C.005
PROFILUEBERSICHT	34.C.006
GLASLEISTEN	34.C.007
ROLLADENFUEHRUNG	34.C.008
ZUSATZPROFILE	34.C.009
BLENDRAHMEN	34.C.010
BLENDRAHMEN	34.C.011
BLENDRAHMEN	34.C.012
BLENDRAHMEN EINBRUCHHEMMEND	34.C.013

BLENDRAHMEN	34.C.014
BLENDRAHMEN MONORAIL	34.C.015
BLENDRAHMEN MONORAIL	34.C.016
ABDECKPROFIL BLENDRAHMEN MONORAIL	34.C.017
BLENDRAHMEN 3-RAIL	34.C.018
BLENDRAHMEN 3-RAIL	34.C.019
BLENDRAHMEN 3-RAIL	34.C.020
FLUEGEL	34.C.021
FLUEGEL EINBRUCHHEMMEND	34.C.022
ZUSATZPROFILE FLUEGEL	34.C.023
ZUSATZPROFILE FLUEGEL	34.C.024
VERSTAERKUNGSPROFILE FLUEGEL	34.C.025
SPROSSEN	34.C.026
SPROSSEN	34.C.027
SPROSSEN	34.C.028
SPROSSEN	34.C.029
WECHSELPROFIL	34.C.030
GLASLEISTEN	34.C.031
GLASLEISTEN	34.C.032
EINBRUCHHEMMEND	34.C.033
EINBRUCHHEMMEND	34.C.034
VERGLASUNGSTABELLE	34.C.035
VERGLASUNGSTABELLE	34.C.036
ROLLADENFUEHRUNGEN	34.C.037
ROLLADENFUEHRUNGEN	34.C.038
AUSDEHNUNGSPROFIL	34.C.039
KUPPLUNGSPROFIL	34.C.040
ZUSATZPROFILE	34.C.041
ZUSATZPROFILE	34.C.042
ZUSATZPROFILE	34.C.043
ZUSATZPROFILE	34.C.044
ABDECKKAPPE ANTRIEB	34.C.045
2-RAIL XQ FLAT BOTTOM	34.C.046
2-RAIL XQ FLAT BOTTOM	

Profilkombinationen

2-RAIL	34.D.001
2-RAIL	34.D.002
2-RAIL	34.D.003
2-RAIL	34.D.004
2-RAIL	34.D.005
2-RAIL	34.D.006
2-RAIL	34.D.007
2-RAIL	34.D.008
2-RAIL	34.D.009
2-RAIL	34.D.010
2-RAIL	34.D.011
2-RAIL	34.D.012
MONORAIL	34.D.013
MONORAIL	34.D.014
MONORAIL	34.D.015
MONORAIL	34.D.016
MONORAIL	34.D.017
MONORAIL	34.D.018
3-RAIL	34.D.019
3-RAIL	34.D.020
3-RAIL	34.D.021



3-RAIL	34.D.022	2-RAIL OXXO	34.E.025
3-RAIL	34.D.023	2-RAIL OXXO	34.E.026
2-RAIL	34.D.024	2-RAIL OXXO	34.E.027
2-RAIL	34.D.025	2-RAIL OXXO	34.E.028
2-RAIL	34.D.026	2-RAIL OXXO	34.E.029
2-RAIL	34.D.027	2-RAIL OXQ	34.E.030
2-RAIL	34.D.028	2-RAIL OXQ	34.E.031
2-RAIL	34.D.029	2-RAIL OXQ	34.E.032
2-RAIL	34.D.030	2-RAIL OXQ	34.E.033
2-RAIL	34.D.031	MONORAIL XQ	34.E.034
2-RAIL	34.D.032	MONORAIL XQ	34.E.035
2-RAIL	34.D.033	MONORAIL XQ	34.E.036
2-RAIL	34.D.034	MONORAIL XQ	34.E.037
2-RAIL	34.D.035	MONORAIL XQX	34.E.038
2-RAIL	34.D.036	MONORAIL XQX	34.E.039
MONORAIL	34.D.037	MONORAIL XQX	34.E.040
MONORAIL	34.D.038	MONORAIL XQX	34.E.041
MONORAIL	34.D.039	MONORAIL QXXQ	34.E.042
MONORAIL	34.D.040	MONORAIL QXXQ	34.E.043
MONORAIL	34.D.041	MONORAIL QXXQ	34.E.044
MONORAIL	34.D.042	MONORAIL QXXQ	34.E.045
MONORAIL	34.D.043	MONORAIL QXXQ	34.E.046
MONORAIL	34.D.044	MONORAIL QXXQ	34.E.047
3-RAIL	34.D.045	3-RAIL XXX	34.E.048
3-RAIL	34.D.046	3-RAIL XXX	34.E.049
3-RAIL	34.D.047	3-RAIL XXX	34.E.050
3-RAIL	34.D.048	3-RAIL XXX	34.E.051
3-RAIL	34.D.049	3-RAIL XXX	34.E.052
2-RAIL QXQ	34.D.050	3-RAIL XXX	34.E.053
2-RAIL FLAT BOTTOM	34.D.051	2-RAIL XQ	34.E.054
2-RAIL FLAT BOTTOM		2-RAIL XO	34.E.055
2-RAIL FLAT BOTTOM	34.D.052	2-RAIL XQ FLAT BOTTOM	34.E.056
		2-RAIL XQ FLAT BOTTOM	34.E.057
		2-RAIL XQ	34.E.058
		2-RAIL XO	34.E.059
		2-RAIL XQ FLAT BOTTOM	34.E.060
		2-RAIL XQ FLAT BOTTOM	34.E.061
		2-RAIL XX	34.E.062
		2-RAIL XX	34.E.063
		2-RAIL XX	34.E.064
		2-RAIL XX	34.E.065
		2-RAIL XX	34.E.066
		2-RAIL XX	34.E.067
		2-RAIL XQX	34.E.068
		2-RAIL XQX	34.E.069
		2-RAIL XQX	34.E.070
		2-RAIL XQX	34.E.071
		2-RAIL XQX	34.E.072
		2-RAIL XQX	34.E.073
		2-RAIL QXXQ	34.E.074
		2-RAIL QXXQ	34.E.075
		2-RAIL QXXQ	34.E.076
		2-RAIL QXXQ	34.E.077
		2-RAIL QXXQ	34.E.078
		2-RAIL QXXQ	34.E.079
		2-RAIL XXXX	34.E.080
		2-RAIL XXXX	34.E.081
		2-RAIL XXXX	34.E.082
		2-RAIL XXXX	34.E.083
		2-RAIL XXXX	34.E.084

Werkzeichnungen

2-RAIL XQ	34.E.001
2-RAIL XQ	34.E.002
2-RAIL XQ	34.E.003
2-RAIL XQ	34.E.004
2-RAIL XQ	34.E.005
2-RAIL XQ VARIANTE HI	34.E.006
2-RAIL XQ VARIANTE HI	34.E.007
2-RAIL XQ VARIANTE HI	34.E.008
2-RAIL XQ VARIANTE HI	34.E.009
2-RAIL XO	34.E.010
2-RAIL XO	34.E.011
2-RAIL XO	34.E.012
2-RAIL XO	34.E.013
2-RAIL XQX	34.E.014
2-RAIL XQX	34.E.015
2-RAIL XQX	34.E.016
2-RAIL XQX	34.E.017
2-RAIL QXXQ	34.E.018
2-RAIL QXXQ	34.E.019
2-RAIL QXXQ	34.E.020
2-RAIL QXXQ	34.E.021
2-RAIL QXXQ	34.E.022
2-RAIL QXXQ	34.E.023
2-RAIL OXXO	34.E.024



2-RAIL XXXX	34.E.084
2-RAIL XXXX	34.E.085
2-RAIL QXQ	34.E.086
2-RAIL QXQ	34.E.087
2-RAIL QXQ	34.E.088
2-RAIL QXQ	34.E.089
MONORAIL XQ	34.E.090
MONORAIL XQ	34.E.091
MONORAIL XQ	34.E.092
MONORAIL XQ	34.E.093
MONORAIL QXQ	34.E.094
MONORAIL QXQ	34.E.095
MONORAIL QXQ	34.E.096
MONORAIL QXQ	34.E.097
MONORAIL QXQ	34.E.098
MONORAIL QXQ	34.E.099
MONORAIL QXXQ	34.E.100
MONORAIL QXXQ	34.E.101
MONORAIL QXXQ	34.E.102
MONORAIL QXXQ	34.E.103
MONORAIL QXXQ	34.E.104
MONORAIL QXXQ	34.E.105
3-RAIL XXX	34.E.106
3-RAIL XXX	34.E.107
3-RAIL XXX	34.E.108
3-RAIL XXX	34.E.109
3-RAIL XXX	34.E.110
3-RAIL XXX	34.E.111
AUTOMATISCHE HEBESCHIEBETUER	34.E.112
AUTOMATISCHE HEBESCHIEBETUER	34.E.113
AUTOMATISCHE HEBESCHIEBETUER	34.E.114
AUTOMATISCHE HEBESCHIEBETUER	34.E.115
AUTOMATISCHE HEBESCHIEBETUER	34.E.116

Montagezeichnungen

ECKVERBINDER	34.F.001
ECKVERBINDER	34.F.002
ECKVERBINDER	34.F.003
SCHRAUBECKWINKELVERBINDUNG	34.F.004
SCHRAUBECKWINKELVERBINDUNG	34.F.005
ECKVERBINDUNG MONORAIL	34.F.006
ECKVERBINDUNG MONORAIL	34.F.007
SCHRAUBECKWINKELVERBINDUNG MONORAIL	34.F.008
SCHRAUBECKWINKELVERBINDUNG MONORAIL	34.F.009
MONTAGE BLENDRAHMEN	34.F.010
MONTAGE BLENDRAHMEN	34.F.011
MONTAGE BLENDRAHMEN MONORAIL	34.F.012
MONTAGE BLENDRAHMEN MONORAIL	34.F.013
MONTAGE BLENDRAHMEN 3-RAIL	34.F.014
MONTAGE BLENDRAHMEN 3-RAIL	34.F.015
ECKVERBINDUNG FLUEGEL	34.F.016
ECKVERBINDUNG FLUEGEL	34.F.017
T-VERBINDUNGEN	34.F.018
T-VERBINDUNGEN	34.F.019
T-VERBINDER MIT SCHRAUBE	34.F.020
T-VERBINDER MIT STIFT	34.F.021
T-VERBINDUNG MONORAIL	34.F.022
T-VERBINDUNG MONORAIL	34.F.023

T-VERBINDUNG MONORAIL	34.F.024
T-VERBINDUNG MONORAIL	34.F.025
MONTAGE ABDICHTUNG MIT BUERSTE	34.F.026
MONTAGE ABDICHTUNG MIT BUERSTE	34.F.027
MONTAGE SCHIEBEFLUEGEL	34.F.028
MONTAGE SCHIEBEFLUEGEL	34.F.029
EINBAU PZ SCHLOSS E	34.F.030
EINBAU PZ-SCHLOSS 4-RAIL	34.F.031
EINBAU 5-FACHVERRIEGELUNG	34.F.032
EINBAU 5-FACHVERRIEGELUNG	34.F.033
EINBAU GRUNDKARTON HEBESCHIEBETUER	34.F.034
EINBAU GRUNDKARTON HEBESCHIEBETUER	34.F.035
EINBAU GRUNDKARTON HEBESCHIEBETUER 4-RAIL	34.F.036
EINBAU GRUNDKARTON HEBESCHIEBETUER 4-RAIL	34.F.037
EINBAU GRUNDKARTON HEBESCHIEBETUER 4-RAIL MIN. 300KG MAX. 400KG	34.F.038
EINBAU GRUNDKARTON HEBESCHIEBETUER 4-RAIL MIN. 300KG MAX. 400KG	34.F.039
EINBAU GRUNDKARTON HEBESCHIEBETUER 4-RAIL	34.F.040
EINBAU GRUNDKARTON HEBESCHIEBETUER 4-RAIL	34.F.041
MONTAGE TUERDRUECKER	34.F.042
MONTAGE TUERDRUECKER	34.F.043
MONTAGE TUERDRUECKER KABA	34.F.044
MONTAGE TUERDRUECKER KABA	34.F.045
EINBRUCHHEMMEND	34.F.046
EINBRUCHHEMMEND	34.F.047
VERBINDUNGEN MIT ANDEREN SYSTEMEN	34.F.048
VERBINDUNGEN MIT ANDEREN SYSTEMEN	34.F.049
BEARBEITEN STULPPROFIL TUERFLUEGEL	34.F.050
BEARBEITEN STULPPROFIL TUERFLUEGEL	34.F.051
BEARBEITEN STULPPROFIL TUERFLUEGEL	34.F.052
BEARBEITEN STULPPROFIL TUERFLUEGEL	34.F.053
2-RAIL AUSSPARUNG BODENPROFIL	34.F.054
2-RAIL AUSSPARUNG BODENPROFIL	34.F.055
BEARBEITEN STULPPROFIL 2-RAIL QXQ	34.F.056
BEARBEITEN STULPPROFIL 2-RAIL QXQ	34.F.057
STOPPER	34.F.058
STOPPER	34.F.059
ENTWAESSERUNG FLUEGEL	34.F.060
DEKOMPRESSION FLUEGELS	34.F.061
ENTWAESSERUNG TYP XQ XO QXQ	34.F.062
ENTWAESSERUNG TYP XQ XO QXQ	34.F.063
ENTWAESSERUNG TYP QXQ QXXQ OXXO	34.F.064
ENTWAESSERUNG TYP QXQ QXXQ OXXO	34.F.065
ENTWAESSERUNG TYP XQ XO QXQ	34.F.066
ENTWAESSERUNG TYP XQ XO QXQ	34.F.067
ENTWAESSERUNG TYP QXQ QXXQ OXXO	34.F.068
ENTWAESSERUNG TYP QXQ QXXQ OXXO	34.F.069
ENTWAESSERUNG MONORAIL TYP XQ	34.F.070
ENTWAESSERUNG MONORAIL TYP XQ	34.F.071
ENTWAESSERUNG MONORAIL TYP QXQ	34.F.072
ENTWAESSERUNG MONORAIL TYP QXQ	34.F.073
ENTWAESSERUNG MONORAIL TYP QXXQ	34.F.074
ENTWAESSERUNG MONORAIL TYP QXXQ	34.F.075
ENTWAESSERUNG MONORAIL TYP XQ	34.F.076
ENTWAESSERUNG MONORAIL TYP XQ	34.F.077
ENTWAESSERUNG MONORAIL TYP QXQ	34.F.078
ENTWAESSERUNG MONORAIL TYP QXQ	34.F.079
ENTWAESSERUNG MONORAIL TYP QXXQ	34.F.080
ENTWAESSERUNG MONORAIL TYP QXXQ	34.F.081
ENTWAESSERUNG TYPE XXX XXQ	34.F.082
ENTWAESSERUNG TYPE XXX XXQ	34.F.083















ENTWAESSERUNG TYPE XXX XXQ	34.F.084
ENTWAESSERUNG TYPE XXX XXQ	34.F.085
KUPPLUNGSSTUECK	34.F.086
KUPPLUNGSSTUECK	34.F.087
KLOTZBRUECKEN	34.F.088
MONTAGE BEFESTIGUNGSKLOTZ	34.F.089
MONTAGE 062.7927.04 / 062.8045.04	34.F.090
MONTAGE 062.7927.04 / 062.8045.04	34.F.091
MAX. ZULAESSIGE ABMESSUNGEN FLUEGELS	34.F.092
MAX. ZULAESSIGE ABMESSUNGEN FLUEGELS	34.F.093
MAX. ZULAESSIGE ABMESSUNGEN FLUEGELS	34.F.094
MAX. ZULAESSIGE ABMESSUNGEN FLUEGELS	34.F.095
MAX. ZULAESSIGE ABMESSUNGEN FLUEGELS	34.F.096
MAX. ZULAESSIGE ABMESSUNGEN FLUEGELS	34.F.097
MAX ZULAESSIGE LAENGEN FLUEGELS	34.F.098
MAX. ZULAESSIGE ABMESSUNGEN FLUEGELS	34.F.099
MAX. ZULAESSIGE ABMESSUNGEN FLUEGELS	34.F.100
MAX. ZULAESSIGE ABMESSUNGEN FLUEGELS	34.F.101
MAX. ZULAESSIGE ABMESSUNGEN FLUEGELS	34.F.102
MAX. ZULAESSIGE ABMESSUNGEN FLUEGELS	34.F.103
GRUNDKARTON AUTOMATISCHE HEBESCHIEBETUER	34.F.104
GRUNDKARTON AUTOMATISCHE HEBESCHIEBETUER	34.F.105
GENERAL	34.F.106
GENERAL	34.F.107
GRUNDKARTON AUTOMATISCHE HEBESCHIEBETUER	34.F.108
GRUNDKARTON AUTOMATISCHE HEBESCHIEBETUER	34.F.109
U-VALUES	34.F.110
U-VALUES	34.F.111
GRUNDKARTON AUTOMATISCHE HEBESCHIEBETUER	34.F.112







Zubehör







LISTE VON ZUBEHOER	34.G.a01
LISTE VON ZUBEHOER	34.G.a02
UEBERSICHT	34.G.001
UEBERSICHT	34.G.002
UEBERSICHT	34.G.003
UEBERSICHT	34.G.004
UEBERSICHT	34.G.005
UEBERSICHT	34.G.006
PRESSECKWINKEL	34.G.007
SCHRAUBECKWINKEL	34.G.008
FUELLECKWINKEL	34.G.009
ECKWINKEL GLASANSCHLAG	34.G.010
ENDKAPPEN	34.G.011
T-VERBINDUNG	34.G.012
T-VERBINDUNG	34.G.013
T-VERBINDER	34.G.014
ABDICHTUNG T-VERBINDER	34.G.015
T-VERBINDER VERSTELLBAR	34.G.016
T-VERBINDER VERSTELLBAR	34.G.017
T-VERBINDER VERSTELLBAR	34.G.018
TUERDRUECKER	34.G.019
TUERDRUECKER	34.G.020
TUERDRUECKER	34.G.021
TUERDRUECKER	34.G.022
SATZ STIFT + SCHRAUBEN	34.G.023
EINBRUCHHEMMEND	34.G.024
EINBRUCHHEMMEND	34.G.025







SCHLOESSER	34.G.026
HAKENSCHLOSS	34.G.027
SCHLIESSBLECHE	34.G.028
ZYLINDER	34.G.029
SCHLIESSBLECHE	34.G.030
GRUNDKARTON HEBESCHIEBETUER	34.G.031
GRUNDKARTON HEBESCHIEBETUER	34.G.032
SCHLOESSER	34.G.033
GLASAUFLAGEPROFIL	34.G.034
LAUFRAD	34.G.035
STOPPER	34.G.036
ALLGEMEINES ZUBEHOER	34.G.037
ALLGEMEINES ZUBEHOER	34.G.038
ALLGEMEINES ZUBEHOER	34.G.039
ALLGEMEINES ZUBEHOER	34.G.040
VERGLASUNGSDICHTUNGEN	34.G.041
VERGLASUNGSDICHTUNGEN	34.G.042
VERGLASUNGSDICHTUNGEN	34.G.043
DICHTUNGEN	34.G.044
DICHTUNGEN	34.G.045
ABDICHTUNGEN	34.G.046
ABDICHTUNGEN	34.G.047
BUERSTENDICHTUNGEN	34.G.048
VERANKERUNGEN	34.G.049
DIVERSE	34.G.050
DIVERSE	34.G.051
DIVERSE	34.G.052
DIVERSE	34.G.053
DIVERSE	34.G.054
DIVERSE	34.G.055
DIVERSE	34.G.056
BEFESTIGUNGSMITTEL	34.G.057
BEFESTIGUNGSMITTEL	34.G.058
BEFESTIGUNGSMITTEL	34.G.059
BEFESTIGUNGSMITTEL	34.G.060
BEFESTIGUNGSMITTEL	34.G.061
BEFESTIGUNGSMITTEL	34.G.062
BEFESTIGUNGSMITTEL	34.G.063
BEFESTIGUNGSMITTEL	34.G.064
BEFESTIGUNGSMITTEL	34.G.065
BEFESTIGUNGSMITTEL	34.G.066
BEFESTIGUNGSMITTEL	34.G.067
BEFESTIGUNGSMITTEL	34.G.068
BEFESTIGUNGSMITTEL	34.G.069
BEFESTIGUNGSMITTEL	34.G.070
GRUNDKARTON AUTOMATISCHE HEBESCHIEBETUER	34.G.071
GRUNDKARTON AUTOMATISCHE HEBESCHIEBETUER	34.G.072
BOHRLEHREN UND STANZWERKZEUGE	34.G.073
BOHRLEHREN UND STANZWERKZEUGE	34.G.074
BOHRLEHREN UND STANZWERKZEUGE	34.G.075
BOHRLEHREN UND STANZWERKZEUGE	34.G.076
BOHRLEHREN UND STANZWERKZEUGE	34.G.077
BOHRLEHRE	34.G.078
BOHRLEHREN UND STANZWERKZEUGE	34.G.079
BOHRLEHREN UND STANZWERKZEUGE	34.G.080
BOHRLEHREN UND STANZWERKZEUGE	34.G.081
BOHRLEHREN UND STANZWERKZEUGE	34.G.082
MASCHINEN UND ZUBEHOER	34.G.083
MASCHINEN UND ZUBEHOER	34.G.084







					
34.001	02/2009		34.C.010	02/2009	D0013843
34.002	02/2009		34.C.011	02/2009	D0013844
34.003	02/2009		34.C.012	02/2009	D0013845
34.004	02/2009		34.C.013	02/2009	D0013846
34.005	02/2009		34.C.014	02/2009	D0013847
34.006	02/2009		34.C.015	02/2009	D0013848
34.007	02/2009		34.C.016	02/2009	D0013849
34.008	02/2009		34.C.017	02/2009	D0013850
34.009	02/2009		34.C.018	02/2009	D0044533
34.010	02/2009		34.C.019	02/2009	D0044575
34.011	02/2009		34.C.020	02/2009	D0044579
34.012	02/2009		34.C.021	02/2009	D0013851
34.013	02/2009		34.C.022	02/2009	D0013852
34.014	02/2009		34.C.023	02/2009	D0013854
34.015	02/2009		34.C.024	02/2009	D0013853
34.016	02/2009		34.C.025	02/2009	D0013855
34.017	02/2009		34.C.026	02/2009	D0013856
34.018	02/2009		34.C.027	02/2009	D0075003
34.019	02/2009		34.C.028	02/2009	D0013857
34.020	02/2009		34.C.029	02/2009	D0013858
34.021	02/2009		34.C.030	02/2009	D0046576
34.022	02/2009		34.C.031	02/2009	D0044306
34.A.001	02/2009	D0062175	34.C.032	02/2009	D0013861
34.A.002	02/2009	D0063002	34.C.033	02/2009	D0013860
34.A.003	02/2009	D0063003	34.C.034	02/2009	D0013859
34.A.004	02/2009	D0065223	34.C.035	02/2009	D0013862
34.A.005	02/2009	D0065224	34.C.036	02/2009	D0013863
34.A.006	02/2009	D0065225	34.C.037	02/2009	D0013865
34.A.007	02/2009	D0065226	34.C.038	02/2009	D0013864
34.A.008	02/2009		34.C.039	02/2009	D0074999
34.B.001	02/2009	D0056487	34.C.040	02/2009	D0075000
34.B.002	02/2009	D0056489	34.C.041	02/2009	D0013866
34.B.003	02/2009	D0056490	34.C.042	02/2009	D0013867
34.B.004	02/2009	D0056491	34.C.043	02/2009	D0013868
34.C.p01	02/2009		34.C.044	02/2009	D0013869
34.C.p02	02/2009		34.C.045	02/2009	D0059657
34.C.001	02/2009	D0013876	34.C.046	02/2009	D0074761
34.C.002	02/2009	D0013875	34.D.001	02/2009	D0072998
34.C.003	02/2009	D0013874	34.D.002	02/2009	D0072997
34.C.004	02/2009	D0013873	34.D.003	02/2009	D0045945
34.C.005	02/2009	D0013877	34.D.004	02/2009	D0013879
34.C.006	02/2009	D0044590	34.D.005	02/2009	D0013880
34.C.007	02/2009	D0044610	34.D.006	02/2009	D0045532
34.C.008	02/2009	D0045791	34.D.007	02/2009	D0072995
34.C.009	02/2009	D0045793	34.D.008	02/2009	D0072996

					
34.D.009	02/2009	D0013881	34.E.002	02/2009	D0013911
34.D.010	02/2009	D0013882	34.E.003	02/2009	D0013911
34.D.011	02/2009	D0013883	34.E.004	02/2009	D0013912
34.D.012	02/2009	D0013884	34.E.005	02/2009	D0013912
34.D.013	02/2009	D0013885	34.E.006	02/2009	D0073972
34.D.014	02/2009	D0013886	34.E.007	02/2009	D0073972
34.D.015	02/2009	D0013887	34.E.008	02/2009	D0073973
34.D.016	02/2009	D0013888	34.E.009	02/2009	D0073973
34.D.017	02/2009	D0013889	34.E.010	02/2009	D0013913
34.D.018	02/2009	D0013890	34.E.011	02/2009	D0013913
34.D.019	02/2009	D0046238	34.E.012	02/2009	D0013914
34.D.020	02/2009	D0046239	34.E.013	02/2009	D0013914
34.D.021	02/2009	D0046240	34.E.014	02/2009	D0013915
34.D.022	02/2009	D0046241	34.E.015	02/2009	D0013915
34.D.023	02/2009	D0046242	34.E.016	02/2009	D0013916
34.D.024	02/2009	D0013891	34.E.017	02/2009	D0013916
34.D.025	02/2009	D0072928	34.E.018	02/2009	D0013917
34.D.026	02/2009	D0013892	34.E.019	02/2009	D0013917
34.D.027	02/2009	D0072929	34.E.020	02/2009	D0013918
34.D.028	02/2009	D0013893	34.E.021	02/2009	D0013918
34.D.029	02/2009	D0072930	34.E.022	02/2009	D0013919
34.D.030	02/2009	D0045553	34.E.023	02/2009	D0013919
34.D.031	02/2009	D0072933	34.E.024	02/2009	D0013920
34.D.032	02/2009	D0013894	34.E.025	02/2009	D0013920
34.D.033	02/2009	D0013895	34.E.026	02/2009	D0013921
34.D.034	02/2009	D0013896	34.E.027	02/2009	D0013921
34.D.035	02/2009	D0013897	34.E.028	02/2009	D0013922
34.D.036	02/2009	D0013898	34.E.029	02/2009	D0013922
34.D.037	02/2009	D0013899	34.E.030	02/2009	D0046634
34.D.038	02/2009	D0013900	34.E.031	02/2009	D0046634
34.D.039	02/2009	D0013901	34.E.032	02/2009	D0046635
34.D.040	02/2009	D0013902	34.E.033	02/2009	D0046635
34.D.041	02/2009	D0013903	34.E.034	02/2009	D0013923
34.D.042	02/2009	D0013904	34.E.035	02/2009	D0013923
34.D.043	02/2009	D0013905	34.E.036	02/2009	D0013924
34.D.044	02/2009	D0013906	34.E.037	02/2009	D0013924
34.D.045	02/2009	D0046245	34.E.038	02/2009	D0013925
34.D.046	02/2009	D0046252	34.E.039	02/2009	D0013925
34.D.047	02/2009	D0046255	34.E.040	02/2009	D0013926
34.D.048	02/2009	D0046256	34.E.041	02/2009	D0013926
34.D.049	02/2009	D0046257	34.E.042	02/2009	D0013927
34.D.050	02/2009	D0075256	34.E.043	02/2009	D0013927
34.D.051	02/2009	D0074740	34.E.044	02/2009	D0013928
34.D.052	02/2009		34.E.045	02/2009	D0013928
34.E.001	02/2009		34.E.046	02/2009	D0013929
			34.E.047	02/2009	D0013929

					
34.E.048	02/2009	D0045159	34.E.093	02/2009	D0013943
34.E.049	02/2009	D0045159	34.E.094	02/2009	D0013944
34.E.050	02/2009	D0045149	34.E.095	02/2009	D0013944
34.E.051	02/2009	D0045149	34.E.096	02/2009	D0013945
34.E.052	02/2009	D0045153	34.E.097	02/2009	D0013945
34.E.053	02/2009	D0045153	34.E.098	02/2009	D0045123
34.E.054	02/2009	D0013930	34.E.099	02/2009	D0045123
34.E.055	02/2009	D0013930	34.E.100	02/2009	D0013946
34.E.056	02/2009	D0074742	34.E.101	02/2009	D0013946
34.E.057	02/2009	D0074742	34.E.102	02/2009	D0013947
34.E.058	02/2009	D0013931	34.E.103	02/2009	D0013947
34.E.059	02/2009	D0013931	34.E.104	02/2009	D0013948
34.E.060	02/2009	D0074743	34.E.105	02/2009	D0013948
34.E.061	02/2009	D0074743	34.E.106	02/2009	D0044654
34.E.062	02/2009	D0013932	34.E.107	02/2009	D0044654
34.E.063	02/2009	D0013932	34.E.108	02/2009	D0044639
34.E.064	02/2009	D0013933	34.E.109	02/2009	D0044639
34.E.065	02/2009	D0013933	34.E.110	02/2009	D0045164
34.E.066	02/2009	D0044934	34.E.111	02/2009	D0045164
34.E.067	02/2009	D0044934	34.E.112	02/2009	D0059817
34.E.068	02/2009	D0013934	34.E.113	02/2009	D0059817
34.E.069	02/2009	D0013934	34.E.114	02/2009	D0059815
34.E.070	02/2009	D0013935	34.E.115	02/2009	D0059815
34.E.071	02/2009	D0013935	34.E.116	02/2009	
34.E.072	02/2009	D0044956	34.F.001	02/2009	
34.E.073	02/2009	D0044956	34.F.002	02/2009	D0013951
34.E.074	02/2009	D0013936	34.F.003	02/2009	D0013951
34.E.075	02/2009	D0013936	34.F.004	02/2009	D0013952
34.E.076	02/2009	D0013937	34.F.005	02/2009	D0013952
34.E.077	02/2009	D0013937	34.F.006	02/2009	D0013953
34.E.078	02/2009	D0013938	34.F.007	02/2009	D0013953
34.E.079	02/2009	D0013938	34.F.008	02/2009	D0013954
34.E.080	02/2009	D0013939	34.F.009	02/2009	D0013954
34.E.081	02/2009	D0013939	34.F.010	02/2009	D0013955
34.E.082	02/2009	D0013940	34.F.011	02/2009	D0013955
34.E.083	02/2009	D0013940	34.F.012	02/2009	D0013956
34.E.084	02/2009	D0013941	34.F.013	02/2009	D0013956
34.E.085	02/2009	D0013941	34.F.014	02/2009	D0046824
34.E.086	02/2009	D0046860	34.F.015	02/2009	D0046824
34.E.087	02/2009	D0046860	34.F.016	02/2009	D0013957
34.E.088	02/2009	D0046869	34.F.017	02/2009	D0013957
34.E.089	02/2009	D0046869	34.F.018	02/2009	D0013958
34.E.090	02/2009	D0013942	34.F.019	02/2009	D0013958
34.E.091	02/2009	D0013942	34.F.020	02/2009	D0013959
34.E.092	02/2009	D0013943	34.F.021	02/2009	D0013959

					
34.F.022	02/2009	D0013960	34.F.067	02/2009	D0013979
34.F.023	02/2009	D0013960	34.F.068	02/2009	D0013980
34.F.024	02/2009	D0013961	34.F.069	02/2009	D0013980
34.F.025	02/2009	D0013961	34.F.070	02/2009	D0013981
34.F.026	02/2009	D0075233	34.F.071	02/2009	D0013981
34.F.027	02/2009	D0075233	34.F.072	02/2009	D0013982
34.F.028	02/2009	D0013962	34.F.073	02/2009	D0013982
34.F.029	02/2009	D0013962	34.F.074	02/2009	D0013983
34.F.030	02/2009	D0013963	34.F.075	02/2009	D0013983
34.F.031	02/2009	D0013963	34.F.076	02/2009	D0013984
34.F.032	02/2009	D0013965	34.F.077	02/2009	D0013984
34.F.033	02/2009	D0013965	34.F.078	02/2009	D0013985
34.F.034	02/2009	D0013966	34.F.079	02/2009	D0013985
34.F.035	02/2009	D0013966	34.F.080	02/2009	D0013986
34.F.036	02/2009	D0013967	34.F.081	02/2009	D0013986
34.F.037	02/2009	D0013967	34.F.082	02/2009	D0046849
34.F.038	02/2009	D0075276	34.F.083	02/2009	D0046849
34.F.039	02/2009	D0075276	34.F.084	02/2009	D0046856
34.F.040	02/2009	D0013968	34.F.085	02/2009	D0046856
34.F.041	02/2009	D0013968	34.F.086	02/2009	D0074908
34.F.042	02/2009	D0013969	34.F.087	02/2009	D0074908
34.F.043	02/2009	D0013969	34.F.088	02/2009	D0075052
34.F.044	02/2009	D0075075	34.F.089	02/2009	D0075052
34.F.045	02/2009	D0075075	34.F.090	02/2009	D0075263
34.F.046	02/2009	D0013970	34.F.091	02/2009	D0075263
34.F.047	02/2009	D0013970	34.F.092	02/2009	D0013987
34.F.048	02/2009	D0013971	34.F.093	02/2009	D0013987
34.F.049	02/2009	D0013971	34.F.094	02/2009	D0013988
34.F.050	02/2009	D0013972	34.F.095	02/2009	D0013988
34.F.051	02/2009	D0013972	34.F.096	02/2009	D0013990
34.F.052	02/2009	D0013973	34.F.097	02/2009	D0013990
34.F.053	02/2009	D0013973	34.F.098	02/2009	D0013993
34.F.054	02/2009	D0075268	34.F.099	02/2009	D0013993
34.F.055	02/2009	D0075268	34.F.100	02/2009	D0013995
34.F.056	02/2009	D0075115	34.F.101	02/2009	D0013995
34.F.057	02/2009	D0075115	34.F.102	02/2009	D0013997
34.F.058	02/2009	D0013974	34.F.103	02/2009	D0013997
34.F.059	02/2009	D0013974	34.F.104	02/2009	D0059816
34.F.060	02/2009	D0013975	34.F.105	02/2009	D0059816
34.F.061	02/2009	D0013975	34.F.106	02/2009	D0072459
34.F.062	02/2009	D0013977	34.F.107	02/2009	D0072459
34.F.063	02/2009	D0013977	34.F.108	02/2009	D0059814
34.F.064	02/2009	D0013978	34.F.109	02/2009	D0059814
34.F.065	02/2009	D0013978	34.F.110	02/2009	D0075072
34.F.066	02/2009	D0013979	34.F.111	02/2009	D0075072

					
34.F.112	02/2009		34.G.041	02/2009	D0014036
34.G.a01	02/2009		34.G.042	02/2009	D0014037
34.G.a02	02/2009		34.G.043	02/2009	D0045280
34.G.i01	02/2009		34.G.044	02/2009	D0014038
34.G.i02	02/2009		34.G.045	02/2009	D0045283
34.G.001	02/2009	D0075500	34.G.046	02/2009	D0014039
34.G.002	02/2009	D0075501	34.G.047	02/2009	D0014040
34.G.003	02/2009	D0075502	34.G.048	02/2009	D0014041
34.G.004	02/2009	D0075503	34.G.049	02/2009	D0014042
34.G.005	02/2009	D0075504	34.G.050	02/2009	D0014043
34.G.006	02/2009	D0075505	34.G.051	02/2009	D0014044
34.G.007	02/2009	D0014004	34.G.052	02/2009	D0014045
34.G.008	02/2009	D0014005	34.G.053	02/2009	D0014046
34.G.009	02/2009	D0014006	34.G.054	02/2009	D0014047
34.G.010	02/2009	D0014007	34.G.055	02/2009	D0014048
34.G.011	02/2009	D0045257	34.G.056	02/2009	D0014049
34.G.012	02/2009	D0014008	34.G.057	02/2009	D0068363
34.G.013	02/2009	D0014009	34.G.058	02/2009	D0068364
34.G.014	02/2009	D0014010	34.G.059	02/2009	D0068365
34.G.015	02/2009	D0014013	34.G.060	02/2009	D0068366
34.G.016	02/2009	D0014014	34.G.061	02/2009	D0068368
34.G.017	02/2009	D0014015	34.G.062	02/2009	D0068367
34.G.018	02/2009	D0014016	34.G.063	02/2009	D0068369
34.G.019	02/2009	D0014017	34.G.064	02/2009	D0068370
34.G.020	02/2009	D0014018	34.G.065	02/2009	D0068371
34.G.021	02/2009	D0075081	34.G.066	02/2009	D0068372
34.G.022	02/2009	D0014019	34.G.067	02/2009	D0068373
34.G.023	02/2009	D0014020	34.G.068	02/2009	D0068374
34.G.024	02/2009	D0014021	34.G.069	02/2009	D0068376
34.G.025	02/2009	D0014022	34.G.070	02/2009	D0068377
34.G.026	02/2009	D0075082	34.G.071	02/2009	D0059648
34.G.027	02/2009	D0014023	34.G.072	02/2009	D0059652
34.G.028	02/2009	D0014024	34.G.073	02/2009	D0014058
34.G.029	02/2009	D0014025	34.G.074	02/2009	D0014059
34.G.030	02/2009	D0014026	34.G.075	02/2009	D0014060
34.G.031	02/2009	D0014027	34.G.076	02/2009	D0014061
34.G.032	02/2009	D0014028	34.G.077	02/2009	D0014062
34.G.033	02/2009	D0075261	34.G.078	02/2009	D0059656
34.G.034	02/2009	D0014029	34.G.079	02/2009	D0014063
34.G.035	02/2009	D0014030	34.G.080	02/2009	D0074792
34.G.036	02/2009	D0014031	34.G.081	02/2009	D0074793
34.G.037	02/2009	D0014032	34.G.082	02/2009	D0074794
34.G.038	02/2009	D0014033	34.G.083	02/2009	D0014067
34.G.039	02/2009	D0014034	34.G.084	02/2009	D0046322
34.G.040	02/2009	D0014035	34.G.085	02/2009	D0046323

					
34.G.086	02/2009	D0046324			
34.G.087	02/2009	D0046328			
34.G.088	02/2009	D0046331			
34.G.089	02/2009	D0046332			
34.G.090	02/2009	D0046330			
34.G.091	02/2009	D0046333			
34.G.092	02/2009	D0046335			
34.G.093	02/2009	D0075005			
34.G.094	02/2009	D0014068			

A































Algemene informatie



































Généralités





























General Information



































Allgemeine Information



































	Profiel Profilé Profile Profil	Perfil Profil Profil		Verstek Onglet Mitre Gehrung	Inglete Polaczenie katowe Taglio
	Anodisatie- of lakoppervlakte Surface anodisée ou laquée Anodizing or coating surface Eloxierte oder lackierte Oberfläche	Superficie anodizada o lacada Powierzchnia anodowana lub malowana Superficie anodizzata o verniciata	#	Aantal Nombre Number Anzahl	Número Ilość Numero
	Polijsoppervlakte Surface à polir Polishing surface Polieroberfläche	Superficie pulida Powierzchnia polerowana Superficie lucidata		Zie pagina Voir page See page Siehe Seite	Ver página Patrz strona Vedi pagina
	Lengte Longueur Length Länge	Longitud Długość Lunghezza		Type toebehoren Type accessoires Type accessories Typ Zubehör	Tipos de accesorios Rodzaj okuc Tipo di accessorio
	Afmetingen Dimensions Dimensions Abmessungen	Dimensiones Wymiary Dimensioni		Glasmaten Dimensions vitres Glass sizes Glasmasse	Dimensiones de los vidrios Wymiary szyby Dimensioni del vetro
	Toepassing Application Application Anwendung	Aplicación Zastosowanie Utilizzo		Toepassing Application Utilization Anwendung	Aplicación Zastosowanie Riferimenti
	Bevestigingsmiddelen Moyens de fixation Fixations Befestigungsmittel	Fijación Mocowanie Fissaggio		Asymmetrisch profiel Profilé asymétrique Asymmetrical profile Asymmetrisches Profil	Perfil asimétrico Profil niesymetryczny Profilo asimmetrico
	Schroeven niet meegeleverd Fourniture sans vis Delivered without screws Lieferung ohne Schrauben	Entregado sin tornillos Dostarczane bez wkrętów Consegnato senza viti		Pagina Page Page Seite	Página Strona Pagina
	1 2 3 Montagevolgorde Ordre de montage The order of assembly Montagerihenfolge	Orden de montaje Kolejność montażu Ordine di montaggio		Laatste editie Dernière édition Last edition Letzte Edition	Edición Poprzednie wydanie Ultima edizione
	Dichtingsmiddel Matière d'étanchéité Sealing agent Abdichtungsmittel	Agente sellante Masa uszczelniająca Siliconatura		Vorige blz Page précédente Previous page Vorige Seite	Página siguiente Poprzednia strona -
	Verlijmen Coller Glue Verkleben	Collado Klej Colla			
	Vulcaniseerlijm Colle vulcanisante Vulcanizing glue Vulkanisierkleber	Vulcanizante Klej wulkanizacyjny Colla vulcanizzante			
	Referentiemaat Dimension de référence Reference dimension Referenzmass	Dimension de referencia Punkt odniesienia wymiarowania Dimensioni di riferimento			
	Merkteken Marquage Mark Merkzeichen	Indicación Znak Contrassegno			
	Struktureel gelijmd glaswerk Vitrage extérieur collé Structural sealing glazing UV-beständiger Scheibenrandverbund	Sellado acristalado estructural Szyba klejona spoiwem konstrukcyjnym Siliconatura vetro strutturale			
	Primaire zichtzijde van een profiel Côté visible primaire d'un profilé Primary visible side of a profile Primäre sichtbare Seite eines Profils Secundaire zichtzijde van een profiel Côté visible secondaire d'un profilé Secondary visible side of a profile Sekund. sichtbare Seite eines Profils	Cara vista principal del perfil Główna widoczna powierzchnia profilu Primo lato visibile di un profilo Cara vista secundaria del perfil Drugorzędna widoczna powierzchnia profilu Secondo lato visibile di un profilo			
	Bicolor Kleur buitenschaal (e) eerst aangeven in geval van bicolor (.69) En cas de bicolore (.69) il faut indiquer d'abord la couleur du profilé extérieur (e) For bicolor profiles (.69) first of all one should indicate the colour of the outer profile (e) Falls zweifarbig (.69) soll man erst die Farbe des Aussenprofils (e) angeben	Para perfil en bicolor (.69) debe indicarse primero el color del perfil externo (e) Dla profili dwukolorowych (.69) w pierwszej kolejności powinny być wskazany kolor zewnętrznej strony profilu (e) Nei profili bicolore (.69) prima di tutto indicare il colore del profilo esterno (e)			

























	Inbraakwerend Anti-vol Burglar proof Einbruchhemmend	Protección anti-robo Antywłamaniowe -		Pershoekverbinding Equerre à serti Crimp corner cleat Presseckverbinder	Escuadra de ensamblar Naroznik zaciskany Squadrette a cianfrinare
	Basisveiligheid Sécurité de base Basic safety Basissicherheit	Seguridad básica Antywłamaniowosc podstawowa -		Hoekverbinding met schroefhoek (* enkel voor klembaar beslag Equerre à blocage (* seulement pour accessoires encastrables Corner cleat with screw (* only for clamping accessories Eckverbinder mit Spanschraube (* nur für klemmbaren Beschlag	Escuadra de atornillar (* solo para accesorios apretables Naroznik skrecany (* tylko dla akcesoriow zatrzaszkowanych Squadrette ad avvitare (* solo per accessori a scatto
	Testen uitgevoerd volgens norm DIN V ENV 1627 Essais effectués par conformément la norme DIN V ENV 1627 Tests carried out according to standard DIN V ENV 1627 Einbruchhemmende Prüfungen gemäß Norm DIN V ENV 1627	Ensayos realizados según norma DIN V ENV 1627 Badania wykonane według normy DIN V ENV 1627 -		T-verbinding met schroef Jonction-T avec vis T-bracket with screw T-Verbinder mit Schraube	Tope de union con tornillo Lacznik teowy skrecany Giunti con viti
	Testen uitgevoerd volgens norm NEN 5096 + ENV 1627 Essais effectués par conformément la norme NEN 5096 + ENV 1627 Tests carried out according to standard NEN 5096 + ENV 1627 Einbruchhemmende Prüfungen gemäß Norm NEN5096 + ENV1627	Ensayos realizados según norma NEN 5096 + ENV 1627 Badania wykonane norm NEN 5098 + ENV 1627 -		T-verbinding met schroef voor buitendraaiend raam Jonction-T avec vis pour fenêtre ouvrant vers l'ext. T-bracket with screw outside opening window T-Verbinder mit Schraube ausßen öffnendes Fenster	Tope Unión con tornillo apertura exterior Lacznik teowy skrecany do okien otwieranych na zewnątrz -
	Testen uitgevoerd door instituut IBS (Oostenrijk) volgens norm Ö B 3800/3850 Essais effectués par IBS(Autriche) conformément la norme Ö B 3800/3850 Tests carried out by IBS (Austria) according to standard Ö B 3800/3850 Brandschutzprüfungen durch- geführt beim IBS (Österreich) gemäß Norm Ö B 3800/3850	Ensayos hechos por IBS (Austria) según la estandard Ö B 3800/3850 Badania wykonane przez IBS (Austria) według norm Ö B 3800/3850 -		Vulhoek Equerre de remplissage Corner support Fülleckwinkel	Escuadra de relleno Wspornik narozny Supporto d'angolo
	Testen uitgevoerd door instituut TNO (Nederland) volgens norm NEN 6069:1997 Essais effectués par TNO (Hollande) conformément la norme NEN 6069:1997 Tests carried out by TNO (The Netherlands) according to standard NEN 6069/1997 Brandschutzprüfungen durch- geführt beim TNO (Die Niederlande) gemäß Norm NEN 6069/1997	Ensayos realizados fuera por TNO(Holanda) según norma NEN 6069/1977 Badania wykonane przez TNO (Holandia) według norm NEN 6069/1977 -		Steunhoek Cale de feuillure Rebate support Glasanschlagwinkel	Escuadra de alineamiento Katowy naroznik Squadrette di allineamento
	Testen uitgevoerd door instituut TNO (Nederland) volgens norm NEN 6069:1997 Essais effectués par TNO (Hollande) conformément la norme NEN 6069:1997 Tests carried out by TNO (The Netherlands) according to standard NEN 6069/1997 Brandschutzprüfungen durch- geführt beim TNO (Die Niederlande) gemäß Norm NEN 6069/1997	Ensayos realizados fuera por TNO(Holanda) según norma NEN 6069/1977 Badania wykonane przez TNO (Holandia) według norm NEN 6069/1977 -		Verstelbare schroefhoek Equerre à visser réglable Adjustable screw corner cleat Verstellbarer Schraubewinkel	Escuadra de atornillar regulable Katowy naroznik skrecany Squadrette ad avvitare regolabili
	Brandwerend Anti-feu Fire-proof Feuerhemmend	Resistente al fuego Ognioodporne -		Steunhoeken verstelbaar Cales de feuillure réglables Rebate supports adjustable Verstellbare Eckwinkel Glasanschlag	Escuadra de alineamiento regulable Katowy naroznik nastawny Squadrette di allineamento regolabile
	Toebehoren brandwerend Accessoires anti-feu Fire-proof accessories Feuerhemmender Zubehör	Accesorios resistente al fuego Akcesoria ognioodporne -		Hoekverbinding met nagel Equerre avec cheville Corner cleat with drive pin Eckverbinder mit Stift	Escuadra con clavia Lacznik narozny sworzniowy -
	Gelaagd glas Verre feuilleté Laminated glass Verbundglas	Vidrio Laminado Szyba laminowana -		T-verbinding met nagel Jonction-T avec cheville T-bracket with drive pin T-Verbinder mit Stift	Tope de union con clavia Lacznik teowy sworzniowy -
	Glas Verre Glass Glas	Vidrio Szyba -		T-verbinding met nagel voor buitendraaiend raam Jonction-T avec cheville pour fenêtre ouvrant vers l'ext. T-bracket with drive pin outward opening window T-Verbinder mit Stift nach ausßen öffnendes Fenster	Lacznik teowy sworzniowy do okien otwieranych na zewnątrz -
	Handleiding Manuel Manual Gebrauchsanweisung	Manual Instrukcja -		Verstelbare T-verbinding Jonction-T réglable Adjustable T-bracket Verstellbarer T-Verbinder	Union T regulable Lacznik teowy nastawny Giunti a T regolabili
	Alleen voor CS 59 Seulement pour CS 59 Only for CS 59 Nur für CS 59	Solo para CS 59 Tylko do CS 59 -		Kruisverbindingen Jonctions transversales Cross connections Kreuzverbindungen	Uniones transversales Polaczenie krzyzowe -
	Alleen voor CS 68 Seulement pour CS 68 Only for CS 68 Nur für CS 68	Solo para CS 68 Tylko do CS 68 -		Kruisverbinding met schroef Jonction transversale avec vis Cross connection with screw Kreuzverbindung mit Schraube	Union transversal con tornillo Polaczenie krzyzowe skrecane -
	Alleen voor CS 77 Seulement pour CS 77 Only for CS 77 Nur für CS 77	Solo para CS 77 Tylko do CS 77 -		Bevestiging drager Fixation chevon Fixation rafter Befestigung Dachsparren	Fijacion mainel Mocowanie krokwi -

	Eénpuntsluiting Fermeture à 1 point 1-Point lock Einfachverriegelung	Cerradura de 1 punto Zamek 1-punktowy Serratura a 1 punto di chiusura		Elektrische deurpener Gâche pour serrure électrique Electric door opener Elektrischer Türöffner	Portero automatico Elektrorygiel Apertura porta elettrica
	Eénpuntsluiting met dagschieter Fermeture à 1 point à pêne 1-Point lock with latch Einfachverriegelung mit Falle	Cerradura 1 punto golpe Zamek 1-punktowy Serratura a 1 punto di chiusura con fermo		Deurgrendels en kantschuiven Verrous de condamnation portes Flush and door bolts Kantenriegel und Türtreibriegel	Pasadores puerta Rygle biernych skrzydel drzwiowych Catenacciolo chiusura centrale
	Eénpuntsluiting met rol Fermeture à 1 points à rouleau 1-Point lock with roller Einfachverriegelung mit Rolle	Cerradura de 1 punto con rodillo Zamek 1-punktowy z barylka Serratura a 1 punto di chiusura con rullino		Geen elektrische spanning bij gesloten deur En cas de porte fermé pas des tension électrique No electric tension in case of closed door Keine elektrische Spannung bei geschlossener Tür	Sin tensión eléctrica en caso de que la puerta esté cerrada Brak elektrycznego napiecia w przypadku zamkniętych drzwi -
	Haakslot Serrure à crochet Hook lock Hakenschluss	Cerradura gancho Zamek hakowy -		Keine elektrische Spannung bei geschlossener Tür	-
	Tweepuntsluiting Fermeture à 2 points 2-Point lock 2-Fachverriegelung	Cerradura de 2 puntos Zamek 2-punktowy Serratura a 2 punti di chiusura		Raampompen Crémones Window handles Handhebel	Cremona Klamka okienna Cremonese
	Driepuntsluiting Fermeture à 3 points 3-Point lock Dreifachverriegelung	Cerradura de 3 puntos Zamek 3-punktowy Serratura a 3 punti di chiusura		Deurkrukken Béquilles Door handles Türdrücker	Manubrios Klamka drzwiowa Maniglie
	Driepuntsluiting met rol Fermeture à 3 points à rouleau 3-Point lock with roller Dreifachverriegelung mit Rolle	Cerradura de 3 puntos con rodillo Zamek 3-punktowy z barylka Serratura a 3 punti di chiusura con rullino		Sluitingen dubbele deur Serrures pour porte double Locks for double door Türtreibriegel	Cerradura puerta doble Blokada drzwi dwuskrzydlowych Serratura porta a 2 ante
	Vierpuntsluiting Fermeture à 4 points 4-Point lock 4-Fachverriegelung	Cerradura de 4 puntos Zamek 4-punktowy Serratura a 4 punti di chiusura		Raampomp naar buiten draaiend raam Crémone fenêtre ouvrant vers l'extérieur Handle outward opening window Handhebel nach aussen öffnendes Fenster	Cremona ventana apertura exterior Klamka okna otwieranego na zewnątrz -
	Vijfpuntsluiting Fermeture à 5 points 5-Point lock Fünffachverriegelung	Cerradura de 5 puntos Zamek 5-punktowy Serratura a 5 punti di chiusura			
	Vijfpuntsluiting met rol Fermeture à 5 points à rouleau 5-Point lock with roller Fünffachverriegelung mit Rolle	Cerradura de 5 puntos con rodillo Zamek 5-punktowy z barylka Serratura a 5 punti di chiusura con rullino		Raamscharnieren Paumelles pour fenêtres Window hinges Fensterbänder	Bisagras ventana Zawias okienny Cerniere
	Zespuntsluiting Fermeture à 6 points 6-Point lock 6-Fachverriegelung	Cerradura de 6 puntos Zamek 6-punktowy Serratura a 6 punti di chiusura		Deurscharnieren 2-delig Paumelles porte 2-partite Door hinges 2-part Türbänder 2-teilig	Pernio puerta 2 palas Zawias drzwiowy 2-czesciowy Cerniera 2 ali
	Zevenpuntsluiting Fermeture à 7 points 7-Point lock Siebenfachverriegelung	Cerradura de 7 puntos Zamek 7-punktowy Serratura a 7 punti di chiusura		Deurscharnieren 3-delig Paumelles porte 3-partite Door hinges 3-part Türbänder 3-teilig	Pernio puerta 3 palas Zawias drzwiowy 3-czesciowy Cerniera 3 ali
	Espagnoletslot Fermeture espagnolette Espagnolette Lock Treibriegelverschluss	Cierre ventana Zamek drzwiowy do blokady pionowej Serratura a spagnoletta		Afstandsbusen Pièces de distance Set of distance bushes Distanzbuchsen	Piezas distanciadoras Tuleje dystansowe Set distanzialli spazzolino
	Cilinders Cylindres Cylinders Zylinder	Bombines Cylindry Cilindri		Geen afstandsbusen nodig Pas de pièces de distance No distance bushes needed Keine Distanzbuchse	No necesario piezas distanciadoras Brak koniecznosci stosowania tuleji dystansowych -
	Cilinderplaten Ecussons Cylinder covers PZ-Rosette	Escudos bombin Osłona wkładki bebenkowej Copertura cilindri		Inbraakwerende kogel Bille anti-vol Anti-burglar ball Einbruchhemmend Kugel	Bola proteccion antirobbo Kulka antywłamaniowa -
	Slotpaden Gâches Receivers Schliessbleche	Gancho Gniazdo rygla zamka Riscontri		Dieveklauw Pene anti-degondage Anti-lift pin Sicherheitsbolzen	Perno antielevador Bolec antywyważeniowy -
	Deursluiters Ferme-porte Door closer Türschliesser	Cierrapuertas Samozamykacz drzwiowy Chiusura porta		Kozjindorpelveer Pivot de frein aerien Overhead closer Obentürschliesser	Muelle aereo Samozamykacz gorny -
				Vloerveer Pivot de frein au sol Floor closer Bodentürschliesser	Muelle pavimento puerta Samozamykacz podlogowy -

	Eindstuk deurvleugel Pièce finale ouvr. porte End piece door vent Endkappe Türflügel	Tapeta hoja puerta Koncówka do skrzydła drzwiowego Terminale anta		Binnenbeglazingsdichting Joint à bourrer Inner glazing gasket Innenverglasungsdichtung	Junta de acristalado interior Uszczelka przyszybowa wewnętrzna Guarnizione del vetro interna
	Eindstukken bodemprofiel Pièces finales profilé de seuil End pieces floor profile Endkappe Schwelle	Piezas terminales perfil suelo Koncówki profilu podłogowego Terminale soglia		Buitenbeglazingsdichting Joint de vitrage extérieur Outer glazing gasket Aussenverglasungsdichtung	Junta de acristalado exterior Uszczelka przyszybowa zewnętrzna Guarnizione del vetro esterna
	Eindstukken Z-T deur Bouchon profilé porte Z-T End pieces Z-T door Endkappe Z-T Tür	Tapetas puerta Z-T Element końcowy Z-T drzwi Terminale profili porte Z e T		Buitenbeglazingsdichting Joint de vitrage extérieur Outer glazing gasket Aussenverglasungsdichtung	Junta de acristalado exterior Uszczelka przyszybowa zewnętrzna Guarnizione del vetro esterna
	Afdichtingen dorpels Profils latéral pour bavettes Sill end pieces Endstück für Wetterschenkel	Tapetas condensacion Koncówki do profili podokiennych Coprifilo terminale		Akoestische dichting Joint acoustique Acoustical seal gasket Flügelanschlagdichtung	Junta acustica Uszczelka akustyczna Guarnizione di isolamento acustico
	Glassteunen Supports cale de vitrage Glazing supports Klotzbrücken	Soportes vidrio Podporka pod przeszklenie Supporti per vetro		Middendichtingen Joints centraux Central gaskets Mitteldichtungen	Junta central Uszczelka centralna Guarnizione centrale
	Afdekkap voor waterafvoersleuven Capuchon écoulement d'eau Weep hole cover Abdeckkappe Entwässerung	Deflector aire Maskownica otworu drenazowego Paratempesta		Aanslagdichting Joint de butée Butt strip Anschlagdichtung	Junta tope Uszczelka dylacyjna Guarnizione di battuta
	Eindstukken stolprofielen Bouchons double ouvrant End parts double casement profile Endkappe Stulpprofil	Tapetas perfil doble hoja Koncówka profilu ruchomego słupka Parte finale di un profilo ad inversione		Dilatatiedichtingen Joints de dilatation Expansion gaskets Dehnungsdichtungen	Junta de dilatacion Uszczelka dylacyjna Guarnizione di espansione
	Koppelstuk Piece de raccordement Connection piece Kupplungsstueck	Pieza de union Element Łaczacy -		Dichting Joint Gasket Dichtung	Junta Uszczelka Guarnizione
	Eindstukken voor stolprofielen Bouchons pièce finale pour profilé double ouvrant End parts for double casement profiles Endkappen für Stulpprofile	Tapeta perfil doble hoja Koncówka profilu ruchomego słupka -		Dichting Joint Gasket Dichtung	Junta Uszczelka Guarnizione
	Afdichtingsstuk Pièce d'étanchéité Sealing piece Abdichtung	-		Afdichtingsstuk Pièce d'étanchéité Sealing piece Abdichtung	Pieza de sellado Element uszczelniający Sigillante
	Afdichting goot Fermeture gouttière End piece gutter Endkappe Rinne	Tapetas canal Koncówka rynny -		Dichting veranda Joint véranda Gasket veranda Dichtung Wintergarten	Junta veranda Uszczelka do werandy -
	Eindstuk Pièce finale End piece Endkappe	Terminal Koncówka Terminale		Borsteldichtingen Joints brosse Brushes Bürstendichtungen	Cepillos Szczotki Spazzole
	Stootplaat Arrêt vitrage toiture Glass panel stop Endstück Verglasung	Tope del panel de vidrio Ogranicznik wypełnienia -		Isolerend vulstuk Pièce de remplissage isolante Insulating filling piece Isolierendes Füllstück	Pieza de relleno aislante Wkładka izolacyjna -
	Veranda type 1 Veranda type 1 Veranda type 1 Veranda Typ 1	Veranda tipo 1 Weranda typu 1 -		Einddichting Joint d'assemblage End gasket Enddichtung	Junta Uszczelka końcowa Guarnizione

	Stolp-kipraam Fenêtre double ouvr.-batt. Double casem.-tilt window Stulpfenster D/DK	Ventana abatible doble hoja Okno rozwierano-uchylne dwuskrzydłowe Finestra a 2 ante ribalta		Paniekdeur Porte de panique Panic door Paniktür	Puerta antipánico Drzwi antypaniczne -
	Draaikip Oscillo-battant Turn and tilt Drehkipp	Oscilobatiente Okno rozwierno-uchylne Anta ribalta		Diversen Divers Miscellaneous Diverse	Diversos Elementy uzupełniające Varie
	Kipdraai Battantes-ouvrantes Tilt and turn Kippdreh	Batiente oscilante Okno uchylno-rozwierane Anta ribalta inversa		Klemstuk Clip Clip Federklemme	Clip Uchwyt Clip
	Draairaam Fenêtre ouvrante Side-hung window Drehfenster	Ventana practicable Okno rozwierane Battente		Nokbevestiging Fixation de la faîtière Fixation of the ridge Firstanschluss	Fijacion del resalte Element mocujący kalenicowy -
	Stolpraam Fenêtre double ouvrant Double casement window Stulp-Flügel Fenster	Ventana doble hoja Okno rozwierane wuskrzydłowe Finestra a 2 ante		Isolatie Isolant Insulation Isolation	Aislamiento Izolacja -
	Valraam Fenêtre à soufflet Bottom hung window Kipp-Fenster	Ventana abatible Okno uchylne Wasistas		Briefenkleppen Entrées de courrier Letter boxes Briefeinwurf	Buzones Skryznka na listy -
	Afstandbedieningen valraam Commandes à distance pour fenêtre à soufflet Remote control for fanlight window Oberlichtbeschlag für Kipp-Flügel	Funcionamiento a distancia para ventana de techo Mechanizm do dystansowego uchylania okien -		Automatische deurichtingen Fermetures automatiques Automatic door latches Automatische Türdichtungen	Cierrapuertas automaticos Drzwiowa automat. opadajaca listwa Dispositivo di chiusura soglia
	-	-		Variant Variante Variant Variante	Variante Wariant Variante
	Buitendraaiend raam Fenêtre ouvrant vers l'extérieur Outside opening window Nach aussen öffnendes Fenster	Ventana apertura exterior Okno otwierane na zewnątrz Finestra ad apertura esterna		Verankeringen Ancrages Fixing lugs Verankerungen	Anclajes Kotwy Ancoraggio
	Uitzetzakraam Châssis à l'Italienne Top-hung window Senk-Klappfenster	Ventana proyectante con compas Okno wychylne na zewnątrz Sporgere con frizioni		Sluitpennen en sluitstukken Rouleaux et gâches Lock pins and lock plates Schliessrollen und Schliessstücke	Bulones y cerraderos Płytki i kolek ryglujacy -
	Tuimel- en taatsraam Châssis pivotant Pivot window Schwingflügel	Ventana pivotante Okno obrotowe -		Goot Gouttière Gutter Rinne	Canal Rynna -
	Vouwdeur (MP) Porte pliante (MP) Folding door (MP) Falttür (MP)	Puerta plegable (MP) Drzwi harmonijkowe (MP) -		Dakvenster Tabatière Attic window Dachfenster	Ventana de techo Okno dachowe Lucernario
	Schuifkip (TF) Coulissant-tombant (TF) Slide and tilt (TF) Schiebekiptür (TF)	Paralela Uchylno-przesuwny -		Kunststof dakbedekking Toiture synthétique Synthetic roofing Kunststoff Dachdeckung	Cubierta en material sintético Wypelnienie poliwęglanem na dachy -
	Schuifraam Fenêtre coulissante Sliding window Schiebefenster	Ventana corredera Okno przesuwne -		Zelfklevende dubbelzijdige tape Bande autocollante 2 faces Self-adhesive double sided tape Selbstklebendes beidseitiges Band	Cinta autoadhesiva de dos caras -
	Parallel opengaand raam Fenêtre ouvrant parallele Parallel opening window Parallelausstellfenster	Ventana proyectante paralela Okno rownoległe wysuwane na zewnątrz Sporgere parallelo		Domotica Domotique Domotics Domotik	Domótica Domotica -
	Kipraam Fenêtre battante Tilt window Kippfenster	Oscilo Okno uchylne -		Profielen met hoge isolatiewaarde Profils avec valeur d'isolation élevée Profiles with high insulation value Profile mit hohem Isolationwert	Perfiles alto aislamiento térmico Profile o wysokiej izolacyjności termicznej -
	Dubbele deur buitendraaiend Porte double ouvrant vers l'ext. Double door outward opening Zweiflügelige Tür aussen öffnend	Puerta doble apertura exterior Drzwi dwuskrzydłowe otw. na zew. -		Wielen Galets Rollers Laufwagen	Ruletas Wozki Carrelli
	Deur binnendraaiend Porte ouvrant vers l'int. Door inward opening Tür nach innen öffnend	Puerta apertura interior Drzwi otw. do wewnątrz Porta apertura interna		Regeltringels Tringles de réglage Adjustment rods Regulierstange	Varilla de ajuste Listwy regulacyjne -
	Deur buitendraaiend Porte ouvrant vers l'ext. Door outward opening Tür aussen öffnend	Puerta apertura exterior Drzwi otw. na zewnątrz Porta apertura esterna		Geleidingsplaat Guide Guide plate Führung	Placa guia Element naprowadzający -

	Gereedschap Outillage Tool Werkzeug	Util Narzędzie Utensile		Hydropneumatische pers Presse hydropneumatique Hydropneumatic press Hydropneumatische Presse	Prensa neumática Prasa hydropneumatyczna -
	Gereedschappen en machines voor ontwatering van kader Outillage et machinerie pour drainage dormant Tools and machinery for draining outer frame Werkzeuge und Maschinen für Entwässerung Blendrahmen	Utiles y maquinaria para el drenaje del marco Narzędzia i maszyny do drenazy ościeżnic Utensili e macchinari per il drenaggio del telaio		Zaagmachine Tronçonneuse Sawing machine Kreissäge	Maquina de corte Pila do ciec przestrzennych Macchina per taglio
	Gereedschappen en machines voor ontwatering van vleugel Outillage et machinerie pour drainage ouvrant Tools and machinery for draining vent Werkzeuge und Maschinen für Entwässerung Flügel	Utiles y maquinaria para el drenaje de la hoja Narzędzia i maszyny do drenazy skrzydeł Utensili e macchinari per il drenaggio dell'anta		Hoekenpers Sertisseuse Crimper Eckverbindungsmaschine	Ensambladora Zaciskarka narozy Cianfrinatrice
	Gereedschappen en machines voor T-verbinding Outillage et machinerie pour jonction-T Tools and machinery for T-brackets Werkzeuge und Maschinen für T-Verbinder	Utiles y maquinaria para topes de unión Narzędzia i maszyny do polaczen teowych Utensili e macchinari per i giunti		Handmatrijs Matrice manuelle Manual punch tool Handstanzwerkzeug	Prensa manual Wykrojnik ręczny Punzonatrice manuale
	Gereedschappen en machines voor kruikuitsparing Outillage et machinerie pour fermeture Tools and machinery for closure Werkzeuge und Maschinen für Beschläge	Utiles y maquinaria para el cierre Narzędzia i maszyny do zamknięcia Utensili e macchinari per le chiusure		Gereedschap voor lijminjectie Outillage pour encollage Tool for injection Werkzeug fuer klebeinjektion	Util para inyeccion Narzędzie do wtrysku kleju Utensile scarico per colla
	Gereedschappen voor T-verbindingen Outillage pour connections-T Tool for T-connections Werkzeug fuer T-Verbindungen	Utiles y maquinaria para topes de unión Narzędzia i maszyny do polaczen teowych Utensili e macchinari per i giunti		Gereedschap voor krukken Outillage pour cremones Tool for handles Werkzeug fuer Handhebel	Util para manetas Narzędzie do klamek Utensile per maniglie
	Gereedschappen voor montage Outillage pour montage Tool for assembly Werkzeug für Montage	Utiles y maquinaria para el cierre Narzędzia i maszyny do zamknięcia Utensili e macchinari per le chiusure		Gereedschap voor sluitlatten Outillage pour tringles Tool for linkbars Werkzeug fuer Schubstange	Util para barras union Narzędzie do listew sterujących okuciami Utensile per barre di collegamento
	Klemblokken Blocs de serrage Clamping blocks Spannbacken	Utiles y maquinaria para el cierre Narzędzia i maszyny do zamknięcia Utensili e macchinari per le chiusure		Gereedschap voor T-verbindingen Outillage pour connections-T Tool for T-connections Werkzeug fuer T-Verbindungen	Util para topes de union Narzędzie do polaczen Teowych Utensile per travesi
	Freessjabloon Calibre de fraisage Stencil plate for milling head Fräseschablone	Utiles y maquinaria para el cierre Narzędzia i maszyny do zamknięcia Utensili e macchinari per le chiusure		Gereedschap voor ontwatering buitenkaders Outillage pour drainage dormants Tool for drainage outer frames Werkzeug fuer Entwässerung Blendrahmen	Util drenaje marco Narzędzie do drenazy ościeżnic Utensile per drenaggio telaio
	Geleide matrijs Matrice guidée Punch tool Stanzwerkzeug	Utiles y maquinaria para el cierre Narzędzia i maszyny do zamknięcia Utensili e macchinari per le chiusure		Gereedschap voor hoekverbinding Outillage pour connection d'equerre Tool for corner connection Werkzeug fuer Eckverbinding	Util union esquina Narzędzie do polaczen narozynych Utensile per connessioni d'angolo
	Handmatig gereedschap Outillage manuel Manual tools Handwerkzeuge	Utiles y maquinaria para el cierre Narzędzia i maszyny do zamknięcia Utensili e macchinari per le chiusure		Gereedschap voor montage Outillage pour montage Tool for assembly Werkzeug für Montage	Util para colocacion Narzędzie do montazu -
	Enkelkopse freesmachine Frais. à copier à une broche Copy router 1 spindle Einspindel-Kopierfräse	Utiles y maquinaria para el cierre Narzędzia i maszyny do zamknięcia Utensili e macchinari per le chiusure		Gereedschap voor deursluiteer Outillage pour fermeture porte Tool for door closer Werkzeug für Türschliesser	Util para cierrapuertas Narzędzie do samozamykacza drzwiowego -
	Freessen- en boormachine Fraiseuse et foreuse Router and drilling machine Fräse- und Bohrgerät	Utiles y maquinaria para el cierre Narzędzia i maszyny do zamknięcia Utensili e macchinari per le chiusure		Gereedschap voor deursluiteer Outillage pour fermeture porte Tool for door closer Werkzeug für Türschliesser	Util para cierrapuertas Narzędzie do samozamykacza drzwiowego -
	Freessen- en boormachine Fraiseuse et foreuse Router and drilling machine Fräse- und Bohrgerät	Utiles y maquinaria para el cierre Narzędzia i maszyny do zamknięcia Utensili e macchinari per le chiusure		Gereedschap voor scharnieren Outillage pour charnières Tool for hinges Werkzeug für Bänder	Util para bisagras Narzędzie do zawiasy -
	Freessen- en boormachine Fraiseuse et foreuse Router and drilling machine Fräse- und Bohrgerät	Utiles y maquinaria para el cierre Narzędzia i maszyny do zamknięcia Utensili e macchinari per le chiusure		Gereedschap voor sloten Outillage pour fermetures Tool for locks Werkzeug für Schlösser	Util para cerraduras Narzędzie do zamka -
	Freessen- en boormachine Fraiseuse et foreuse Router and drilling machine Fräse- und Bohrgerät	Utiles y maquinaria para el cierre Narzędzia i maszyny do zamknięcia Utensili e macchinari per le chiusure		Gereedschap voor wisselprofielen Outillage pour chicanes Tool for sections Werkzeug für Wechselprofile	Util para encuentros centrales Narzędzie do przekrojow -
	Freessen- en boormachine Fraiseuse et foreuse Router and drilling machine Fräse- und Bohrgerät	Utiles y maquinaria para el cierre Narzędzia i maszyny do zamknięcia Utensili e macchinari per le chiusure		Gereedschap voor beglazing Outillage pour vitrage Tool for glazing Werkzeug für Verglasung	Util para acristalamiento Narzędzie do przeszklen -
	Freessen- en boormachine Fraiseuse et foreuse Router and drilling machine Fräse- und Bohrgerät	Utiles y maquinaria para el cierre Narzędzia i maszyny do zamknięcia Utensili e macchinari per le chiusure		Gereedschap voor diverse toepassingen Outillage pour applications divers Tool for miscellaneous applications Werkzeug für diverse Anwendungen	Utiles para varias aplicaciones Narzędzie do montazu elementow uzupełniających -

	Gereedschap voor dichtingen Outillage pour joints Tool for gaskets Werkzeug für Dichtungen	Util para juntas Narzędzie do uszczelki -		Pneumatische aandrijving Propulsion pneumatic Pneumatic drive Pneumatische Antrieb	Destornillador neumatico Pneumatyczny naped -
	Gereedschap voor bevestiging wielen Outillage pour fixation des roulettes Tool for fixation rollers Werkzeug für Befestigung Laufräder	Util para fijación de ruletas Narzędzie do montazu wozkow -		Ponsunit Unité d'étamper Punch unit Stanzeinheit	Punzon Wykrojnik -
	Gereedschap voor ontwatering vleugels Outillage pour drainage ouvrants Tool for drainage vents Werkzeug für Entwässerung Flügel	Util para drenaje hoja Narzędzie do drenazu skrzydla -		Land Pays Country Land	Pais Kraj -
	Uitfrezing voor inbouw bovenspeun in kozijn Fraisage pour encastrement gond supérieur dans la fenêtre Milling for building in upper pivot in window Ausfräsung für Einbau eines oberen Lagers im Rahmen	Fresado para pivotante en marco superior Frez do montazu gornego sworznia w oknie - -		Min. profiellengte Longueur min. de profilé Min. length of profile Min. Profillänge	Longitud mínima del perfil Minimalna dlugosc profilu -
	Uitfrezing voor inbouw vloerspeun in vleugel Fraisage pour encastrement gond inférieur dans l'ouvrant Milling for building in floor pivot in vent Ausfräsung für Einbau eines Bodenlagers im Flügel	Fresado para pivotante en hoja inferior Frez do montazu dolnego sworznia w skrzydle - -		Max. profiellengte Longueur max. de profilé Max. length of profile Max. Profillänge	Longitud máxima del perfil Maksymalna dlugosc profilu -
	Uitfrezing voor inbouw bovenspeun in kozijn Fraisage pour encastrement gond supérieur dans l'ouvrant Milling for building in upper pivot in vent Ausfräsung für Einbau eines oberen Lagers im Flügel	Fresado para pivotante en hoja superior Frez do montazu gornego sworznia w skrzydle - -		Max. profielhoogte Hauteur max. de profilé Max. height of profiles Max. Profilhöhe	Altura máxima del perfil Maksymalna wysokosc profilu -
	Monteertafel Table de montage Assembly bench Montagetisch	Banco de montaje Stol montazowy -		Max. horizontale beweging Movement max. horizontale Max. horizontal movement Max. horizontale Versetzung	Movimiento horizontal máximo Maksymalny ruch poziomy -
	Elektrische aansluiting Fixation électrique Electric connection Elektrischer Anschluss	Conexión eléctrica Polaczenie elektryczne -		Horizontaal hoekbereik Intervalle d'équerre horizontale Horizontal corner range Eckbereich Horizontal	Rango de corte a inglete horizontal Zakres katow poziomych -
	Elektrische aansluiting Fixation électrique Mechanical connection Mechanischer Anschluss	Conexión mecánica Polaczenie mechaniczne -		Verticaal hoekbereik Intervalle d'équerre verticale Vertical corner range Eckbereich Vertikal	Rango de corte a inglete vertical Zakres katow pionowych XXX
	Compressor Compresseur Compressor Kompressor	Compresor Kompresor -		Motor Moteur Motor Antrieb	Motor Silownik napedowy -
	Kogel Dr. Hahn Bille Dr. Hahn Ball Dr. Hahn Kugel Dr. Hahn	Bola Dr. Hahn Kulka Dr. Hahn -		Gewicht Poids Weight Gewichte	Pesos Ciezar -
	Compressor Compresseur Compressor Kompressor	Compresor Kompresor -		Max. toerental Vitesse d'axe max. Max. spindle speed Max. Drehzahl	Velocidad de sierra Maksymalna predkosc obrotowa -

B

Algemene informatie systemen

Généralités séries

General Information System

Allgemeine Information System

VERWERKINGSVOORSCHRIFTEN

I ALGEMEEN

Zie catalogus "1.Algemene informatie" (099.C01E.00 editie 11/2004)

II VERWERKINGSVOORSCHRIFTEN CONCEPT PATIO CP 155 / CP 155-LS

II.1 CONSTRUCTIEVOORSCHRIFTEN

Om blijvend een perfect eindproduct te garanderen, dienen tijdens de verwerking bepaalde regels in acht genomen te worden.

II.1.1 Verspanende bewerkingen

Onder verspanende bewerkingen wordt verstaan: alle mechanische bewerkingen zoals zagen, frezen, boren, ponsen en knippen. Voor gelakte profielen is het essentieel dat de laklagen aan de randen niet loskomen tijdens deze bewerkingen.

Het is daarom van groot belang voor de kwaliteit van de verbindingen dat:

- het verspanende gereedschap geschikt en voldoende scherp is;
- de machines goed afgeregeld zijn (bv. Toerental);
- een regelmatige controle van het gereedschap gebeurt;
- het verspanende gereedschap correct en voldoende gesmeerd wordt: smeerstick Reynalube (art. nr. 086.9191.--) voor zaagbladen, snijmiddel (art. nr. 086.9175.--) voor ponsgereedschap of de door de machineleveranciers voorgeschreven koel- en smeermiddelen;
- de gepaste klemblokken worden gebruikt;
- de aan- en afvoertafel vrij zijn van spanen en verontreinigingen;
- eventuele koeling gebeurt met chemische neutrale producten die de oppervlaktebehandeling niet aantasten.

Positie / klemming van de profielen tijdens het zagen:

De positie van de profielen op de zaagtafel tijdens het verzagen is zeer belangrijk en is de basis om perfecte verstekken te bekomen na montage van schuifelementen.

De grootste druk moet steeds op de "referentiezijde" van de profielen uitgeoefend worden.

De "referentiezijde" moet perfect horizontaal of verticaal op de zaagtafel geplaatst worden.

Klemblokken moeten eventueel gebruikt worden:

- a. om te vermijden dat speling op de profielen de kwaliteit van het verstek zou beïnvloeden;
- b. om te vermijden dat de profielen zouden kantelen op de tafel.

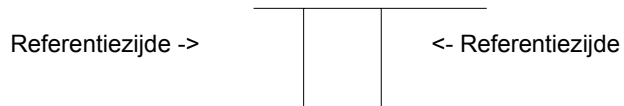

FOUTIEVE KLEMMING

FOUT: De hoofdklemming drukt op de zichtkant van het te verzagen profiel en het profiel kantelt.

GEVOLG: Scheve zaagsnede – de buitenzijde is korter dan de binnenzijde.

RESULTAAT: Bij het persen van de hoeken is het verstek aan de binnenzijde keurig dicht en gaapt aan de buitenzijde.

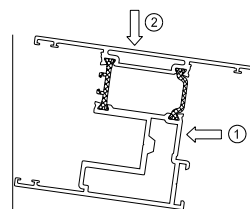

JUISTE KLEMMING

De hoofdklemming drukt op de sponningzijde. De zichtkant ondergaat een kleinere, secundaire druk.

Het profiel heeft niet de neiging te kantelen of te vervormen tijdens het zagen, en het persen van de in verstek gezaagde profielen kan probleemloos verlopen.

Opmerking:

Het verdient aanbeveling om spanen die ontstaan tijdens het zagen af te zuigen.

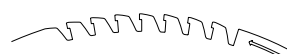
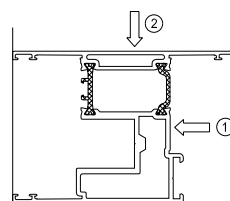
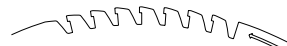

II.1.2

Assemblage

Wij maken de volgende onderverdeling:

1. hoekverbindingen;
2. T-verbindingen en kruisverbinding;
3. ontwatering en uitsparingen voor het beslag;
4. dichtingen.

II.1.2.1 Hoekverbindingen

Stappen:

- a. Correct zagen.
- b. Beschermen van de zaagsneden door:
 - ontbramen (indien noodzakelijk);
 - verwijderen van stof en zaagresten op de zaagsnede en in de profielkamer;
 - ontvetten (Degreaser art. nr. 086.9182.--);
 - aanbrengen van anticorrosieproduct (anticorro art. nr. 086.9610.--): droogtijd: ca. 1 uur.
- c. Afdichten: op de zaagsneden een neutraal, elastisch dichtingmiddel aanbrengen.
- d. Verlijmen: aanbrengen van een goedgekeurd dichtingslijm (tweecomponentenlijm Körapur art. nr. 084.9069.--):
 - in alle profielkamers voor hoekverbinders;
- e. Verbinding tot stand brengen: de hoekstukken kunnen ingebracht worden en vervolgens wordt de mechanische hoekverbinding door persen tot stand gebracht.
- f. De samengevoegde elementen dienen enkel aan de zichtvlakken gereinigd te worden van lijmresten en die uitsluitend met een niet-agressief middel (Reynaclean art. nr. 086.9203.--).

II.1.2.2 T-verbindingen

Stappen:

- a. Correct zagen, frezen, ponsen of boren.
 - b. Beschermen van de zaagsneden door:
 - ontbramen (indien noodzakelijk);
 - verwijderen van stof en zaagresten op de zaagsnede en in de profielkamer;
 - ontvetten (Degreaser art. nr. 086.9182.--);
 - aanbrengen van een anticorrosieproduct (Anticorro art. nr. 086.9610.--); droogtijd: ca. 1uur.
 - c. Afdichten: aanbrengen van een neutraal dichtingmiddel
 - op de zaagsneden;
 - op de bevestigingsgaten;
 - in de zone waar het vleugelprofiel in T-verbinding komt met het vast kader (monorail).
- Opmerking: De zone onder de T-profielen mag niet volledig waterdicht uitgevoerd worden om een gecontroleerde ontwatering van de vleugel te bekomen (zie bladzijde 34.f. ...).
- d. Verbinding tot stand brengen: het T-stuk wordt ingebracht, vastgeschroefd en vernageld.
 - e. De samengevoegde elementen dienen enkel aan de zichtvlakken gereinigd te worden van dichtingresten en dit uitsluitend met een niet-agressief middel (Reynaclean art.nr. 086.9203.-

II.1.2.3 Ontwatering, ontluchting en uitsparingen voor het beslag

Stappen:

- a. Correct ponsen, boren of frezen.
- b. Beschermen van de bewerkte vlakken door:
 - ontbramen (indien noodzakelijk);
 - verwijderen van stof en spanen;
 - ontvetten (Degreaser art. nr. 086.9182.--);
 - aanbrengen van anticorrosieproduct (Anticorro art. nr. 086.9610.--); droogtijd: ca. 1uur.

Aandachtspunten bij de ontwatering / ontluchting:

- Ontwateringseenen die aan de buitenzijde van het schuifelement zichtbaar zijn, worden afgedekt met kunststofkapjes.
- Alle types schuifelementen moeten voorzien zijn van een ontwateringssysteem in de onderregels en / of de horizontale T-profielen. Eventueel binnendringend water moet vlot en gecontroleerd kunnen afgevoerd worden en de druk in de binnenkamers moet gelijk blijven aan die van de buitenlucht.
- Bij elk schuifelement worden er ontwateringopeningen voorzien met een maximale afstand tot de hoek van 250 mm voor de vleugel en 100 mm voor het vast kader. De afstand tussen 2 ontwateringopeningen bedraagt max. 800 mm.
- De minimale oppervlakte bedraagt 50 mm² per opening in de vleugel, hetzij een ronde opening van minimum 8 mm diameter, hetzij langwerpige openingen van minimaal 5 mm bij 15 mm. Voor het vast kader bedraagt de minimale oppervlakte 150 mm² per opening hetzij 3 ronde openingen van min. 8 mm diameter, hetzij een langwerpige opening van minimaal 8 mm bij 34 mm.
- Aan de zijkant bovenaan van de vleugel wordt steeds minstens 1 opening van minimum 5 mm geboord. De functie hiervan is de drukegalisatie rond de beglazing te waarborgen.
- Steeds op het laagste punt van de glassponning afwateren.

Opmerking: Voor specifieke ontwateringen verwijzen wij naar bladzijde 34.f.

II.1.2.4 Dichtingen

Alle dichtingrubbers zijn van weer- en verouderingsbestendig EPDM. De verwerking ervan dient zorgvuldig te gebeuren, aangezien hiervan de dichtheid van het schuifelement afhangt.

a. Het aanbrengen van de beglazingsdichtingen/dichtingen.

Stappen:

1. Correct versnijden: Het versnijden van de beglazingsdichting dient met een speciale schaar (art. nr. 090.0121.00) te gebeuren en de dichting kan naargelang de soort profielverbinding in verstek of recht versneden worden. Benodigde overlengte (ca 10 mm per meter) dient voorzien te worden.
2. Aanbrengen dichting: de dichtingen worden aangebracht in de daarvoor voorziene groeven van de profielen; de overlengte wordt lichtjes opgestuikt om uitzetten of krimpen op te vangen. Moeilijkheden bij het inbrengen kunnen opgevangen worden met siliconenspray (art. nr. 086.9551.--).
3. Verlijmen (afdichten): in de hoeken dient de beglazingsdichting verlijmd te worden met vulkaniseerlijm (Unizionement art. nr. 084.9103.--). Doordat de verbinding elastisch blijft, sluit de dichting ook in de hoeken perfect aan.

b. Het aanbrengen van de borsteldichtingen.

Stappen:

1. Correct versnijden: het versnijden van de borsteldichting dient met een speciale schaar (art. nr. 090.0121.00) te gebeuren en de dichting kan naargelang van de soort profielverbinding in verstek of recht versneden worden.
2. Aanbrengen borsteldichting: de borsteldichtingen worden geschoven in de daarvoor voorziene groeven van de profielen. Moeilijkheden bij het inbrengen kunnen opgevangen worden met siliconenspray (art. nr. 084.9551.--).
3. Verlijmen: Naargelang de soort profielverbinding (recht) dient de borsteldichting aan de uiteinden verlijmd te worden met secondenlijm (Reynaglue art. nr. 084.9105.--). Deze verlijming is noodzakelijk om het uitglijden van de borsteldichting te vermijden.

c. Het aanbrengen van een afdichting onder- en bovenaan het wisselprofiel.

Om een goede water- en winddichtheid te bekomen dient onder- en bovenaan het wisselprofiel een extra afdichting geplaatst te worden:

- 2-rail schuifdeur (CP 155)
 - onder- en bovenaan art. nr. 062.8025.04
- Monorail schuifdeur (CP 155)
 - onder- en bovenaan art. nr. 062.8027.04
- 2-rail hefschuifdeur (CP 155-LS)
 - onderaan art. nr. 062.8011.04
 - bovenaan art. nr. 062.8036.04
- Monorail hefschuifdeur (CP 155-LS)
 - onderaan art. nr. 062.8012.04
 - bovenaan art. nr. 062.8037.04

De afdichting bovenaan moet gemonteerd worden na het inheffen van de vleugels.

II.2 MONTAGEVOORSCHRIFTEN

II.2.1 Inbouw in de ruwbouw

De bevestiging aan de ruwbouw gebeurt ofwel rechtstreeks doorheen de profielen met bijvoorbeeld schroeven en pluggen, ofwel met behulp van bevestigingsankers.

- De bevestigingen mogen niet minder dan 40 mm van de wand van de ruwbouw worden aangebracht.
- De verankering mag geenszins het draagvermogen van de aangrenzende bouwonderdelen beïnvloeden.
- Alle verankeringen, voor zover niet uit aluminium of roestvrij staal, dienen afdoende tegen corrosie te zijn beschermd en mogen zelf ook geen aantasting van het aluminium veroorzaken.
- Bij de plaatsing van de schuifelementen worden er voldoende bevestigingen voorzien:

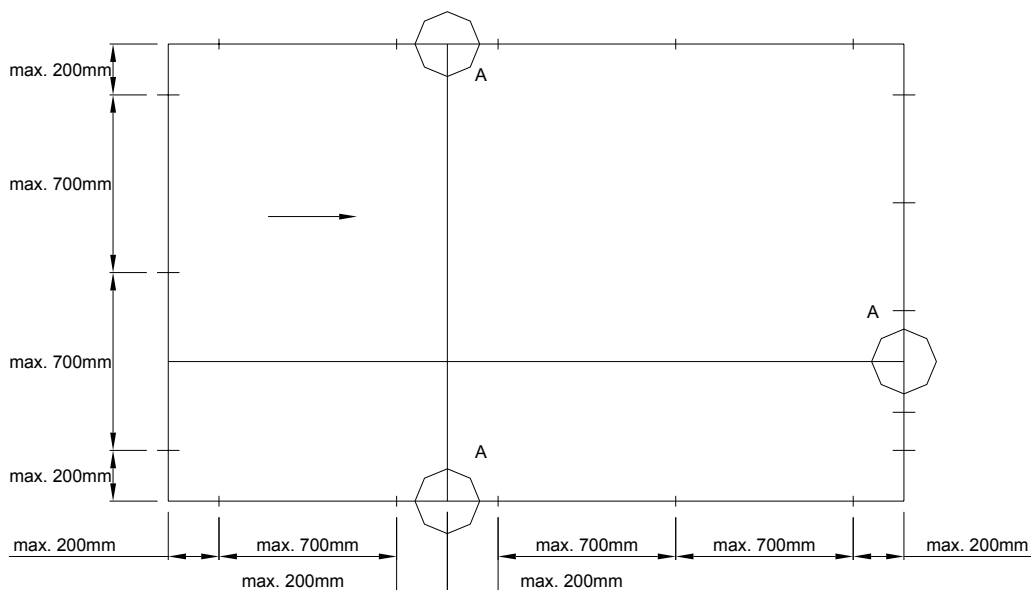

Er dienen aan alle zijden minstens 2 bevestigingen aangebracht te worden met een maximale afstand tot de hoek van 200 mm.

- De afstand van de bevestigingen onderling bedraagt maximum 700 mm.
- Op de plaatsen waar een tussenregel of tussenstijl op de zijstijl, boven- of onderregel aansluit, moet de verankering op maximum 200 mm naast de stijl- of regelaansluiting worden aangebracht. (A).
Hierdoor wordt bereikt dat de tussenregel en de tussenstijl een lengteverandering (ten gevolge van temperatuurverandering) zonder schade kunnen ondergaan.
- Aan te raden is de bevestigingen te positioneren ter hoogte van ieder sluitpunt.

Opmerking: De verankeringen dienen dusdanig aangebracht te worden dat ze eventuele zettingen van het schuifelement kunnen opvangen.

Bij gebruik van schroeven en pluggen doorheen de profielen mogen de kamers in het onderste vast kader niet doorboord worden om geen waterinfiltratie te bekomen ter hoogte van deze bevestiging.

II.2 Inbouw van het beslag

Keuze van bevestigingspunten, aantal sluitpunten, max. Vleugelgewicht, max. Vleugelafmetingen, toegepast vleugelprofiel e.a. dient te gebeuren volgens de richtlijnen van de systeemleverancier en de beslagfabrikant.

Glijdende en bewegende delen zijn van neutraal vet te voorzien.

Bij montage controleren of het beslag soepel en zonder hapering te bedienen is.

II.3 BEGLAZING

Al onze systemen zijn ontworpen voor beglazing met EPDM-rubbers of neutrale siliconenkit. Bij siliconenbeglazing dient een rugvulling aangebracht te worden om een correcte opening tussen het glaspaneel en het aluminiumkader te creëren. Wij raden u aan onze speciaal ontwikkelde beglazingsrubbers te gebruiken. De beglazing hiermee zal vlotter en betrouwbaar verlopen, duurzamer zijn in e tijd, en beschadigde glaspanelen zullen gemakkelijker vervangen kunnen worden.

Bij de beglazing dient rekening te worden gehouden met volgende punten:

- Door opstuiken van de rubber wordt vermeden dat er daarna openingen ontstaan in de hoeken.
- Drainagegaten dienen geboord te worden om waterophoping te vermijden. Dit is ook noodzakelijk bij siliconenbeglazing (zie drainagetekeningen).
- Voor het plaatsen van het glas dient rekening gehouden te worden met een speling van minimum 12 mm op het aluminiumraam (6 mm per zijde).
- De glassteunen die zich aan de onderzijde van het glaspaneel bevinden, dienen afgedicht te worden (zie tekening hieronder).

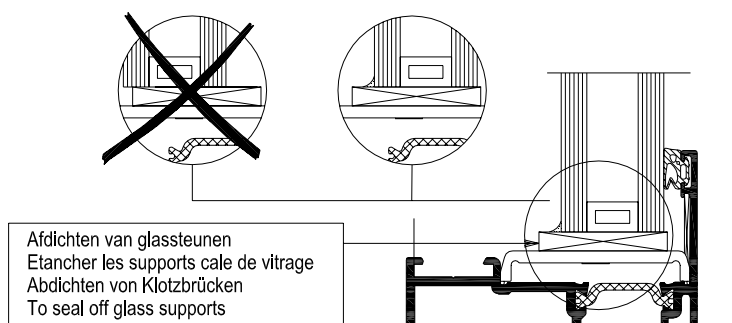

Bevestiging van de beglazing.

Geen enkel glaspaneel mag rechtstreeks in contact komen met aluminium zonder tussenplaatsing van beglazingsblokjes en een rubberdichting.

Door het opspieën van het glas vermijdt men niet enkel dit contact, maar wordt eveneens een juiste plaatsing in het schuifelement bekomen en het eigen gewicht van het glas wordt op de juiste wijze overgebracht naar de wielen teneinde een eventuele vervorming van de vleugel te voorkomen.

In de beglazingsblokjes onderscheiden wij 2 types:

steunblokjes



stelblokjes

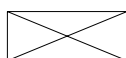

C1: Steunblokjes

Deze blokjes brengen het gewicht van het glas over op de vleugel of het raamkozijn. Hun goede plaatsing is van groot belang voor de werking van de schuifelementen.

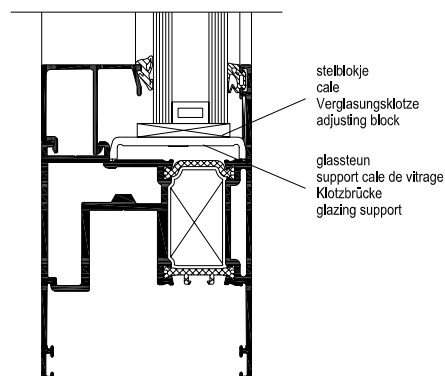

C2: Stelblokjes

Deze blokjes verzekeren de positionering van het glas tussen de sponning. Ze worden aangebracht zonder forceren. Hun doel is elke beweging van het glas in zijn vlak uit te schakelen.

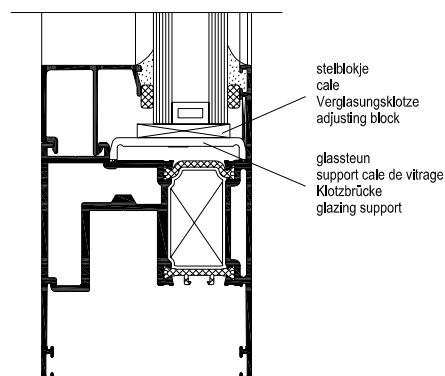

De volgende schetsen geven de plaatsing van de beglazingsblokjes in de verschillende types schuifelementen aan.

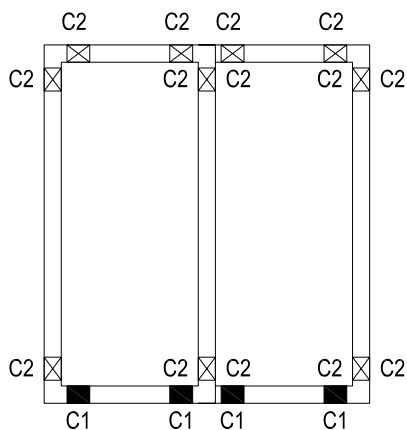

Bij schuivende vleugels dient het glasgewicht overgebracht te worden naar de wielen. De steunblokjes (C1) moeten dus geplaatst worden ter hoogte van de wielen.
Bij vaste vleugels dient het glasgewicht overgebracht te worden naar het steunstuk van de vaste vleugel. De steunblokjes moeten dus geplaatst worden ter hoogte van het steunstuk.

Bij vaste beglazing monorail brengt men de ondersteuning aan in de hoeken van de onderregel om te beletten dat deze gaat doorbuigen onder het gewicht van het glas (zie schets monorail).
Om het vastzetten te vereenvoudigen, beschikken wij over glassteunen die gebruikt worden om de bodem van de sponning te effenen. Hierop kan men dan rechthoekige beglazingsblokjes plaatsen.

RECOMMANDATIONS DE MISE EN OEUVRE

I GENERAL

Voir catalogue "1. Informations générales" (099.C01E.00 édition 11/2004)

II RECOMMANDATIONS DE MISE EN OEUVRE CONCEPT PATIO CP 155 / CP 155-LS

II.1 RECOMMANDATIONS DE FABRICATION

Afin de garantir un produit final parfait, certaines règles doivent être suivies pendant la fabrication.

II.1.1 Opérations d'usinage

Par opérations d'usinage on entend: toutes les opérations mécaniques comme le tronçonnage, le fraisage, le forage, le poinçonnage et la découpe. Il est essentiel que la couche de laque des profils laqués ne se détache pas sur les bords pendant ces opérations.

Il est donc très important pour la qualité des assemblages que:

- Les outils d'usinage soient adaptés et suffisamment aiguisés;
- Les machines soient bien réglées (p.ex. régime);
- Un contrôle régulier des outils ait lieu;
- Les outils d'usinage soient correctement et suffisamment graissés: bâton lubrifiant Reynalube (art. n°. 086.9191.--) pour lames de scie, huile de coupe (art. n°. 086.9175.--) pour outils de poinçonnage ou les réfrigérants et lubrifiants prescrits par les fournisseurs des machines;
- Les mors de serrage adaptés soient utilisés;
- La table d'amenée ou d'évacuation soit exempte de copeaux et de souillures;
- Le refroidissement éventuel se fasse à l'aide de produits chimiquement neutres qui ne corrodent pas le traitement de surface.

Position / serrage des profils pendant le tronçonnage:

La position des profils sur la table de sciage pendant le tronçonnage est très importante et est la base pour obtenir des onglets parfaits après montage des éléments coulissants.

La pression principale doit toujours être exercée sur la "face de référence" des profils..

La "face de référence" doit être positionnée parfaitement horizontalement ou verticalement sur la table de sciage.

Les mors de serrage doivent éventuellement être utilisés:

- a. Pour éviter que les tolérances sur les profils influencent la qualité de l'onglet;
- b. Pour éviter que les profils ne basculent sur la table.

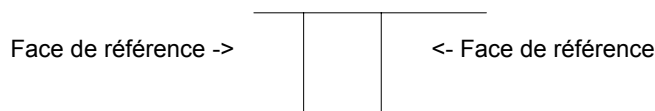

MAUVAIS TRONCONNAGE

DEFAUT: Le vérin principal presse sur la surface visible du profile à tronçonner entraînant son décalage.

CONSEQUENCES: Coupe d'onglet en biais, côtés extérieurs raccourcis par rapport aux côtés intérieurs.

RESULTAT: Après sertissage, l'assemblage sur la face intérieure est correct, tandis qu'à l'extérieur l'onglet s'est ouvert.

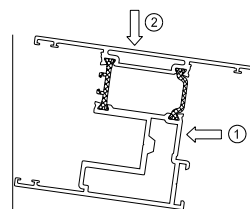

TRONCONNAGE CORRECT

Le vérin principal exerce sa pression sur la face de la feuillure. La surface visible ne subit que la pression réduite du vérin secondaire. Le profilé n'a pas tendance à se décaler ou à se déformer pendant la coupe et le sertissage des profilés sciés à onglet peut s'effectuer sans problèmes.

Remarque:

Il est recommandé d'aspirer les copeaux pendant le tronçonnage.

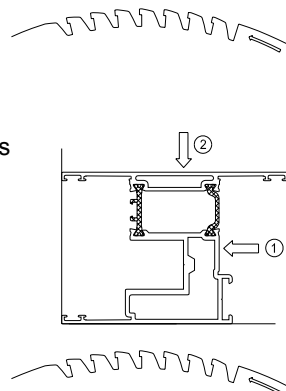

II.1.2

Assemblage

Nous faisons la subdivision suivante:

1. raccords d'angle;
2. assemblages T;
3. drainage, aération et découpes pour les accessoires;
4. joints.

II.1.2.1 Raccords d'angle

Étapes:

- a. Tronçonnage, poinçonnage ou forage correct.
- b. Protection des coupes par:
 - ébavurage (si nécessaire);
 - enlèvement des poussières et des copeaux de sciage sur la coupe et dans la chambre du profilé;
 - dégraissage (Degreaser art. n°. 086.9182.--);
 - application de produit anti-corrosion (Anticorro art. no. 086.9610.--): temps de séchage: environ 1heure.
- c. Étanchement: appliquer sur les coupes de la matière d'étanchéité neutre et élastique.
- d. Encollage: appliquer une colle d'étanchéité approuvée (colle bi composants Körapur art. n°. 084.9069.--):
 - Dans la chambre profilée;
 - Dans la rainure destinée à la cale de feuillure.
- e. Assemblage: les équerres peuvent être introduites et ensuite le raccord d'angle mécanique est réalisé, soit en sertissant, en vissant ou en chevillant.
- f. Sur les éléments composés, les résidus de colle ne doivent être enlevés que des surfaces visibles, et ceci uniquement à l'aide d'un produit non-agressif (Reynaclean art. n°. 086.9203.--).

Remarques:

- En cas d'encollage par injection, les éléments sont d'abord assemblés et l'encollage et l'étanchement se réalisent ensuite.
- Afin d'obtenir une bonne étanchéité du dormant, une fermeture (062.9396.—, 062.9397.--) doit être montée entre le raccord d'angle droit.

II.1.2.2 Assemblage T

Etapas:

- a. Tronçonnage, poinçonnage ou forage correct.
- b. Protection des coupes par:
 - ébavurage (si nécessaire);
 - enlèvement des poussières et des copeaux de sciage sur la coupe et dans la chambre du profilé;
 - dégraisse (Degreaser art. n°. 086.9182.--);
 - application de produit anti-corrosion (Anticorro art. n°. 086.9610.--); temps de séchage: environ 1heure.
- c. Etanchement: appliquer de la matière d'étanchéité neutre:
 - sur les coupes;
 - sur les trous de fixation;
 - dans la zone où le profile est assemblé (assemblage T) avec le dormant (monorail).

Remarque: La zone sous les profiles T ne peut pas être rendue complètement étanche afin d'obtenir un drainage contrôlé de l'ouvrant (voir pages 34.f. ...).

- d. Assemblage: le profilé T est introduit, vissé et chevillé.
- e. Sur les éléments composés, les résidus de matière d'étanchéité ne doivent être enlevés que des surfaces visibles, et ceci uniquement à l'aide d'un produit non-agressif (Reynaclean art.n°. 086.9203.-

II.1.2.3 Drainage, aération et découpes pour les accessoires

Etapas:

- a. Poinçonnage, forage ou fraisage correct.
- b. Protection des surfaces traitées par:
 - ébavurage (si nécessaire);
 - enlèvement des poussières et des copeaux;
 - dégraisse (Degreaser art. n°. 086.9182.--);
 - application produit anti-corrosion (Anticorro art. n°. 086.9610.--); temps de séchage: environ 1heure.

Lors du drainage / aération, il faut prêter attention aux points suivants:

- Les ouvertures de drainage qui sont visibles de l'extérieur de l'élément coulissant doivent recevoir des capuchons en matière synthétique.
- Les éléments coulissants, quel que soit leur type, doivent obligatoirement être drainés au niveau des traverses basses et intermédiaires. Ce drainage doit être conçu pour évacuer les eaux d'infiltration éventuelles vers l'extérieur et maintenir la chambre de décompression à la pression atmosphérique.
- Pour chaque élément coulissant, des ouvertures de drainage sont prévues à une distance maximale de l'angle de 250 mm pour l'ouvrant et de 100 mm pour le dormant. La distance maximale entre 2 ouvertures de drainage est de 800 mm.
- Pour l'ouvrant, la surface minimale de ces ouvertures est de 50 mm² par ouverture, soit sous forme d'une ouverture ronde avec un diamètre minimal de 8 mm, doit sous forme d'une ouverture ovale de 5 mm X 15 mm au minimum.
Pour le dormant, la surface minimale est de 150 mm² par ouverture, soit sous forme de 3 ouvertures rondes avec un diamètre minimal de 8 mm, soit sous forme d'ouverture ovale de 8 mm X 34 mm au minimum.
- Sur le haut du côté de l'ouvrant, on fore toujours au moins 1 ouverture de 5 mm de diamètre au minimum. Sa fonction est de garantir l'égalisation de pression autour de vitrage.
- Pour les ouvrants fixes, le joint extérieur (080.9002.04) doit être interrompu sur une distance de 50 mm.
- Il faut toujours drainer au niveau de point le plus bas de la feuillure de vitrage.

Remarque: Pour des drainages spécifiques, nous nous référons à la page 34.f. ...

II.1.2.4 Joints

Tous les joints sont en EPDM résistant aux intempéries et au vieillissement. Leur montage doit se faire soigneusement, puisque l'étanchéité de l'élément coulissant en dépend.

a. Application des joints de vitrage / joints.

Étapes:

1. Découpe correcte: la découpe du joint de vitrage doit se faire avec des ciseaux spéciaux (art. n°. 090.0121.00) et le joint peut être coupé à onglet ou droit en fonction du type de jonction entre les profilés. Une longueur supplémentaire (environ 10 mm par mètre) doit être prévue.
2. Application du joint: les joints sont appliqués dans les rainures des profils prévues à cet effet; la longueur supplémentaire est légèrement refoulée pour neutraliser la dilatation ou le rétrécissement. Les difficultés de mise en place peuvent être résolues à l'aide d'un aérosol silicone (art. n°. 086.9551.--).
3. Encollage (étanchement): dans les angles, le joint de vitrage doit être encollé avec de la colle de vulcanisation (Unizionement art. n°. 084.9103.--). Cette colle permet à la jonction de rester élastique et de garantir parfaitement le rôle du joint même dans les angles.

b. Application des brosses.

Étapes:

1. Découpe correcte: la découpe de la brosse doit se faire avec des ciseaux spéciaux (art. n°. 090.0121.00) et le joint peut être coupé à onglet ou droit en fonction du type de jonction entre les profilés.
2. Application de la brosse: les brosses sont appliqués dans les rainures des profils prévues à cet effet. Les difficultés de mise en place peuvent être résolues à l'aide d'un aérosol silicone (art. no. 084.9551.--).
3. Encollage: En fonction du type de jonction entre les profils (droit), la brosse doit être encollée aux extrémités avec de la colle rapide (Reynaglué art. n°. 084.9105.--). Cet encollage est nécessaire pour éviter le glissement de la brosse.

c. Application d'une fermeture en bas et en haut de la chicane.

Afin d'obtenir une bonne étanchéité à l'eau et au vent, une fermeture supplémentaire doit être montée en bas et en haut de la chicane:

- 2-rail porte coulissante (CP 155)
 - en bas et en haut art. no. 062.8025.04
- Monorail porte coulissante (CP 155)
 - en bas et en haut art. no. 062.8027.04
- 2-rail porte levant-coulissante (CP 155-LS)
 - en bas art. no. 062.8011.04
 - en haut art. no. 062.8036.04
- Monorail porte levante-coulissante (CP 155-LS)
 - en bas art. no. 062.8012.04
 - en haut art. no. 062.8037.04

La fermeture en haut doit être appliquée après le montage des ouvrants.

II.2 RECOMMANDATIONS DE MONTAGE

II.2.1 Montage dans le gros œuvre

La fixation au gros œuvre se fait soit directement à travers les profils avec par exemple des vis et des chevilles, soit à l'aide d'ancrages de fixation.

- Les fixations ne peuvent pas être appliquées à une distance inférieure à 40 mm du mur du gros œuvre..
- L'ancrage ne peut surtout pas influencer la force portante des éléments de construction contigus.
- Tous les ancrages, pour autant qu'ils ne soient pas en aluminium ou en acier inoxydable, doivent être efficacement protégés contre la corrosion et ne peuvent pas corroder l'aluminium.
- Lors de la pose des éléments coulissants, on prévoit des fixations en suffisance:

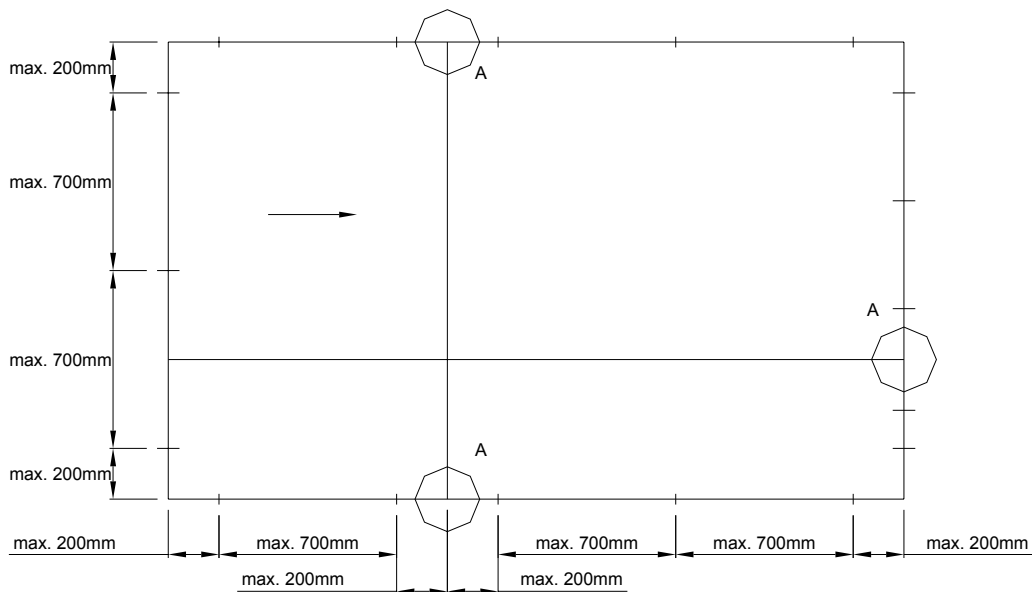

De tous les côtés il doit y avoir au moins 2 fixations avec une distance maximale jusqu'à l'angle de 200 mm.

- La distance entre les fixations est de 700 mm au maximum.
- A l'endroit où des profils T et des profils dormants se rencontrent, l'ancrage doit être appliqué à une distance maximale de 200 mm des deux côtés de profile T (A).
De cette façon, une dilatation ou un rétrécissement du profile T (dus aux fluctuations de température) sont possibles sans dégâts.
- Il est conseillé de positionner les fixations à la hauteur de chaque point de fermeture.

Remarque: Les ancrages doivent être appliqués d'une telle façon qu'ils peuvent neutraliser des dilatations / rétrécissements éventuels de l'élément coulissant.

Si des vis et des chevilles sont utilisées à travers les profils, les Chambers dans le dormant inférieur ne peuvent pas être percées afin d'éviter de l'infiltration d'eau à la hauteur de cette fixation.

II.2.2 Montage des accessoires

Le choix des points de fixation, du nombre de points de fermeture, du poids max. D'ouvrant, des dimensions max. d'ouvrant, du profile ouvrant appliqué, etc. doit se faire suivant les introductions du fournisseur des systèmes et du fabricant des accessoires.

Les parties coulissantes et mobiles doivent être pourvues de graisse neutre.

Lors du montage, il faut contrôler si les accessoires peuvent être actionnés de façon souple et sans bloquer.

II.3 VITRAGE

Tous nos systèmes sont conçus pour vitrer à l'aide de joints d'EPDM ou de silicone neutre. En cas d'utilisation d'un joint en silicone, l'usage d'un fond de joint constitué d'un joint-mousse compressible autocollant est recommandé pour maintenir un espace libre suffisant entre le verre et l'aluminium. Nous vous recommandons d'utiliser notre système de joints de vitrage pour des raisons de facilité et fiabilité de mise en œuvre, de bonne tenue dans le temps et de simplicité dans le remplacement de volumes verriers.

Le vitrage devra se faire en respectant les points suivants:

- Le joint doit être refoulé pour éviter qu'apparaissent, dans le temps, des ouvertures dans les angles dues au rétrécissement de ce joint.
- Des ouvertures de drainage doivent être forées afin d'éviter toute stagnation d'eau. Ceci est également nécessaire en cas de vitrage en silicone (voir schémas de drainage).
- Pour la pose des vitrages, le jeu entre vitrage et fond de feuillure doit être de 12 mm (6mm par côté) au minimum.
- Les supports de vitrage qui se trouvent en dessous du panneau de vitrage doivent être rendus étanches (voir dessin ci-après).

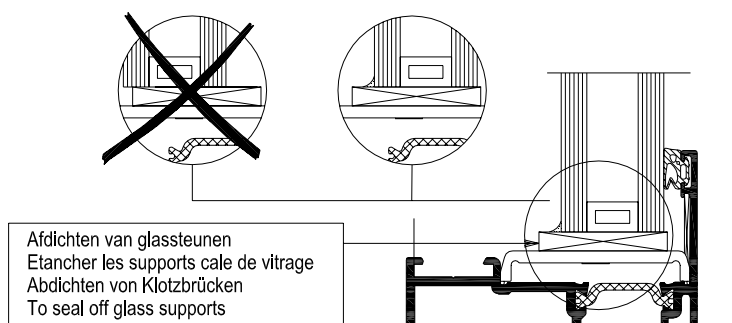

Fixation du vitrage.

Aucun volume verrier ne peut être directement en contact avec l'aluminium. La pose de cales de vitrage et d'un joint est indispensable.

Le but du calage du verre est non seulement d'éviter ce contact, mais également d'obtenir une bonne pose dans l'élément coulissant et de transmettre de façon correcte le poids du verre même sur les galets afin de prévenir une déformation éventuelle de l'ouvrant.

Nous distinguons 2 types de cales de vitrage:

cale de support



cale d'ajustement

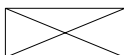

C1: Cales de support

Ces cales transmettent le poids du verre sur l'ouvrant ou sur l'allège, et leur bonne pose est d'une importance capitale pour le fonctionnement des éléments coulissants.

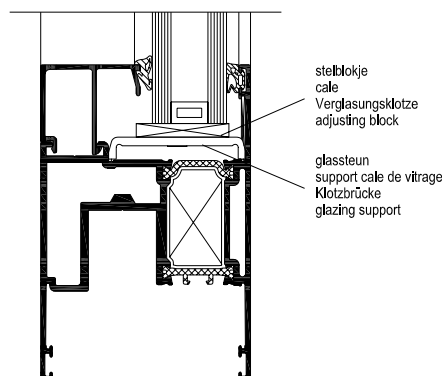

C2: Cales d'ajustement

Ces cales assurent le positionnement du verre par rapport à la feuillure, et sont appliqués sans forcer. Elles empêchent tout mouvement du verre dans son logement.

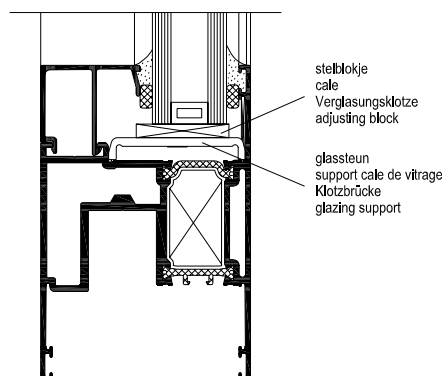

Les schémas suivants indiquent la pose des différentes cales de vitrage dans les différents types d'éléments coulissants.

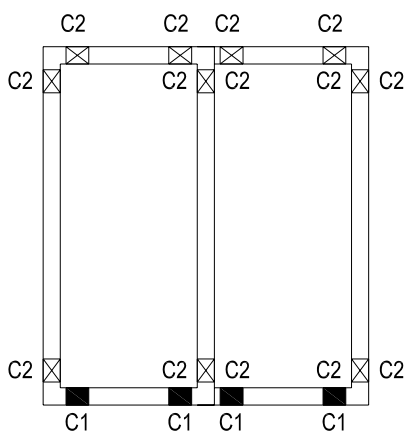

Le poids de vitrage des ouvrants coulissants doit être transmis sur les galets. Les cales de support (C1) doivent donc être montées à la hauteur des galets.

Le poids de vitrage des ouvrants fixes doit être transmis sur la pièce de support de l'ouvrant fixe. Les cales de support (C1) doivent donc être montées à la hauteur de la pièce de support.

En cas de vitrage fixe monorail, on applique les supports dans les angles de la traverse basse pour empêcher que celle-ci ne plie sous le poids du verre (voir schéma monorail).

Afin de simplifier le calage du vitrage, nous disposons de supports de vitrage qui sont utilisés pour égaliser le fond de la feuillure. Sur ces supports on peut utiliser des cales de vitrage rectangulaires.

PROCESSING DATA

I GENERAL

See catalogue "1.General information" (099.C01E.00 edition 11/2004)

II PROCESSING DATA CONCEPT PATIO CP 155 / CP 155-LS

II.1 FABRICATING PRESCRIPTIONS

In order to guarantee a perfect end product, the following guidelines should be adhered to during the production process.

II.1.1 Metal-removing operations

Metal-removing operations are understood to mean all mechanical operations such as sawing, milling, drilling, punching and cutting. For painted profiles it is essential that the paint coatings do not come off on the edges during these operations.

Therefore it is very important for the quality of the connections that:

- the metal-removing tools are appropriate and sufficiently sharp;
- the machines are well adjusted (e.g. number of revolutions);
- the tools are regularly checked;
- The metal-removing tools are greased sufficiently and correctly: Reynalube cutting grease block (art. nr. 086.9191.--) for saw blades, cutting spray (art. nr. 086.9175.--) for punch tools or the cooling agents and lubricants prescribed by the machine suppliers;
- the appropriate clamp blocks are used;
- the cutting table is free of swarf and dust;
- Possible cooling is done by means of chemically neutral products which do not attack the surface treatment.

Position / clamping of the profiles during cutting:

The position of the profiles on the sawing table during cutting is very important and is the basis to get perfect miters after assembly of the sliding elements.

The biggest clamping pressure should always be on the "reference side" of the profiles.

The "reference side" has to be perfectly horizontally and vertically on the sawing table.

The clamp blocks should possibly be used:

- a. to ensure that tolerances on the profiles do not influence the quality of the mitre;
- b. To ensure that the profiles do not twist on the table.

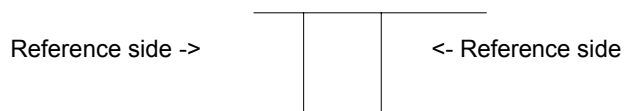

INCORRECT CLAMPING

FAULT: The clamping pressure is on the upper side of the profile, allowing it to twist during cutting.

CONSEQUENCE: An oblique saw cut resulting in the outside of the profile being shorter than the inside.

RESULT: On assembly, the corner is closed on the inside and open on the outside.

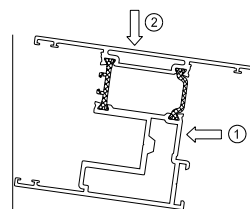

CORRECT CLAMPING

Here, the clamping pressure is on the rebate side of the profile, and the visible side undergoes a smaller secondary pressure.

The profile is prevented from twisting or deforming during cutting. A perfect joint is obtained on assembly.

Remark:

It is recommended to exhaust the swarf during the cutting.

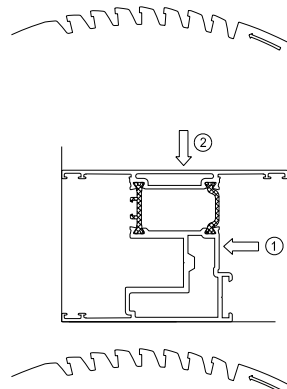

II.1.2

Assembly

We make the following subdivisions:

1. Corner connections;
2. T-brackets;
3. Drainage, aeration and recesses for the accessories;
4. Gaskets.

II.1.2.1 Corner connections

Steps:

- a. Correct sawing, punching or drilling.
- b. Protection of the saw cuts by:
 - deburring (if necessary);
 - removing dust and saw-dust on the saw cut in the profile chamber;
 - Degreasing (Degreaser art. no. 086.9182.--);
 - Applying anti-corrosion product (Anticorro art. no. 086.9610.--): drying time: about 1hour.
- c. Sealing: applying a neutral elastic agent on the saw cuts.
- d. Gluing: applying approved sealing glue (glue for corner connection Körapur art. no. 084.9069.--):
 - Apply sealing glue in the profile chamber;
 - Also glue the rebate support.
- e. Making the connection: the corner cleats can be inserted and the mechanical corner connection can be made, either by crimping or by screwing / driving-in pins.
- f. The adhesive residue on the visible sides of the completed elements has to be removed by means of a non-aggressive product (Reynaclean art. nr. 086.9203.--).

Remarks:

- In case of glue injection, the elements are first combined and glued / sealed afterwards.
- To obtain a good sealing of the outer frame a closer (062.9396.—062.9397.--) should be fitted between the straight corner connection.

II.1.2.2 T-brackets

Steps:

- a. Correct sawing, milling, punching or drilling.
 - b. Protection of the saw cuts by:
 - deburring (if necessary);
 - removing dust and saw-dust on the saw cut and in the profile chamber;
 - Degreasing (Degreaser art. no 086.9182.--);
 - Applying anti-corrosion product (Anticorro art. no. 086.9610.--); drying time: about 1hour.
 - c. Sealing: applying a neutral sealing agent:
 - on the saw cuts;
 - on the fixing holes;
 - In the area where the panel profile is connected (T-bracket) with the outer frame (monorail).
- Remark: The area under the transom/mullions may not be completely watertight in order to obtain a controlled drainage of the sliding panel (see pages 34.f. ...).
- d. Making the connection: the T-bracket is inserted, screwed and fixed with driving-in pins.
 - e. The sealing agent residue on the visible sides of the completed elements has to be removed by means of a non-aggressive product (Reynaclean art.no. 086.9203.-

II.1.2.3 Drainage and recesses for the accessories

Steps:

- a. Correct punching, drilling or milling.
- b. Protection of the treated surfaces by:
 - deburring (if necessary);
 - removing dust and saw-dust;
 - Degreasing (Degreaser art. no. 086.9182.--);
 - Applying anti-corrosion product (Anticorro art. no. 086.9610.--); drying time: about 1hour.

Special attentions should be paid to the following regarding drainage / aeration:

- Drainage holes which are visible on the outside of the sliding element are covered with drainage covers in synthetic material.
- All types of sliding elements should be provided with a drainage system in the bottom profiles or the transoms. This is to allow infiltrating water to escape outside and also ensures that the profile's chambers remain at atmospheric pressure.
- For all sliding elements, drainage holes should be a maximum of 250 mm from the corner for the sliding panel and 100 mm for the outer frame. The maximum distance between 2 drainage holes is 800 mm.
- The minimum surface of these openings is 50 mm² per opening in the sliding panel, either a round opening of minimum 8 mm diameter, or elongated openings of minimum 5 mm by 15 mm. For the outer frame the minimum surface is 150 mm² per opening, either 3 round openings of minimum 8 mm diameter, or an elongated opening of minimum 8 mm by 34 mm.
- On the side at the top of the sliding panel at least 1 opening of minimum 5 mm should always be drilled. Its function is to guarantee the pressure equalization around the glazing. For fixed panels the outer gasket (080.9002.04) should be interrupted over a distance of 50 mm.
- Always drain at the lowest point of the glass rebate.

Remark: For specific drainage we refer to pages 34.f. ...

II.1.2.4 Gaskets

All gaskets are of EPDM resistant to weathering and ageing. They should be carefully applied since the tight sealing of the sliding elements depends on their correct application.

a. Applying the glazing gaskets/gaskets.

Steps:

1. Correct cutting: the glazing gasket should be cut with special gasket shears (art. no. 090.0121.00) and can be cut straight or mitred according to the kind of profile connection. Extra overhanging (about 10 mm per meter) is required.
2. Application of the gasket: the gaskets are applied in the appropriate grooves within the profiles; they should be cut slightly longer than is necessary to compensate for any shrinkage that may occur. Difficulties in applying the gasket can be solved by the use of silicone spray (art. no. 086.9551.--).
3. Gluing (sealing): in the corners, glazing gaskets should be glued with vulcanizing agent (Unizionement art. no. 084.9103.--). This vulcanizing agent will remain elastic and because of this the gasket will also fit perfectly into the corners.

b. Applying the brushes.

Steps:

1. Correct cutting: the brush should be cut with special gasket shears (art. no. 090.0121.00) and can be cut straight or mitred according to the kind of profile connection.
2. Application of the brush: the brushes are applied in the appropriate grooves within the profiles. Difficulties in applying the brush can be solved by the use of silicone spray (art. no. 084.9551.--).
3. Gluing: In function of the type of profile connection (straight), the brush should be glued at the ends with contact glue (Reynaglue art. no. 084.9105.--). This gluing is necessary to avoid the slipping away of the brush.

c. Applying a closer at the bottom and the top of the meeting section.

To obtain a good water tightness, an extra closer should be fitted at the bottom and top of the meeting section:

- 2-rail sliding door (CP 155)
 - At bottom and top art. no. 062.8025.04
- Monorail sliding door (CP 155)
 - At bottom and top art. no. 062.8027.04
- 2-rail lift & slide door (CP 155-LS)
 - At bottom art. no. 062.8011.04
 - At top art. no. 062.8036.04
- Monorail lift & slide door (CP 155-LS)
 - At bottom art. no. 062.8012.04
 - At top art. no. 062.8037.04

The closer at the top has to fit after the panels have been fitted.

II.2 FITTING

II.2.1 Fitting in the structural work

The fixing to the structural work is done either directly through the profiles by means of for instance screws and plugs, or by means of fixing lugs.

- The fixings may not be applied less than 40 mm of the wall of the structural work.
- The anchoring may in no way influence the bearing power of the adjacent building parts.
- All anchorings, as far as they are not made of Aluminium or stainless steel, should be adequately corrosion-protected and may not attack the Aluminium themselves.
- When fitting the sliding elements, sufficient fixings are required:

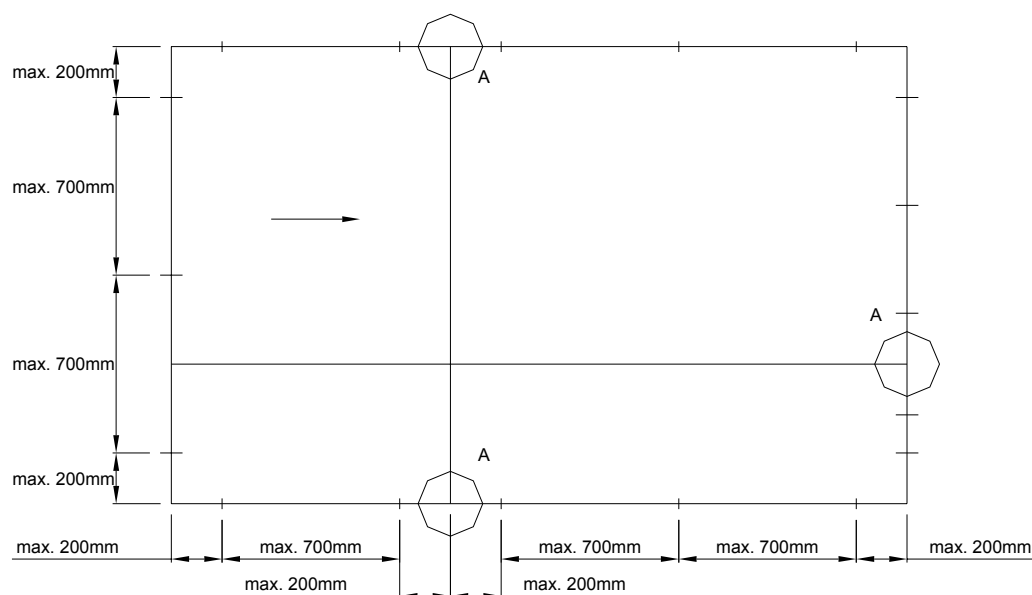

At least two fixings should be applied on all sides; the maximum distance to the corner is at least 200 mm.

- The distance between the fixings is maximum 700 mm.
- Where transom/mullions and outer frame profiles meet, the fixing must be applied maximum 200 mm from both sides of the transom/mullion (A).
In this way, expansion and shrinkage of the transom/mullion (because of fluctuations of temperature) are possible without any damage.
- We recommend to position the fixings at the height of each locking point.

Remark: The anchoring should be applied in such a way that possible expansion / shrinkage of the sliding element is not obstructed.

When screws and plugs are used directly through the profiles, the chambers in the bottom outer frame may not be pierced to avoid water infiltration at the height of this fixing.

II.2 Fitting of the accessories

The choice of the fixing points, number of locking points, max. Weight of the sliding panel, max. Sizes of the sliding panel, panel profile used etc. depends on the instructions of the system supplier and the accessory producer.

Sliding and moving parts should be provided with neutral grease.

When fitting, please check whether all accessories can be operated easily and without getting stuck.

II.3 GLAZING

Reynaers' systems are designed for EPDM gasket or neutral silicone glazing. In case of silicone glazing a backing rod should be applied to create a correct opening between the glass panel and the Aluminium frame. For easy and reliable fitting, durability and reglazing simplicity, we recommend using only Reynaers' gaskets – specially adapted for our profiles.

The following precautions should be taken when fitting the glazing:

- Cut the glazing gaskets slightly longer than is necessary to avoid openings in the corners at a later stage.
- Drainage holes should be drilled to avoid build-up moisture. This is also necessary in the case of silicone glazing (see drainage drawings).
- Glass panels should be at least 12 mm (6 mm per side) smaller than the actual measured glazing size.
- The glass supports on the bottom of the glass panel should be sealed (see drawing below).

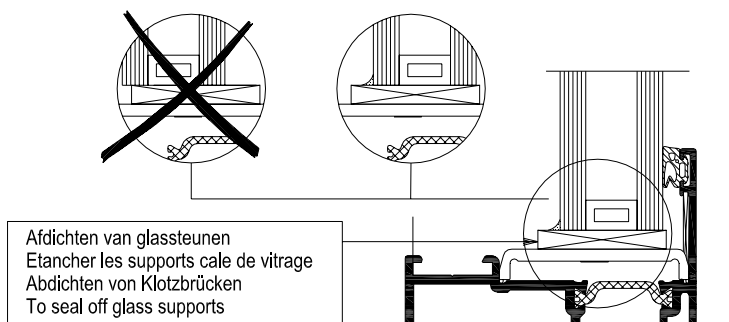

Fitting glass panels.

Glass panels should not come into contact with the Aluminium frame; always use glazing blocks and gaskets.

Wedging prevents this contact and also ensures correct positioning of the glass in the frame, distributing the weight equally onto the rollers to avoid deformation.

There are 2 types of glazing blocks:

support block



adjusting block



C1: Support blocks

These blocks distribute the weight of the glass onto the sliding panel or the outer frame. Correct positioning is very important for the sliding panel to function correctly.

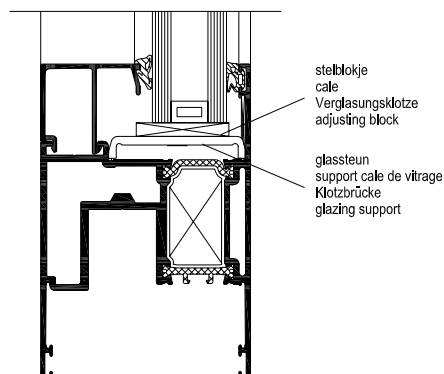

C2: Adjusting blocks

These blocks guarantee the correct positioning of the glass between the rebates. They must be positioned without twisting or damaging the profile. Adjusting blocks also prevent the glass panels from moving.

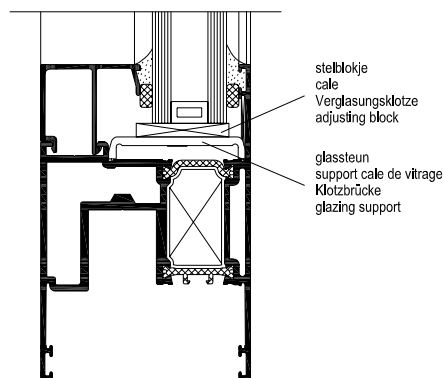

The following sketches indicate the different glazing blocks in different types of sliding elements.

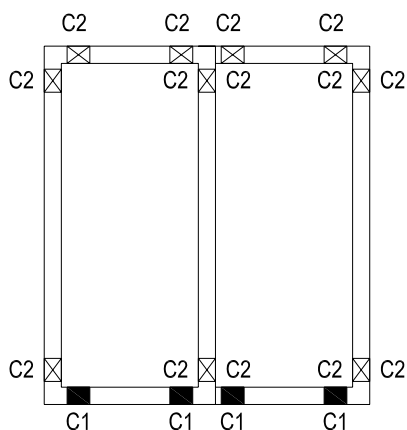

The glass weight of sliding panels should be distributed equally onto the rollers. The support blocks (C1) should consequently be fitted at the height of the rollers.

The glass weight of fixed panels should be distributed onto the support piece of the fixed panel. The support blocks (C1) should consequently be fitted at the height of the support piece.

In fixed glazing monorail, supports are fitted in the corners of the bottom profile to avoid bending due to the weight of the glass (see sketch monorail).

For ease of fitting, we have special glass supports which can be used to equalize the rebate. The rectangular glazing blocks can be placed on these.

VERARBEITUNGSVORSCHRIFTEN

I ALLGEMEIN

Siehe Katalog "1. Allgemeine Information (099.C01E.00 Ausgabe 11/2004)

II VERARBEITUNGSVORSCHRIFTEN CONCEPT PATIO CP 155 / CP 155-LS

II.1 VERARBEITUNG

Um ein qualitativ hochwertiges Endprodukt zu erstellen, sollen bei der Verarbeitung folgende Punkte berücksichtigt werden:

II.1.1 Spanende Bearbeitungen

Mit ‚spanenden Bearbeitungen‘ sind alle mechanischen Bearbeitungen, wie Sägen, Fräsen, Bohren, Stanzen gemeint.

Bei allen mechanischen Bearbeitungen ist auf den Einsatz geeigneter Sägeblätter, Fräser und Bohrer zu achten, damit die Oberfläche nicht durch Grate oder abplatzende Beschichtung beschädigt wird.

Zur Profilbearbeitung geben wir folgende Hinweise:

- Die spanabhebenden Werkzeuge müssen für den Werkstoff geeignet und ausreichend scharf sein;
- Die Maschinendrehzahl muss auf den Werkstoff Aluminium abgestimmt sein;
- Die Profilaufgaben müssen sauber und spanfrei sein;
- Zur Verlängerung der Werkzeugstandzeiten können geeignete Gleitmittel, wie der Fettstift Reynalube (Art. Nr. 086.9191.--), das Reynaers-Schneidmittel (Art. Nr. 086.9175.--) oder die von den Maschinenlieferanten vorgeschriebenen Kühl- und Schneidmittel eingesetzt werden. Diese Kühl- und Schneidmittel müssen chemisch neutrale Produkte sein, die die Oberfläche nicht angreifen.

Zuschnitt:

Der Auflage-/Säge-Tisch sollte eine glatte und ebene Auflagefläche bieten. Der dahinterliegende Anschlag sollte exakt im Winkel von 90° positioniert sein. Auf dem Maschinentisch sollen keine Verunreinigungen, wie Sägespäne oder Kleberreste vorhanden sein. Eine Fixierung der Profile erfolgt mittels Hand- oder pneumatischer Spannzylinder, welche von oben und von vorne auf das Profil wirken.

Ein Verdrehen der Profile während des Sägevorganges ist durch den Einsatz von Schneidzulagen zu verhindern.

Bezugsseite ->

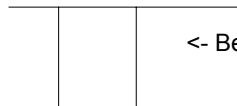

<- Bezugsseite

FALSCH EINSpanNUNG

FEHLER: Da der Hauptdruck der Spannvorrichtung auf die Falzseite des zu sägenden Profils einwirkt, verdreht sich das Werkstück.

FOLGE: Schiefer Sägeschnitt. Die Außenseite des Profils ist länger als die Innenseite.

ERGEBNIS: Beim Verpressen der Profile ist die Gehrung an der Innenseite dicht, steht aber an der Außenseite offen.

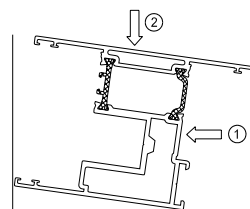

RICHTIGES SPANNEN

Der Hauptdruck der Spannvorrichtung wirkt ein auf die gesamte Fläche. Die Falzseite wird durch eine zweite Spannvorrichtung mit geringerer Kraft gehalten.

Durch diese korrekte Einspannung kann sich das Profil beim Sägevorgang nicht verdrehen.

Die Gehrung wird in der Eckverbindermaschine in der gleichen Art und Weise fixiert, so dass eine exakte Verbindung erreicht wird.

Anmerkung:

Es empfiehlt sich die Späne während des Sägevorganges abzusaugen.

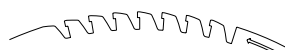
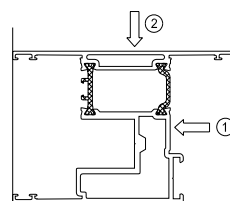
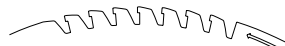

II.1.2

Profilverbindungen und deren Verarbeitung

In den Reynaers-Katalogen wird nach 4 Verarbeitungsschritten unterschieden:

1. Eckverbindungen;
2. T-Verbinder;
3. Entwässerung, Entlüftung und Vorbereitung für den Beschlageinbau;
4. Dichtungen.

II.1.2.1 Eckverbindungen

Verfahrensweise:

- a. Zuschneiden, stanzen oder bohren.
- b. Schutz der Schnittkanten:
 - Entgräten (falls erforderlich);
 - Schnittfläche und Profilkammern von Staub und Sägeresten säubern;
 - Entfetten der Profile (Degreaser Art. Nr. 086.9182.--);
 - Korrosionsschutzprodukt (Anticorro Art. Nr. 086.9610.--): aufbringen; Trockenzeit: ca. 1 Stunde.
- c. Abdichtung: die Schnittflächen mit einer neutralen Dichtungsmasse versehen.
- d. Klebereinsatz: Zweikomponentenkleber (z.B. Körapur Art. Nr. 084.9069.--) einbringen:
 - in die Eckwinkelkammer;
 - im Bereich der Glasanschlagwinkel.
- e. Verbinden: die Verbindung der Profilstücke kann durch verpressen, versinken, verstiften oder verschrauben der Eckwinkel vorgenommen werden.
- f. Ausgetretener Kleber oder Dichtungsmittelreste müssen von den Sichtseiten entfernt werden (Reynaclean Art. Nr. 086.9203.--).

Bemerkungen:

- Es besteht die Möglichkeit die Eckverbindung erst mechanisch und dann den Kleber nachträglich in den Eckwinkelbereich einzubringen.
- Für eine gute Wasserdichtheit des Blendrahmens soll zwischen der geraden Eckverbindung eine Abdichtung (062.9396.—062.9397.--) eingesetzt werden.

II.1.2.2 T-Verbinder

Verfahrensweise:

- a. Zuschneiden, fräsen, stanzen oder bohren.
- b. Schutz der Schnittkanten:
 - Entgräten (falls erforderlich);
 - Schnittfläche und Profilkammern von Staub und Sägeresten säubern;
 - Entfetten der Profile (Degreaser Art. Nr. 086.9182.--);
 - Korrosionsschutzprodukt (Anticorro Art. Nr. 086.9610.--); aufbringen; Trockenzeit: ca. 1 Stunde.
- c. Abdichtung: der Bereich der Befestigungsmittel ist durch den Einsatz geeigneter Dichtungsmittel wasserdicht auszuführen, ebenso wie der Bereich wo das Flügelprofil mit dem Blendrahmen in T-Verbindung kommt (monorail).
Bemerkung Der Bereich im T-Stoss darf nicht völlig wasserdicht sein um eine kontrollierte Entwässerung des Flügels zu bekommen (Siehe Seite 34.f. ...).
- d. Verbinden: nach dem Einbringen des T-Verbinders, der Kleber und Dichtungsmittel, werden die Bauteile zusammengefügt, verstiftet bzw. verschraubt.
- e. Nach dem Zusammenfügen müssen überschüssige Dichtungsmittelreste entfernt werden (Reynaclean Art. Nr. 086.9203.--).

II.1.2.3 Entwässerung und Bearbeitung für den Beschlageinbau

Verfahrensweise:

- a. Stanzen, bohren oder fräsen.
- b. Schutz der Schnittkanten:
 - Entgräten (falls erforderlich);
 - Schnittfläche und Profilkammern von Staub und Sägeresten säubern;
 - Entfetten der Profile (Degreaser Art. Nr. 086.9182.--);
 - Korrosionsschutzprodukt (Anticorro Art. Nr. 086.9610.--); .—) aufbringen; Trockenzeit: ca. 1 Stunde.

Insbesondere ist auf folgendes zu achten:

- Alle sichtbaren Entwässerungsöffnungen müssen mit systemabhängigen Kunststoff-Abdeckkappen versehen werden.
- Alle Schiebeelemente müssen im Solbankbereich bzw. an den horizontalen T-Profilen mit entsprechenden Ausnehmungen versehen werden.
- Eventuell eingedrungenes Wasser muss problemlos und kontrolliert abgeleitet werden können.
- Es sind entsprechende Dampfdruckausgleichsbohrungen vorzunehmen

Bei jedem Schiebeelement sind Entwässerungsbohrungen vorzunehmen. Diese sitzen max. 250 mm aus der Ecke für den Flügel und 100 mm für den Blendrahmen. Der Abstand zwischen 2 Entwässerungsöffnungen betragen max. 800 mm.

Die Mindestoberfläche der Entwässerungsöffnung beträgt 50 mm² pro Öffnung im Flügel, wobei eine Bohrung von mind. 8 mm Durchmesser oder zwei Schlitz von 5 x 15 mm vorzusehen ist. Für den Blendrahmen beträgt die Mindestoberfläche pro Öffnung 150 mm², wobei 3 Bohrungen von mind. 8 mm Durchmesser oder einen Schlitz von 8 x 34 mm vorzusehen ist. An der Flügeloberkante ist eine Druckausgleichsöffnung von mind. 5 mm Größe vorzunehmen. Für feste Flügel muss die äußere Dichtung (080.9002.04) über einen Abstand von 50 mm unterbrochen werden. Die Entwässerungsöffnungen sind grundsätzlich am tiefsten Punkt der Profilkontur anzubringen

Bemerkung: Spezifische Entwässerungsbohrungen sind gemäß der Seite 34.f. ... vorzunehmen.

II.1.2.4 Dichtungen

Alle angebotenen Dichtungsprofile bestehen aus EPDM mit einer hohen Alterungs- und Witterungsbeständigkeit. Die Verarbeitung der Dichtungen hat sorgfältig und entsprechend den folgenden Hinweisen zu erfolgen:

a. Einbringen der Verglasungsdichtungen/Dichtungen.

Verfahrensweise:

1. Die Verglasungsdichtung wird je nach Erfordernis mit einer speziellen Schere (Art. Nr. 090.0121.00) gerade oder auf Gehrung zugeschnitten. Je lfdm. Dichtung ist eine Überlänge von 10 mm hinzuzurechnen.
2. Das Einbringen der Dichtung erfolgt in die vorgesehenen Dichtungsaufnahmen. Beim Einbringen der Dichtungen wird der überlange Zuschnitt durch Stauchen der Dichtungsprofile ausgeglichen. Durch die Anwendung des Silikonssprays (Art. Nr. 086.9551.--) wird das Einbringen der Dichtungen erleichtert.
3. Die Gehrungs- oder T-Stöße der Dichtungen sollen grundsätzlich mit unserem Vulkanisierkleber (Unzionement Art. Nr. 084.9103) verklebt werden.

b. Bürstendichtungen.

Verfahrensweise:

1. Die Bürstendichtung wird je nach Erfordernis mit einer speziellen Schere (Art. Nr. 090.0121.00) gerade oder auf Gehrung zugeschnitten.
2. Das Einbringen der Dichtung erfolgt in die vorgesehenen Dichtungsaufnahmen. Durch die Anwendung des Silikonssprays (Art. Nr. 084.9551.--) wird das Einbringen der Dichtungen erleichtert.
3. Je nach der Art Profilverbindung (gerade) wird die Bürstendichtung an den Enden mit Sekundenkleber (Reynaglue Art. Nr. 084.9105.--) verklebt. Dank dieser Verklebung wird das Ausrutschen der Bürstendichtung vermieden.

c. Abdichtung unten und oben auf dem Wechselprofil.

Für eine gute Wasser- und Winddichtheit soll unten und oben auf dem Wechselprofil eine zusätzliche Abdichtung montiert werden:

- 2-rail Schiebetür (CP 155)
 - unten und oben Art. Nr. 062.8025.04
- Monorail Schiebetür (CP 155)
 - unten und oben Art. Nr. 062.8027.04
- 2-rail Hebeschiebetür (CP 155-LS)
 - unten Art. Nr. 062.8011.04
 - oben Art. Nr. 062.8036.04
- Monorail Hebeschiebetür (CP 155-LS)
 - unten Art. Nr. 062.8012.04
 - oben Art. Nr. 062.8037.04

Die Abdichtung oben muss nach Montage der Flügel montiert werden.

II.2 MONTAGE

II.2.1 Befestigung am Baukörper

Die Befestigung am Baukörper erfolgt durch systemabhängige Befestigungsanker, Rohrrahmendübel oder andere Befestigungsteile. Beim Einsatz von Schrauben und Dübeln ist zu gewährleisten, dass die Mindestrandabstände gemäß den Verarbeitungsrichtlinien der Befestigungshersteller eingehalten werden. Die Verankerung ist so zu wählen, dass die auf das Schiebeelement einwirkenden Lasten sicher an den Baukörper abgeleitet werden. Alle zum Einsatz kommenden Verankerungen sollen aus Aluminium oder Edelstahl bzw. korrosionsgeschützt sein, damit die Aluminiumprofile nicht angegriffen werden.

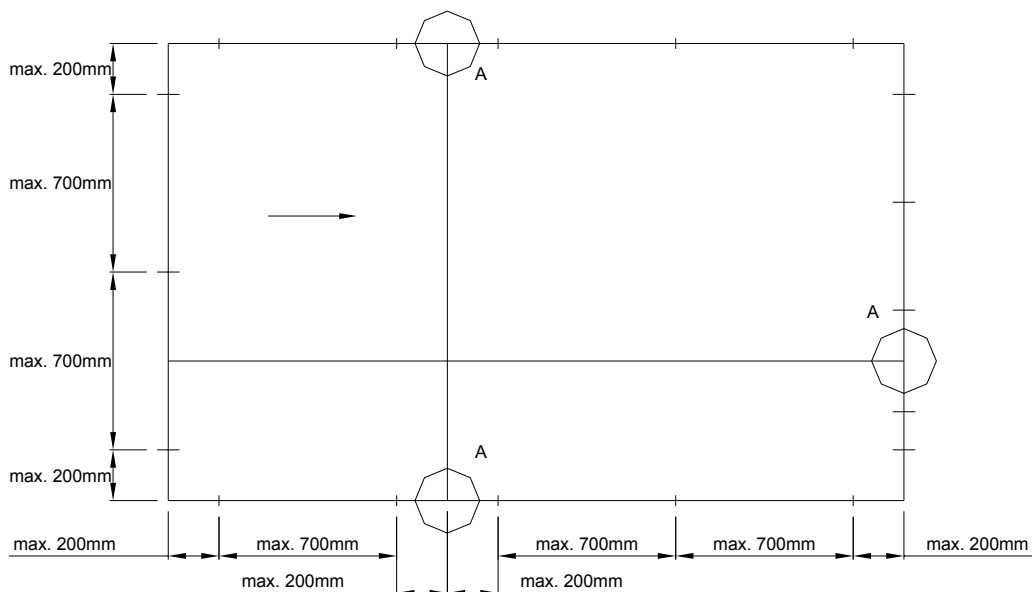

Die Anzahl der Befestigungspunkte ist wie folgt festzulegen:

- Je Rahmenseite müssen mind. zwei Befestigungen eingebracht werden.
- Der max. Abstand zur Rahmenecke darf 200 mm nicht unterschreiten.
- Der max. Abstand der Befestigungspunkte untereinander darf 700 mm nicht unterschreiten.
- Im Bereich von Pfosten- und Riegelanschluss sind die Befestigungspunkte ebenfalls 200 mm aus der Ecke vorzunehmen. Es wird empfohlen, die Befestigungspunkte in den Bereich der Eck- und Scherenlager sowie in den Bereich der Verriegelungspunkte (des Schlosses) zu legen.

Anmerkung: Die Befestigungen sollen so angebracht werden, dass ein eventuelles Arbeiten der Aluminiemelemente aufgenommen werden kann. Beim Einsatz von Schrauben und Dübeln durch die Profile dürfen die Kammern im Unterblendrahmen nicht durchbohrt werden um Wassereindringung im Bereich dieser Befestigung zu vermeiden.

II.2.2 Einbau der Beschläge

Die Auswahl der Beschläge hat entsprechend den Vorgaben des Systemlieferanten bzw. des Herstellers der Beschläge zu erfolgen. Die hier angegebenen Werte bzgl. der max. Flügelabmessungen, des max. Flügelgewichtes, der Anzahl der Verschlusspunkte sind einzuhalten. Bewegliche Teile sind, entsprechend den Angaben des Beschlagherstellers, mit säurefreiem Fett zu versehen. Eine Funktionsprüfung der Beschläge ist nach erfolgter Fertigung und Montage unerlässlich.

II.3 VERGLASUNG

Wegen der reduzierten Falzhöhe, muss man sich mit dem Glaslieferanten in Verbindung setzen im Hinblick auf die Garantie der Doppelverglasung. Alle Reynaers-Systeme können mit speziellen EPDM Dichtprofilen als Trockenverglasung oder als Nassverglasung (Silikon) auf Vorlegeband mit Vorprimern verarbeitet werden.

Wir empfehlen den Einsatz unserer EPDM Dichtprofile, da diese leicht zu verarbeiten sind und den Austausch beschädigter Verglasungen oder Paneele erleichtern.

Bei der Verglasung müssen folgende Punkte berücksichtigt werden:

Verglasungen oder Paneelen sollten so gemessen sein, dass mind. eine umlaufende Falzluft von 4 mm vorhanden ist. Für alle Reynaers-Systeme stehen sogenannte Klotzbrücken zur Verfügung. Diese überbrücken den Falzgrund, so dass die Luft um die Scheibe zirkulieren kann, und bieten durch ihre glatte Oberfläche eine saubere Auflage für die einzubringenden Verglasungsklotze. Die Verglasungsklotze sollten mind. 2 mm breiter als die Gesamtscheibenstärke.

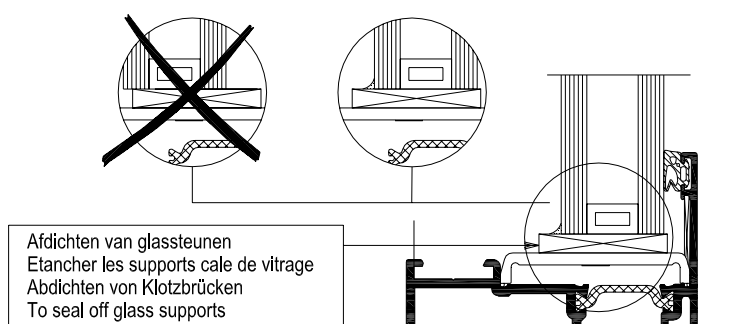

Bei der Verglasung unterscheiden wir nach Trag- und Distanzklotzen. Die Verglasungsklotze sind gegen Verrutschen zu sichern:

Tragklotze



Distanzklotze

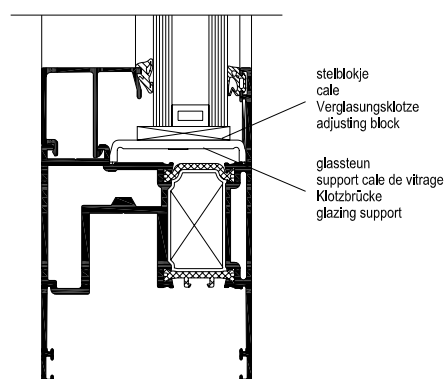
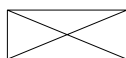

C1: Die Tragklotze

übertragen das Scheibengewicht auf den Rahmen bzw. Flügel und stellen die Gangbarkeit der beweglichen Flügel sicher.

C2: Die Distanzklotze

stellen den Abstand zwischen Rahmen und Verglasung sicher. Je nach Flügelöffnungsart können diese auch eine tragende Funktion übernehmen.

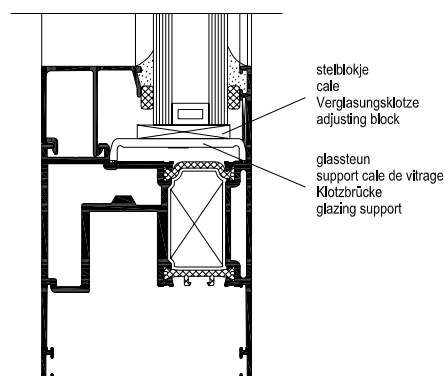

Die Anzahl und Position der Klotzbrücken bzw. Verglasungsklötze wird durch Verarbeitungsvorschriften der Isolierglasindustrie und den Technischen Richtlinien des Glaserhandwerks vorgegeben.

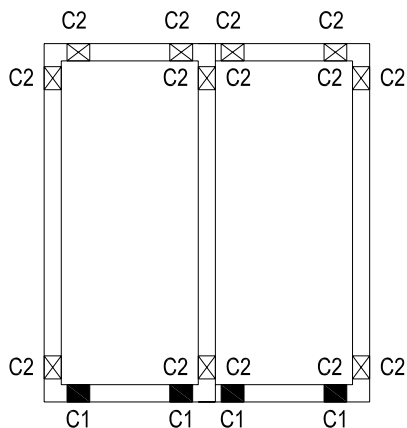

Nachstehend eine Übersicht über den Sitz und die Anzahl der Verglasungsklötze in den verschiedenen Typen von Schiebeelementen.

Bei schiebenden Flügeln wird das Scheibengewicht auf die Laufwagen übertragen. Die Verglasungsklötze (C1) müssen also im Bereich der Laufwagen montiert werden.

Bei festen Flügeln wird das Scheibengewicht auf die Stütze des festen Flügels übertragen. Die Verglasungsklötze (C1) müssen also im Bereich dieser Stütze montiert werden.





C

Profielen

Profilés

Profiles

Profile

Art. N°			Art. N°		
004.3130.XX	34.C.037	D0013865	030.3200.XX	34.C.032	D0013861
004.3167.XX	34.C.038	D0013864	030.3370.XX	34.C.043	D0013868
004.3843.XX	34.C.037	D0013865	030.3606.XX	34.C.032	D0013861
005.0276.XX	34.C.031	D0044306	030.3607.XX	34.C.032	D0013861
006.0305.04	34.C.014	D0013847	030.3608.XX	34.C.032	D0013861
006.0317.XX	34.C.046	D0074761	030.3609.XX	34.C.032	D0013861
006.0318.XX	34.C.046	D0074761	030.3610.XX	34.C.032	D0013861
006.0320.XX	34.C.015	D0013848	030.3611.XX	34.C.031	D0044306
006.0324.XX	34.C.016	D0013849	030.3612.XX	34.C.031	D0044306
006.0326.XX	34.C.016	D0013849	030.3613.XX	34.C.031	D0044306
006.0345.XX	34.C.023	D0013854	030.3614.XX	34.C.031	D0044306
006.0360.XX	34.C.010	D0013843	030.3615.XX	34.C.031	D0044306
006.0362.XX	34.C.017	D0013850	030.3644.XX	34.C.034	D0013859
006.0363.XX	34.C.017	D0013850	030.3645.XX	34.C.034	D0013859
006.0365.XX	34.C.045	D0059657	030.3646.XX	34.C.034	D0013859
006.0370.XX	34.C.042	D0013867	030.3647.XX	34.C.034	D0013859
006.0371.XX	34.C.041	D0013866	030.3648.XX	34.C.033	D0013860
006.1300.XX	34.C.010	D0013843	030.3649.XX	34.C.033	D0013860
006.1301.04	34.C.010	D0013843	030.3650.XX	34.C.033	D0013860
006.1302.XX	34.C.011	D0013844	030.3890.XX	34.C.043	D0013868
006.1303.04	34.C.011	D0013844	043.1028.XX	34.C.042	D0013867
006.1304.XX	34.C.013	D0013846	0K8.3824.XX	34.C.029	D0013858
006.1306.XX	34.C.012	D0013845	0M0.1505.XX	34.C.024	D0013853
006.1322.XX	34.C.015	D0013848			
006.1340.XX	34.C.021	D0013851			
006.1341.04	34.C.024	D0013853			
006.1342.XX	34.C.024	D0013853			
006.1343.00	34.C.024	D0013853			
006.1344.XX	34.C.022	D0013852			
006.1346.XX	34.C.030	D0046576			
006.1400.XX	34.C.018	D0044533			
006.1402.XX	34.C.019	D0044575			
006.1406.XX	34.C.020	D0044579			
007.0767.01	34.C.046	D0074761			
008.3113.XX	34.C.026	D0013856			
008.3114.XX	34.C.028	D0013857			
008.3120.XX	34.C.026	D0013856			
008.3123.XX	34.C.027	D0075003			
008.3824.XX	34.C.029	D0013858			
008.3848.XX	34.C.040	D0075000			
009.1886.XX	34.C.042	D0013867			
011.4631.--	34.C.010	D0013843			
030.0080.XX	34.C.039	D0074999			
030.0138.00	34.C.041	D0013866			
030.1097.00	34.C.025	D0013855			
030.1098.00	34.C.025	D0013855			
030.1141.00	34.C.044	D0013869			
030.1142.XX	34.C.038	D0013864			
030.1143.XX	34.C.037	D0013865			
030.3099.XX	34.C.025	D0013855			

CP 155-LS

PROFIELLIJST
LISTE DES PROFILES
LIST OF PROFILES
PROFILLISTE



CP 155 CP 155-LS

PROFIELOVERZICHT
APERCU DES PROFILES
PROFILE OVERVIEW
PROFILUEBERSICHT



VLEUGEL
OUVRANT
VENT
FLUEGEL

		L_m	$I_x \text{ cm}^4$	$W_x \text{ cm}^3$	$a_x \text{ mm}$	$I_y \text{ cm}^4$	$W_y \text{ cm}^3$	$a_y \text{ mm}$	
006.1340.XX		7.00/4.80	39.205	11.252	33.16	36.723	7.057	49.96	

VLEUGEL INBRAAKWEREND
OUVRANT PROTECTION ANTI-VOL
VENT BURGLAR PROTECTION
FLUEGEL EINBRUCHHEMMENT

		L_m	$I_x \text{ cm}^4$	$W_x \text{ cm}^3$	$a_x \text{ mm}$	$I_y \text{ cm}^4$	$W_y \text{ cm}^3$	$a_y \text{ mm}$	
006.1344.XX		4.80	39.244	11.208	32.99	40.291	7.537	48.54	

WISSELPROFIEL KUNSTSTOF
CHICANE MATIERE SYNTHETIQUE
SYNTHETIC MEETING SECTION
WECHSELPROFIL KUNSTSTOFF











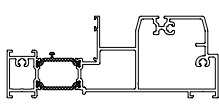

		L_m	$I_x \text{ cm}^4$	$W_x \text{ cm}^3$	$a_x \text{ mm}$	$I_y \text{ cm}^4$	$W_y \text{ cm}^3$	$a_y \text{ mm}$	
006.1341.04		6.00	1.437	0.633	11.03	6.678	1.913	25.19	
006.1342.XX		6.00	19.316	4.423	37.63	0.608	0.435	4.03	
006.1343.00		6.00	23.403	9.646	24.26	19.634	5.681	27.44	
006.0345.XX		4.00	25.726	5.732	42.12	2.647	1.572	16.84	
006.1346.XX		6.00	73.951	11.952	34.63	14.650	3.267	14.16	
0M0.1505.XX		6.00	0.140	0.187	7.50	0.015	0.062	2.50	

CP 155 CP 155-LS

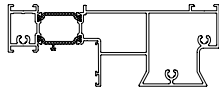



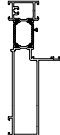



PROFIELOVERZICHT
APERCU DES PROFILES
PROFILE OVERVIEW
PROFILUEBERSICHT

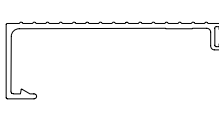

BUITENKADER DORMANT OUTER FRAME BLENDRAHMEN

			$I_x \text{ cm}^4$	$W_x \text{ cm}^3$	ax mm	$I_y \text{ cm}^4$	$W_y \text{ cm}^3$	ay mm	
006.0320.XX		7.00	162.919	19.082	69.62	38.929	11.769	26.92	
006.1322.XX		7.00	191.947	23.037	71.68	35.798	10.631	26.33	
006.0324.XX		4.00	142.471	18.173	76.60	21.055	5.497	21.70	
006.0326.XX		4.00	130.938	16.301	80.33	16.774	4.167	19.75	

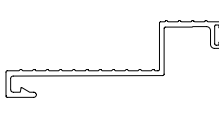
AFDEKPROFIEL BUITENKADER PROFILE DE RECOUVREMENT DORMANT COVERING PROFILE OUTER FRAME ABDECKPROFIL BLENDRAHMEN













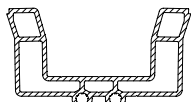

			$I_x \text{ cm}^4$	$W_x \text{ cm}^3$	ax mm	$I_y \text{ cm}^4$	$W_y \text{ cm}^3$	ay mm	
006.0362.XX		7.00	19.939	4.021	49.58	2.111	0.953	22.14	
006.0363.XX		7.00	17.193	4.165	41.28	1.880	1.215	13.52	

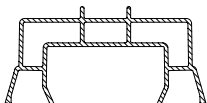
CP 155 CP 155-LS

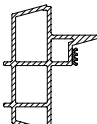



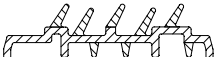

PROFIELOVERZICHT
APERCU DES PROFILES
PROFILE OVERVIEW
PROFILUEBERSICHT



PROFIEL BUITENKADER KUNSTSTOF PROFILE SYNTHETIQUE DORMANT SYNTHETIC PROFILE OUTER FRAME KUNSTSTOFFPROFIL BLENDRAHMEN

			$I_x \text{ cm}^4$	$W_x \text{ cm}^3$	$a_x \text{ mm}$	$I_y \text{ cm}^4$	$W_y \text{ cm}^3$	$a_y \text{ mm}$	
006.1301.04		7.00	3.073	1.711	13.35	12.969	4.298	30.18	
006.1303.04		7.00	23.922	6.308	37.92	5.519	2.790	18.42	
006.0305.04		6.00	2.065	0.954	14.36	4.736	1.878	23.06	
011.4631.--		7.00	-	-	-	-	-	-	
006.0910.04		7.00	2.297	0.977	21.37	0.099	0.149	5.73	

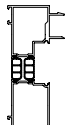
BUITENKADER ZIJKANT DORMANT COTE LATERAL OUTER FRAME SIDE BLENDRAHMEN SENKRECHT











			$I_x \text{ cm}^4$	$W_x \text{ cm}^3$	$a_x \text{ mm}$	$I_y \text{ cm}^4$	$W_y \text{ cm}^3$	$a_y \text{ mm}$	
006.1304.XX		6.00	209.341	24.770	84.51	39.528	10.039	28.63	

CP 155 CP 155-LS

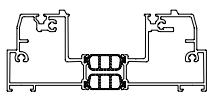

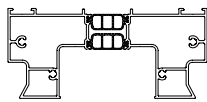

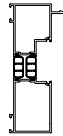





PROFIELOVERZICHT
APERCU DES PROFILS
PROFILE OVERVIEW
PROFILUEBERSICHT



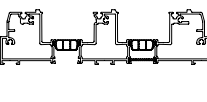

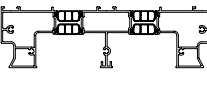

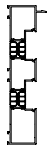

BUITENKADER DORMANT OUTER FRAME BLENDRAHMEN

			$I_x \text{ cm}^4$	$W_x \text{ cm}^3$	ax mm	$I_y \text{ cm}^4$	$W_y \text{ cm}^3$	ay mm	
006.1300.XX		7.00	216.247	27.782	77.84	53.752	16.849	31.10	
006.1302.XX		7.00/4.80	256.789	33.134	77.50	57.868	15.279	32.12	
006.1306.XX		6.00	198.518	24.541	80.89	34.118	8.213	26.46	

BUITENKADER 3-RAIL DORMANT 3-RAIL OUTER FRAME 3-RAIL BLENDRAHMEN 3-RAIL

			$I_x \text{ cm}^4$	$W_x \text{ cm}^3$	ax mm	$I_y \text{ cm}^4$	$W_y \text{ cm}^3$	ay mm	
006.1400.XX		7.00	900.669	74.256	121.29	78.297	24.022	30.41	
006.1402.XX		7.00	829.127	68.509	121.03	79.003	20.147	30.79	
006.1406.XX		6.00	642.510	51.420	124.96	47.461	11.225	25.72	

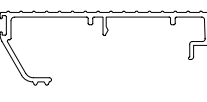
KLIPS BUITENKADER CLIP DORMANT CLIP OUTER FRAME KLEMME BLENDRAHMEN











			$I_x \text{ cm}^4$	$W_x \text{ cm}^3$	ax mm	$I_y \text{ cm}^4$	$W_y \text{ cm}^3$	ay mm	
006.0360.XX		7.00	21.640	4.923	43.95	1.875	0.857	21.89	

CP 155 CP 155-LS

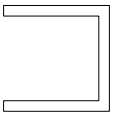

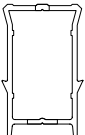









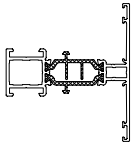

PROFIELOVERZICHT
APERCU DES PROFILS
PROFILE OVERVIEW
PROFILUEBERSICHT

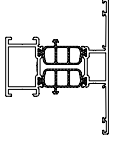

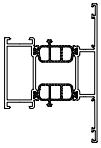
U-PROFIEL
PROFILE-U
U-PROFILE
U-PROFIL

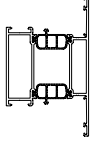
			$I_x \text{ cm}^4$	$W_x \text{ cm}^3$	ax mm	$I_y \text{ cm}^4$	$W_y \text{ cm}^3$	ay mm	
0U2.0202.XX		6.00	0.453	0.360	7.43	0.719	0.719	10.00	
030.1097.00		7.00	10.260	3.656	28.06	4.477	2.763	16.20	
030.1098.00		7.00	19.656	6.418	25.35	6.287	3.880	16.20	
030.3099.XX		7.00	9.625	2.614	23.19	5.654	3.220	17.56	

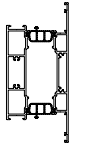
T-PROFIEL
TRAVERSE
TRANSOM-MULLION
SPROSSE















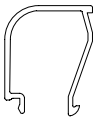

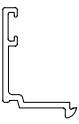







			$I_x \text{ cm}^4$	$W_x \text{ cm}^3$	ax mm	$I_y \text{ cm}^4$	$W_y \text{ cm}^3$	ay mm	
008.3113.XX		7.00	16.916	4.166	27.40	8.602	2.264	38.00	
008.3120.XX		7.00	26.891	6.830	28.63	16.299	3.663	44.50	
008.3114.XX		7.00	31.671	8.154	29.16	28.302	5.549	51.00	
008.3123.XX		7.00	36.452	9.486	29.57	45.435	7.902	57.50	
008.3824.XX		7.00	59.548	16.217	31.28	142.536	18.511	77.00	

CP 155 CP 155-LS

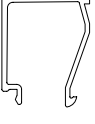
PROFIELOVERZICHT
APERCU DES PROFILES
PROFILE OVERVIEW
PROFILUEBERSICHT

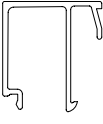

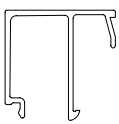
GLASLAT
PARCLOSE
GLAZING BEAD
GLASLEISTE















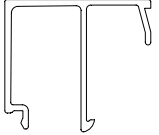

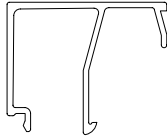

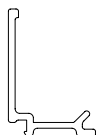

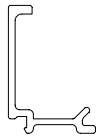

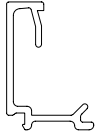
			$I_x \text{ cm}^4$	$W_x \text{ cm}^3$	ax mm	$I_y \text{ cm}^4$	$W_y \text{ cm}^3$	ay mm	
005.0276.XX		7.00	1.002	0.585	17.12	0.817	0.673	11.05	
030.3200.XX		7.00	0.632	0.362	11.70	0.273	0.191	5.17	
030.3606.XX		7.00	0.277	0.198	13.99	0.919	0.612	14.14	
030.3607.XX		7.00	0.333	0.255	13.08	0.895	0.581	15.39	
030.3608.XX		7.00	0.431	0.354	12.15	0.914	0.560	16.34	
030.3609.XX		7.00	0.544	0.483	11.26	0.967	0.572	16.89	
030.3610.XX		7.00	0.691	0.646	10.70	1.022	0.590	17.32	
030.3611.XX		7.00	0.875	0.690	12.67	1.076	0.609	17.69	
030.3612.XX		7.00	0.995	0.670	14.85	1.148	0.620	18.53	
030.3613.XX		7.00	1.192	0.696	17.13	1.184	0.629	18.81	

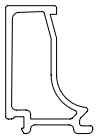
CP 155 CP 155-LS

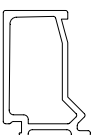
GLASLATTEN
PARCLOSES
GLAZING BEADS
GLASLEISTEN

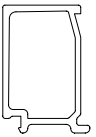

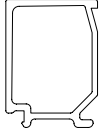
GLASLAT
PARCLOSE
GLAZING BEAD
GLASLEISTE













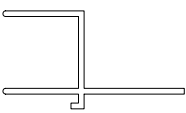

			$I_x \text{ cm}^4$	$W_x \text{ cm}^3$	ax mm	$I_y \text{ cm}^4$	$W_y \text{ cm}^3$	ay mm	
030.3614.XX		7.00	1.431	0.739	19.37	1.217	0.638	19.07	
030.3615.XX		7.00	1.750	0.821	21.31	1.252	0.647	19.35	
030.3644.XX		7.00	0.291	0.213	13.64	0.560	0.299	9.46	
030.3645.XX		7.00	0.293	0.213	13.79	0.737	0.423	10.79	
030.3646.XX		7.00	0.296	0.219	13.52	0.957	0.618	12.72	
030.3647.XX		7.00	0.376	0.315	11.94	1.072	0.699	12.86	
030.3648.XX		7.00	0.447	0.398	11.23	1.148	0.780	13.48	
030.3649.XX		7.00	0.548	0.520	10.55	1.211	0.857	14.13	
030.3650.XX		7.00	0.736	0.703	10.47	1.297	0.898	14.44	

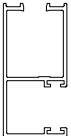
CP 155 CP 155-LS

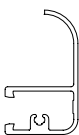
ROLLUIKGELEIDER
GUIDE A VOLET
SHUTTER GUIDE
ROLLADENFUEHRUNG

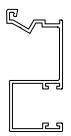

ROLLUIKGELEIDER
GUIDE A VOLET
SHUTTER GUIDE
ROLLADENFUEHRUNG















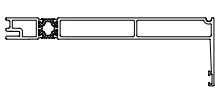



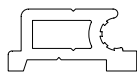

			$I_x \text{ cm}^4$	$W_x \text{ cm}^3$	$a_x \text{ mm}$	$I_y \text{ cm}^4$	$W_y \text{ cm}^3$	$a_y \text{ mm}$	
004.3130.XX		6.00	1.141	0.774	27.84	1.881	0.675	11.18	
004.3167.XX		6.00	9.873	3.327	28.51	3.238	2.151	12.95	
004.3843.XX		6.00	4.009	1.264	10.47	1.621	0.952	15.29	
030.1142.XX		6.00	13.153	3.911	31.19	3.015	1.909	15.79	
030.1143.XX		6.00	3.495	1.143	14.53	2.214	1.076	20.57	

CP 155 CP 155-LS

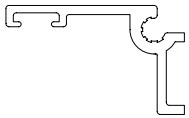
HULPPROFIELEN
PROFILES DE RACCORDEMENT
ADDITIONAL PROFILES
ZUSATZPROFILE

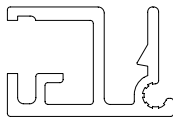

VERBINDINGSPROFIEL GOOT
PROFILE DE RACCORDEMENT GOUTTIERE
CONNECTION PROFILE GUTTER
KUPPLUNGSPROFIL RINNE

			$I_x \text{ cm}^4$	$W_x \text{ cm}^3$	ax mm	$I_y \text{ cm}^4$	$W_y \text{ cm}^3$	ay mm	
006.0370.XX		7.00	147.133	18.107	71.65	5.660	1.431	39.55	
006.0371.XX		7.00	120.097	15.082	75.37	4.145	3.255	12.73	
009.1886.XX		7.00	0.884	0.812	9.31	3.914	1.307	20.07	
030.0138.00		7.00	0.043	0.102	4.01	0.150	0.174	8.39	
030.1141.00		7.00	5.619	1.673	21.01	1.162	0.789	14.73	
030.3370.XX		7.00	0.253	0.197	5.14	0.640	0.342	18.69	
030.3890.XX		7.00	0.682	0.648	7.58	1.066	0.765	13.93	
043.1028.XX		6.00	0.098	0.103	9.58	0.295	0.254	11.60	

CP 155 CP 155-LS

BUITENKADERS
DORMANTS
OUTER FRAMES
BLENDRAHMEN



	A dm ² /m	P dm ² /m	L_m	I_x cm ⁴	W_x cm ³	a_x mm	I_y cm ⁴	W_y cm ³	a_y mm	
006.0360.XX	32.02	11.2	7.00	21.640	4.923	43.95	1.875	0.857	21.89	X Y
006.1300.XX	54.70	21.3	7.00/4.80	216.247	27.782	77.84	53.752	16.849	31.10	0 Y
006.1301.04	-	-	7.00	-	-	-	-	-	-	
011.4631.--	-	-	7.00	-	-	-	-	-	-	

006.1300.XX

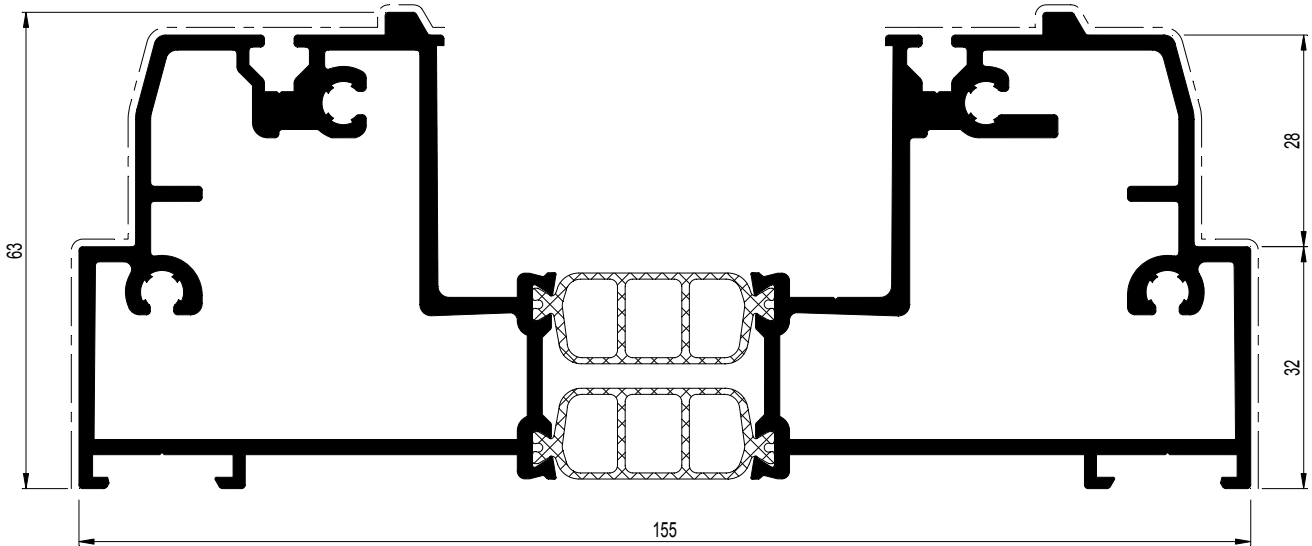

006.1301.04

ASA / PC

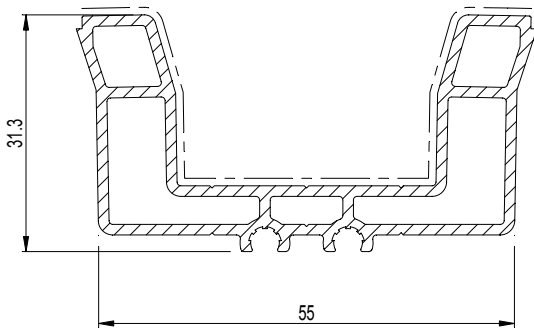

006.0360.XX

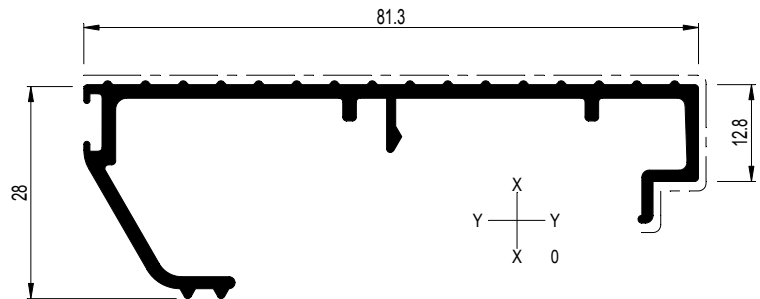

011.4631.--

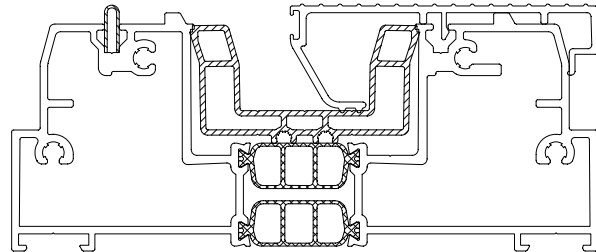
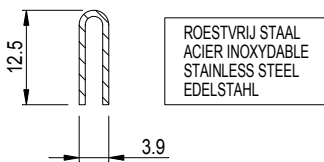

	006.1300.XX	
	068.7555.00 (2x)	095.30PN.00 of-ou-or-oder 095.B500.00
	068.8576.00 (2x)	097.0440.00
	052.5371.-- (4x)	097.0436.00

Profielen
Perfiles
Profiles
Profile

34.C.010
02/2009

D0013843

	A dm ² /m	P dm ² /m	L_m	I_x cm ⁴	W_x cm ³	a_x mm	I_y cm ⁴	W_y cm ³	a_y mm	X Y X Y 0
006.1302.XX	55.33	23.3	7.00/4.80	256.789	33.134	77.50	57.868	15.279	32.12	
006.1303.04	-	-	7.00	-	-	-	-	-	-	

006.1302.XX

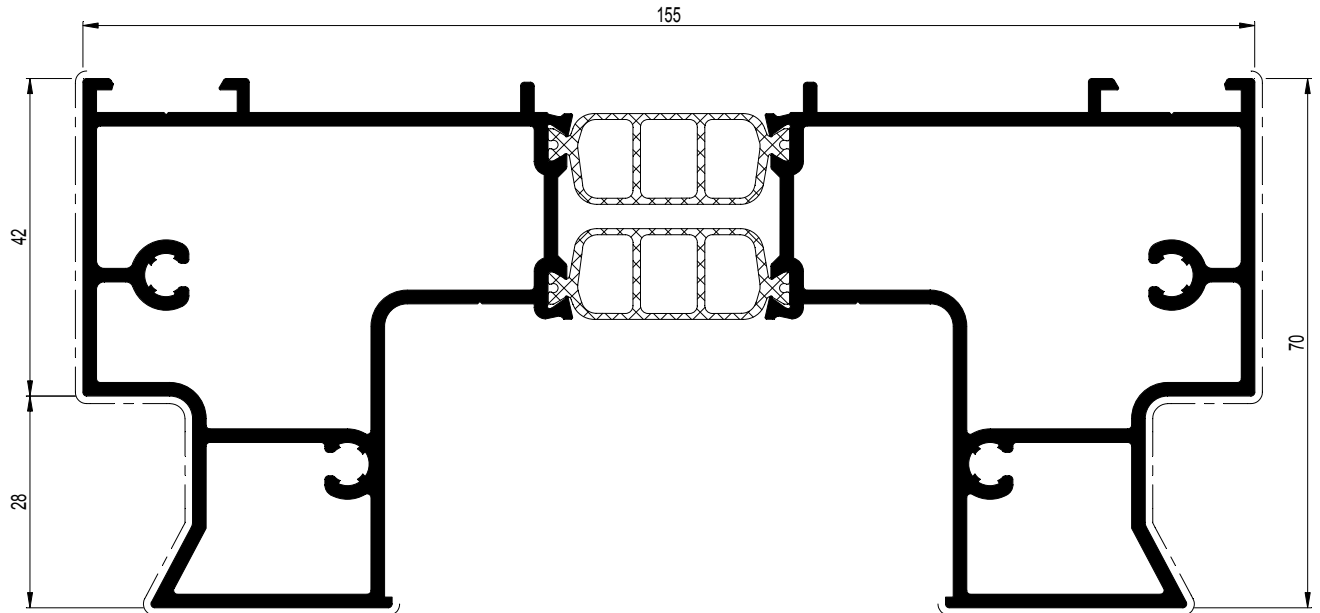

006.1303.04

HPVC

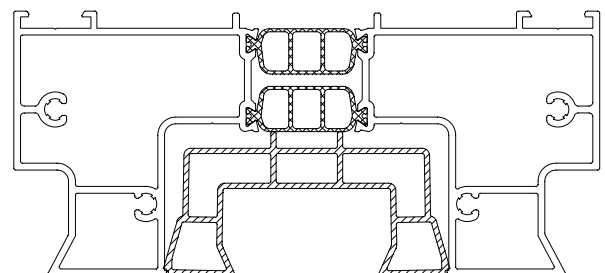
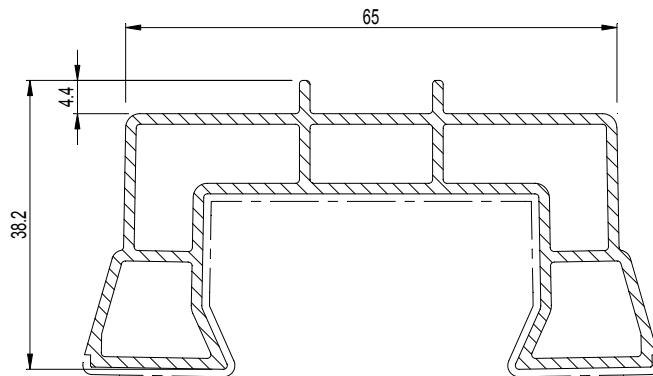

	006.1302.XX	
	052.5371.-- (4x)	097.0436.00

CP 155-LS

BUITENKADER
DORMANT
OUTER FRAME
BLENDRAHMEN



	A dm ² /m	P dm ² /m	L_m	I_x cm ⁴	W_x cm ³	ax mm	I_y cm ⁴	W_y cm ³	ay mm	Y X 0 Y
006.1306.XX	48.97	18.3	6.00	198.518	24.541	80.89	34.118	8.213	26.46	

006.1306.XX

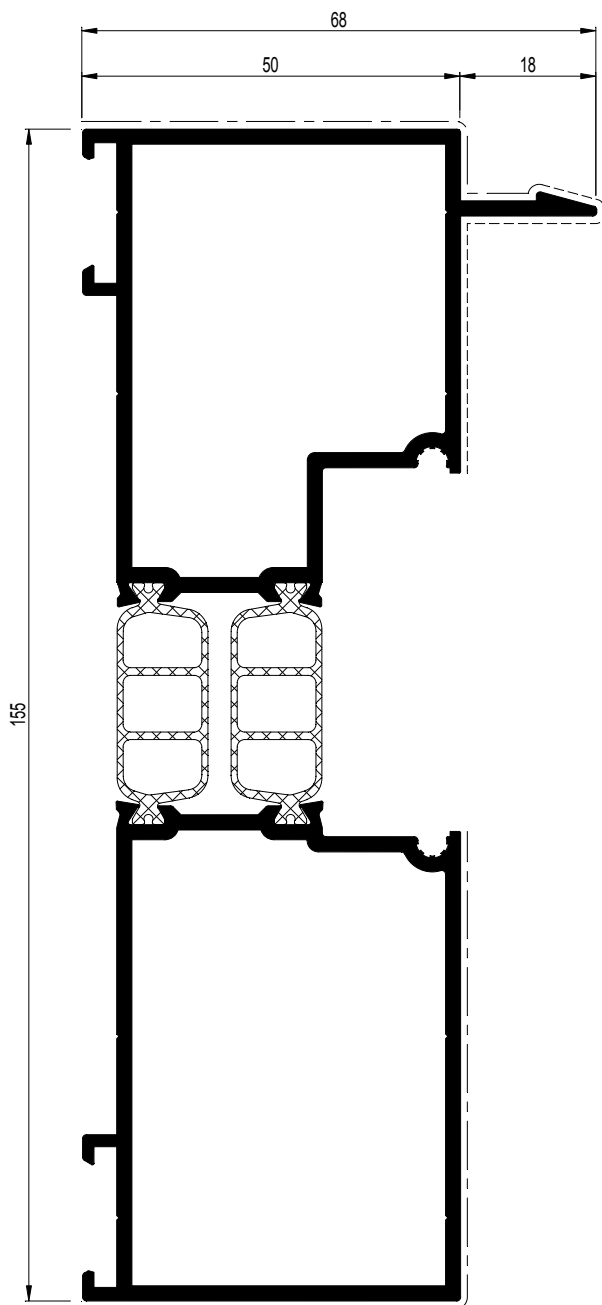

CP 155-LS

BUITENKADER INBRAAKWEREND
 DORMANT PROTECTION ANTI-VOL
 OUTER FRAME BURGLAR PROTECTION
 BLENDRAHMEN EINBRUCHHEMMEND

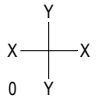

	$\frac{A}{dm^2/m}$	$\frac{P}{dm^2/m}$	$\leftarrow L_m \rightarrow$	$I_x \text{ cm}^4$	$W_x \text{ cm}^3$	$ax \text{ mm}$	$I_y \text{ cm}^4$	$W_y \text{ cm}^3$	$ay \text{ mm}$	
006.1304.XX	52.41	18.3	6.00	209.341	24.770	84.51	39.528	10.039	28.63	

006.1304.XX

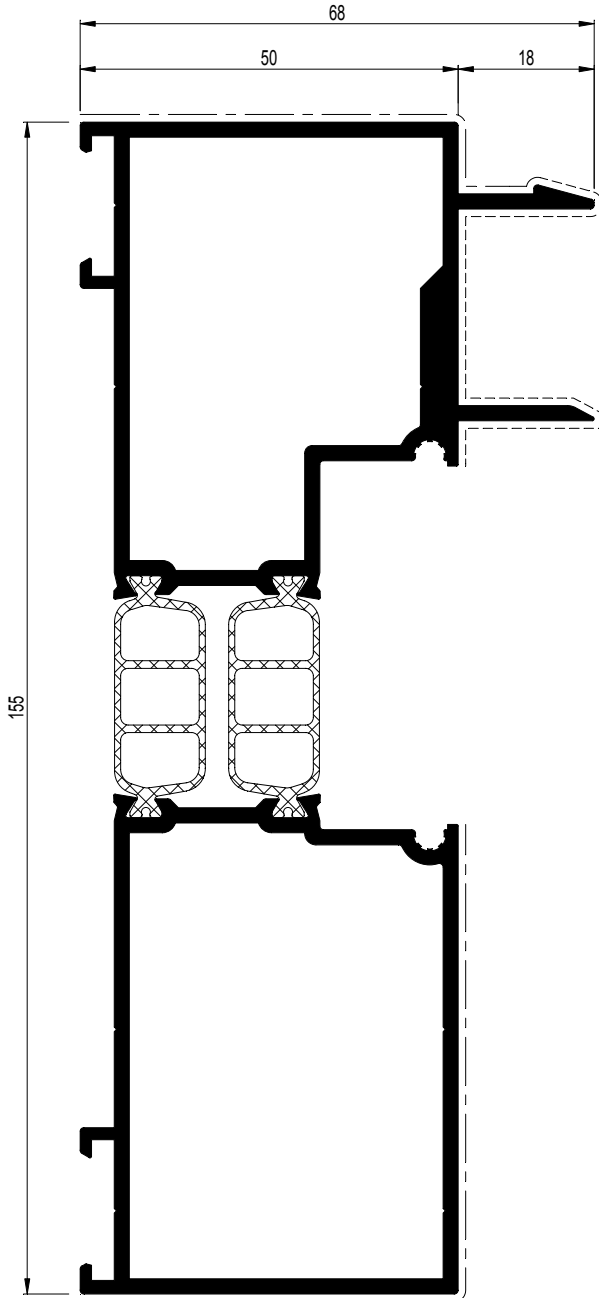

CP 155-LS

BUITENKADER
DORMANT
OUTER FRAME
BLENDRAHMEN



	A dm ² /m	P dm ² /m	L_m	I_x cm ⁴	W_x cm ³	a_x mm	I_y cm ⁴	W_y cm ³	a_y mm	Y X 0 Y
006.0305.04	-	-	6.00	-	-	-	-	-	-	

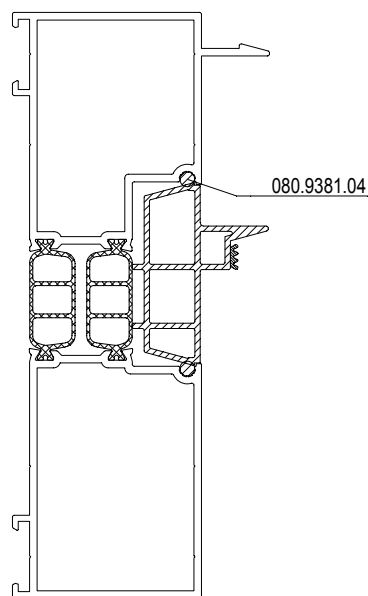
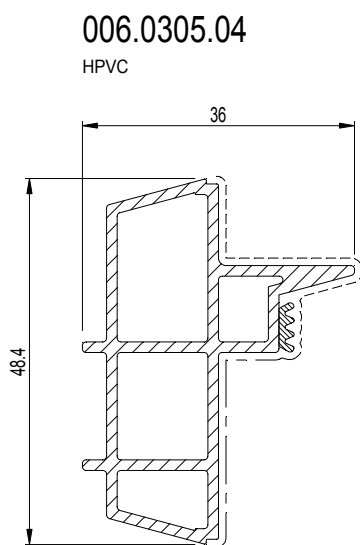

CP 155 CP 155-LS

BUITENKADERS MONORAIL
DORMANTS MONORAIL
OUTER FRAMES MONORAIL
BLENDRAHMEN MONORAIL



	A dm ² /m	P dm ² /m	L_m	I_x cm ⁴	W_x cm ³	a_x mm	I_y cm ⁴	W_y cm ³	a_y mm	X Y
006.0320.XX	55.13	21.0	7.00	162.919	19.082	69.62	38.929	11.769	26.92	X Y
006.1322.XX	54.27	24.4	7.00	191.947	23.037	71.68	35.798	10.631	26.33	X 0

006.1322.XX

Monorail

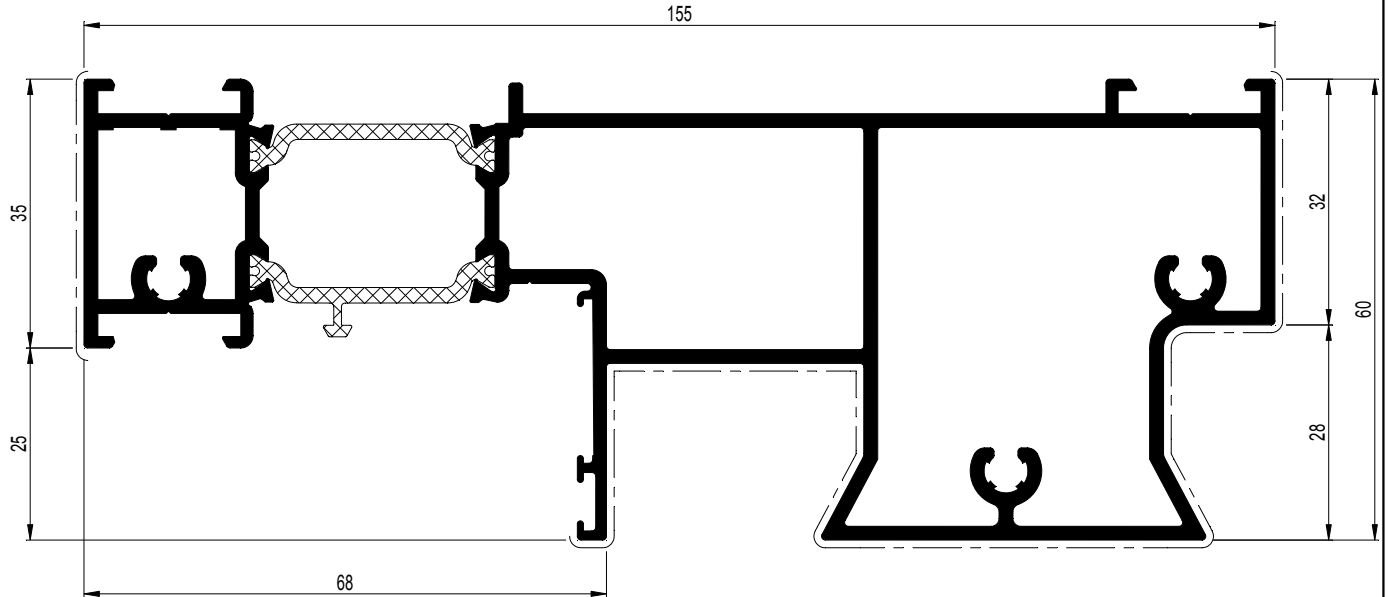

006.0320.XX

Monorail

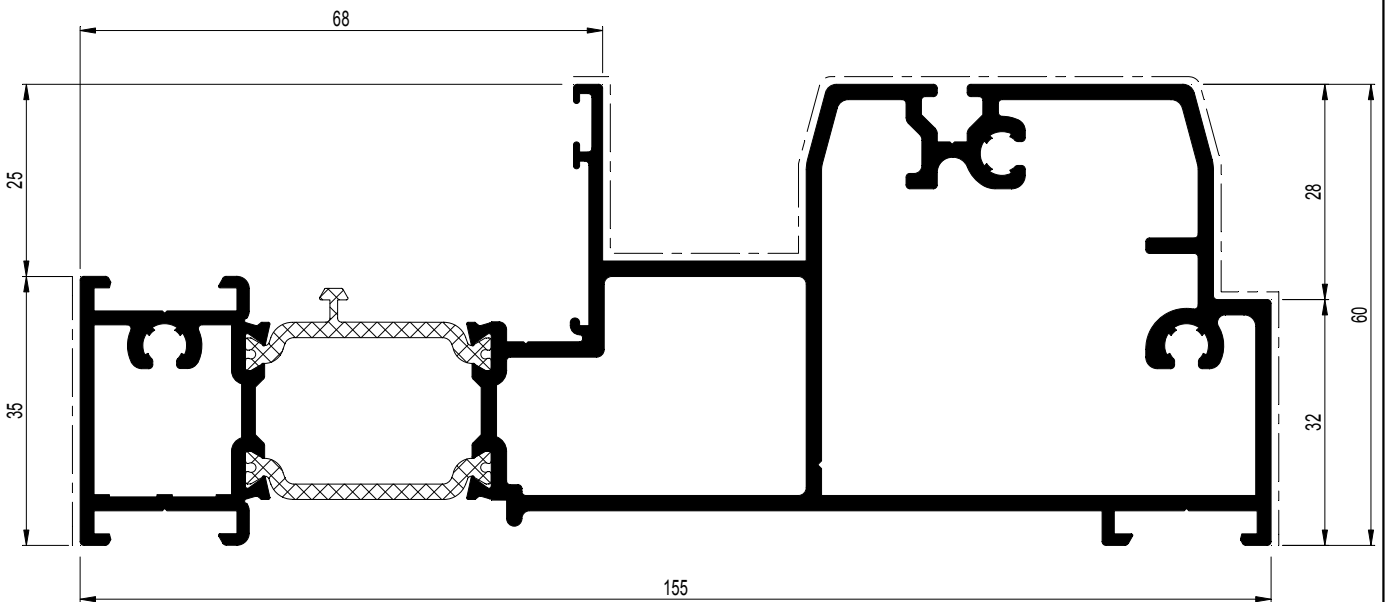

	006.0320.XX	
	068.7558.00	095.30PN.00 of-ou-or-oder 095.B500.00
	068.8574.00	097.0440.00
	052.5371.-- (3x)	097.0436.00
	069.6575.04	---
	060.8723.-- or 060.8725.00	---

	006.1322.XX	
	052.5371.-- (3x)	097.0436.00





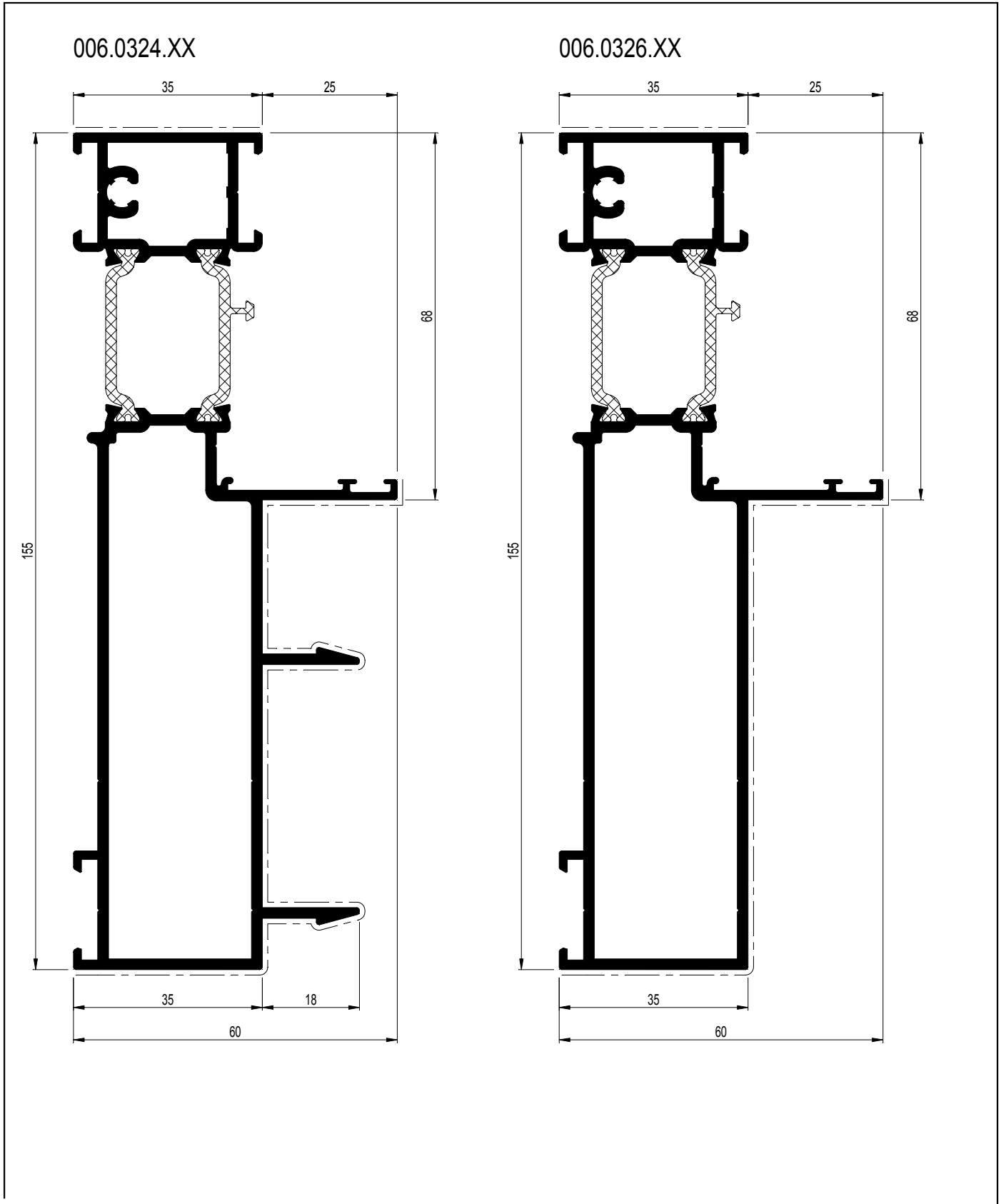

Profielen
Profils
Profiles
Profile

34.C.015
02/2009

D0013848

	$\frac{A}{dm^2/m}$	$\frac{P}{dm^2/m}$	L_m	$I_x \text{ cm}^4$	$W_x \text{ cm}^3$	ax mm	$I_y \text{ cm}^4$	$W_y \text{ cm}^3$	ay mm	Y X 0 Y
006.0324.XX	55.23	25.9	4.00	142.471	18.173	76.60	21.055	5.497	21.70	
006.0326.XX	48.06	18.7	4.00	130.938	16.301	80.33	16.774	4.167	19.75	





	006.0324.XX			006.0326.XX	
	052.5371.--	097.0437.00		052.5371.--	097.0437.00

CP 155 CP 155-LS

AFDEKPROFIEL BUITENKADER MONORAIL
 PROFILE DE RECOUVREMENT DORMANT MONORAIL
 COVERING PROFILE OUTER FRAME MONORAIL
 ABDECKPROFIL BLENDRAHMEN MONORAIL



	$\frac{A}{dm^2/m}$	$\frac{P}{dm^2/m}$	$\leftarrow L_m \rightarrow$	$I_x \text{ cm}^4$	$W_x \text{ cm}^3$	$ax \text{ mm}$	$I_y \text{ cm}^4$	$W_y \text{ cm}^3$	$ay \text{ mm}$	
006.0362.XX	26.70	11.6	7.00	19.939	4.021	49.58	2.111	0.953	22.14	
006.0363.XX	26.68	11.5	7.00	17.193	4.165	41.28	1.880	1.215	13.52	

006.0362.XX

Monorail

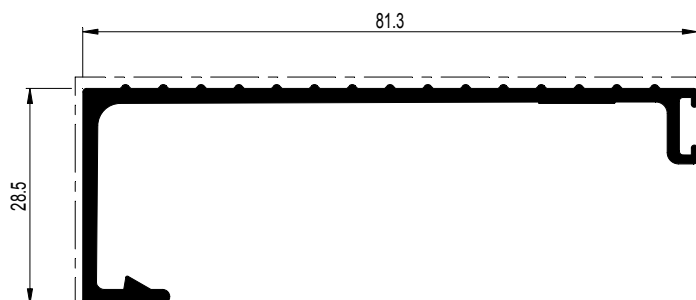

006.0363.XX

Monorail

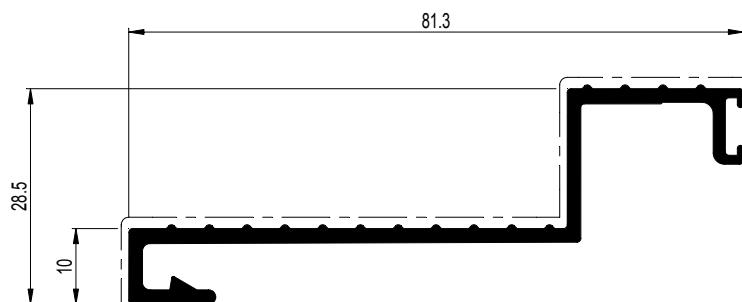

CP 155 CP 155-LS

BUITENKADER 3-RAIL
DORMANT 3-RAIL
OUTER FRAME 3-RAIL
BLENDRAHMEN 3-RAIL



	A dm ² /m	P dm ² /m	L_m	I_x cm ⁴	W_x cm ³	a_x mm	I_y cm ⁴	W_y cm ³	a_y mm	Y X 0 Y
006.1400.XX	82.08	24.4	7.00	900.669	74.256	121.29	78.297	24.022	30.41	

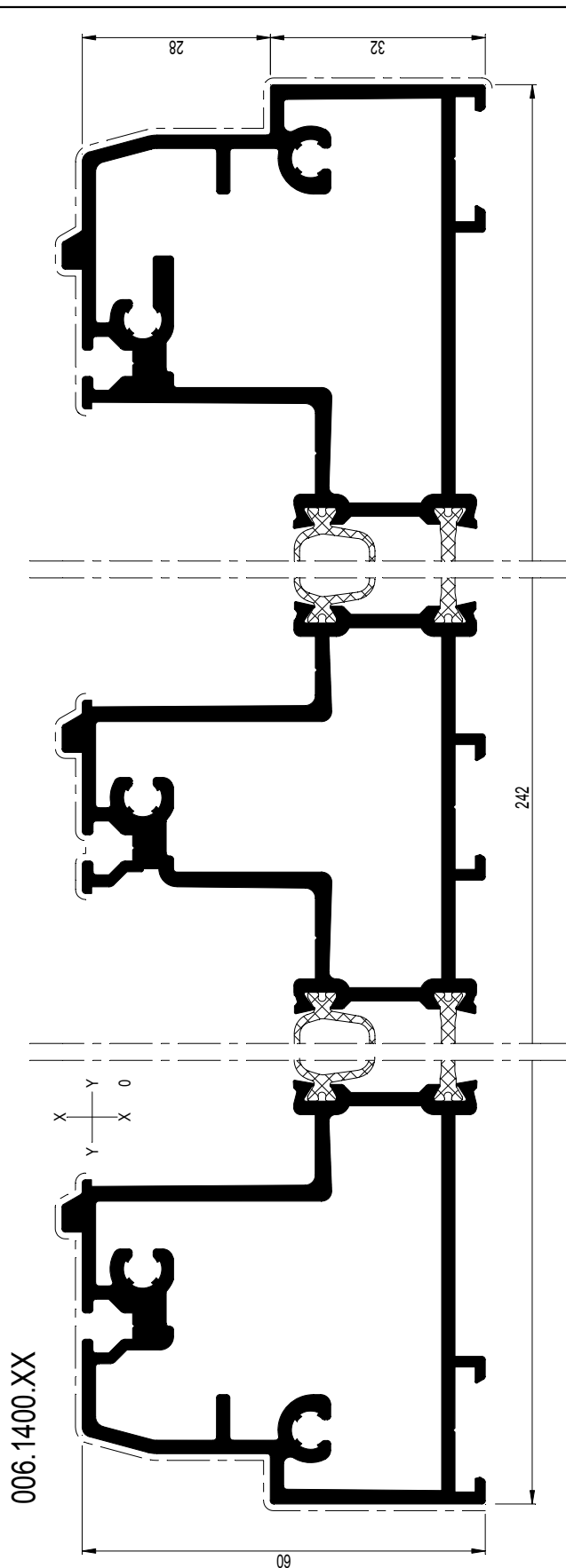

	006.1400.XX	
	068.7555.00 (2x)	---
	068.8576.00 (2x)	---
	052.5371.-- (5x)	097.0698.00
	069.6576.04	---

Profielen
Profils
Profiles
Profile

34.C.018
02/2009

D0044533

CP 155-LS

BUITENKADER 3-RAIL
 DORMANT 3-RAIL
 OUTER FRAME 3-RAIL
 BLENDRAHMEN 3-RAIL



	A dm ² /m	P dm ² /m	L_m	I_x cm ⁴	W_x cm ³	a_x mm	I_y cm ⁴	W_y cm ³	a_y mm	Y X 0 Y
006.1402.XX	85.04	24.7	7.00	829.127	68.509	121.03	79.003	20.147	30.79	

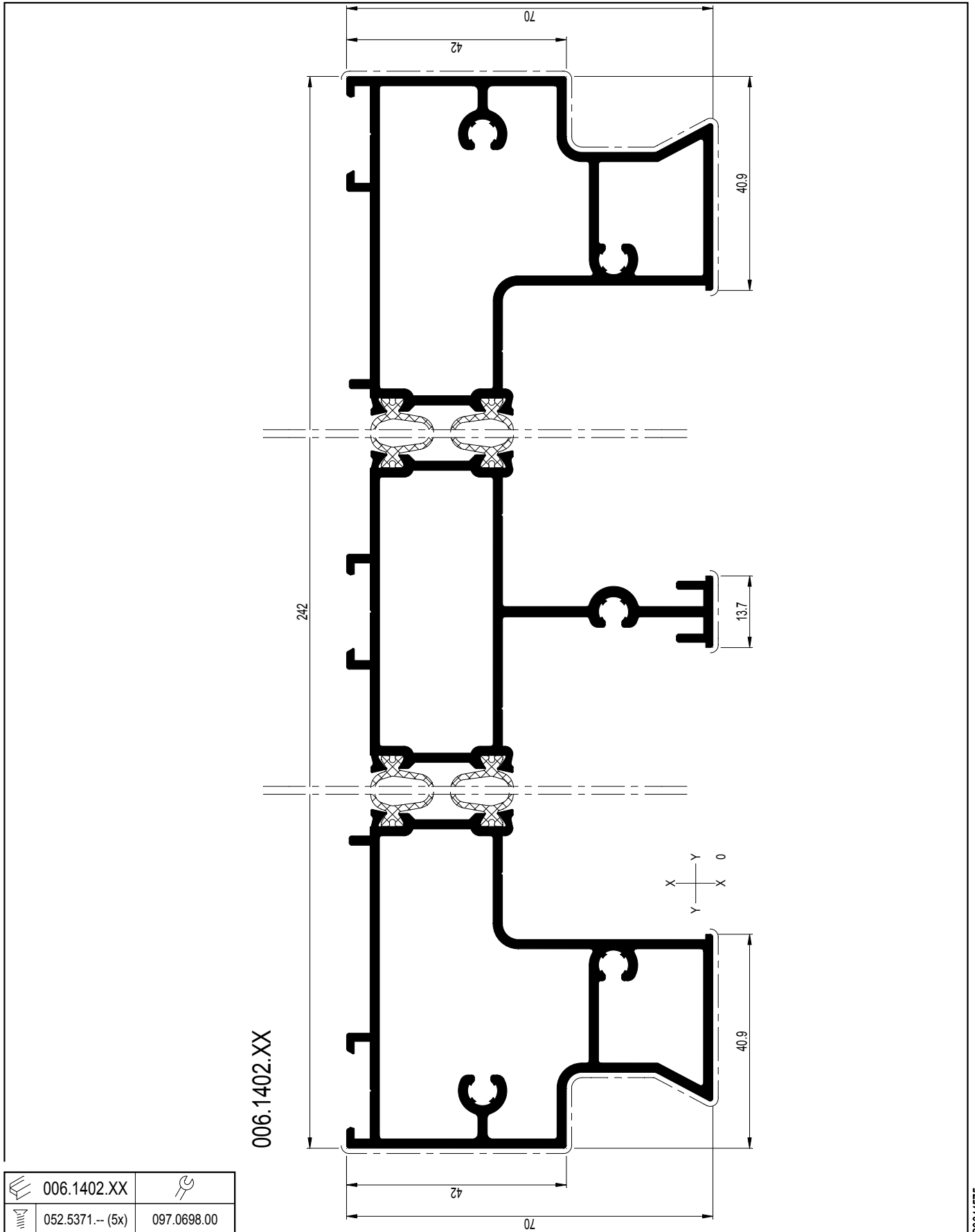

Profielen
 Profils
 Profiles
 Profile

CP 155 CP 155-LS

BUITENKADER 3-RAIL
DORMANT 3-RAIL
OUTER FRAME 3-RAIL
BLENDRAHMEN 3-RAIL



	$\frac{A}{dm^2/m}$	$\frac{P}{dm^2/m}$	L_m	$I_x \text{ cm}^4$	$W_x \text{ cm}^3$	ax mm	$I_y \text{ cm}^4$	$W_y \text{ cm}^3$	ay mm	Y X 0 Y
006.1406.XX	69.12	22.3	6.00	642.510	51.420	124.96	47.461	11.225	25.72	

006.1406.XX

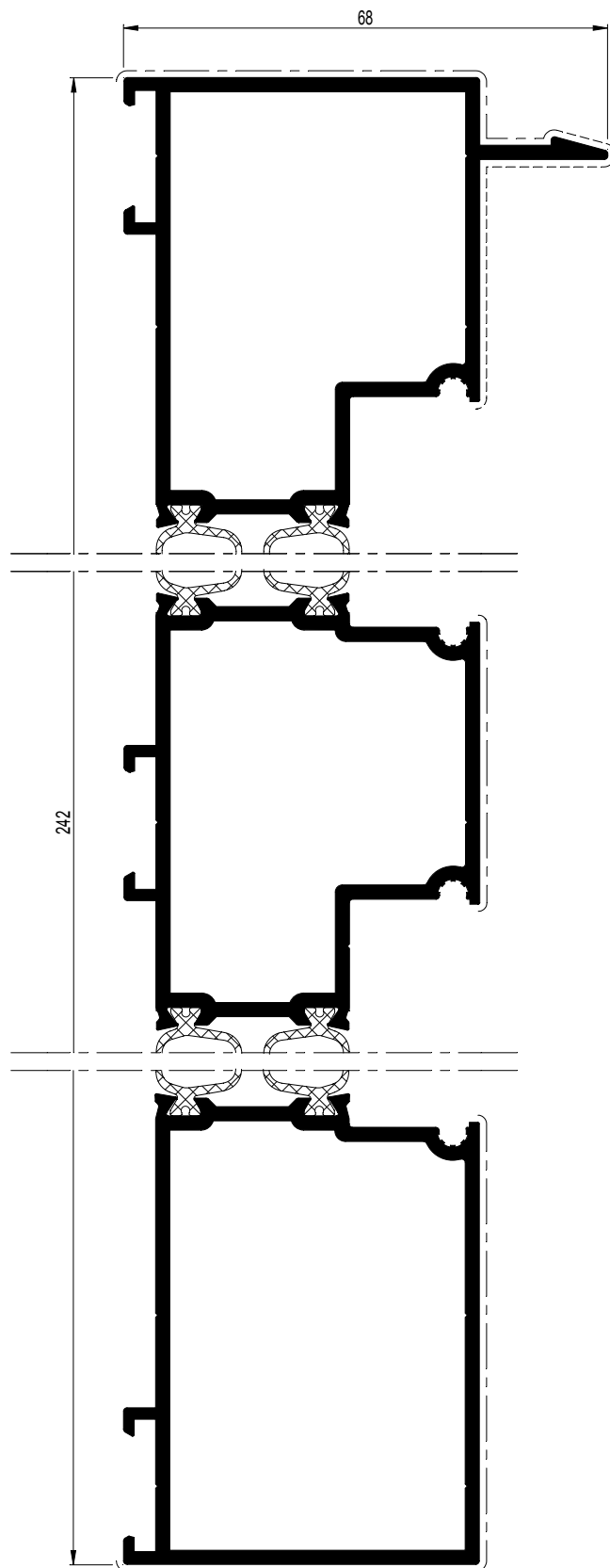

CP 155 CP 155-LS

VLEUGELS
OUVRANTS
VENTS
FLUEGEL



	$\frac{A}{dm^2/m}$	$\frac{P}{dm^2/m}$	$\leftarrow L_m \rightarrow$	$I_x \text{ cm}^4$	$W_x \text{ cm}^3$	$a_x \text{ mm}$	$I_y \text{ cm}^4$	$W_y \text{ cm}^3$	$a_y \text{ mm}$	
006.1340.XX	50.21	19.1	7.00/4.80	39.205	11.252	33.16	36.723	7.057	49.96	

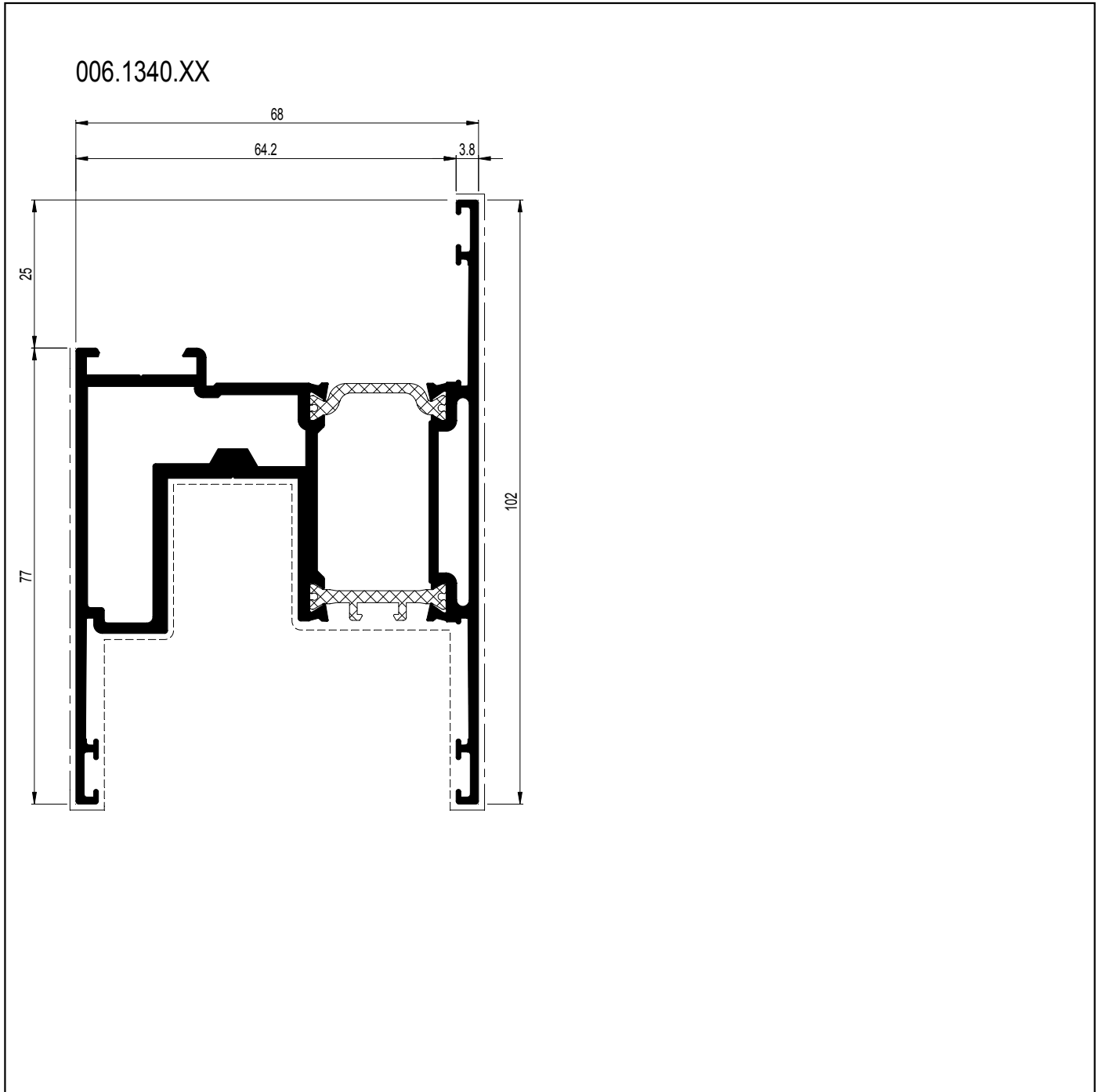

	006.1340.XX	
	068.7775.00	095.30PN.00 of-ou-or-oder 095.B500.00
	068.8835.00	097.0441.00
	068.8986.00	097.0374.00 of-ou-or-oder 097.0410.00 of-ou-or-oder 097.0463.00
	069.6569.04	---
	060.8723.-- (3x) or 060.8725.00 (3x)	---

Profielen
Profils
Profiles
Profile

34.C.021
02/2009

D0013851

CP 155 CP 155-LS

VLEUGELS INBRAAKWEREND
OUVRANTS PROTECTION ANTI-VOL
VENTS BURGLAR PROTECTION
FLUEGEL EINBRUCHHEMMEND



	A dm ² /m	P dm ² /m	L_m	I_x cm ⁴	W_x cm ³	ax mm	I_y cm ⁴	W_y cm ³	ay mm	X Y X 0
006.1344.XX	54.48	19.1	4.80	39.244	11.208	32.99	40.291	7.537	48.54	

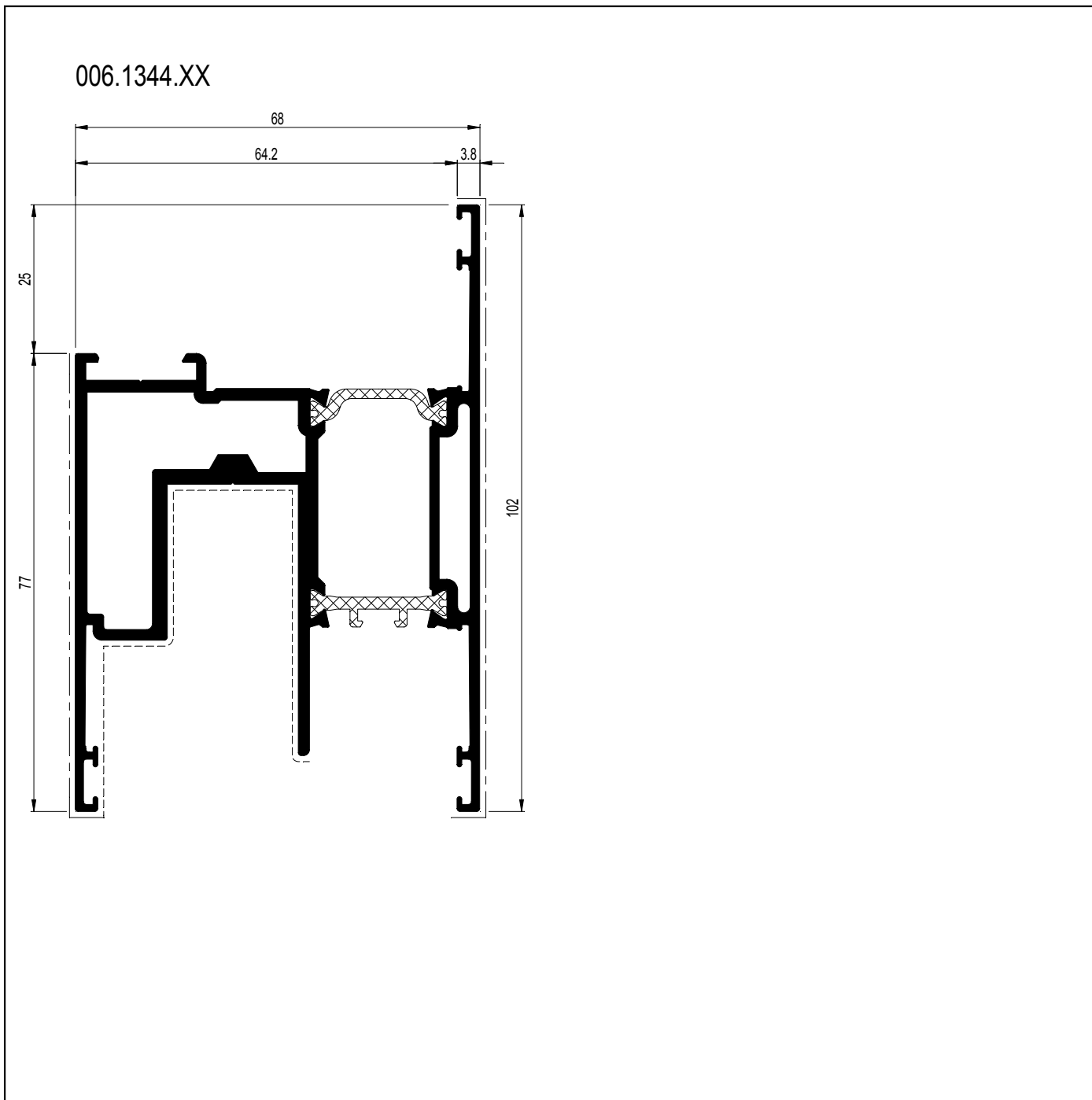

	006.1344.XX	
	068.7775.00	095.30PN.00 of-ou-or-oder 095.B500.00
	068.8835.00	097.0441.00
	068.8986.00	097.0374.00 of-ou-or-oder 097.0410.00 of-ou-or-oder 097.0463.00
	069.6569.04	---
	060.8723.-- (3x) or 060.8725.00 (3x)	---

Profielen
Profils
Profiles
Profile

34.C.022
02/2009

D0013852

CP 155 CP 155-LS

HULPPROFIELEN VLEUGEL
PROFILES DE RACCORDEMENT OUVRANT
ADDITIONAL PROFILES VENT
ZUSATZPROFILE FLUEGEL



	$\frac{A}{dm^2/m}$	$\frac{P}{dm^2/m}$	$\leftarrow L_m \rightarrow$	$I_x \text{ cm}^4$	$W_x \text{ cm}^3$	$a_x \text{ mm}$	$I_y \text{ cm}^4$	$W_y \text{ cm}^3$	$a_y \text{ mm}$	
006.0345.XX	37.55	8.6	4.00	25.726	5.732	42.12	2.647	1.572	16.84	Y — X X — Y 0
0U2.0202.XX	11.60	6.0	6.00	0.453	0.360	7.43	0.719	0.719	10.00	

006.0345.XX

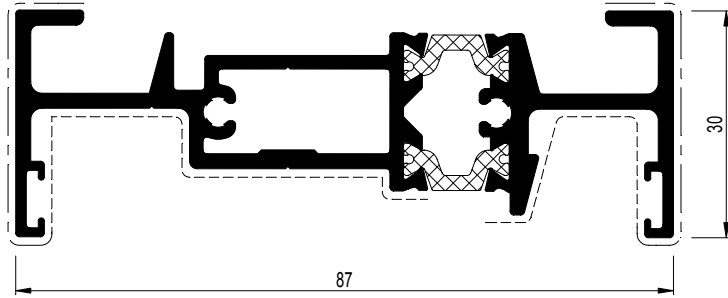

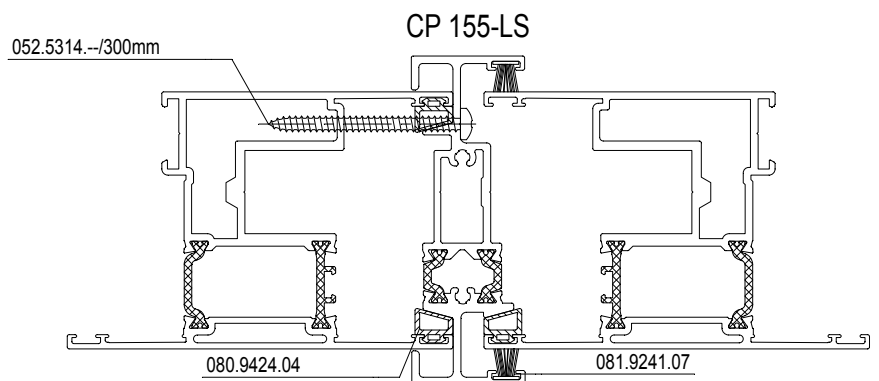
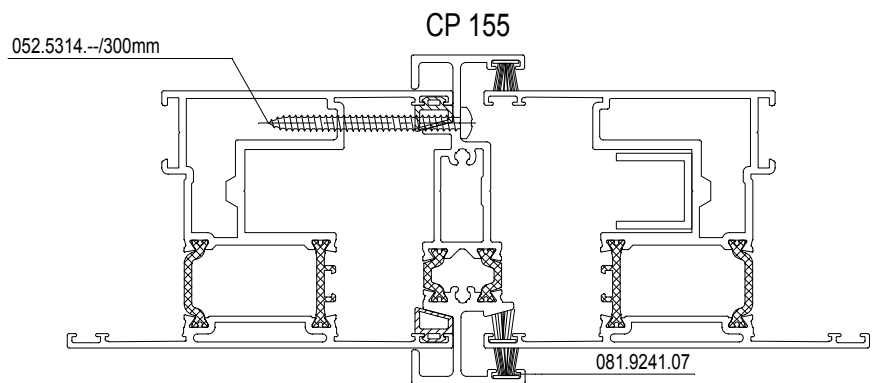
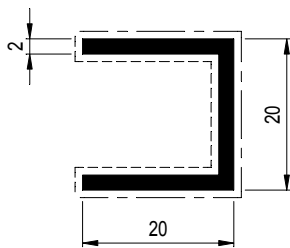

0U2.0202.XX



CP 155 CP 155-LS

HULPPROFIELEN VLEUGEL
PROFILES DE RACCORDEMENT OUVRANT
ADDITIONAL PROFILES VENT
ZUSATZPROFILE FLUEGEL



	$\frac{A}{dm^2/m}$	$\frac{P}{dm^2/m}$	L_m	$I_x \text{ cm}^4$	$W_x \text{ cm}^3$	ax mm	$I_y \text{ cm}^4$	$W_y \text{ cm}^3$	ay mm	
006.1341.04	-	-	6.00	1.437	0.633	11.03	6.678	1.913	25.19	
006.1342.XX	25.03	9.7	6.00	19.316	4.423	37.63	0.608	0.435	4.03	
006.1343.00	33.08	-	6.00	23.403	9.646	24.26	19.634	5.681	27.44	
0M0.1505.XX	4.00	4.0	6.00	0.140	0.187	7.50	0.015	0.062	2.50	

006.1342.XX

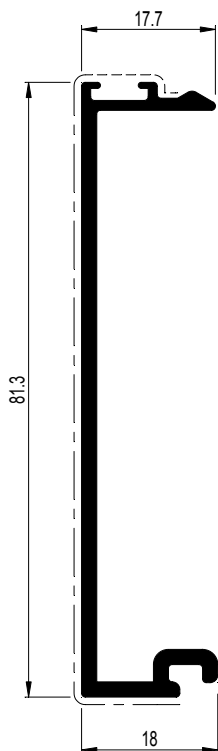

006.1343.00

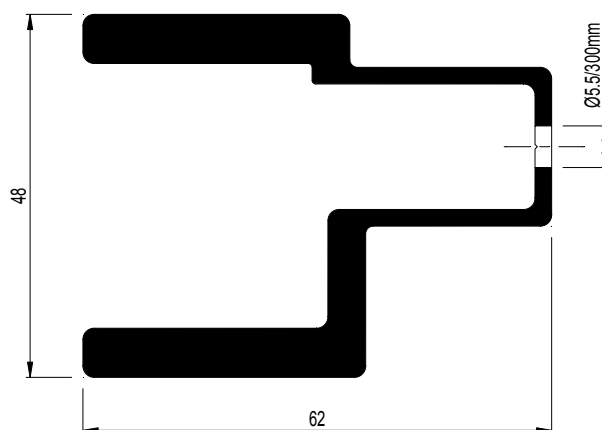

006.1341.04 (HPVC)

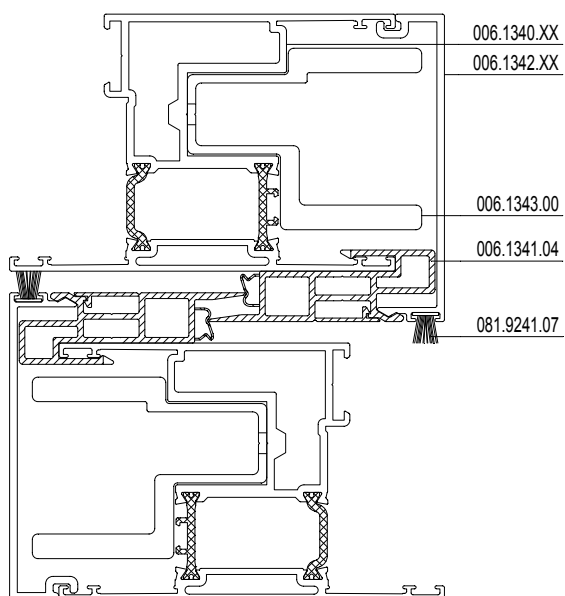
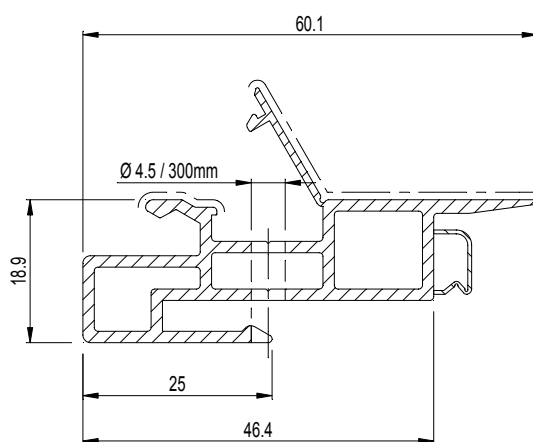

0M0.1505.XX

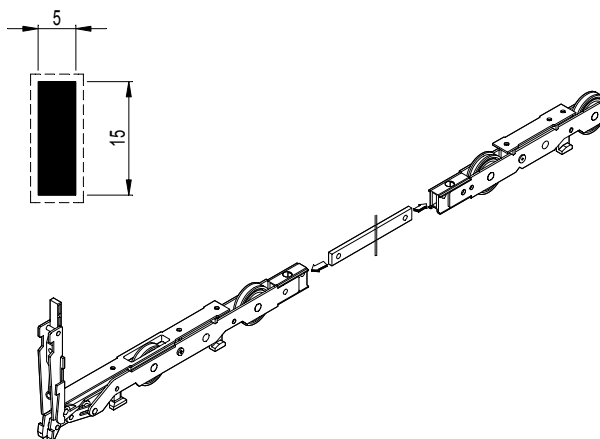

CP 155 CP 155-LS

VERSTERKINGSPROFIELEN VLEUGEL
PROFILES DE RENFORCEMENT OUVRANT
REINFORCEMENT PROFILES VENT
VERSTAERKUNGSPROFILE FLUEGEL

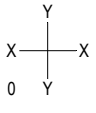

	$\frac{A}{dm^2/m}$	$\frac{P}{dm^2/m}$	L_m	$I_x \text{ cm}^4$	$W_x \text{ cm}^3$	$a_x \text{ mm}$	$I_y \text{ cm}^4$	$W_y \text{ cm}^3$	$a_y \text{ mm}$	
030.1097.00	-	-	7.00	10.260	3.656	28.06	4.477	2.763	16.20	
030.1098.00	-	-	7.00	19.656	6.418	25.35	6.287	3.880	16.20	
030.3099.XX	31.23	15.3	7.00	9.625	2.614	23.19	5.654	3.220	17.56	

030.3099.XX

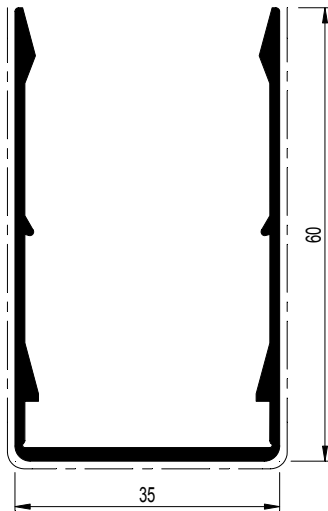

030.1097.00

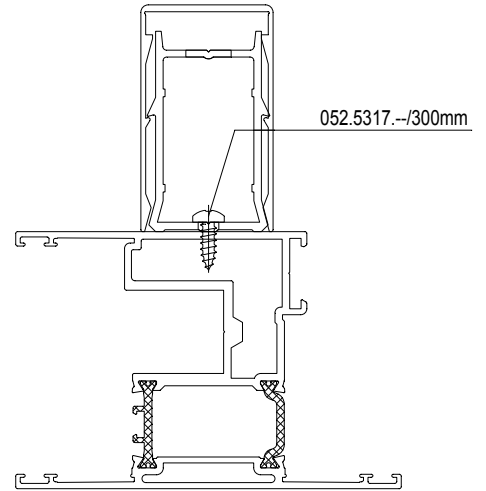
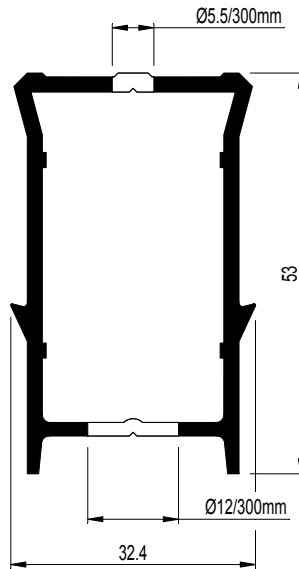

030.1098.00

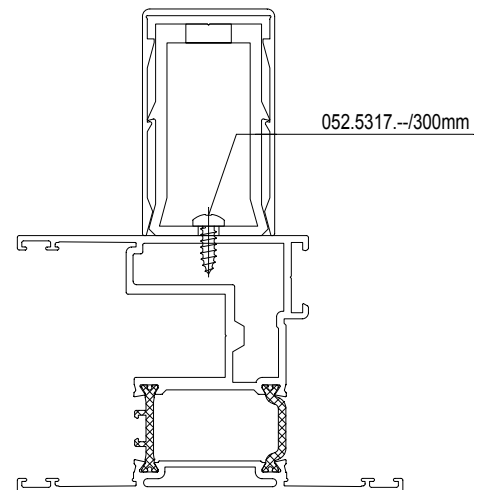
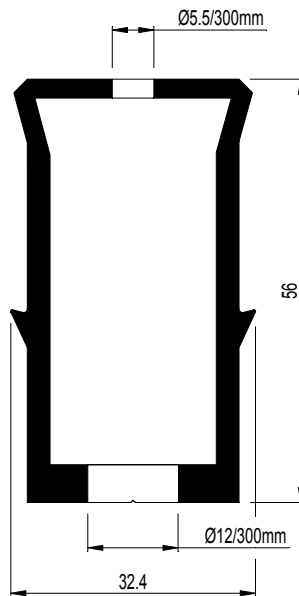

CP 155 CP 155-LS

T-PROFIELEN
TRAVERSES
TRANSOM-MULLIONS
SPROSSEN



	A dm ² /m	P dm ² /m	L_m	I_x cm ⁴	W_x cm ³	ax mm	I_y cm ⁴	W_y cm ³	ay mm	X Y X 0
008.3113.XX	34.24	11.0	7.00/5.00	16.916	4.166	27.40	8.602	2.264	38.00	
008.3120.XX	36.86	13.6	7.00/5.00	26.891	6.830	28.63	16.299	3.663	44.50	

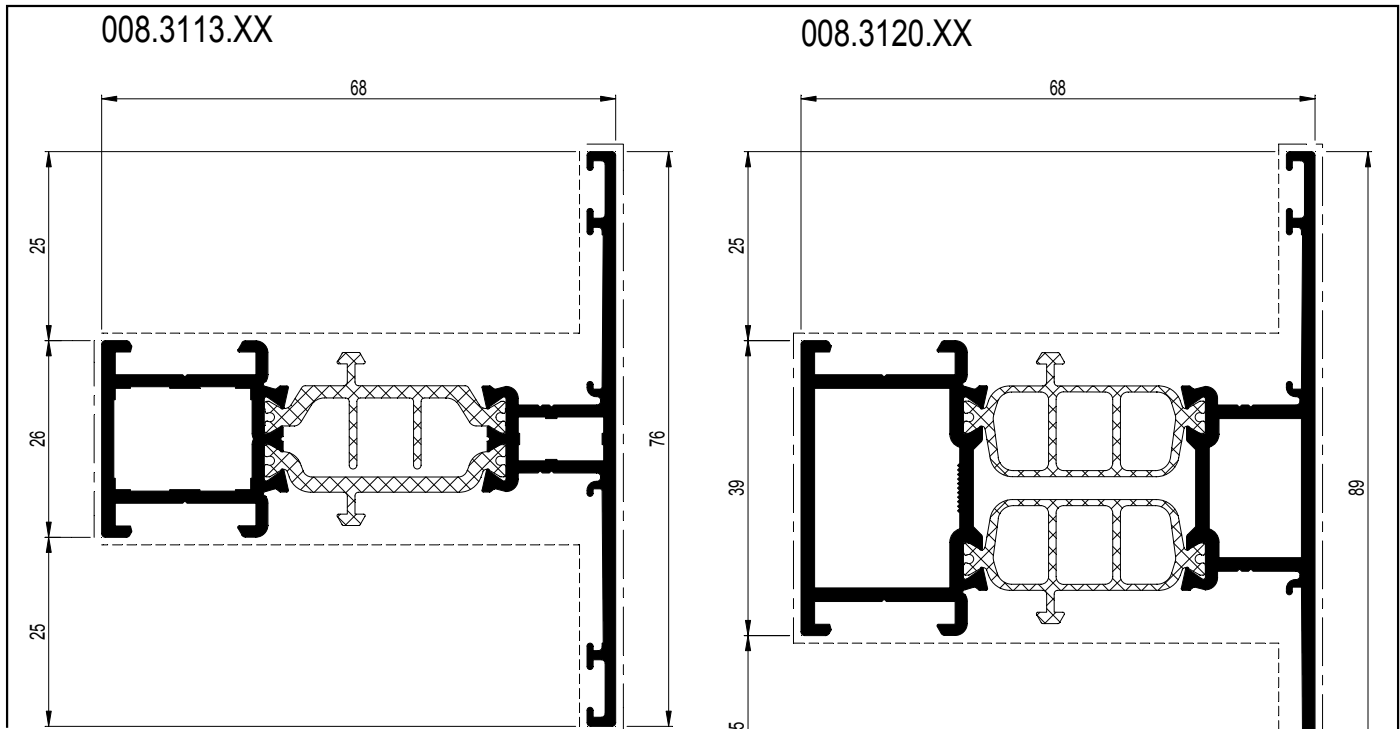

Icon	008.3113.XX	Icon	008.3120.XX
	068.7740.00		068.7852.00 + 068.7853.00
	068.8840.00		068.8841.00
	068.8730.00+(*) or 068.8740.00+(*) (*) 050.5153.--		068.8731.00+(*) or 068.8741.00+(*) (*) 050.5153.-- 2x
	068.8735.00 + 050.5153.--		068.8736.00 + 050.5153.-- (2x)
	068.8730.00+(*) or 068.8740.00+(*) (*) 068.5920.00		068.8731.00+(*) or 068.8741.00+(*) (*) 068.5920.00 (2x)
	068.8735.00 + 068.5920.00		068.8736.00 + 068.5920.00 (2x)
	068.8786.00		068.8787.00
	068.8883.00		068.8884.00
	060.8723.-- (2x) or 060.8725.00 (2x)		060.8723.-- (2x) or 060.8725.00 (2x)

Profielen
Profils
Profiles
Profile

34.C.026
02/2009

D0013856

CP 155 CP 155-LS

T-PROFIELEN
TRAVERSES
TRANSOM-MULLIONS
SPROSSEN



	$\frac{A}{dm^2/m}$	$\frac{P}{dm^2/m}$	L_m	$I_x \text{ cm}^4$	$W_x \text{ cm}^3$	$a_x \text{ mm}$	$I_y \text{ cm}^4$	$W_y \text{ cm}^3$	$a_y \text{ mm}$	X Y X 0
008.3123.XX	42.04	18.8	7.00	36.452	9.486	29.57	45.435	7.902	57.50	

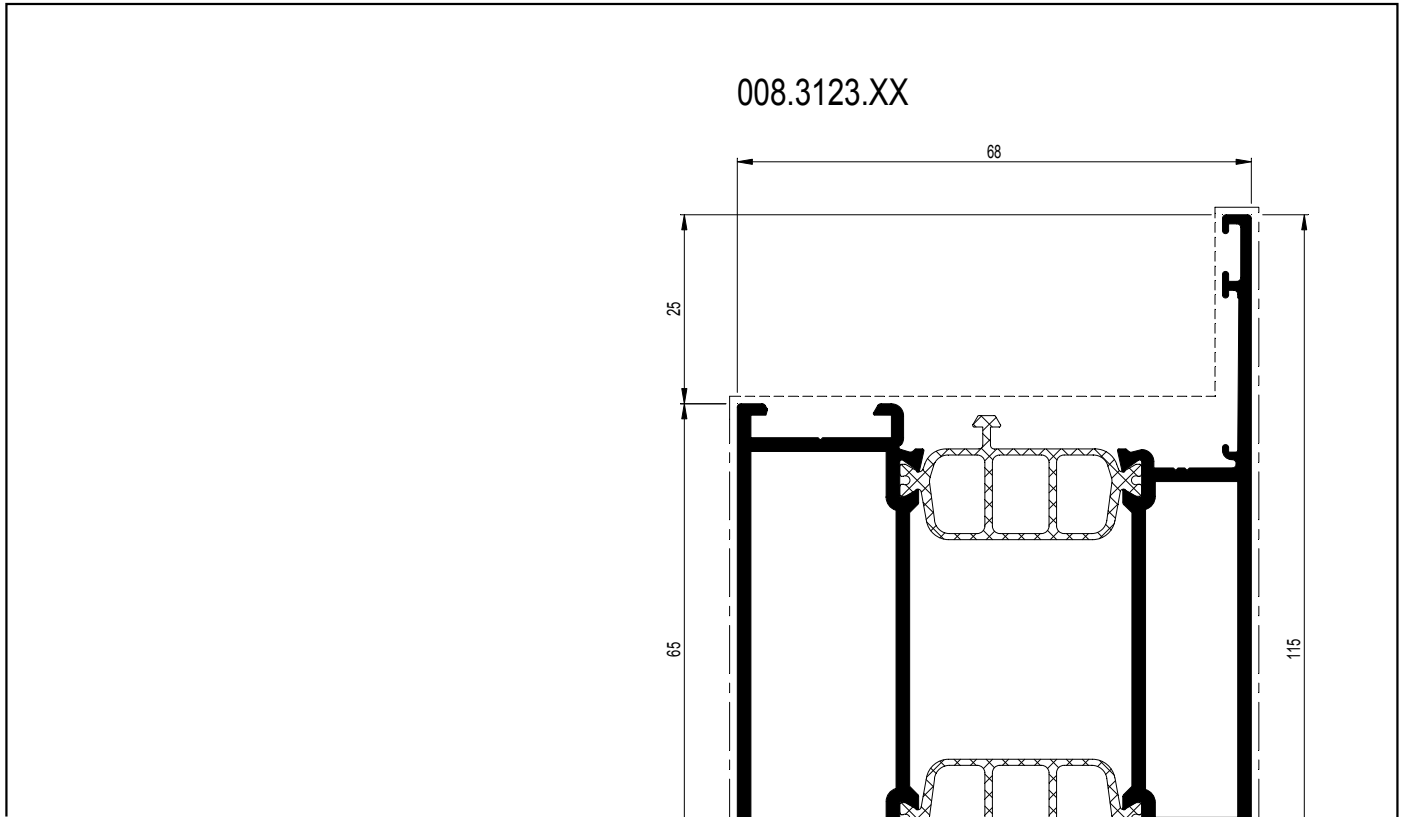

	008.3123.XX	
	068.7743.00	095.30PN.00 of-ou-or-oder 095.B500.00
	068.8843.00	097.O800.00 097.P100.00 097.P200.00 of-ou-or-oder 097.F900.00 of-ou-or-oder 097.0411.00
	068.8733.00+(*) or 068.8743.00+(*) (*) 050.5153.-- 2x	097.P800.00 097.P100.00 097.P200.00 of-ou-or-oder 097.F900.00 of-ou-or-oder 097.0410.00
	068.8738.00 + 050.5153.-- (2x)	097.P800.00 097.P100.00 097.P200.00 of-ou-or-oder 097.F900.00 of-ou-or-oder 097.0410.00
	068.8733.00+(*) or 068.8743.00+(*) (*) 068.5920.00 (2x)	097.P800.00 097.P100.00 097.P200.00 of-ou-or-oder 097.F900.00 of-ou-or-oder 097.0410.00
	068.8738.00 + 068.5920.00 (2x)	097.P800.00 097.P100.00 097.P200.00 of-ou-or-oder 097.F900.00 of-ou-or-oder 097.0410.00
	060.8723.-- (2x) or 060.8725.00 (2x)	---

Profielen
Perfilés
Profiles
Profile

34.C.027
02/2009

D0075003

CP 155 CP 155-LS

T-PROFIELEN
TRAVERSES
TRANSOM-MULLIONS
SPROSSEN



	A dm ² /m	P dm ² /m	L_m	I_x cm ⁴	W_x cm ³	a_x mm	I_y cm ⁴	W_y cm ³	a_y mm	X Y X 0
008.3114.XX	39.44	16.2	7.00	31.671	8.154	29.16	28.302	5.549	51.00	

008.3114.XX

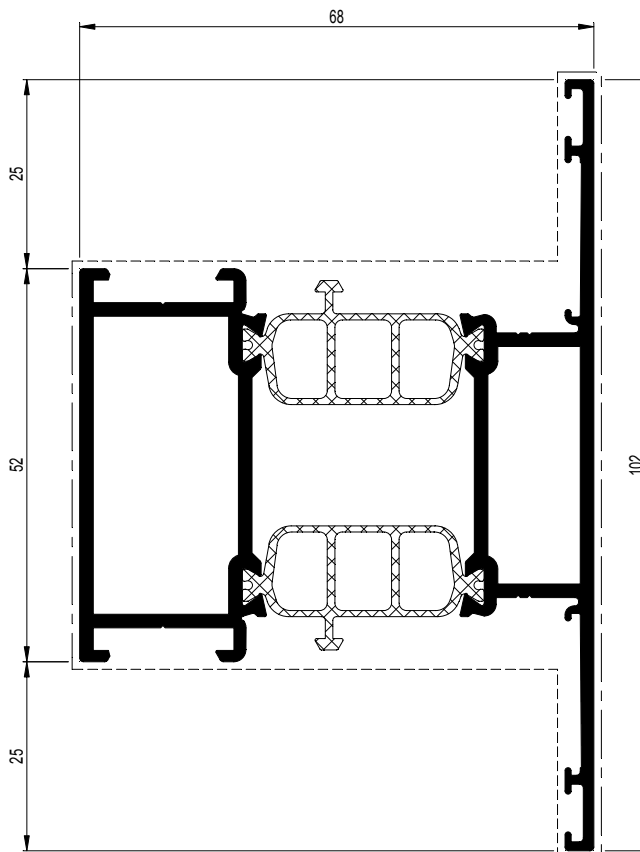

	008.3114.XX	
	068.7742.00	095.30PN.00 of-ou-or-oder 095.B500.00
	068.8842.00	097.O800.00 097.P100.00 097.P200.00 of-ou-or-oder 097.F900.00 of-ou-or-oder 097.0411.00
	068.8732.00+(*) or 068.8742.00+(*) (*) 050.5153.-- 2x	097.P800.00 097.P100.00 097.P200.00 of-ou-or-oder 097.F900.00 of-ou-or-oder 097.0410.00
	068.8737.00 + 050.5153.-- (2x)	097.P800.00 097.P100.00 097.P200.00 of-ou-or-oder 097.F900.00 of-ou-or-oder 097.0410.00
	068.8732.00+(*) or 068.8742.00+(*) (*) 068.5920.00 (2x)	097.P800.00 097.P100.00 097.P200.00 of-ou-or-oder 097.F900.00 of-ou-or-oder 097.0410.00
	068.8737.00 + 068.5920.00 (2x)	097.P800.00 097.P100.00 097.P200.00 of-ou-or-oder 097.F900.00 of-ou-or-oder 097.0410.00
	068.8788.00	097.0454.00
	068.8896.00	097.0461.00
	060.8723.-- (2x) or 060.8725.00 (2x)	---

Profielen
Profils
Profiles
Profile

34.C.028
02/2009

D0013857

CP 155 CP 155-LS

T-PROFIELEN
TRAVERSES
TRANSOM-MULLIONS
SPROSSEN



	$\frac{A}{dm^2/m}$	$\frac{P}{dm^2/m}$	$\leftarrow L_m \rightarrow$	$I_x \text{ cm}^4$	$W_x \text{ cm}^3$	$a_x \text{ mm}$	$I_y \text{ cm}^4$	$W_y \text{ cm}^3$	$a_y \text{ mm}$	X Y X 0
008.3824.XX	50.00	26.6	7.00	59.548	16.217	31.28	142.536	18.511	77.00	
OK8.3824.XX	50.00	26.3	1.15	59.548	16.217	31.28	142.536	18.511	77.00	

008.3824.XX L=7.00m

OK8.3824.XX L=1.15m

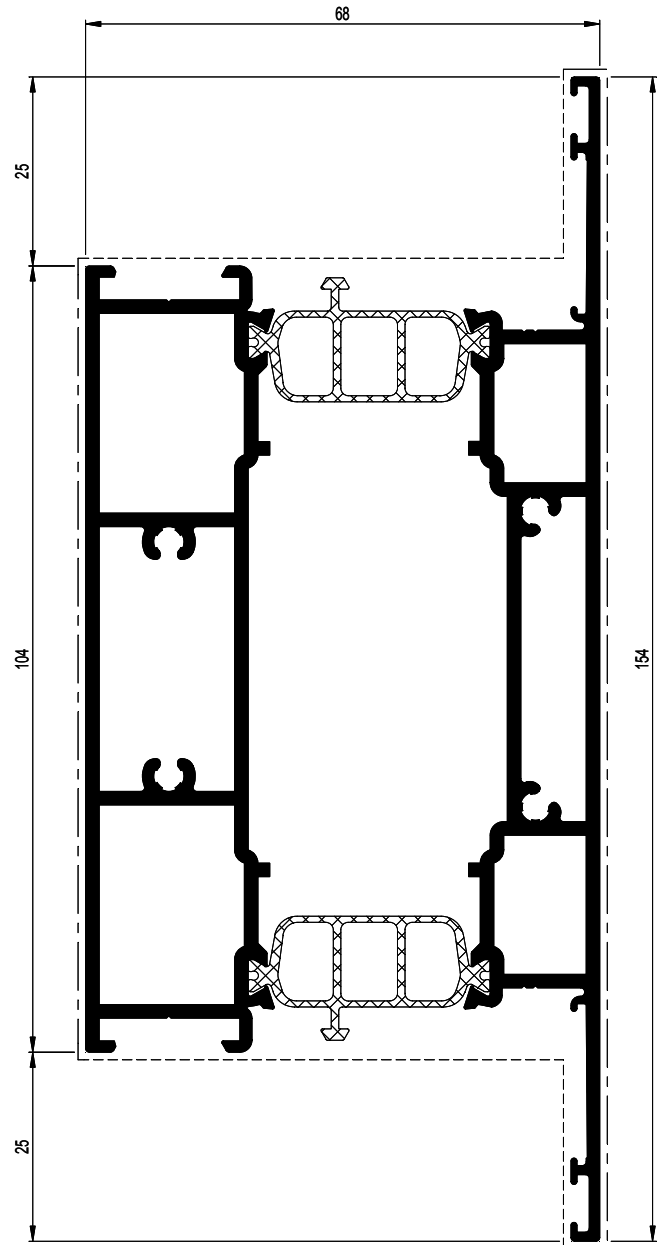

	008.3824.XX		OK8.3824.XX
	068.7852.00 (2x) + 068.7853.00 (2x)	---	068.7852.00 (2x) + 068.7853.00 (2x)
	068.8841.00 (2x)	097.O800.00 097.P100.00 097.P200.00 of-ou-or-oder 097.F900.00 of-ou-or-oder 097.0411.00	068.8841.00 (2x)
	052.5316.-- (4x)	---	052.5315.-- (4x)
	068.8734.00 + 050.5153.-- (2x)	097.P800.00 097.P100.00 097.P200.00 of-ou-or-oder 097.F900.00 of-ou-or-oder 097.0410.00	068.8734.00 + 050.5153.-- (2x)
	068.8739.00 + 050.5153.-- (2x)	097.P800.00 097.P100.00 097.P200.00 of-ou-or-oder 097.F900.00 of-ou-or-oder 097.0410.00	068.8739.00 + 050.5153.-- (2x)
	068.8734.-- + 068.5920.00 (2x)	097.P800.00 097.P100.00 097.P200.00 of-ou-or-oder 097.F900.00 of-ou-or-oder 097.0410.00	068.8734.-- + 068.5920.00 (2x)
	068.8739.00 + 068.5920.00 (2x)	097.P800.00 097.P100.00 097.P200.00 of-ou-or-oder 097.F900.00 of-ou-or-oder 097.0410.00	068.8739.00 + 068.5920.00 (2x)
	068.8787.00 (2x)	---	068.8787.00 (2x)
	068.8884.00 (2x)	---	068.8884.00 (2x)
	060.8723.-- (2x) or 060.8725.00 (2x)	---	060.8723.-- (2x) or 060.8725.00 (2x)

Profielen
Profils
Profiles
Profile

34.C.029
02/2009

D0013858

CP 155

WISSELPROFIEL
CHICANE
MEETING SECTION
WECHSELPROFIL



	A dm ² /m	P dm ² /m	L_m	I_x cm ⁴	W_x cm ³	ax mm	I_y cm ⁴	W_y cm ³	ay mm	Y X 0 Y
006.1346.XX	45.10	12.3	6.00	73.951	11.952	34.63	14.650	3.267	14.16	

006.1346.XX

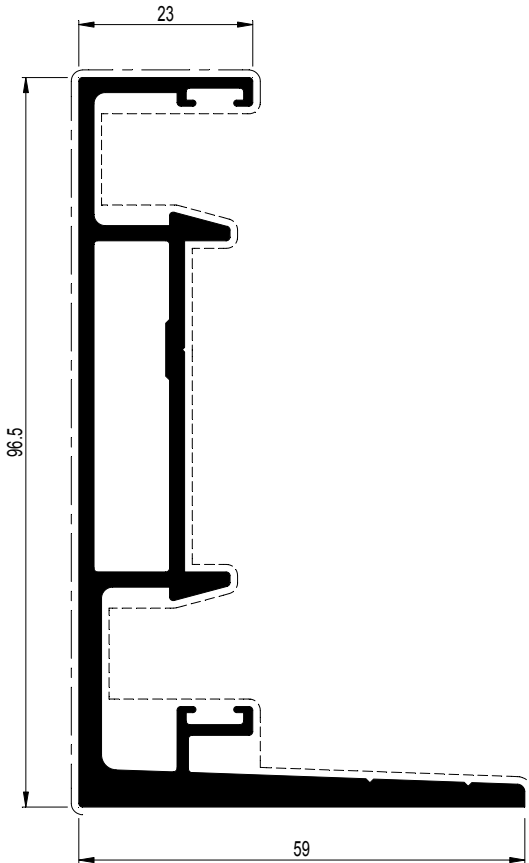

CP 155 CP 155-LS

GLASLATTEN
PARCLOSÉS
GLAZING BEADS
GLASLEISTEN

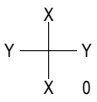

	$\frac{A}{dm^2/m}$	$\frac{P}{dm^2/m}$	$\leftarrow L_m \rightarrow$	$I_x \text{ cm}^4$	$W_x \text{ cm}^3$	ax mm	$I_y \text{ cm}^4$	$W_y \text{ cm}^3$	ay mm	
005.0276.XX	16.30	4.3	7.00	1.002	0.585	17.12	0.817	0.673	11.05	
030.3611.XX	16.93	4.9	7.00	0.875	0.690	12.67	1.076	0.609	17.69	
030.3612.XX	18.97	5.2	7.00	0.995	0.670	14.85	1.148	0.620	18.53	
030.3613.XX	19.57	5.5	7.00	1.192	0.696	17.13	1.184	0.629	18.81	
030.3614.XX	20.17	5.8	7.00	1.431	0.739	19.37	1.217	0.638	19.07	
030.3615.XX	20.86	6.1	7.00	1.750	0.821	21.31	1.252	0.647	19.35	

030.3611.XX

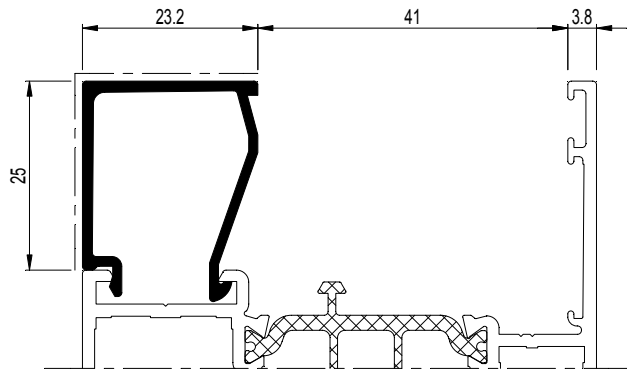

030.3614.XX

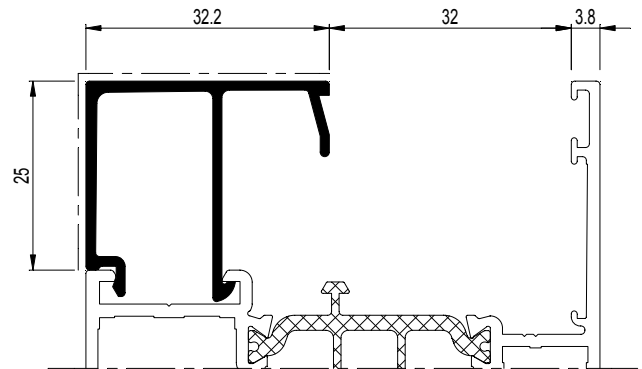

030.3612.XX

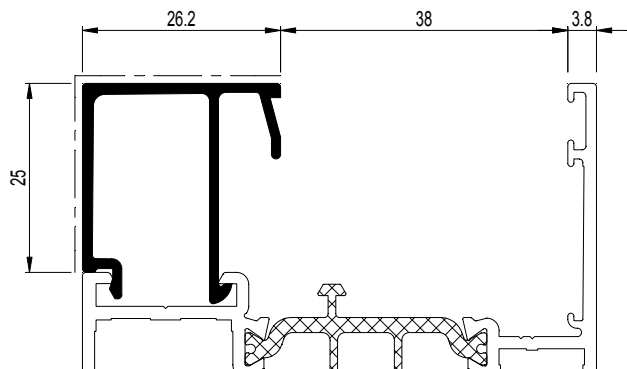

030.3615.XX

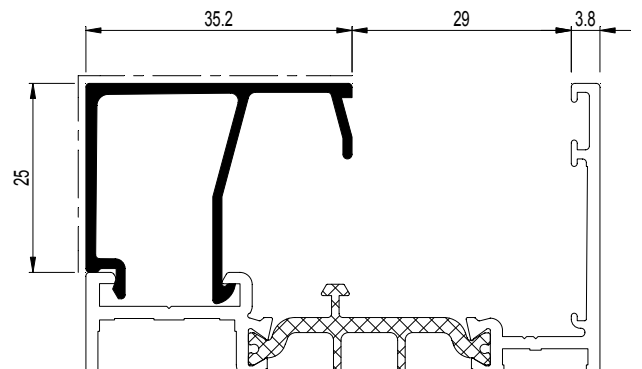

030.3613.XX

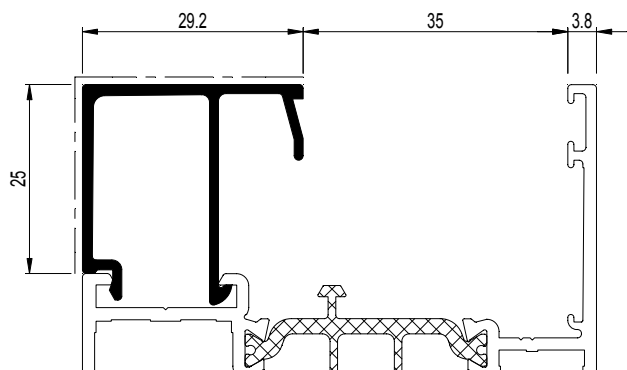

005.0276.XX

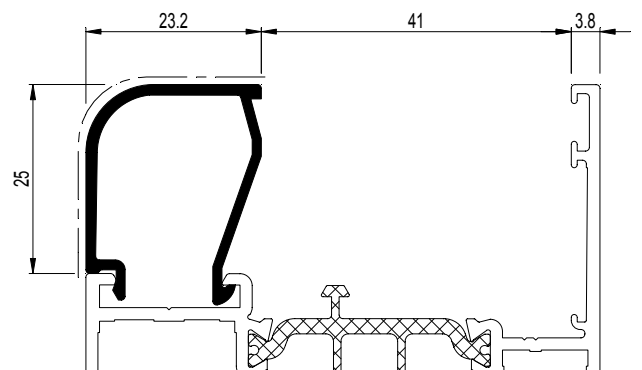

CP 155 CP 155-LS

GLASLATTEN
PARCLOSÉS
GLAZING BEADS
GLASLEISTEN

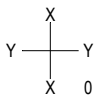

	A dm ² /m	P dm ² /m	L_m	I_x cm ⁴	W_x cm ³	a_x mm	I_y cm ⁴	W_y cm ³	a_y mm	
030.3200.XX	10.77	2.9	7.00	0.632	0.362	11.70	0.273	0.191	5.17	
030.3606.XX	12.37	3.4	7.00	0.277	0.198	13.99	0.919	0.612	14.14	
030.3607.XX	15.11	3.7	7.00	0.333	0.255	13.08	0.895	0.581	15.39	
030.3608.XX	15.10	4.0	7.00	0.431	0.354	12.15	0.914	0.560	16.34	
030.3609.XX	15.56	4.3	7.00	0.544	0.483	11.26	0.967	0.572	16.89	
030.3610.XX	16.19	4.6	7.00	0.691	0.646	10.70	1.022	0.590	17.32	

030.3200.XX

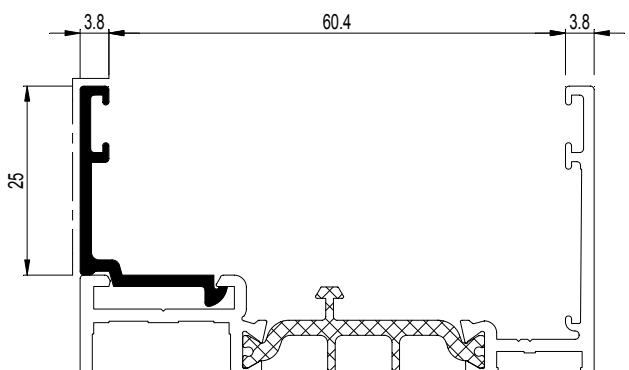

030.3608.XX

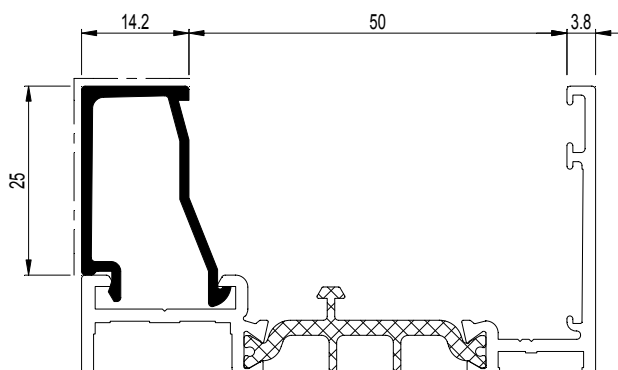

030.3606.XX

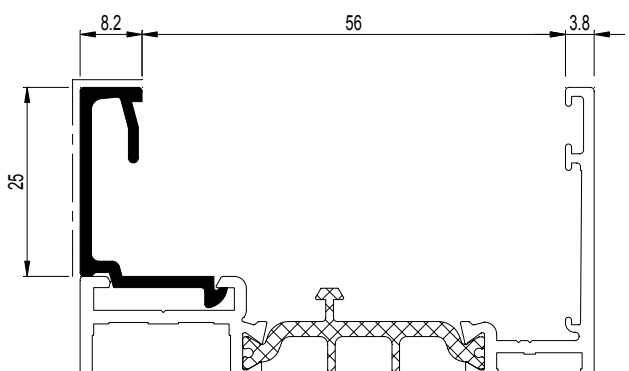

030.3609.XX

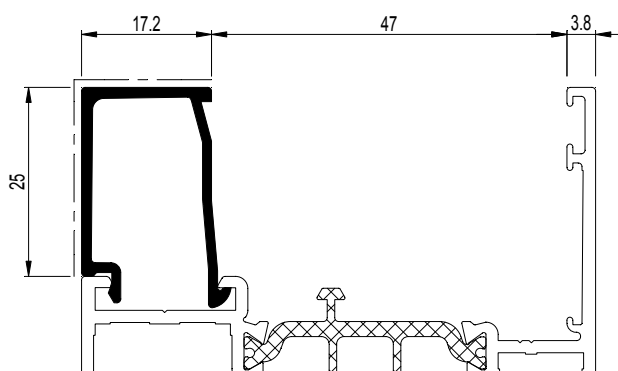

030.3607.XX

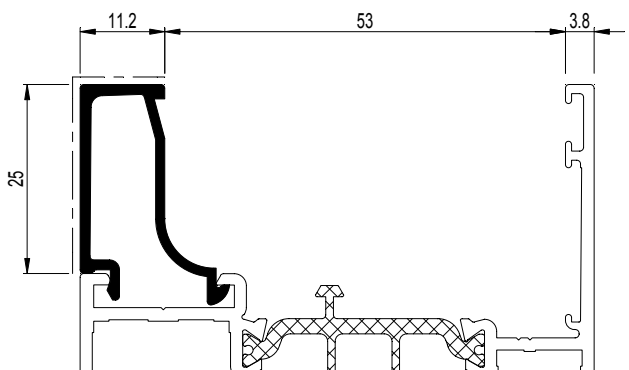

030.3610.XX

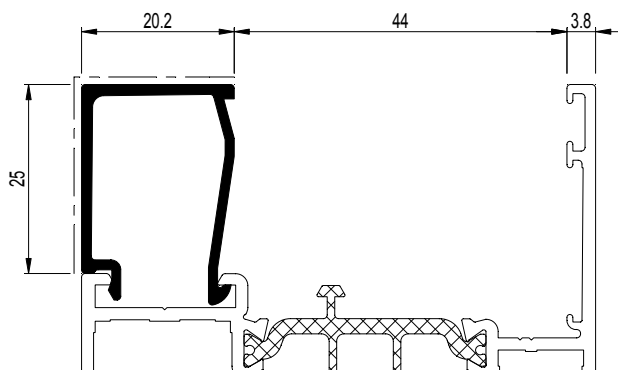

CP 155 CP 155-LS

INBRAAKWEREND
PROTECTION ANTI-VOL
BURGLAR PROTECTION
EINBRUCHHEMMEND

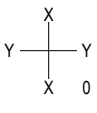

	$\frac{A}{dm^2/m}$	$\frac{P}{dm^2/m}$	$\leftarrow L_m \rightarrow$	$I_x \text{ cm}^4$	$W_x \text{ cm}^3$	$a_x \text{ mm}$	$I_y \text{ cm}^4$	$W_y \text{ cm}^3$	$a_y \text{ mm}$	
030.3648.XX	9.83	4.0	7.00	0.447	0.398	11.23	1.148	0.780	13.48	
030.3649.XX	9.94	4.3	7.00	0.548	0.520	10.55	1.211	0.857	14.13	
030.3650.XX	10.37	4.6	7.00	0.736	0.703	10.47	1.297	0.898	14.44	

030.3648.XX

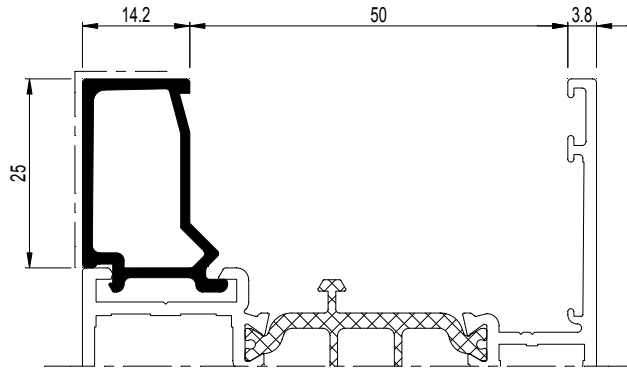

030.3650.XX

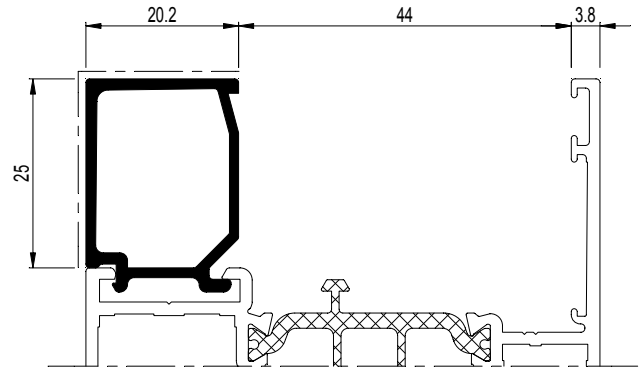

030.3649.XX

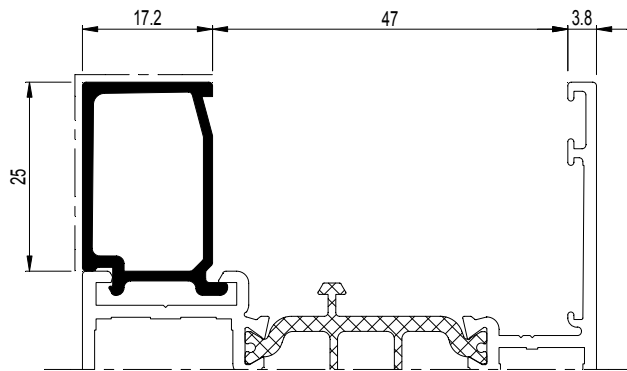

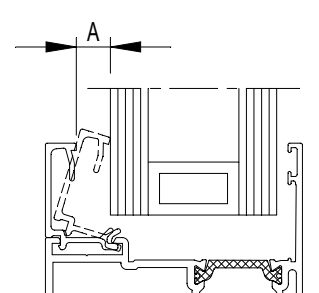
<ul style="list-style-type: none"> 030.3644.XX 030.3645.XX 030.3646.XX 030.3647.XX 030.3648.XX 030.3649.XX 030.3650.XX 	<p>A = min. 7mm</p>	
<ul style="list-style-type: none"> 030.3200.XX 030.3608.XX 030.3609.XX 030.3610.XX 030.3611.XX 030.3612.XX 030.3613.XX 030.3614.XX 030.3615.XX 030.3606.XX 030.3607.XX 005.0276.XX 	<p>A = min. 3mm</p>	

CP 155 CP 155-LS

INBRAAKWEREND
PROTECTION ANTI-VOL
BURGLAR PROTECTION
EINBRUCHHEMMEND



	A dm ² /m	P dm ² /m	L_m	I_x cm ⁴	W_x cm ³	a_x mm	I_y cm ⁴	W_y cm ³	a_y mm	X Y 0
030.3644.XX	10.24	2.8	7.00	0.291	0.213	13.64	0.560	0.299	9.46	
030.3645.XX	10.80	3.1	7.00	0.293	0.213	13.79	0.737	0.423	10.79	
030.3646.XX	13.06	3.4	7.00	0.296	0.219	13.52	0.957	0.618	12.72	
030.3647.XX	9.74	3.7	7.00	0.376	0.315	11.94	1.072	0.699	12.86	

080.9103.SY

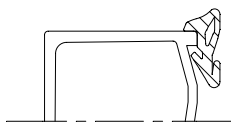

080.9114.SY

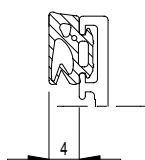

030.3644.XX

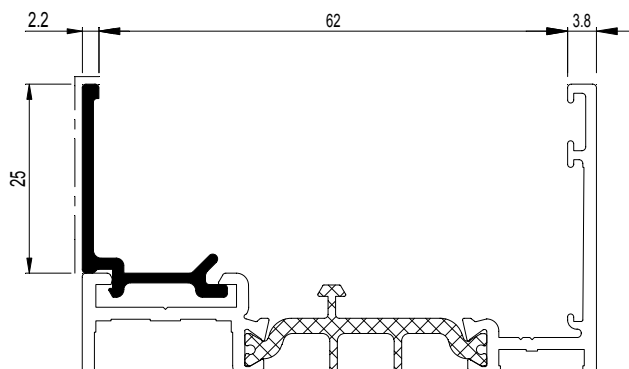

080.8904.SY

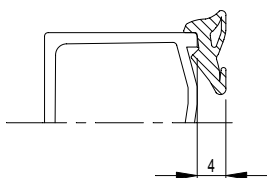

080.9116.04

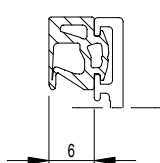

080.9105.SY

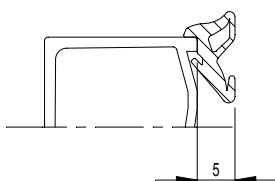

080.9118.04

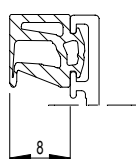

030.3645.XX

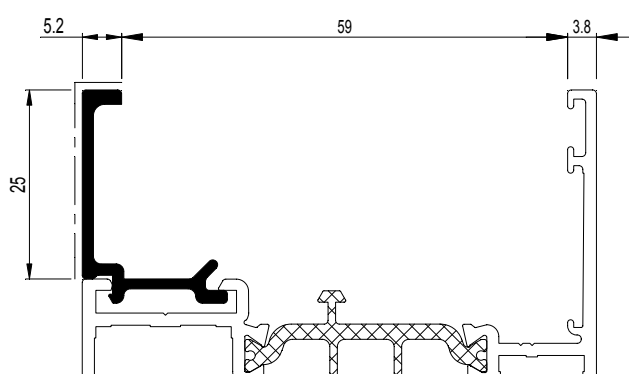

080.9106.SY

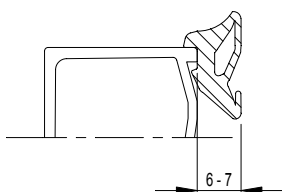

080.9108.04

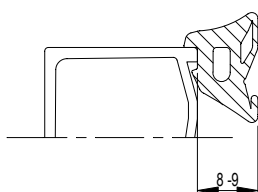

030.3647.XX

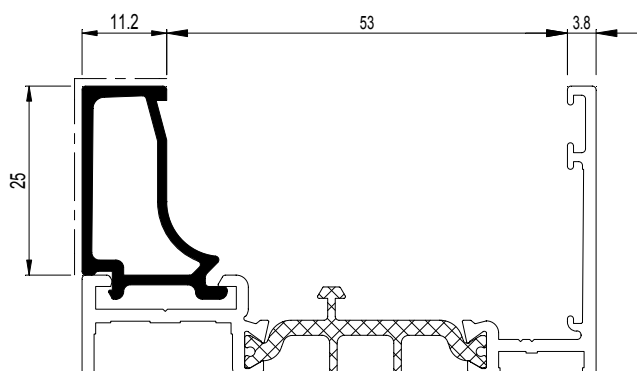

030.3646.XX

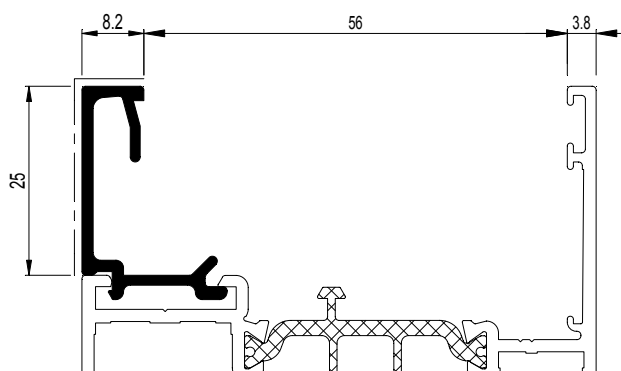

Glaslat Parclose Glazing bead Glasleiste	Beglazingsrubber binnen Joint de vitrage intérieur Glazing gasket inside Verglasungsdichtung innen	Glasdikte Epaisseur de vitrage Glazing thickness Glasdicke	Beglazingsrubber buiten Joint de vitrage extérieur Glazing gasket outside Verglasungsdichtung außen	Glaslat Parclose Glazing bead Glasleiste	Beglazingsrubber binnen Joint de vitrage intérieur Glazing gasket inside Verglasungsdichtung innen	Glasdikte Epaisseur de vitrage Glazing thickness Glasdicke	Beglazingsrubber buiten Joint de vitrage extérieur Glazing gasket outside Verglasungsdichtung außen
030.3615.XX	080.9108.04	13	080.9118.04	005.0276.XX	080.9108.04	24	080.9118.04
030.3615.XX	080.9106.SY	14	080.9118.04	005.0276.XX	080.9108.04	25	080.9118.04
030.3615.XX	080.9108.04	15	080.9116.04	005.0276.XX	080.9108.04	26	080.9116.04
030.3615.XX	080.9106.SY	16	080.9116.04	005.0276.XX	080.9108.04	27	080.9116.04
030.3615.XX	080.9108.04	17	080.9114.SY	005.0276.XX	080.9108.04	28	080.9114.SY
030.3615.XX	080.9106.SY	18	080.9114.SY	005.0276.XX	080.9108.04	29	080.9114.SY
030.3615.XX	080.9106.SY	19	080.9114.SY	005.0276.XX	080.9106.SY	30	080.9114.SY
030.3615.XX	080.9105.SY	20	080.9114.SY	005.0276.XX	080.9106.SY	31	080.9114.SY
030.3615.XX	080.8904.SY	21	080.9114.SY	005.0276.XX	080.9105.SY	32	080.9114.SY
030.3614.XX	080.9106.SY	22	080.9114.SY	005.0276.XX	080.9105.SY	33	080.9114.SY
030.3614.XX	080.9105.SY	23	080.9114.SY	005.0276.XX	080.8904.SY	33	080.9114.SY
030.3614.XX	080.8904.SY	24	080.9114.SY	005.0276.XX	080.9103.SY	34	080.9114.SY
030.3613.XX	080.9106.SY	25	080.9114.SY				
030.3613.XX	080.9105.SY	26	080.9114.SY				
030.3613.XX	080.8904.SY	27	080.9114.SY				
030.3612.XX	080.9106.SY	28	080.9114.SY				
030.3612.XX	080.9105.SY	29	080.9114.SY				
030.3612.XX	080.8904.SY	30	080.9114.SY				
030.3611.XX	080.9106.SY	31	080.9114.SY				
030.3611.XX	080.9105.SY	32	080.9114.SY				
030.3611.XX	080.8904.SY	33	080.9114.SY				
030.3610.XX	080.9106.SY	34	080.9114.SY				
030.3610.XX	080.9105.SY	35	080.9114.SY				
030.3610.XX	080.8904.SY	36	080.9114.SY				
030.3609.XX	080.9106.SY	37	080.9114.SY				
030.3609.XX	080.9105.SY	38	080.9114.SY				
030.3609.XX	080.8904.SY	39	080.9114.SY				
030.3608.XX	080.9106.SY	40	080.9114.SY				
030.3608.XX	080.9105.SY	41	080.9114.SY				
030.3608.XX	080.8904.SY	42	080.9114.SY				
030.3607.XX	080.9106.SY	43	080.9114.SY				
030.3607.XX	080.9105.SY	44	080.9114.SY				
030.3607.XX	080.8904.SY	45	080.9114.SY				
030.3606.XX	080.9106.SY	46	080.9114.SY				
030.3606.XX	080.9105.SY	47	080.9114.SY				
030.3606.XX	080.8904.SY	48	080.9114.SY				
030.3200.XX	080.9108.04	49	080.9114.SY				
030.3200.XX	080.9108.04	50	080.9114.SY				
030.3200.XX	080.9106.SY	51	080.9114.SY				
030.3200.XX	080.9105.SY	52	080.9114.SY				

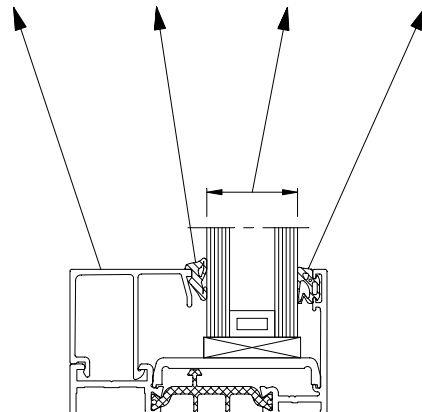
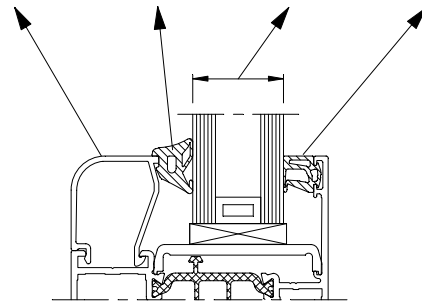

Glaslat Parcose Glazing bead Glasleiste	Beglazingsrubber binnen Joint de vitrage intérieur Glazing gasket inside Verglasungsdichtung innen	Glasdikte Epaisseur de vitrage Glazing thickness Glasdicke	Beglazingsrubber buiten Joint de vitrage extérieur Glazing gasket outside Verglasungsdichtung außen
030.3650.XX	080.9108.04	27	080.9118.04
030.3650.XX	080.9108.04	28	080.9118.04
030.3650.XX	080.9106.SY	29	080.9118.04
030.3650.XX	080.9108.04	30	080.9116.04
030.3650.XX	080.9108.04	31	080.9116.04
030.3650.XX	080.9108.04	32	080.9114.SY
030.3650.XX	080.9106.SY	33	080.9114.SY
030.3649.XX	080.9108.04	34	080.9116.04
030.3649.XX	080.9108.04	35	080.9114.SY
030.3649.XX	080.9106.SY	36	080.9114.SY
030.3648.XX	080.9108.04	37	080.9114.SY
030.3648.XX	080.9108.04	38	080.9114.SY
030.3647.XX	080.9108.04	39	080.9114.SY
030.3647.XX	080.9108.04	40	080.9114.SY
030.3647.XX	080.9108.04	41	080.9114.SY
030.3647.XX	080.9106.SY	42	080.9114.SY
030.3646.XX	080.9108.04	43	080.9114.SY
030.3646.XX	080.9108.04	44	080.9114.SY
030.3646.XX	080.9106.SY	45	080.9114.SY
030.3645.XX	080.9108.04	46	080.9114.SY
030.3645.XX	080.9108.04	47	080.9114.SY
030.3645.XX	080.9106.SY	48	080.9114.SY
030.3644.XX	080.9108.04	49	080.9114.SY
030.3644.XX	080.9108.04	50	080.9114.SY
030.3644.XX	080.9106.SY	51	080.9114.SY

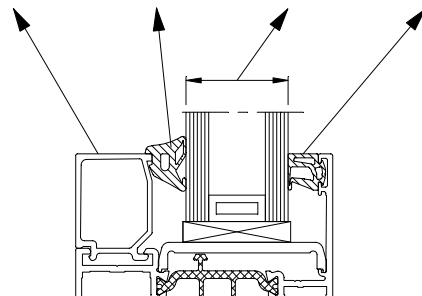

CP 155 CP 155-LS

ROLLUIKGELEIDERS
GUIDES A VOLET
SHUTTER GUIDES
ROLLADENFUEHRUNGEN



	A dm ² /m	P dm ² /m	L_m	I_x cm ⁴	W_x cm ³	a_x mm	I_y cm ⁴	W_y cm ³	a_y mm	
004.3130.XX	19.05	1.6	6.00	1.141	0.774	27.84	1.881	0.675	11.18	
004.3843.XX	23.68	8.0	6.00	4.009	1.264	10.47	1.621	0.952	15.29	
030.1143.XX	22.89	7.8	6.00	3.495	1.143	14.53	2.214	1.076	20.57	

004.3130.XX

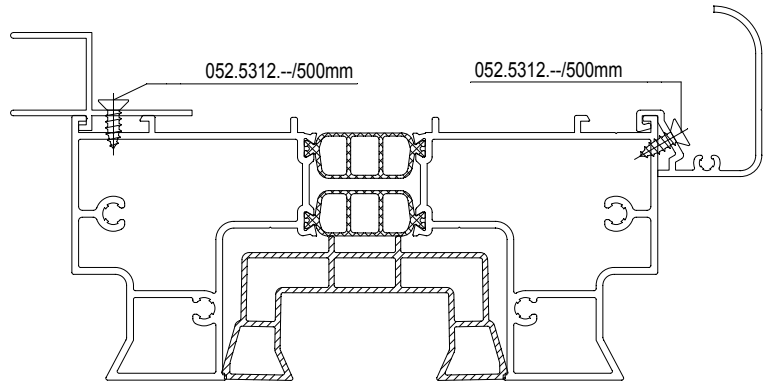
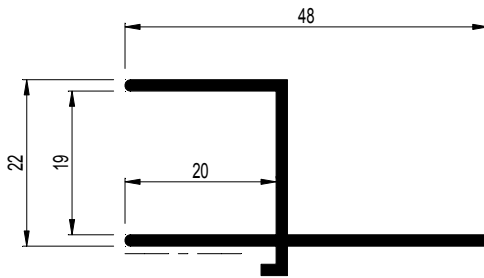

030.1143.XX

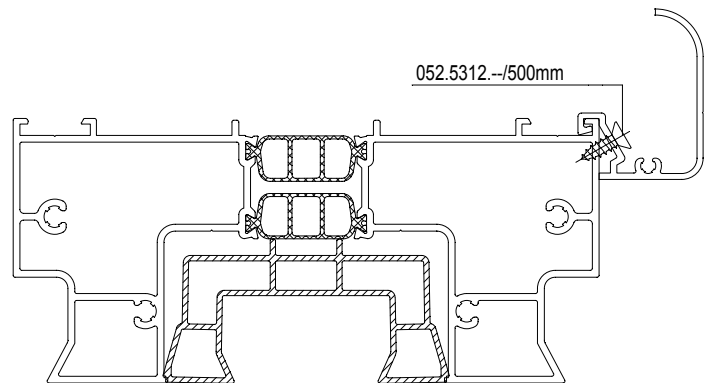
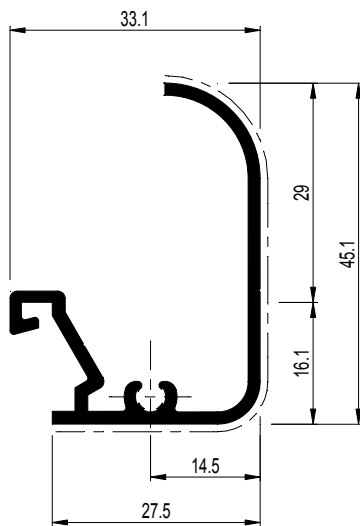

004.3843.XX

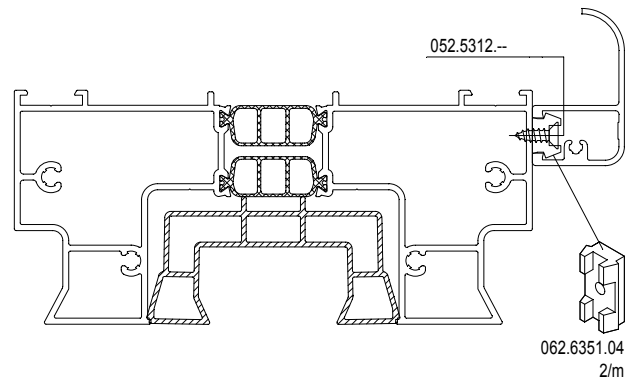
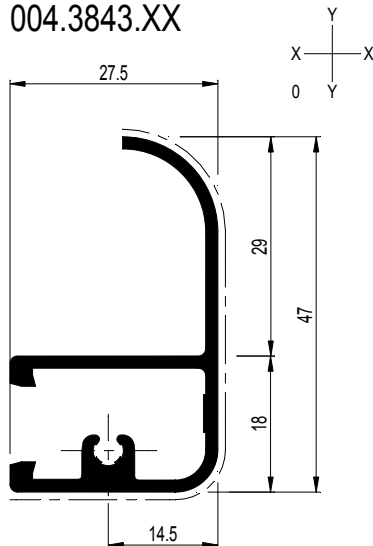

CP 155 CP 155-LS

ROLLUIKGELEIDERS
GUIDES A VOLET
SHUTTER GUIDES
ROLLADENFUEHRUNGEN



	A dm ² /m	P dm ² /m	L_m	I_x cm ⁴	W_x cm ³	a_x mm	I_y cm ⁴	W_y cm ³	a_y mm	
004.3167.XX	35.96	12.8	6.00	9.873	3.327	28.51	3.238	2.151	12.95	
030.1142.XX	35.19	7.0	6.00	13.153	3.911	31.19	3.015	1.909	15.79	

004.3167.XX

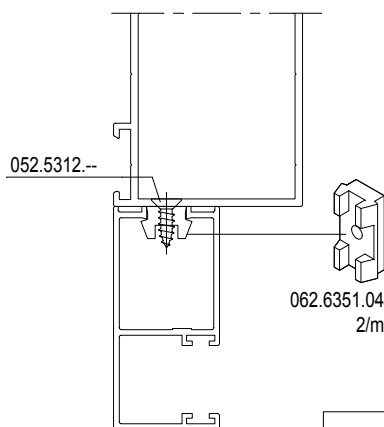
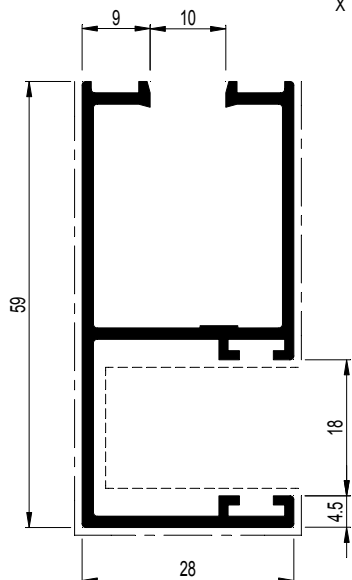

081.9092.04	081.9092.04	10mm
081.9092.04	081.9091.04	12mm
081.9091.04	081.9091.04	14mm
081.9091.04	-	16mm

030.1142.XX

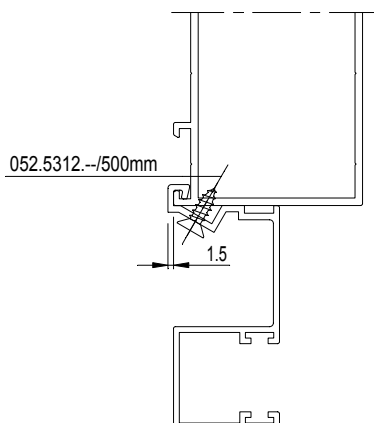
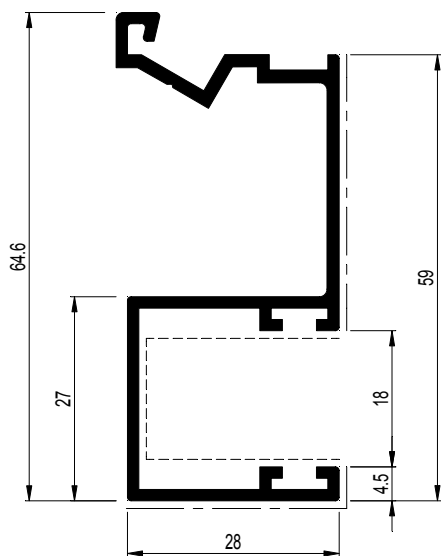

CP 155 CP 155-LS

DILATATIEPROFIEL
PROFIE DE DILATATION
EXPANSION PROFILE
AUSDEHNUNGSPROFIL



	$\frac{A}{dm^2/m}$	$\frac{P}{dm^2/m}$	L_m	$I_x \text{ cm}^4$	$W_x \text{ cm}^3$	$a_x \text{ mm}$	$I_y \text{ cm}^4$	$W_y \text{ cm}^3$	$a_y \text{ mm}$	Y X 0 Y
030.0080.XX	18.20	2.9	7.00	0.522	0.470	11.12	0.979	0.633	14.05	

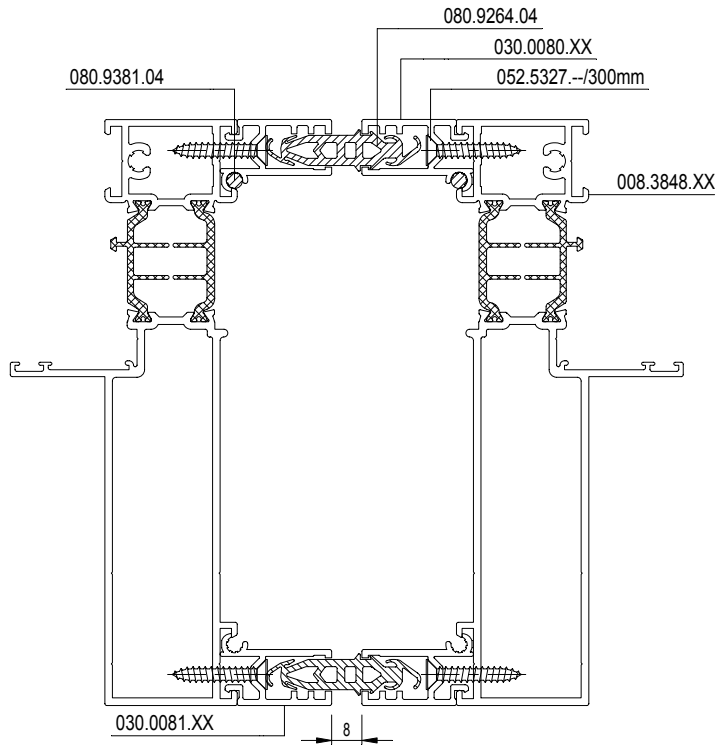
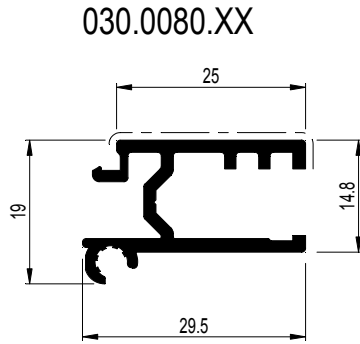

CP 155 CP 155-LS

KOPPELPROFIEL
PROFLE DE RACCORDEMENT
CONNECTION PROFILE
KUPPLUNGSPROFIL



	A dm ² /m	P dm ² /m	L_m	I_x cm ⁴	W_x cm ³	ax mm	I_y cm ⁴	W_y cm ³	ay mm	Y X 0 Y
008.3848.XX	49.15	18.7	7.00	163.672	20.376	80.33	16.564	4.166	20.24	

008.3848.XX

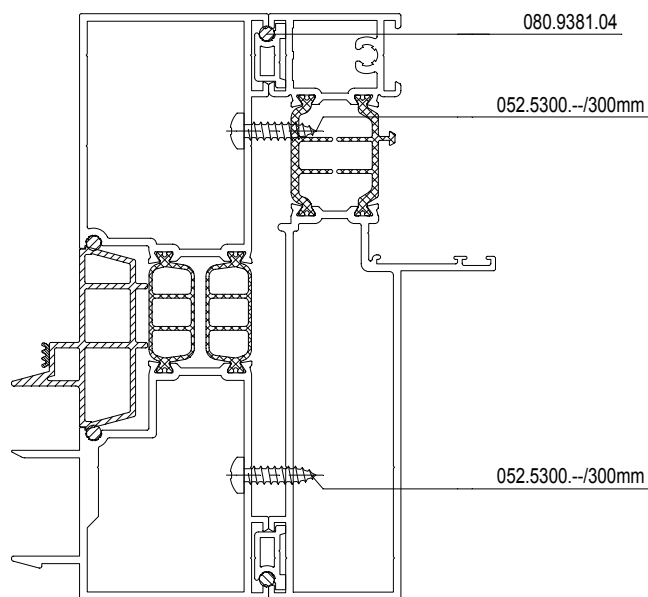
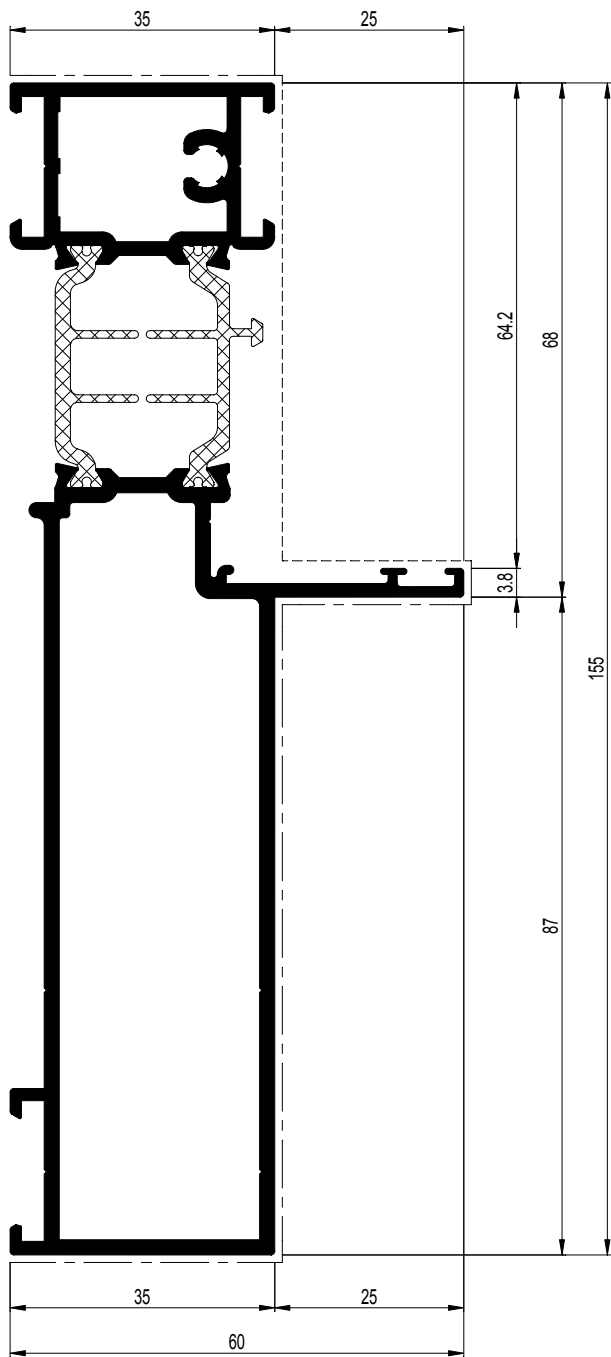

	008.3848.XX	
	068.7633.00	--
	060.8723.-- (or) 060.8725.00	--

Profielen
Profils
Profiles
Profile

34.C.040
02/2009

D0075000

CP 155 CP 155-LS

HULPPROFIELEN
PROFILES DE RACCORDEMENT
ADDITIONAL PROFILES
ZUSATZPROFILE



	$\frac{A}{dm^2/m}$	$\frac{P}{dm^2/m}$	$\leftarrow L_m \rightarrow$	$I_x \text{ cm}^4$	$W_x \text{ cm}^3$	$a_x \text{ mm}$	$I_y \text{ cm}^4$	$W_y \text{ cm}^3$	$a_y \text{ mm}$	
006.0371.XX	36.54	23.6	7.00	120.097	15.082	75.37	4.145	3.255	12.73	X 0 Y
030.0138.00	-	-	7.00	0.043	0.102	4.01	0.150	0.174	8.39	0 Y

006.0371.XX

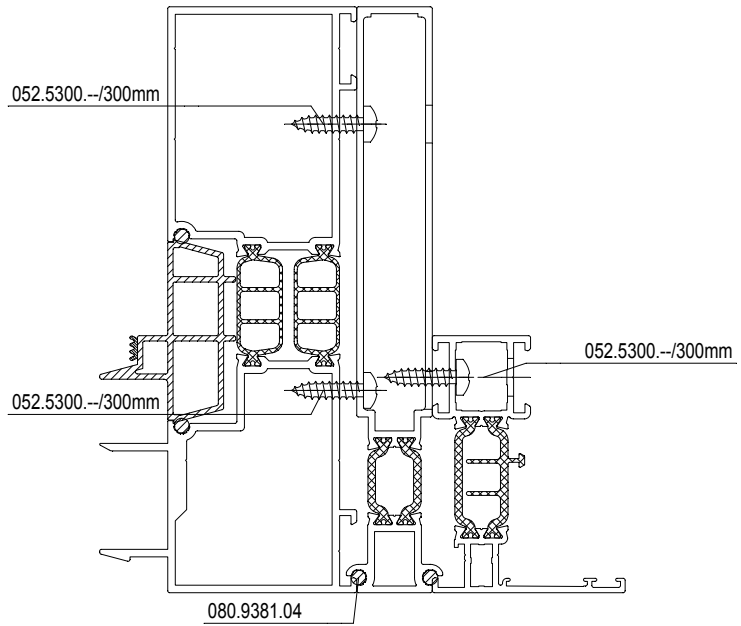
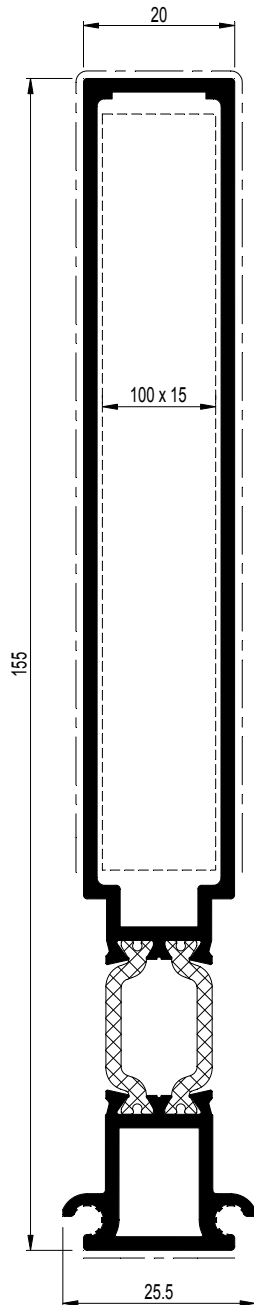

030.0138.00

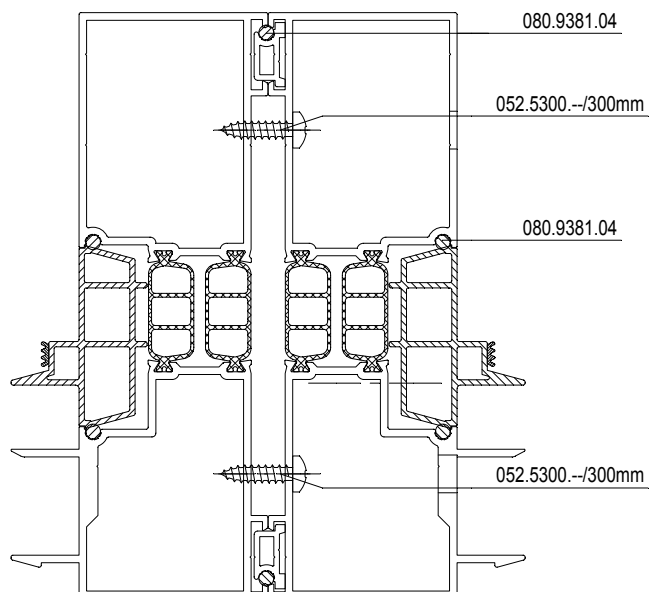
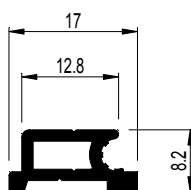

CP 155 CP 155-LS

HULPPROFIELEN
PROFILES DE RACCORDEMENT
ADDITIONAL PROFILES
ZUSATZPROFILE

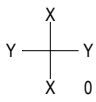

	A dm ² /m	P dm ² /m	L_m	I_x cm ⁴	W_x cm ³	a_x mm	I_y cm ⁴	W_y cm ³	a_y mm	
006.0370.XX	45.15	5.3	7.00	147.133	18.107	71.65	5.660	1.431	39.55	Y — X — X 0
009.1886.XX	18.47	3.1	7.00	0.884	0.812	9.31	3.914	1.307	20.07	
043.1028.XX	9.59	2.3	6.00	-	-	-	-	-	-	

006.0370.XX

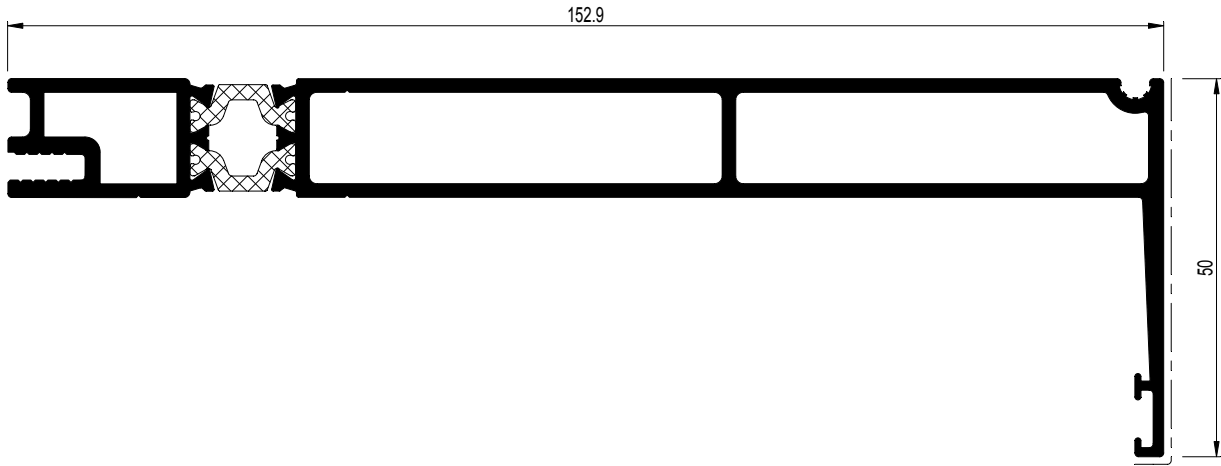

009.1886.XX

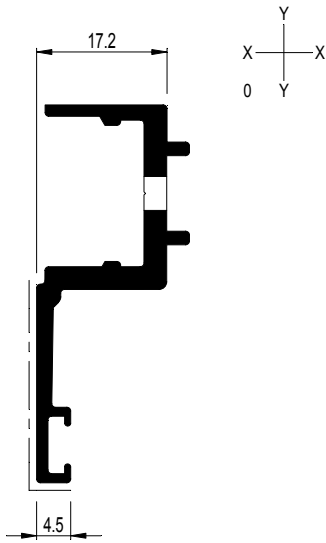

043.1028.XX

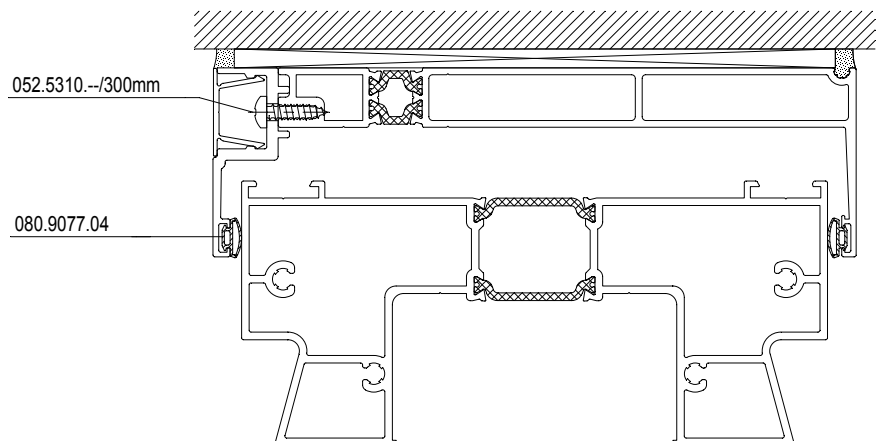
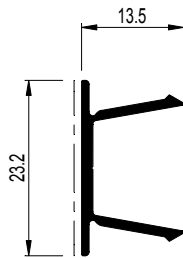

CP 155 CP 155-LS

HULPPROFIELEN
PROFILES DE RACCORDEMENT
ADDITIONAL PROFILES
ZUSATZPROFILE

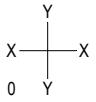

	$\frac{A}{dm^2/m}$	$\frac{P}{dm^2/m}$	L_m	$I_x \text{ cm}^4$	$W_x \text{ cm}^3$	$a_x \text{ mm}$	$I_y \text{ cm}^4$	$W_y \text{ cm}^3$	$a_y \text{ mm}$	
030.3370.XX	11.80	2.4	7.00	0.253	0.197	5.14	0.640	0.342	18.69	X Y
030.3890.XX	18.33	2.8	7.00	0.682	0.648	7.58	1.066	0.765	13.93	0 Y

030.3370.XX

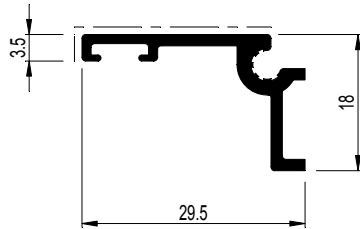

030.3890.XX

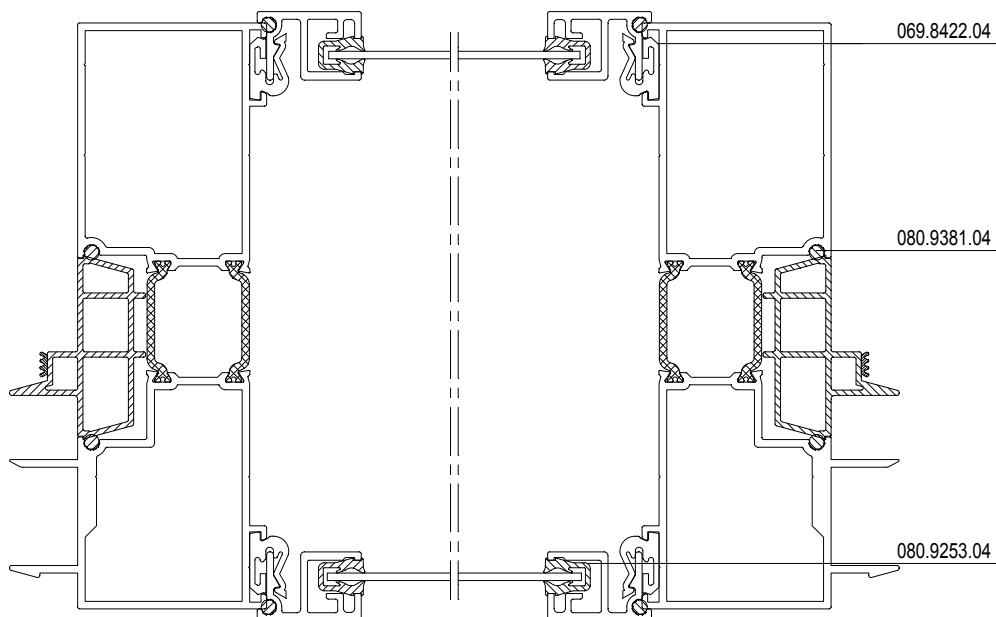
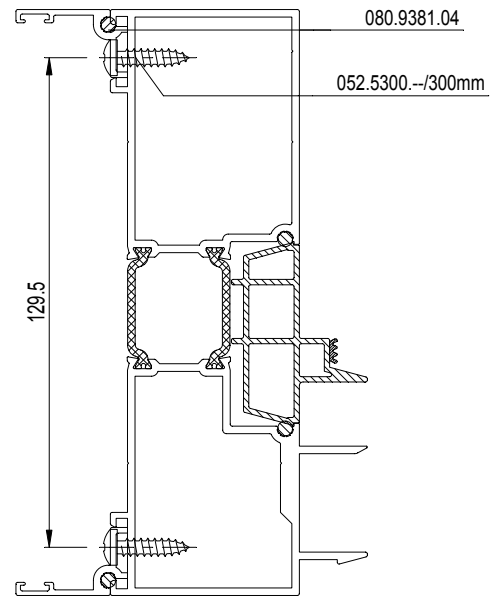
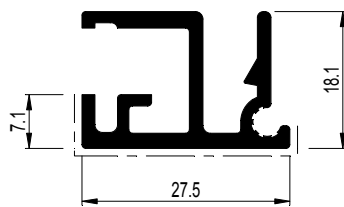

CP 155 CP 155-LS

HULPPROFIELEN
PROFILES DE RACCORDEMENT
ADDITIONAL PROFILES
ZUSATZPROFILE



	A dm ² /m	P dm ² /m	L_m	I_x cm ⁴	W_x cm ³	a_x mm	I_y cm ⁴	W_y cm ³	a_y mm	Y X 0 Y
030.1141.00	-	-	7.00	5.619	1.673	21.01	1.162	0.789	14.73	

030.1141.00

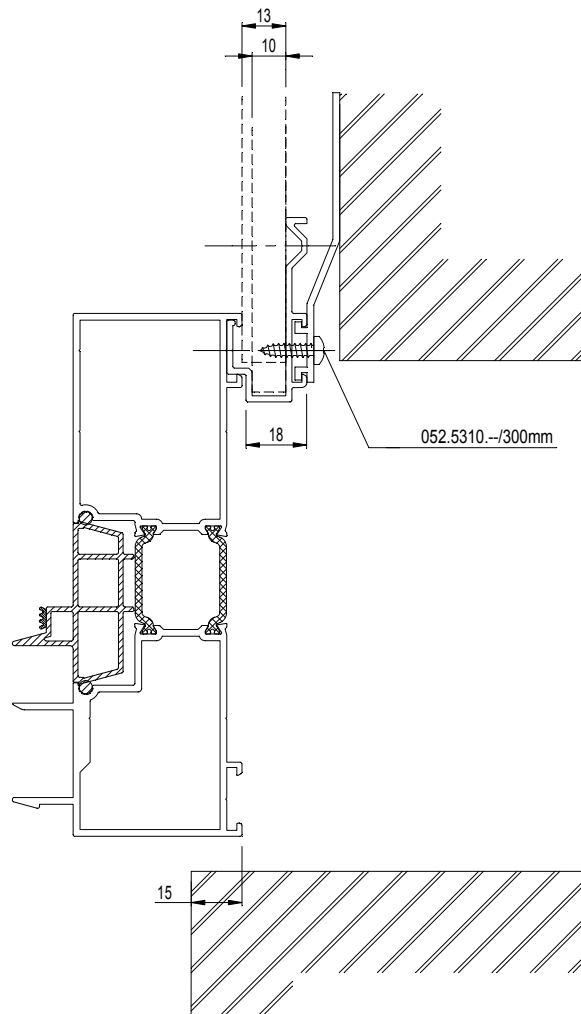
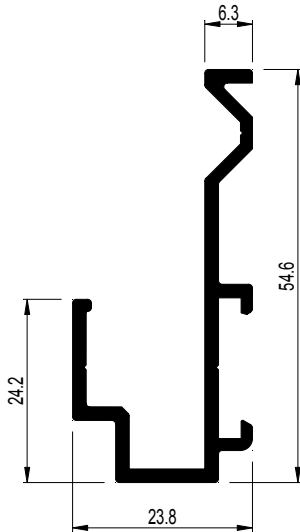

CP 155-LS

AFDEKKAP MOTOR
 CAPUCHON POUR MOTEUR
 COVER MOTOR
 ABDECKKAPPE ANTRIEB



	$\frac{A}{dm^2/m}$	$\frac{P}{dm^2/m}$	L_m	$I_x \text{ cm}^4$	$W_x \text{ cm}^3$	$ax \text{ mm}$	$I_y \text{ cm}^4$	$W_y \text{ cm}^3$	$ay \text{ mm}$	
006.0365.XX	26.92	12.4	7.00	13.144	3.332	28.55	4.099	1.096	37.40	X — X 0 — Y Y — Y

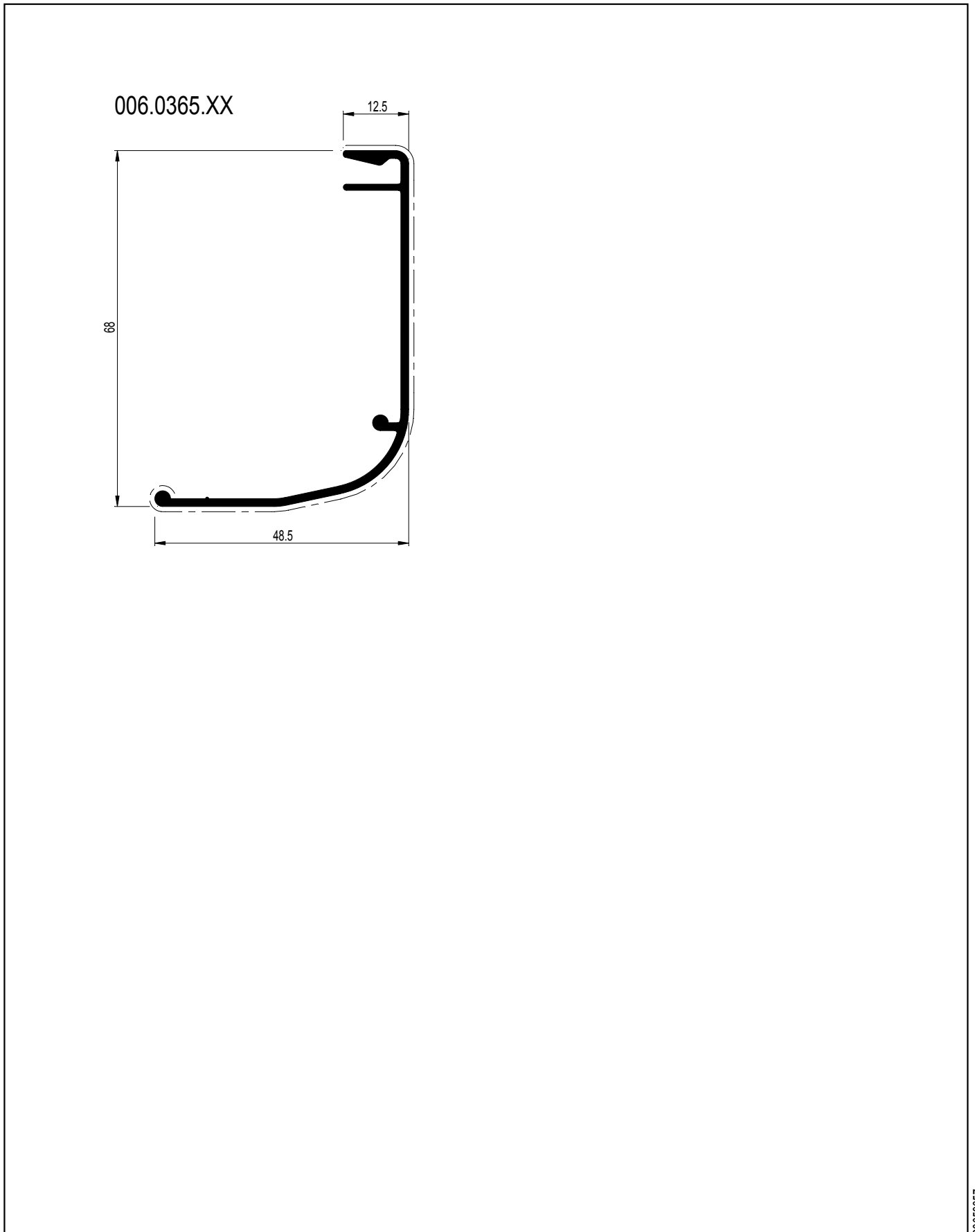

	$\frac{A}{dm^2/m}$	$\frac{P}{dm^2/m}$	$\leftarrow L_m \rightarrow$	$I_x \text{ cm}^4$	$W_x \text{ cm}^3$	ax mm	$I_y \text{ cm}^4$	$W_y \text{ cm}^3$	ay mm	
006.0317.XX	18.81	6.2	7.00	1.532	1.473	10.41	7.627	2.667	26.21	Y — X X — 0
006.0318.XX	26.03	7.9	7.00	1.889	1.713	8.98	20.289	4.479	45.30	
007.0767.01	-	-	7.00	-	-	-	-	-	-	

006.0317.XX

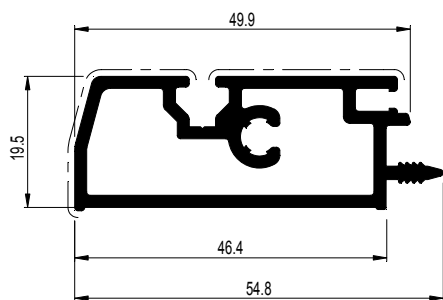

007.0767.01

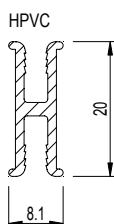

006.0318.XX

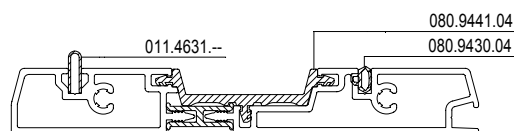
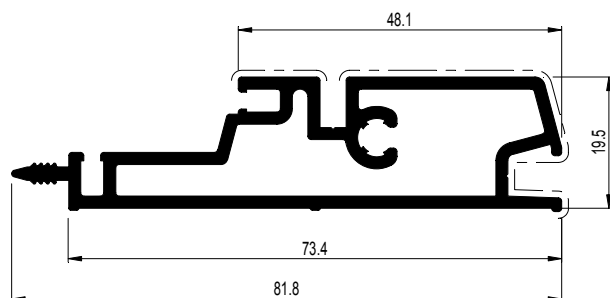

D

Doorsnedetekeningen

Sections des noeuds

Section drawings

Profilkombinationen

CP 155

2-RAIL
2-RAIL
2-RAIL
2-RAIL



OPTIE A
OPTION A
OPTION A
OPTION A

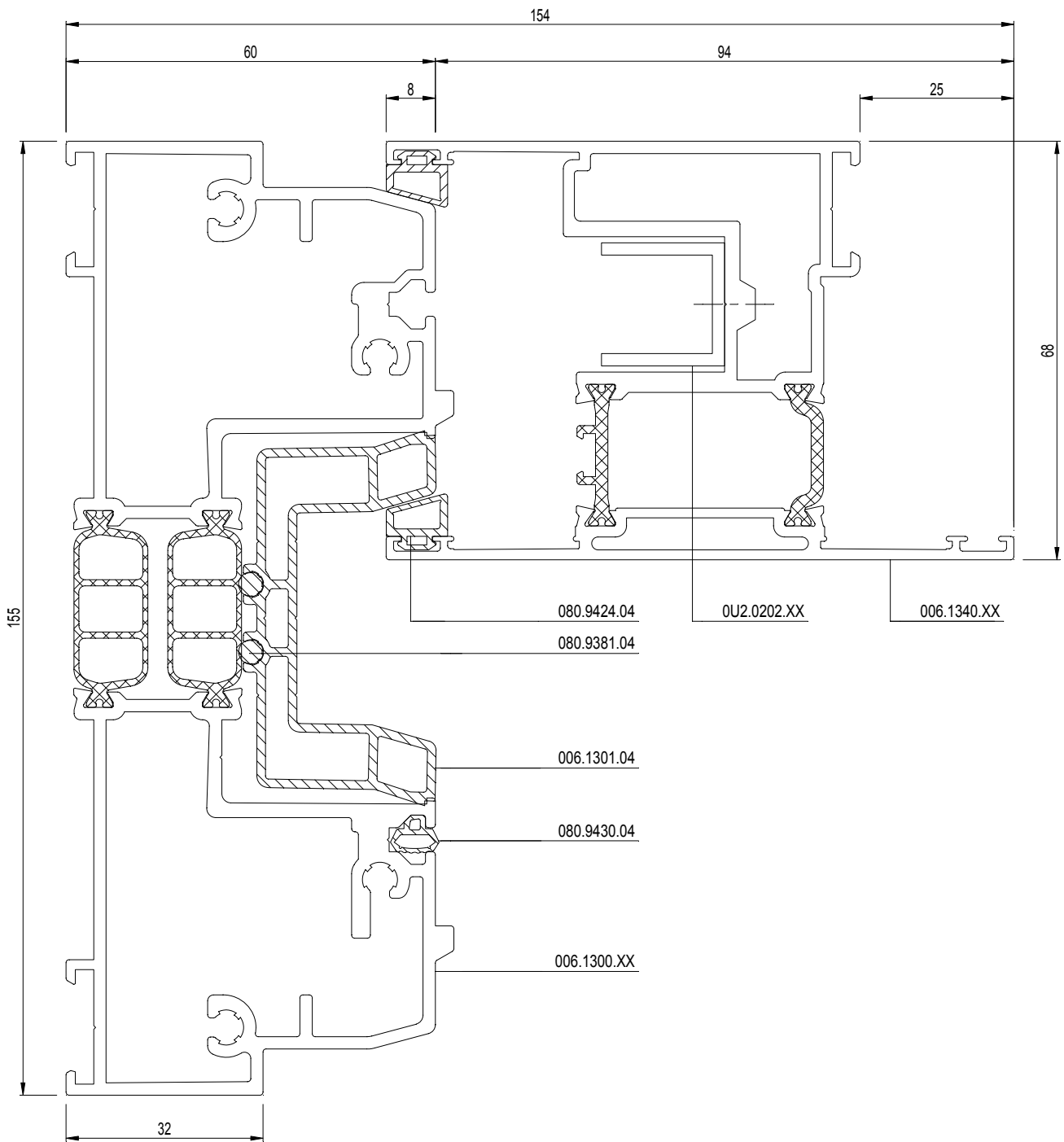
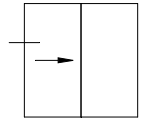

VARIANT - OPTIE B
VARIANTE - OPTION B
VARIANT - OPTION B
VARIANTE - OPTION B

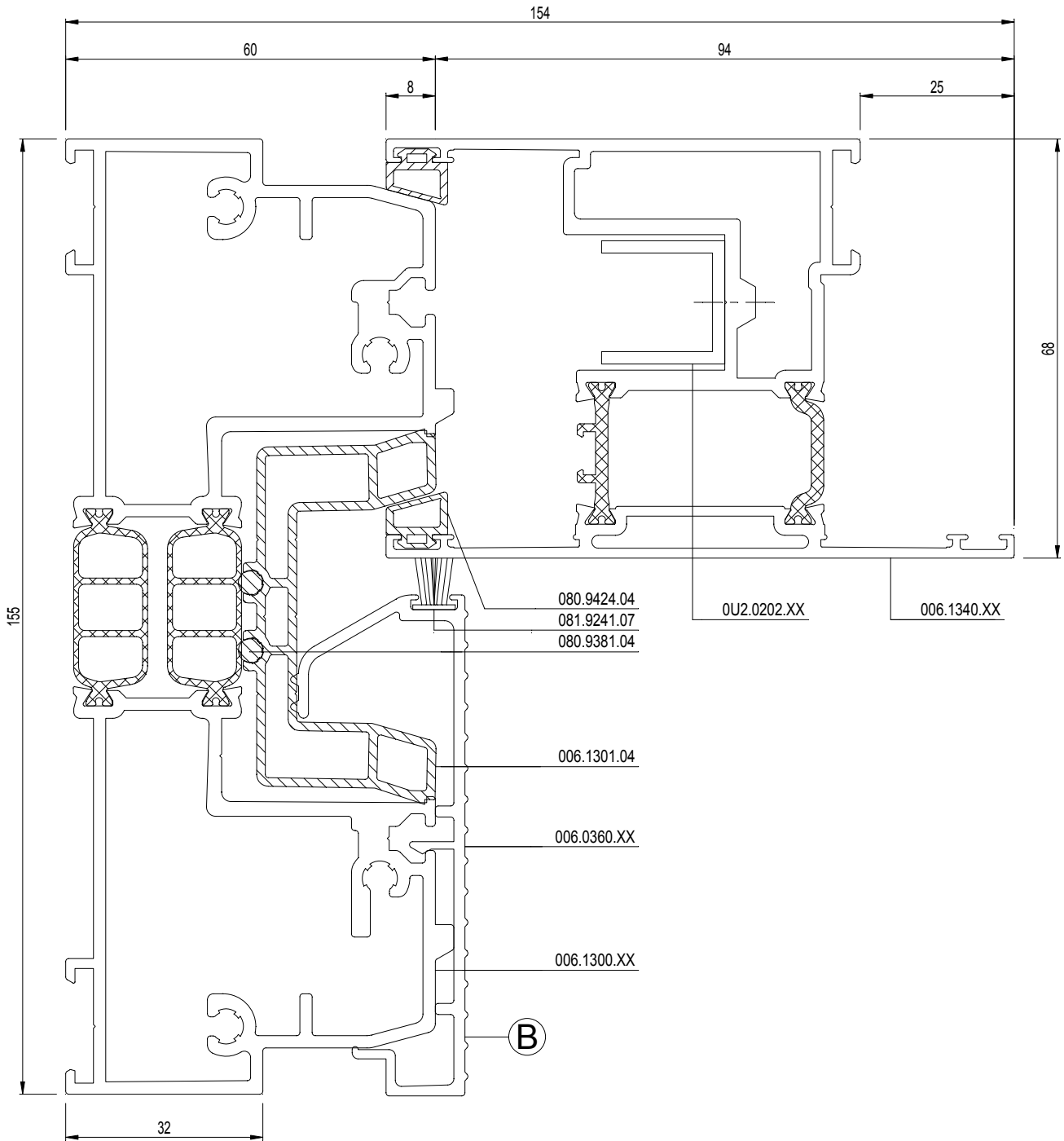
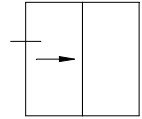

VARIANT - OPTIE D = HI
VARIANTE - OPTION D = HI
VARIANT - OPTION D = HI
VARIANTE - OPTION D = HI

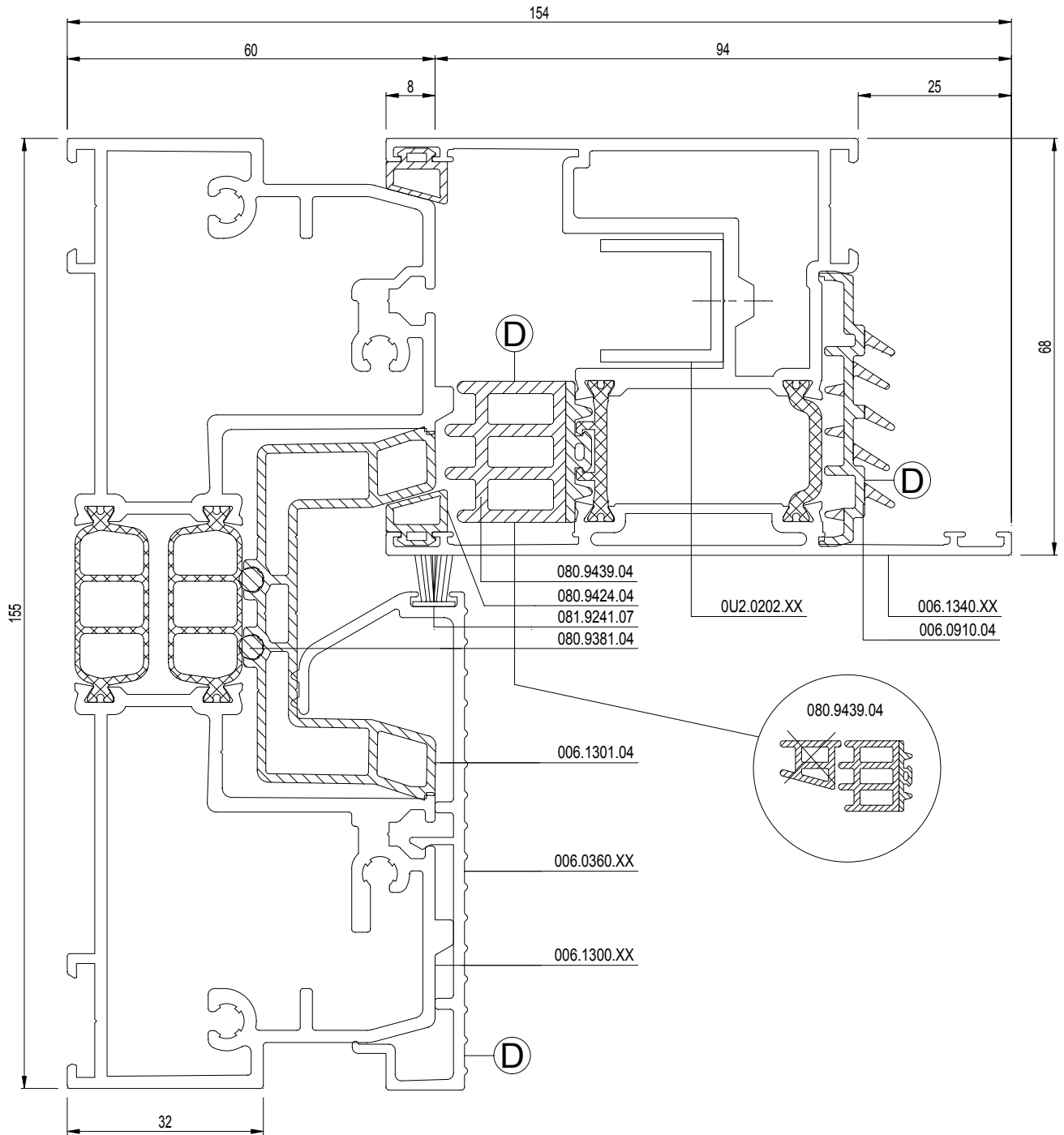
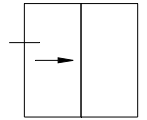

CP 155

2-RAIL
2-RAIL
2-RAIL
2-RAIL



OPTIE C = HI
OPTION C = HI
OPTION C = HI
OPTION C = HI

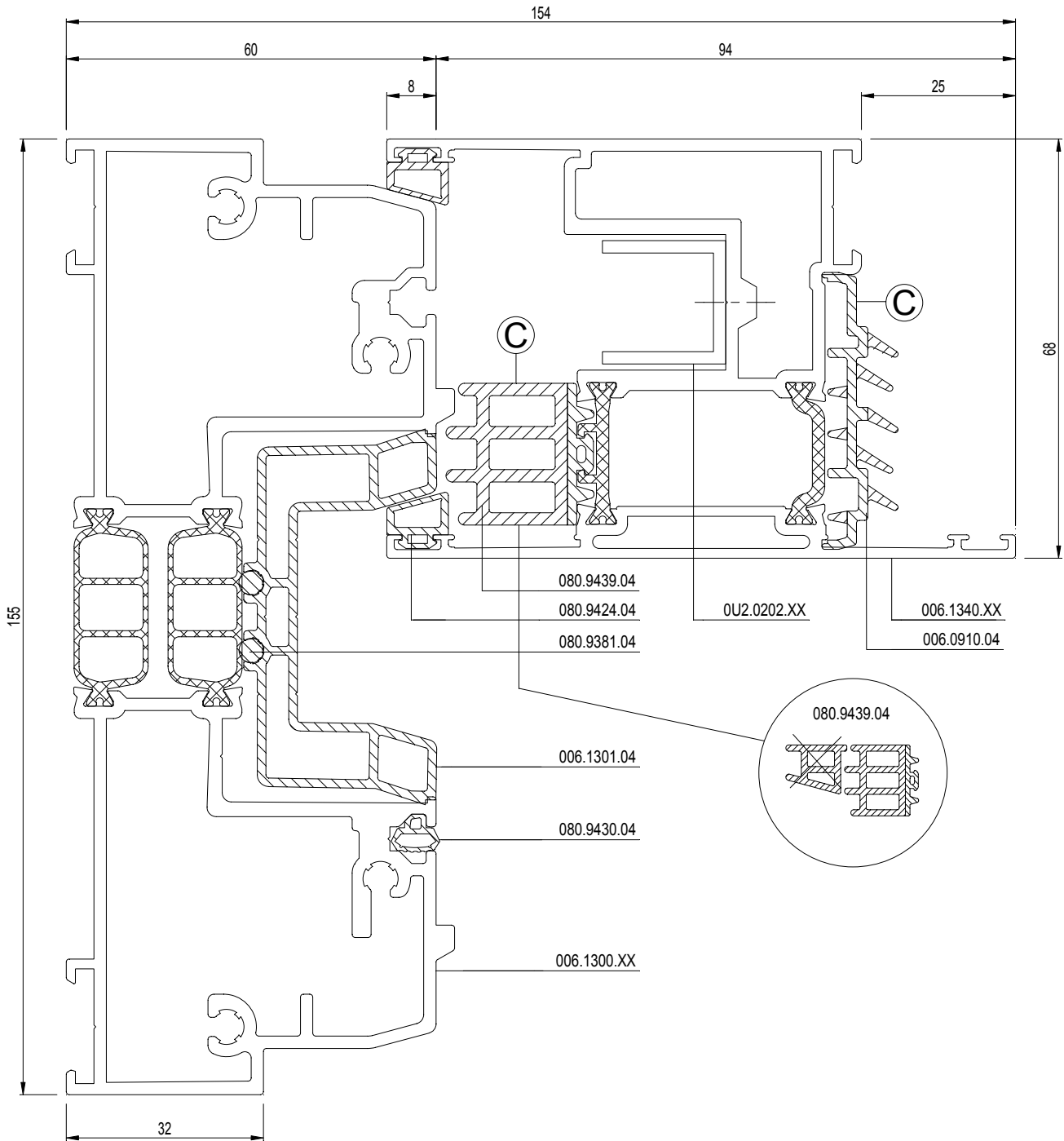
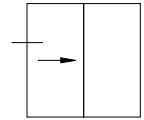

OPTIE A
OPTION A
OPTION A
OPTION A

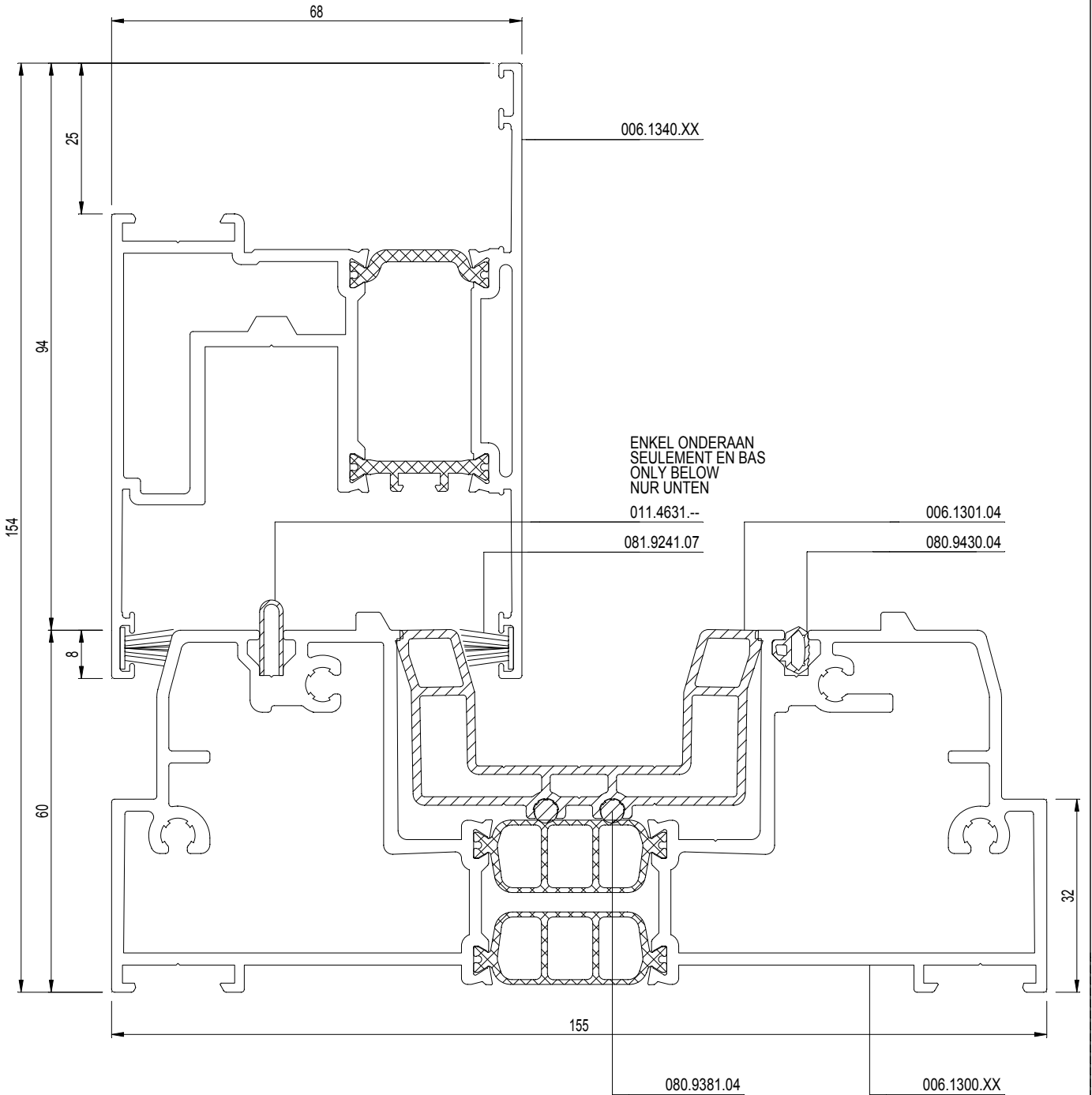
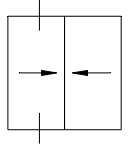

VARIANT - OPTIE B
VARIANTE - OPTION B
VARIANT - OPTION B
VARIANTE - OPTION B

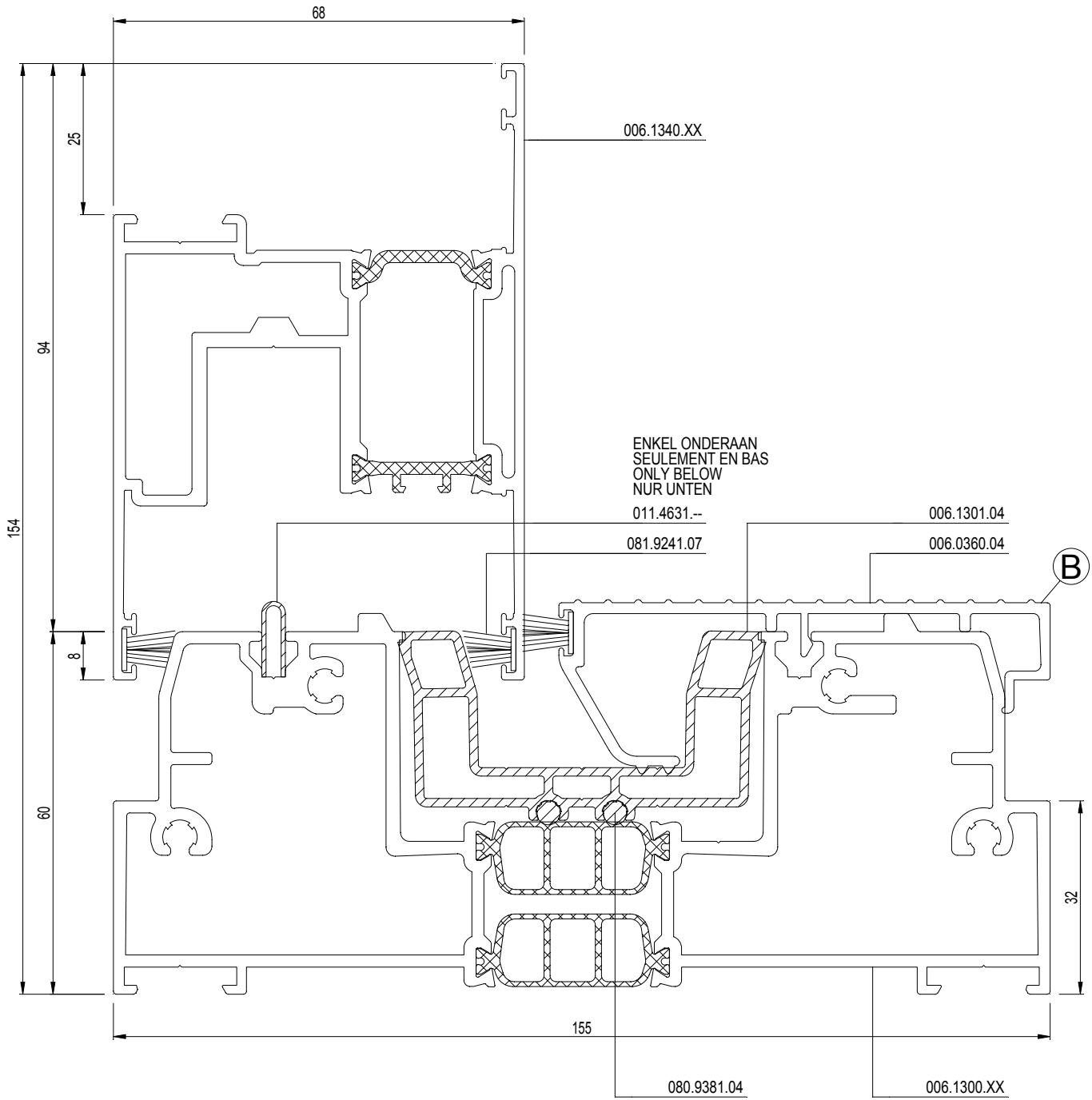
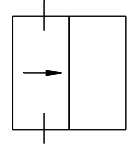

CP 155

2-RAIL
2-RAIL
2-RAIL
2-RAIL



OPTIE C
OPTION C
OPTION C
OPTION C

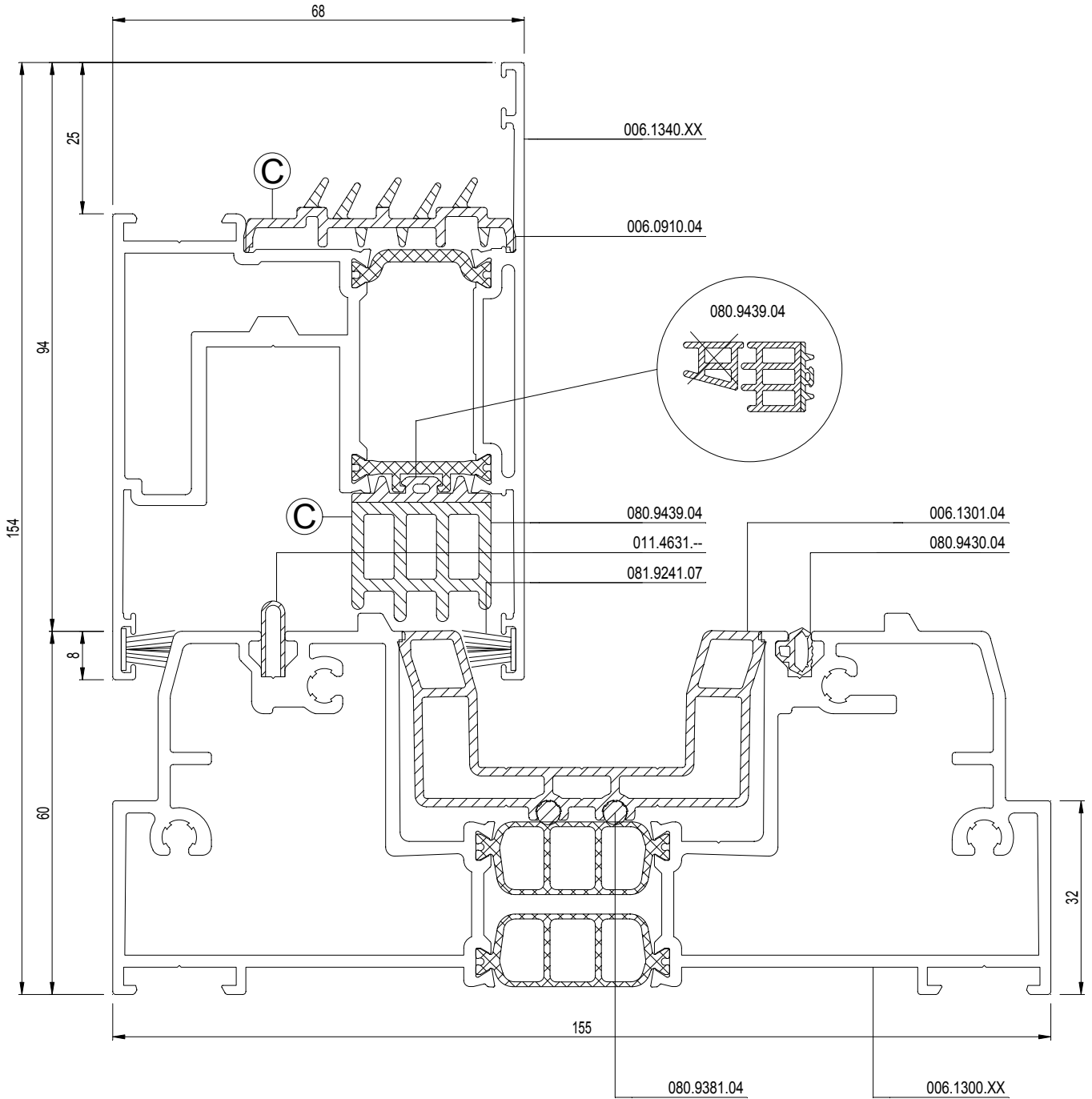
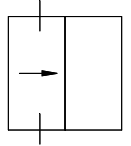

VARIANT - OPTIE D
VARIANTE - OPTION D
VARIANT - OPTION D
VARIANTE - OPTION D

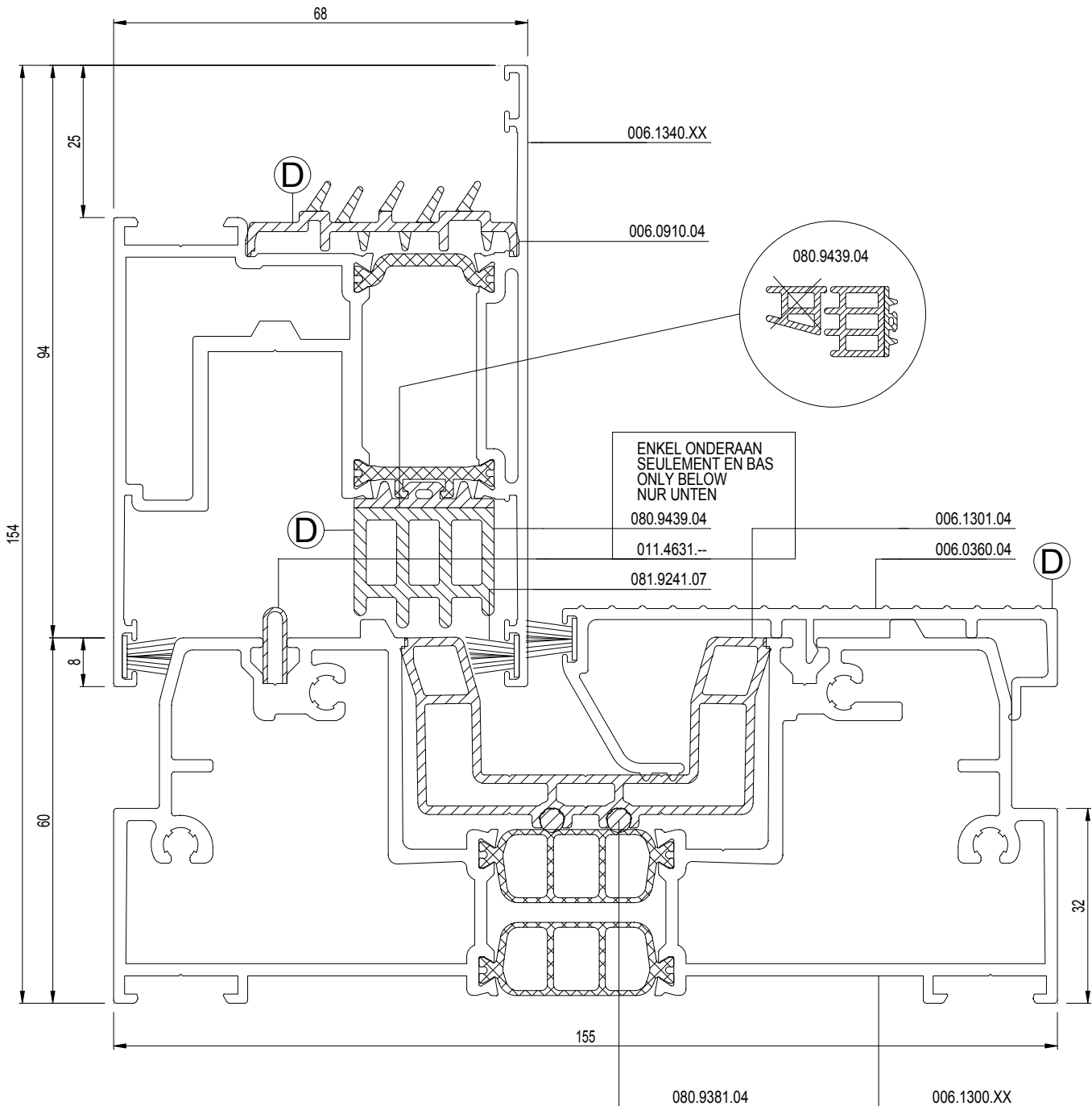

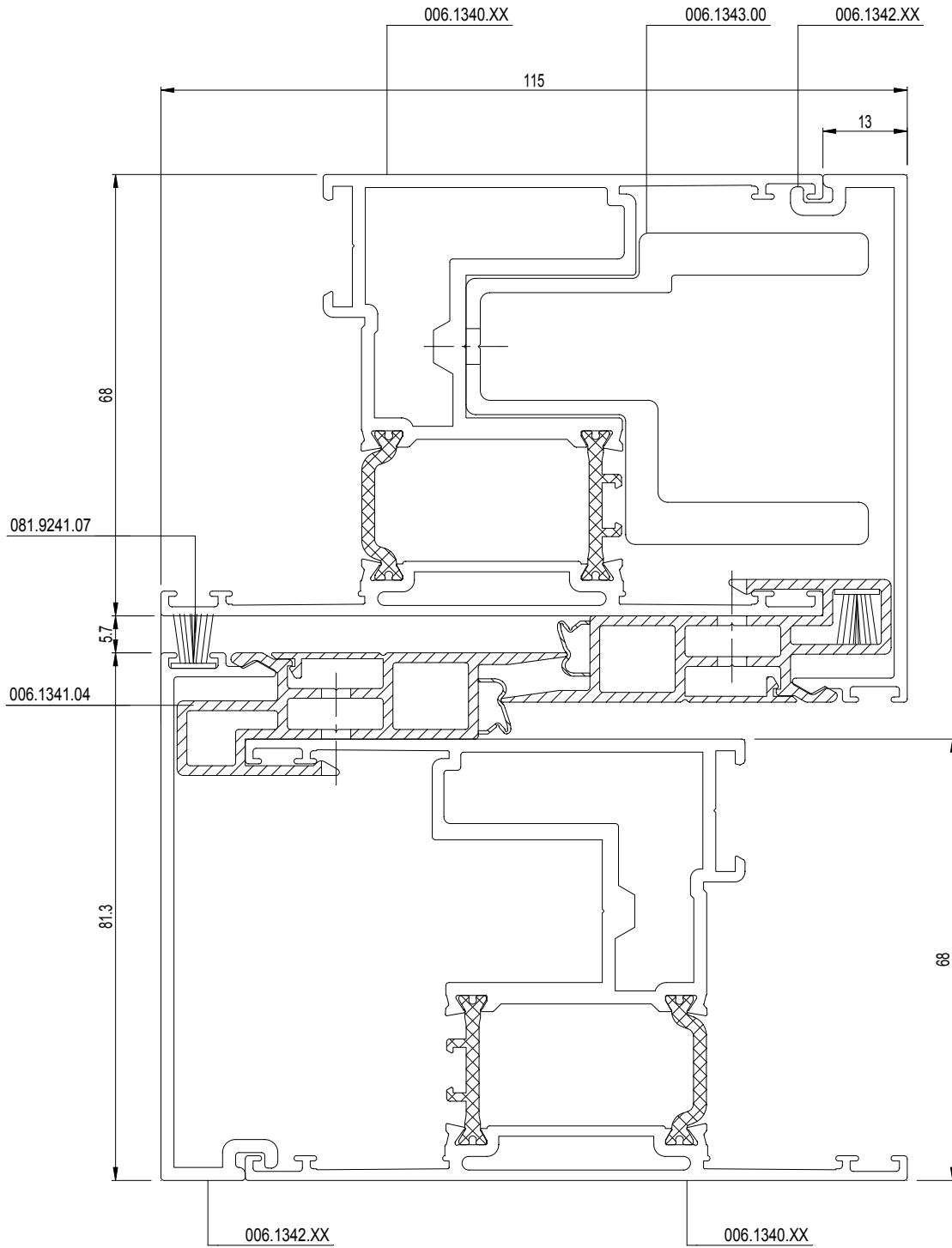
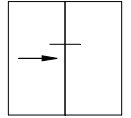

CP 155

2-RAIL
2-RAIL
2-RAIL
2-RAIL

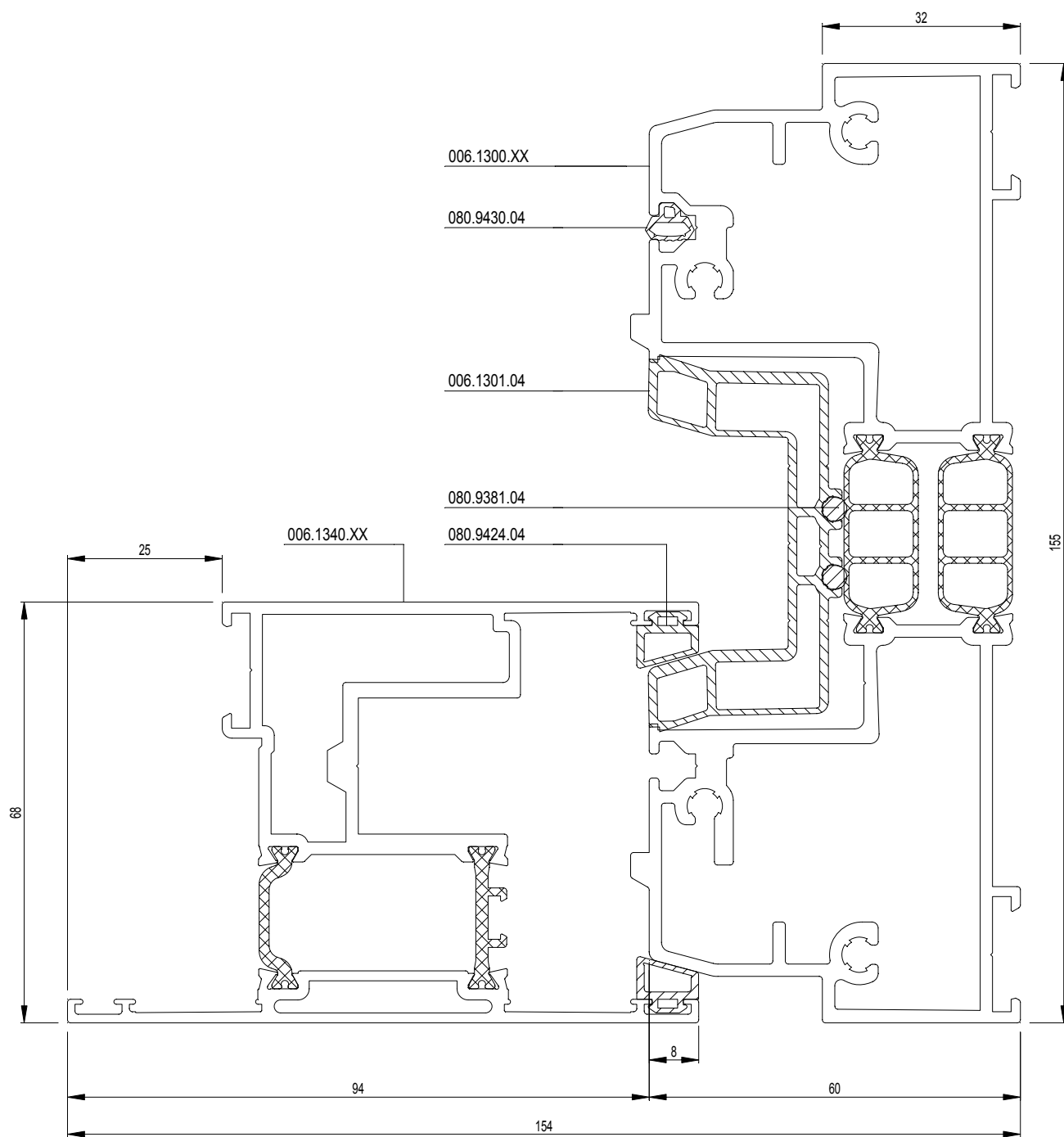
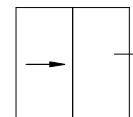

CP 155

2-RAIL
2-RAIL
2-RAIL
2-RAIL

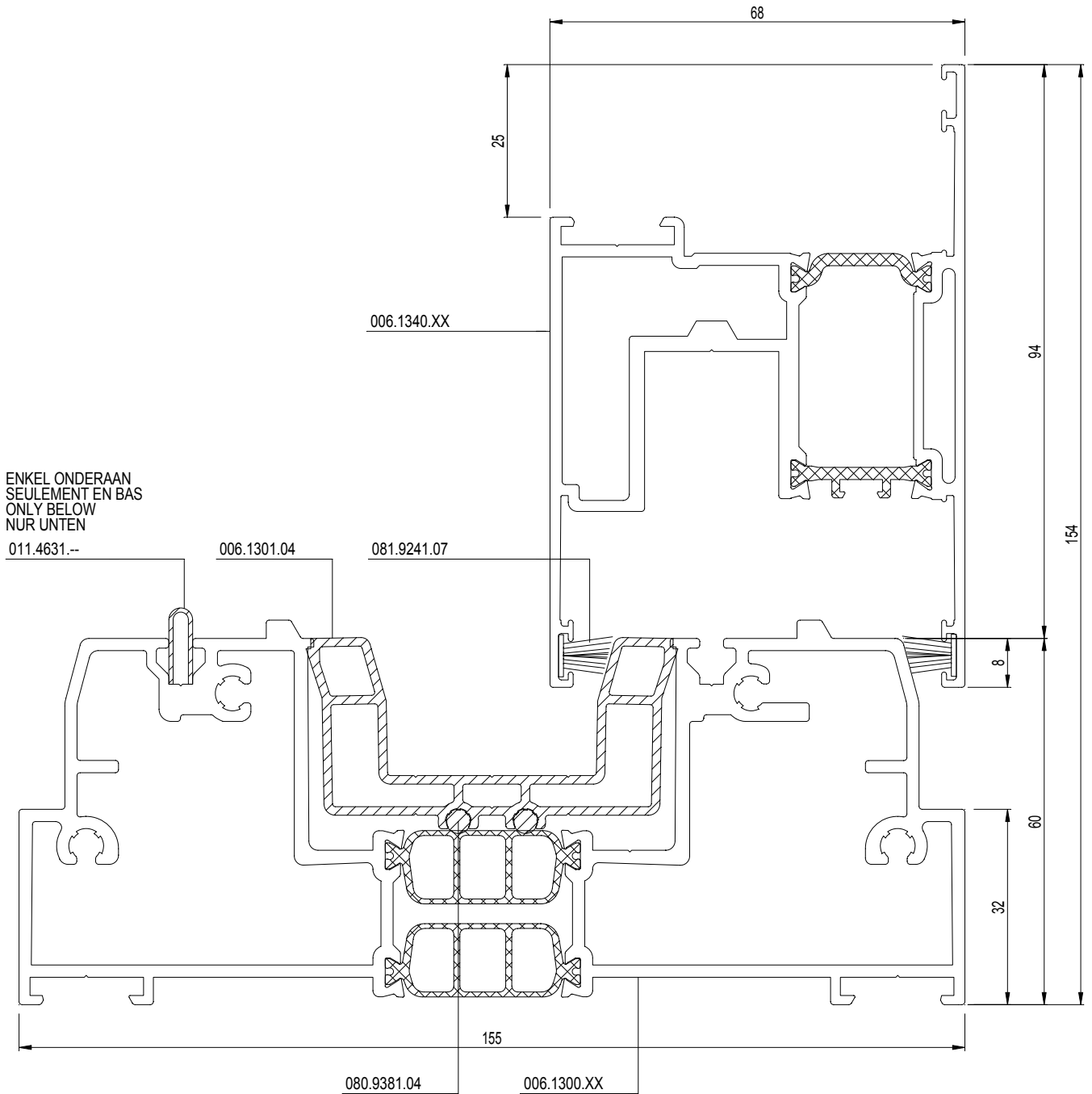
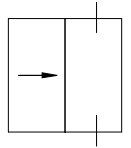

CP 155

2-RAIL
2-RAIL
2-RAIL
2-RAIL

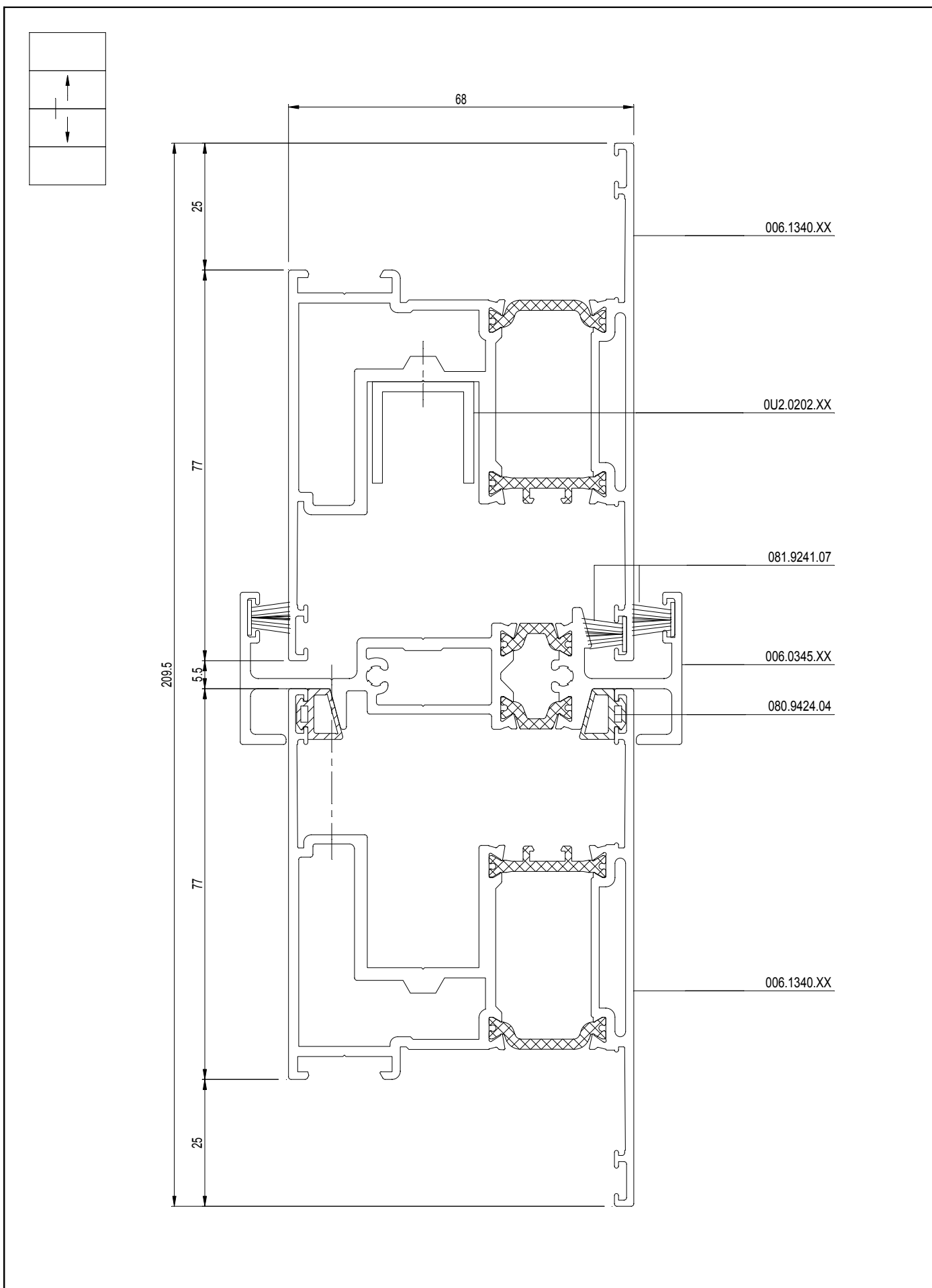

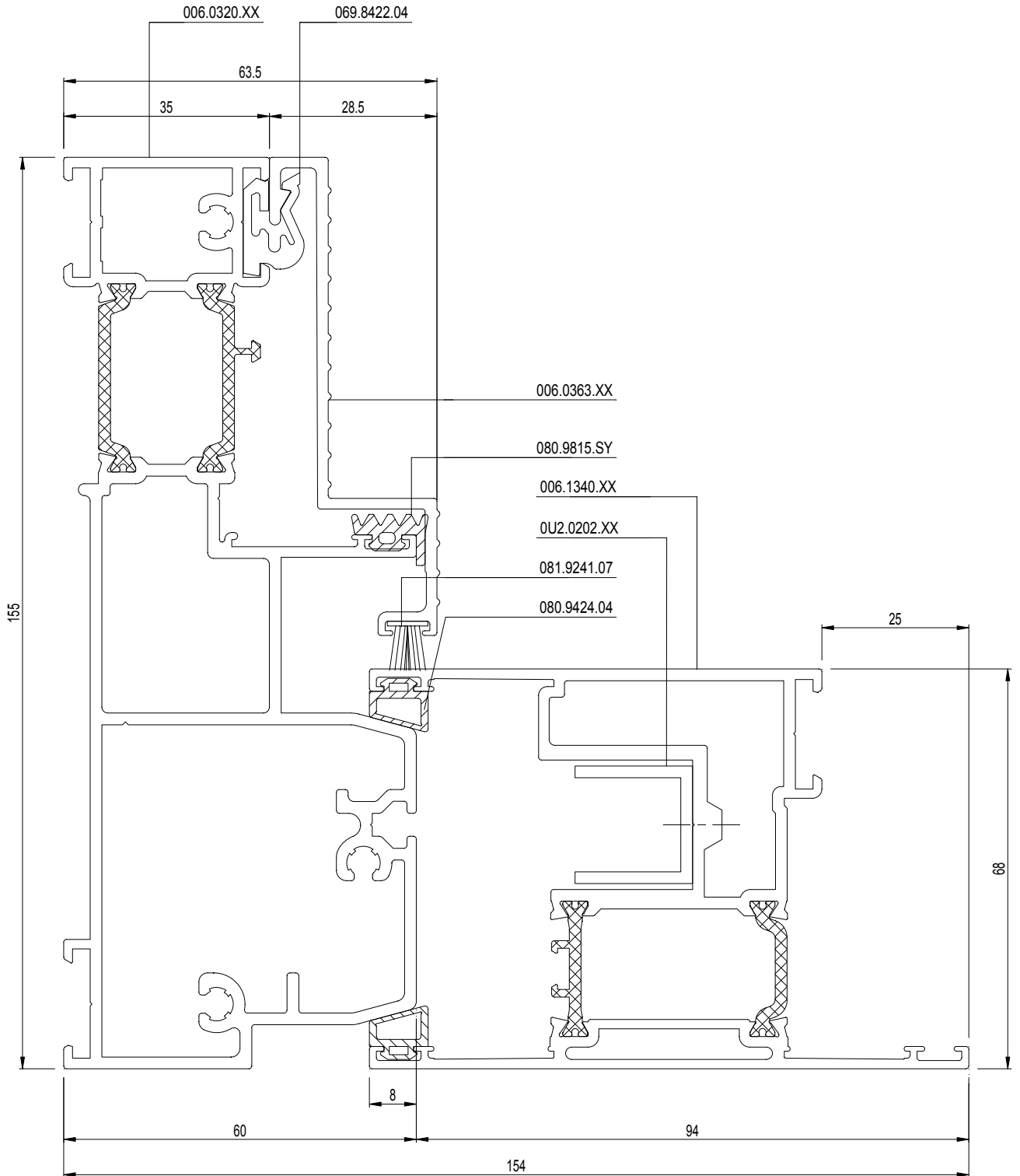
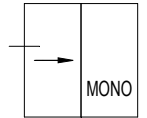

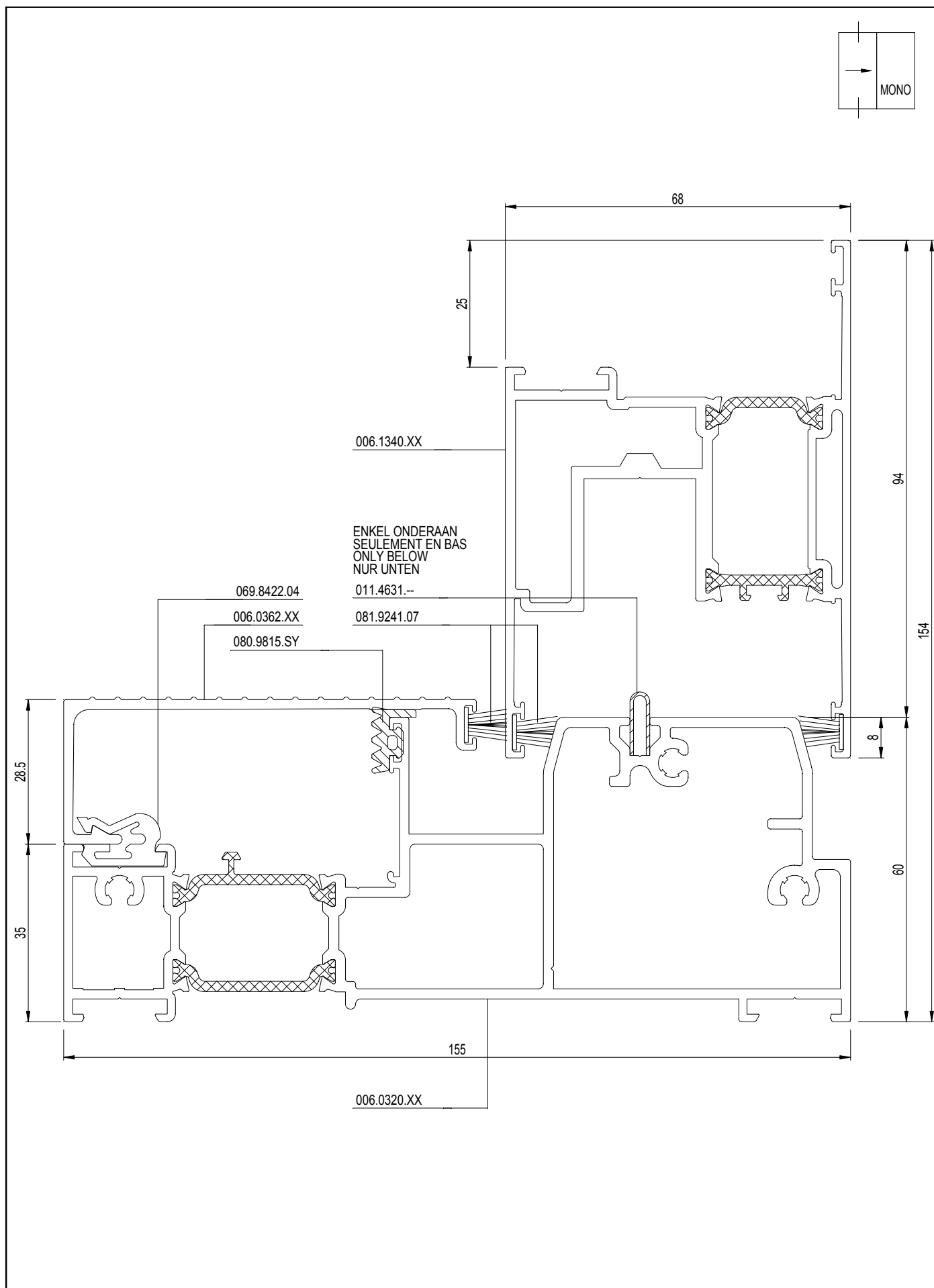

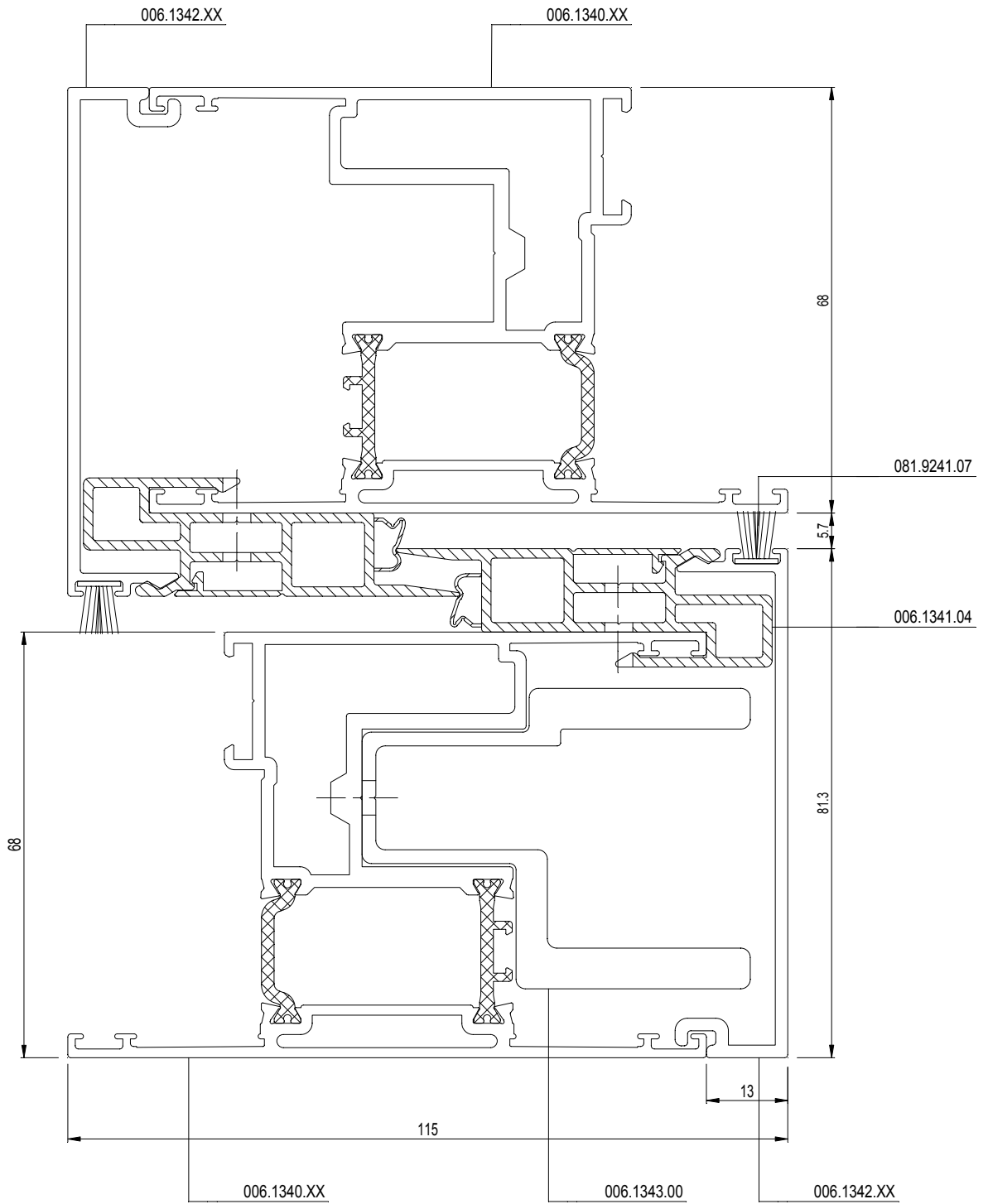
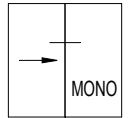

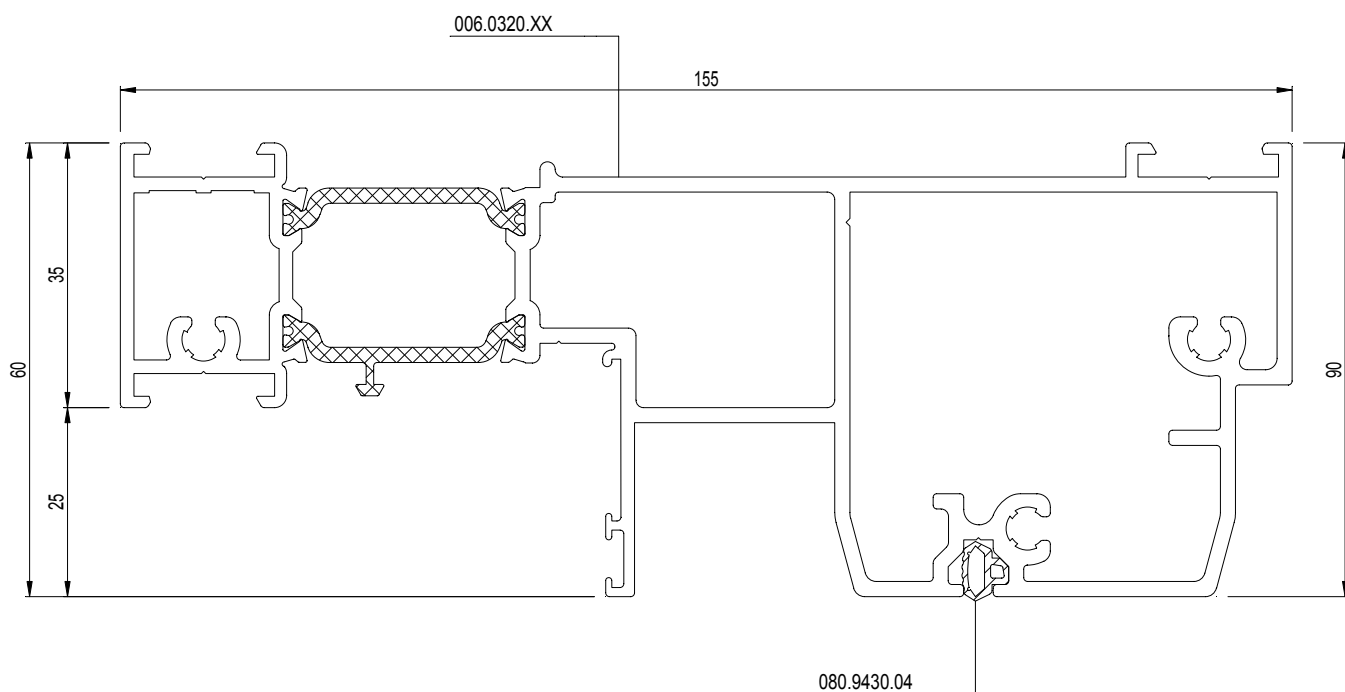
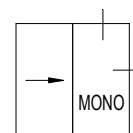

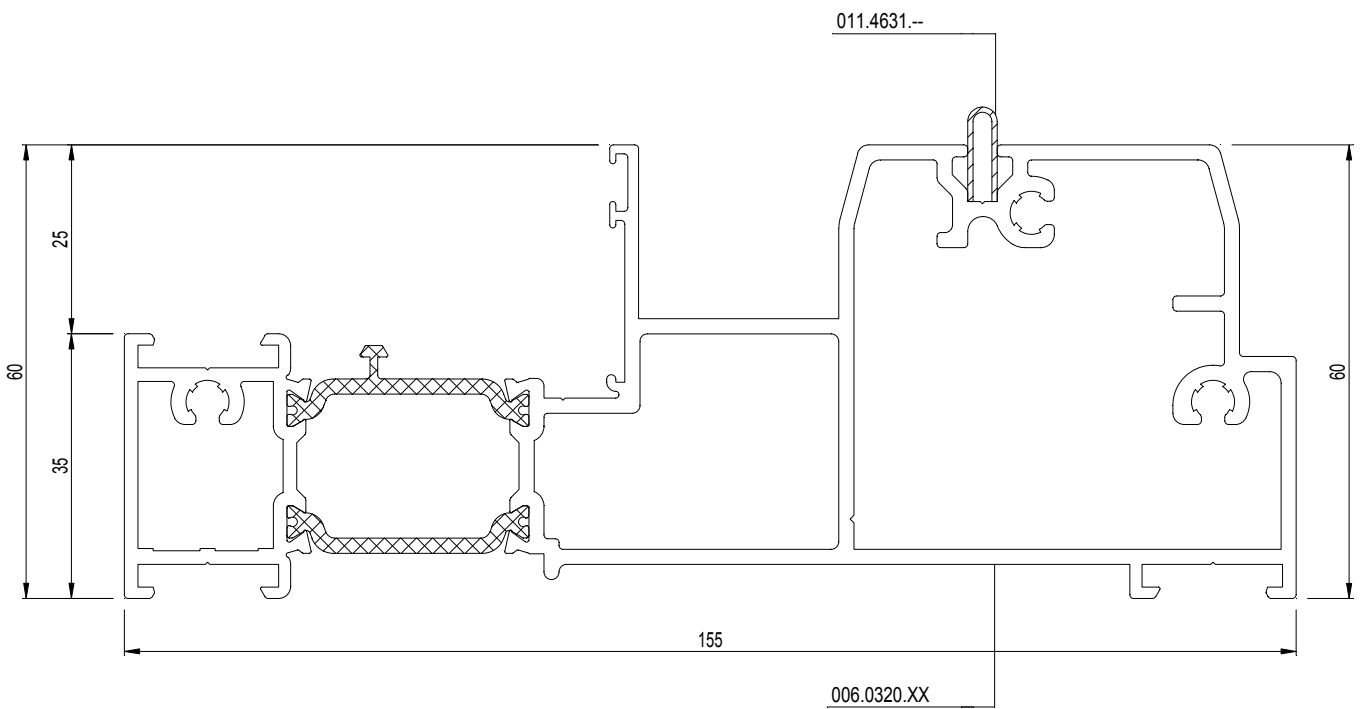
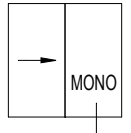

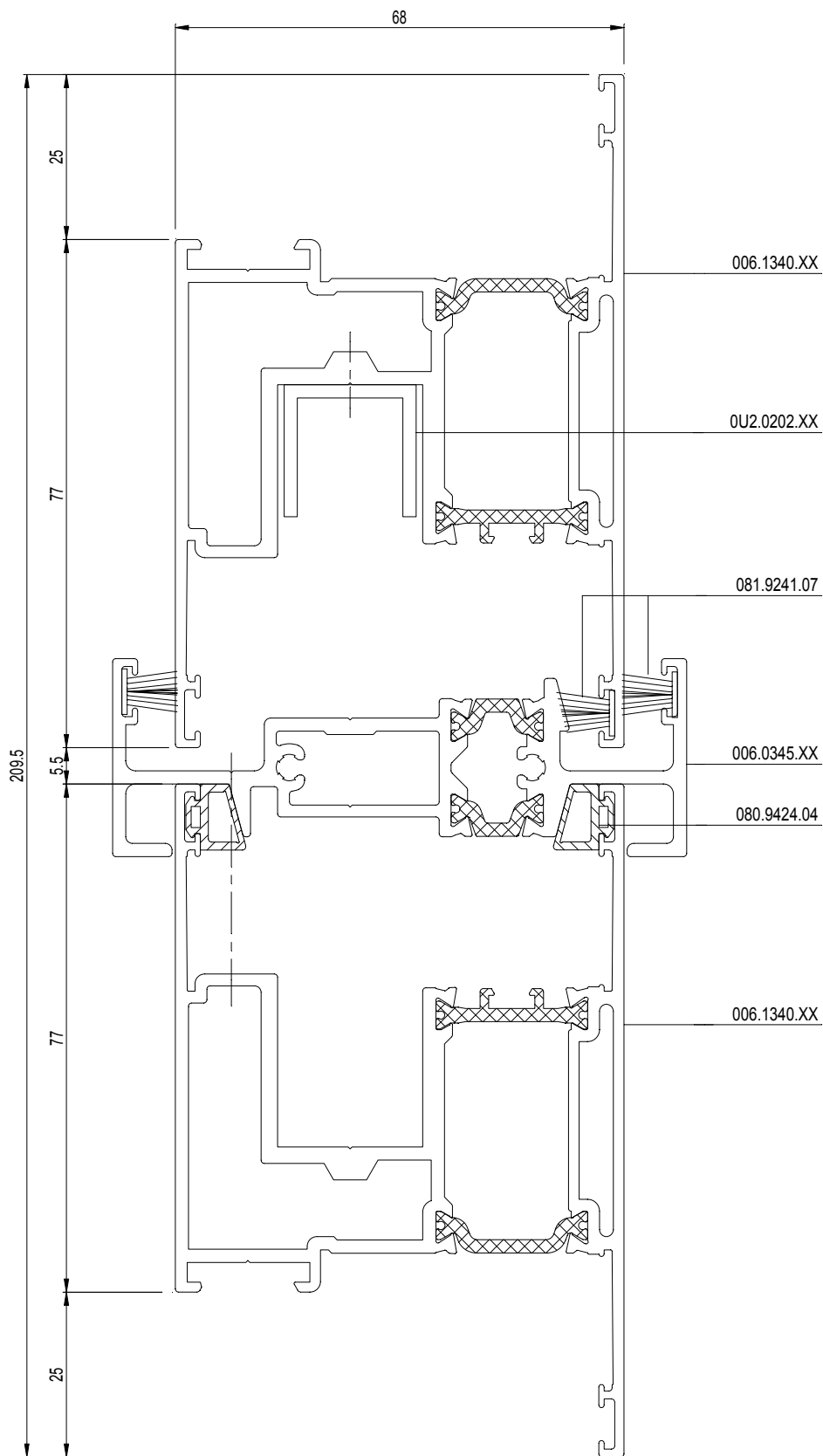
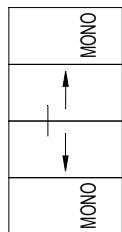

CP 155

3-RAIL
3-RAIL
3-RAIL
3-RAIL

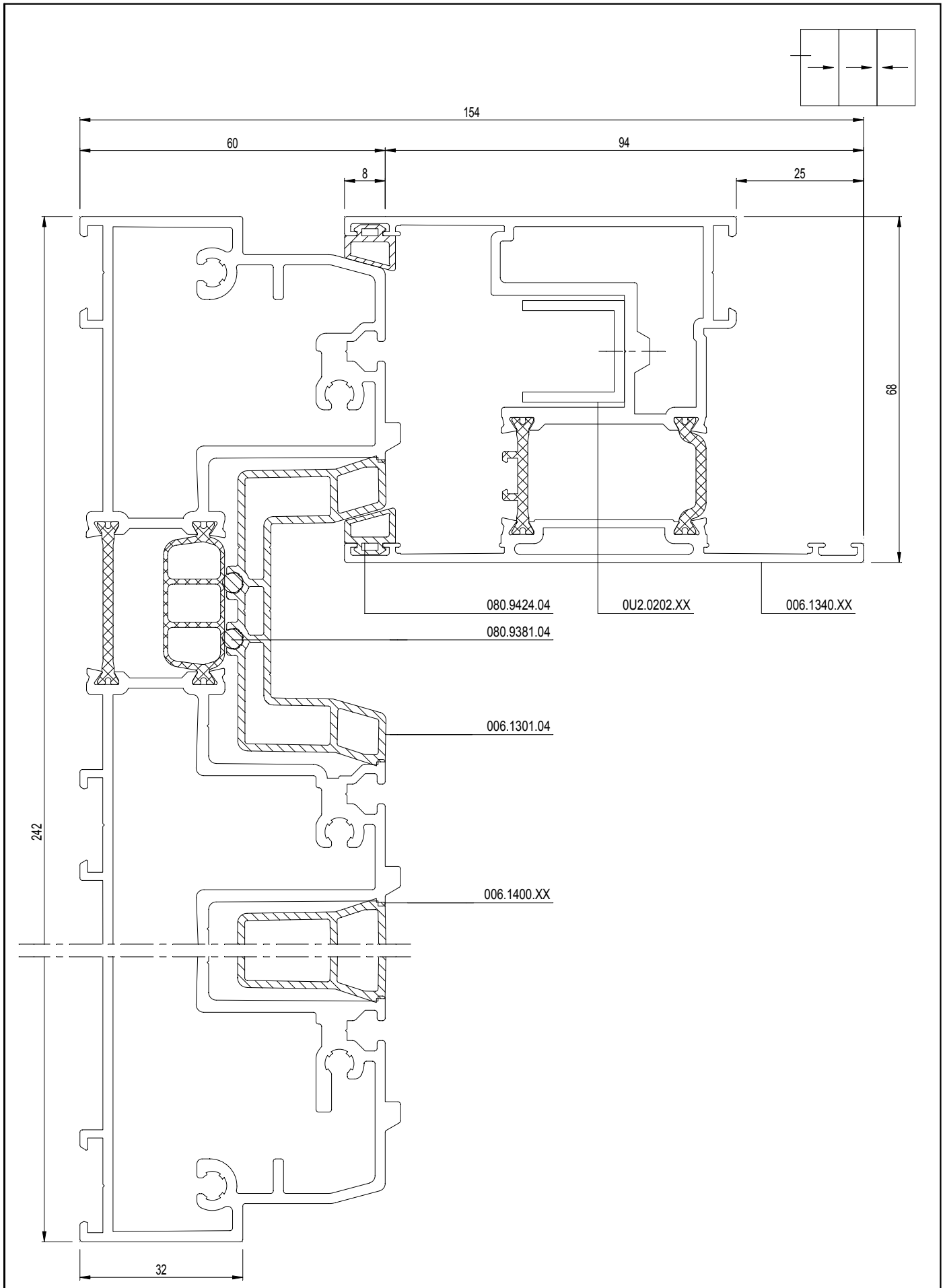

Doorsnedetekeningen
Sections des noeuds
Section drawings
Profilkombinationen

34.D.019
02/2009

D0046238

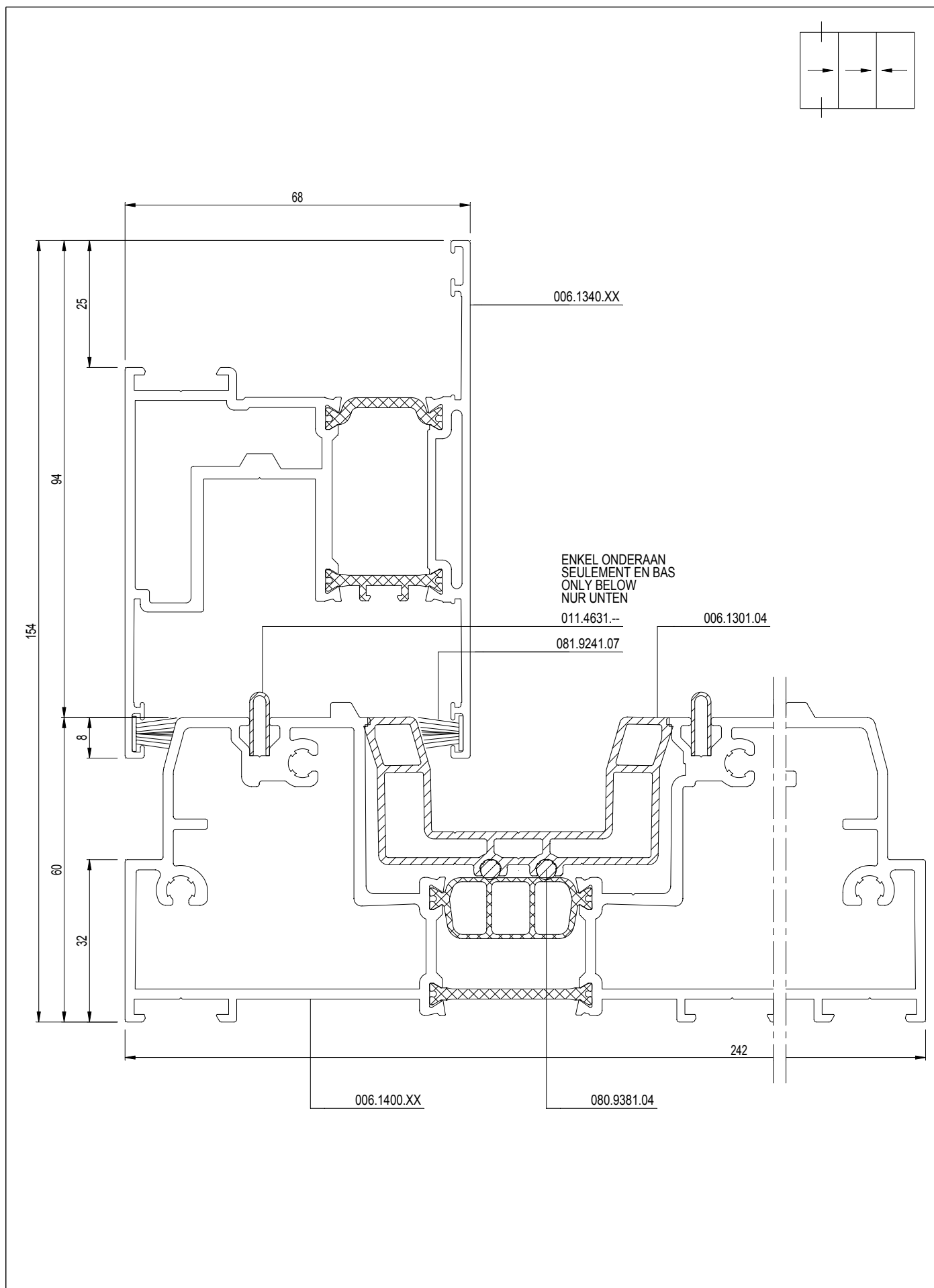

CP 155

3-RAIL
3-RAIL
3-RAIL
3-RAIL

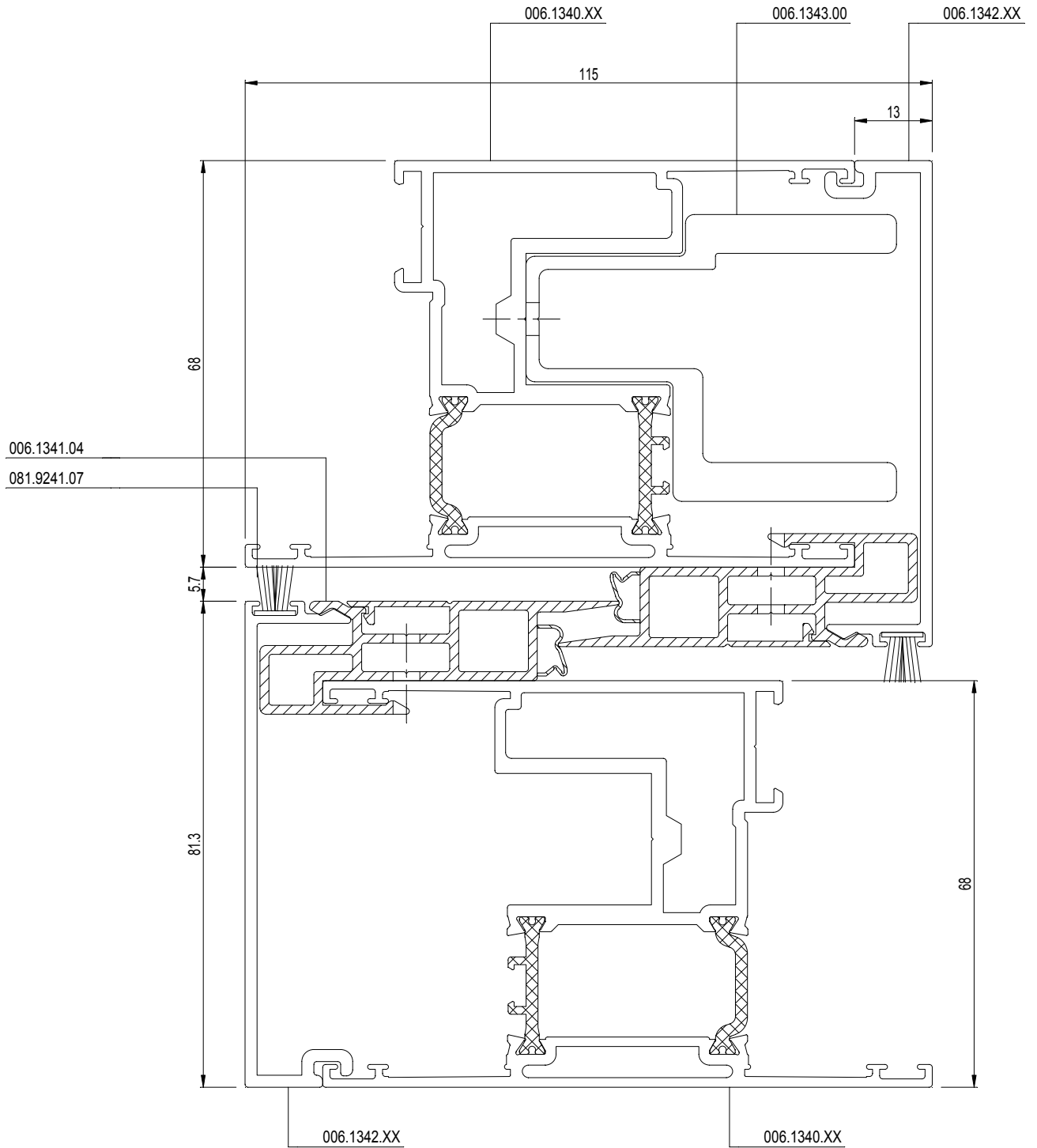
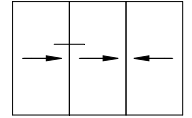

CP 155

3-RAIL
3-RAIL
3-RAIL
3-RAIL

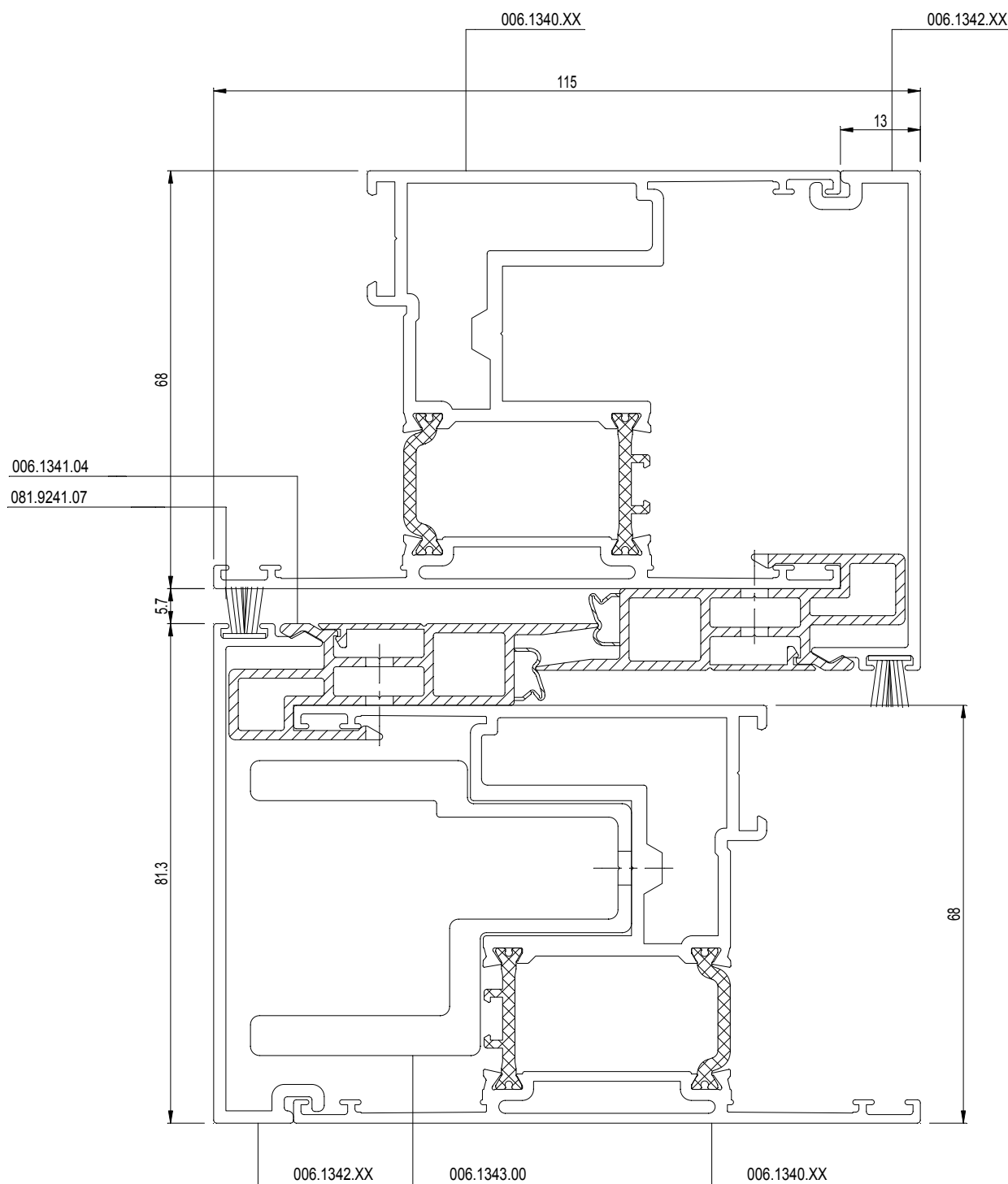
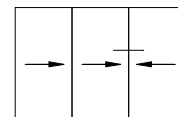

CP 155

3-RAIL
3-RAIL
3-RAIL
3-RAIL

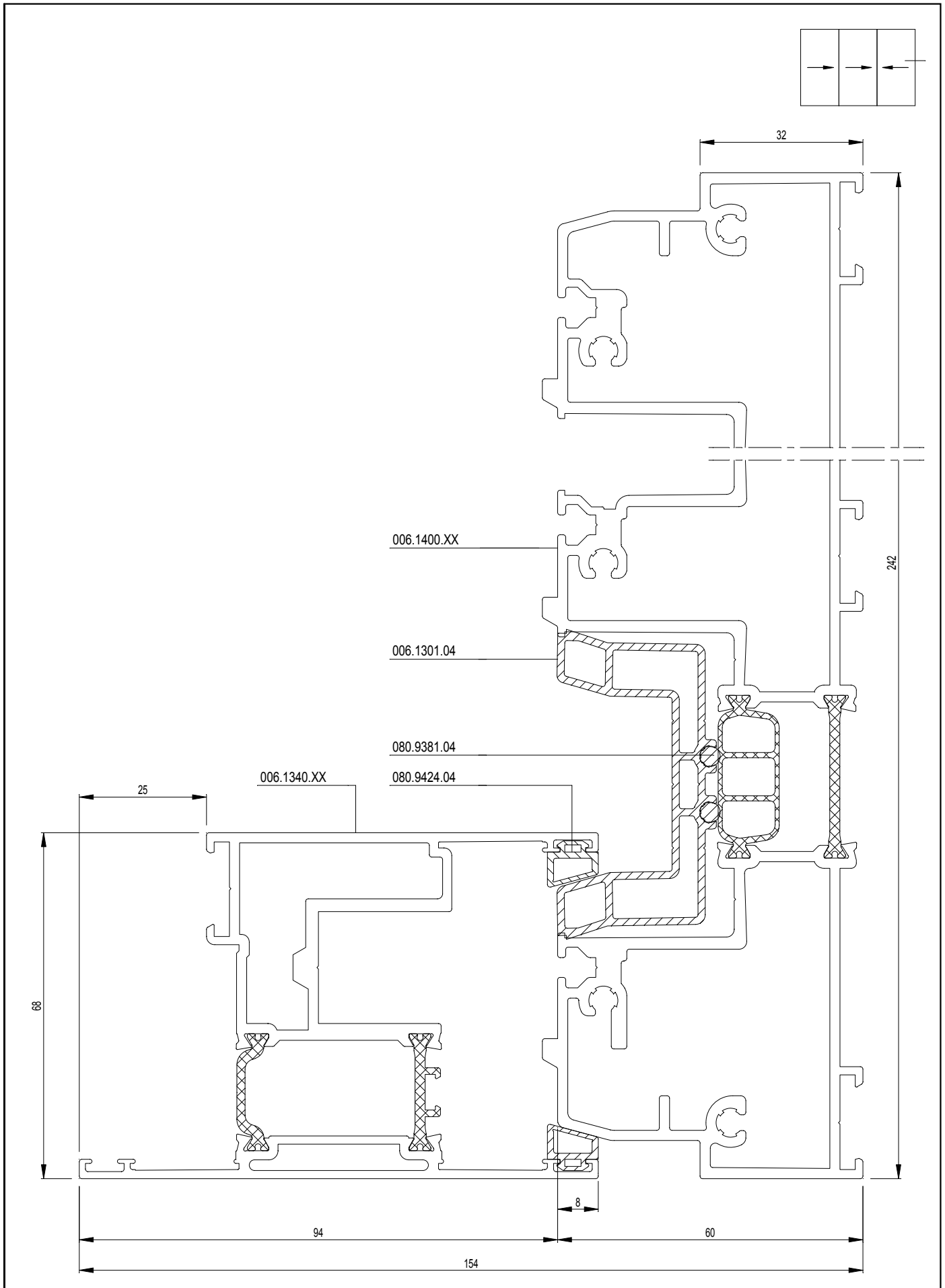

Doorsnedetekeningen
Sections des noeuds
Section drawings
Profilkombinationen

34.D.023
02/2009

D0046242

CP 155-LS

2-RAIL
2-RAIL
2-RAIL
2-RAIL



OPTIE A
OPTION A
OPTION A
OPTION A

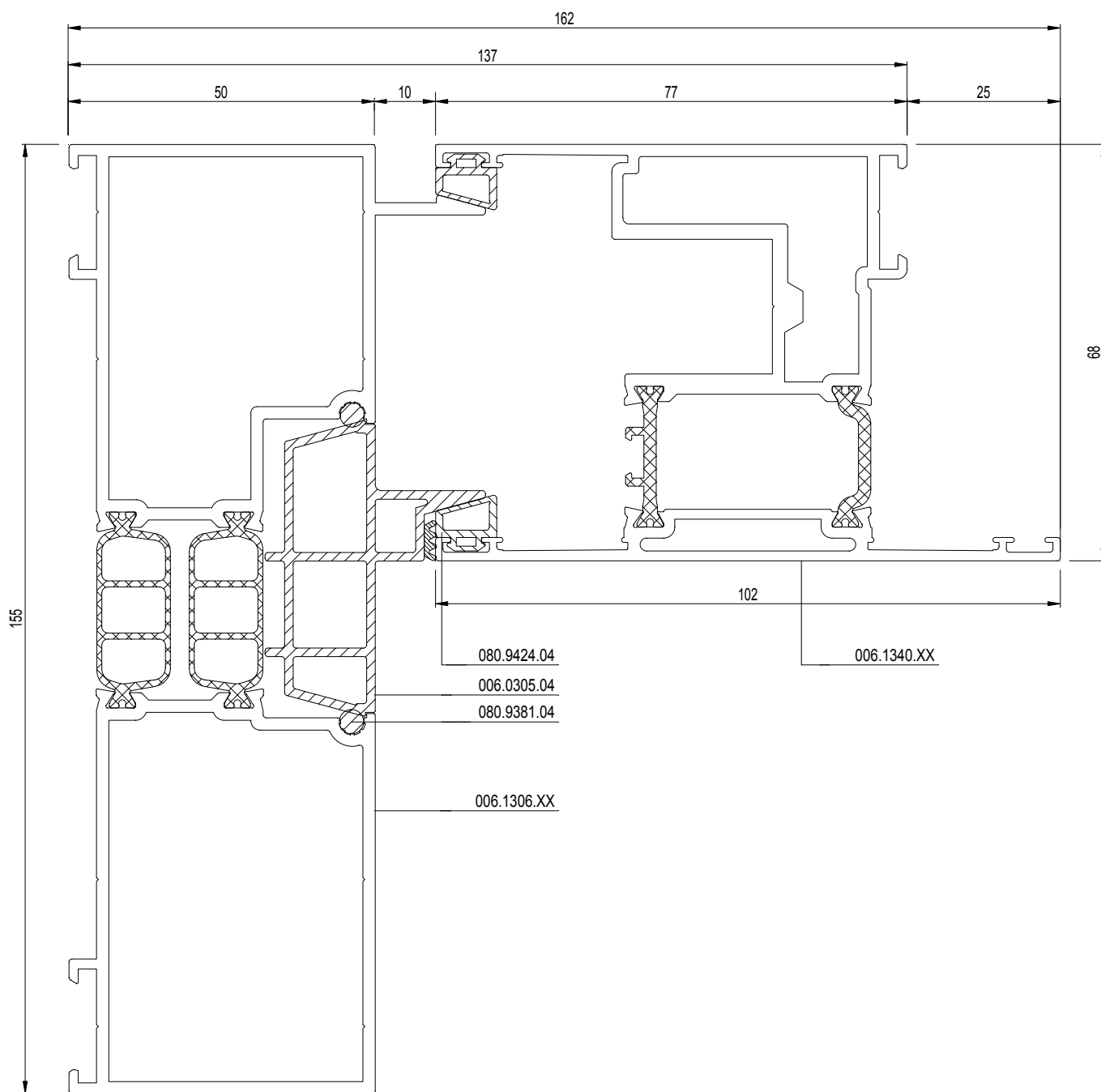
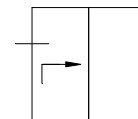

CP 155-LS

2-RAIL
2-RAIL
2-RAIL
2-RAIL



OPTIE B = HI
OPTION B = HI
OPTION B = HI
OPTION B = HI

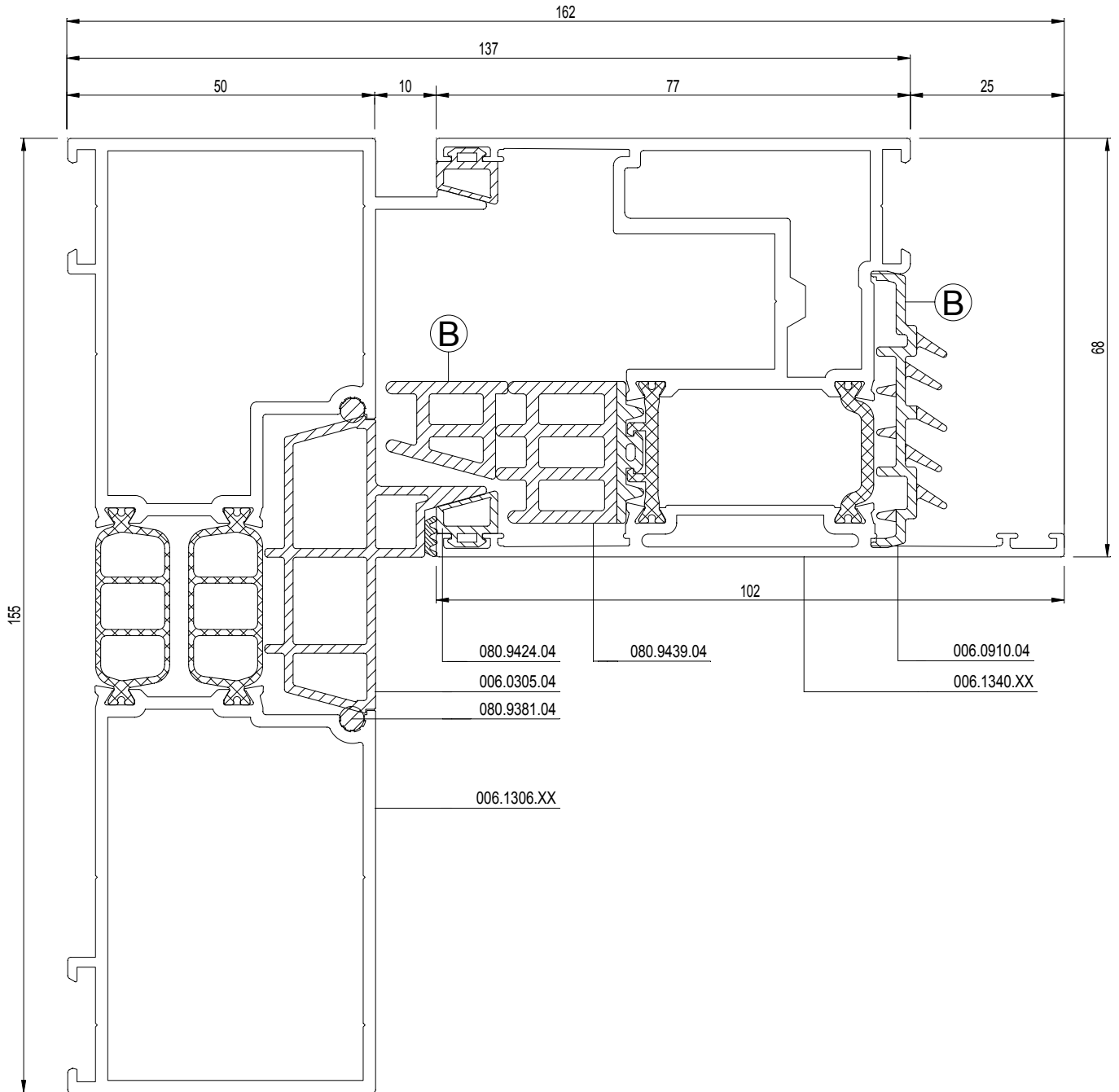
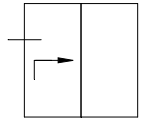

CP 155-LS

2-RAIL
2-RAIL
2-RAIL
2-RAIL



OPTIE A
OPTION A
OPTION A
OPTION A

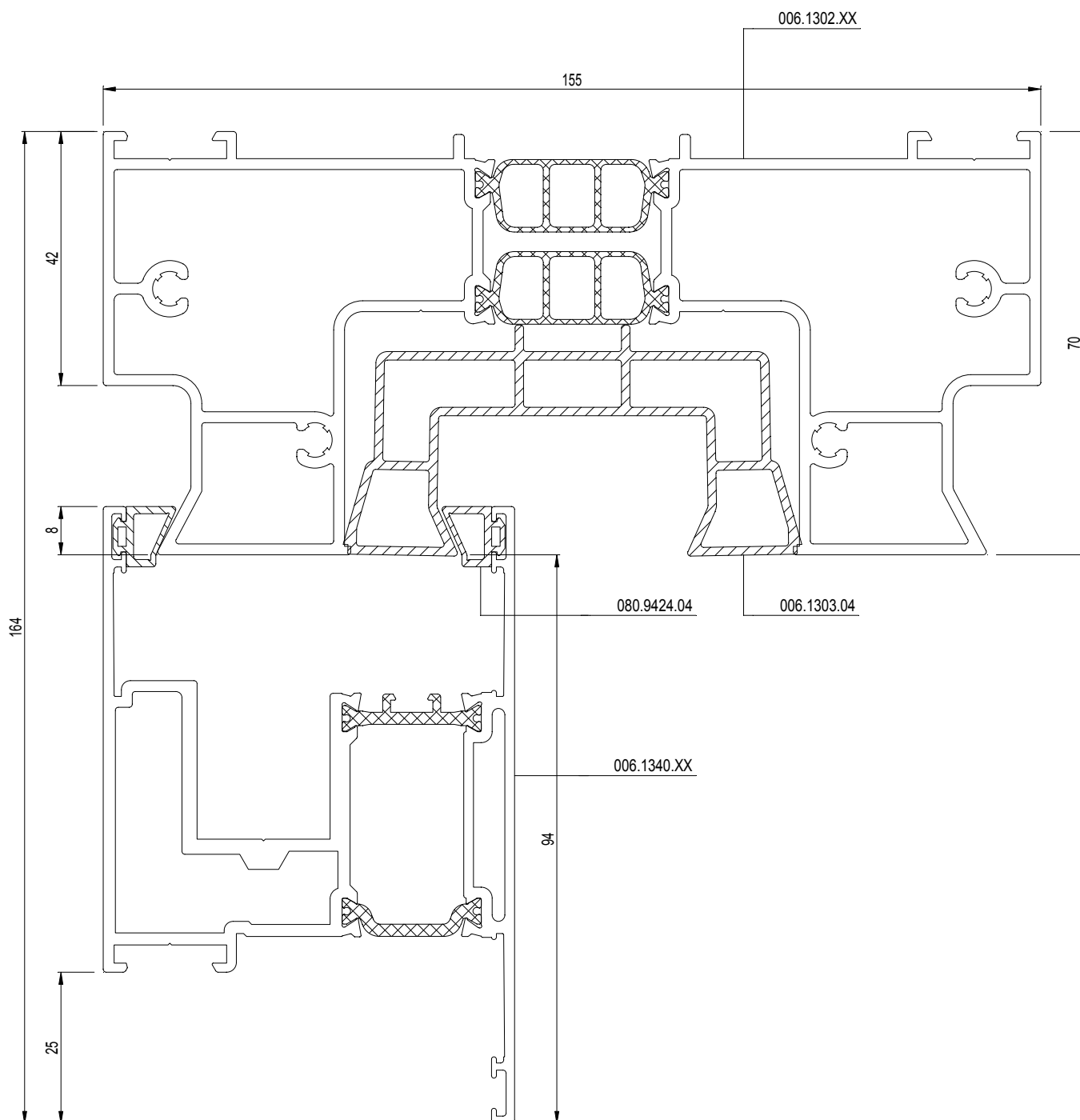
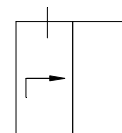

CP 155-LS

2-RAIL
2-RAIL
2-RAIL
2-RAIL



OPTIE B = HI
OPTION B = HI
OPTION B = HI
OPTION B = HI

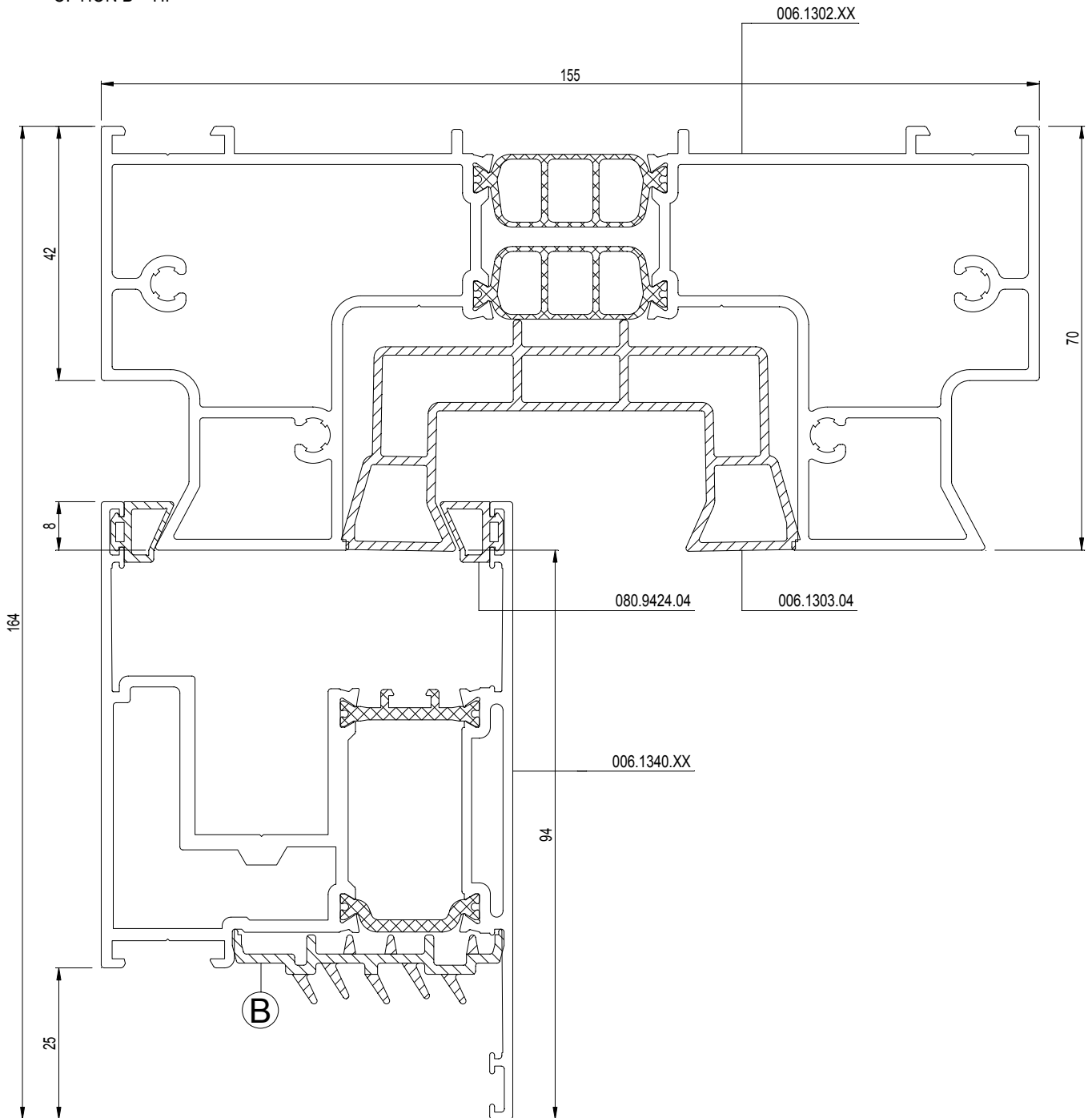
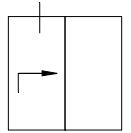

OPTIE A
OPTION A
OPTION A
OPTION A

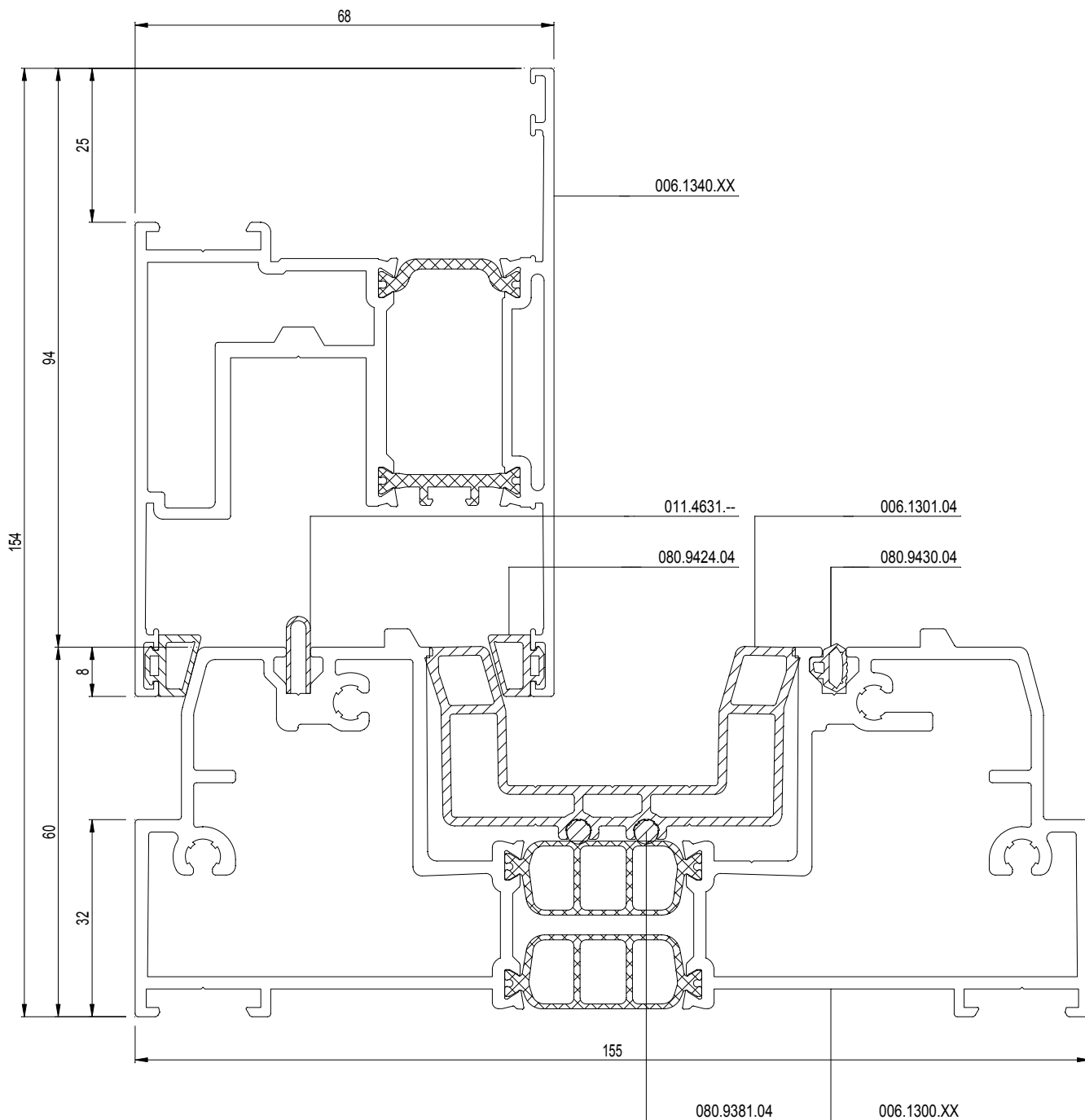
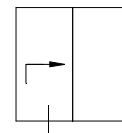

CP 155-LS

2-RAIL
2-RAIL
2-RAIL
2-RAIL



OPTIE C = HI
OPTION C = HI
OPTION C = HI
OPTION C = HI

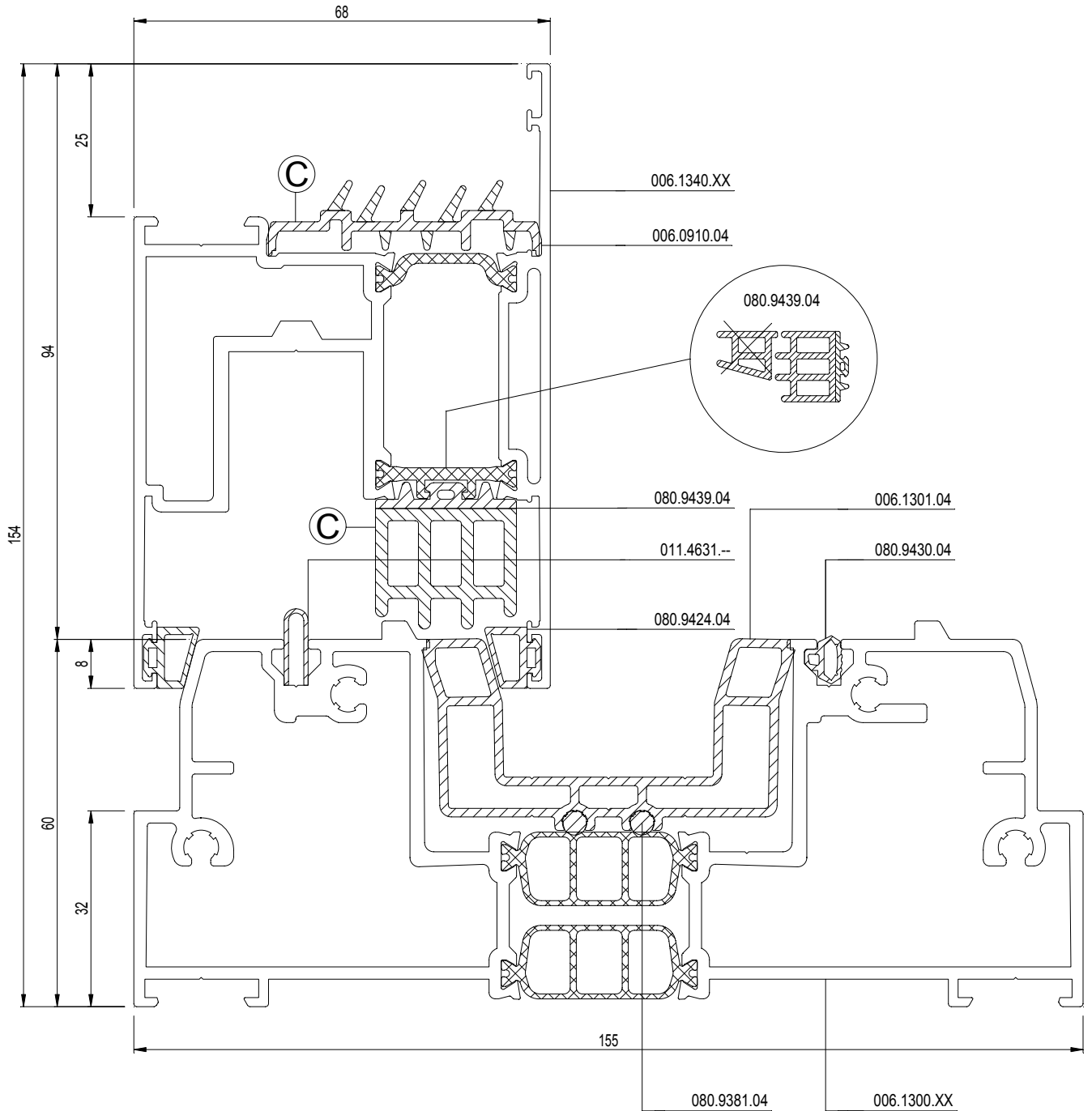
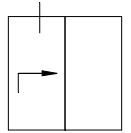

VARIANT - OPTIE B
VARIANTE - OPTION B
VARIANT - OPTION B
VARIANTE - OPTION B

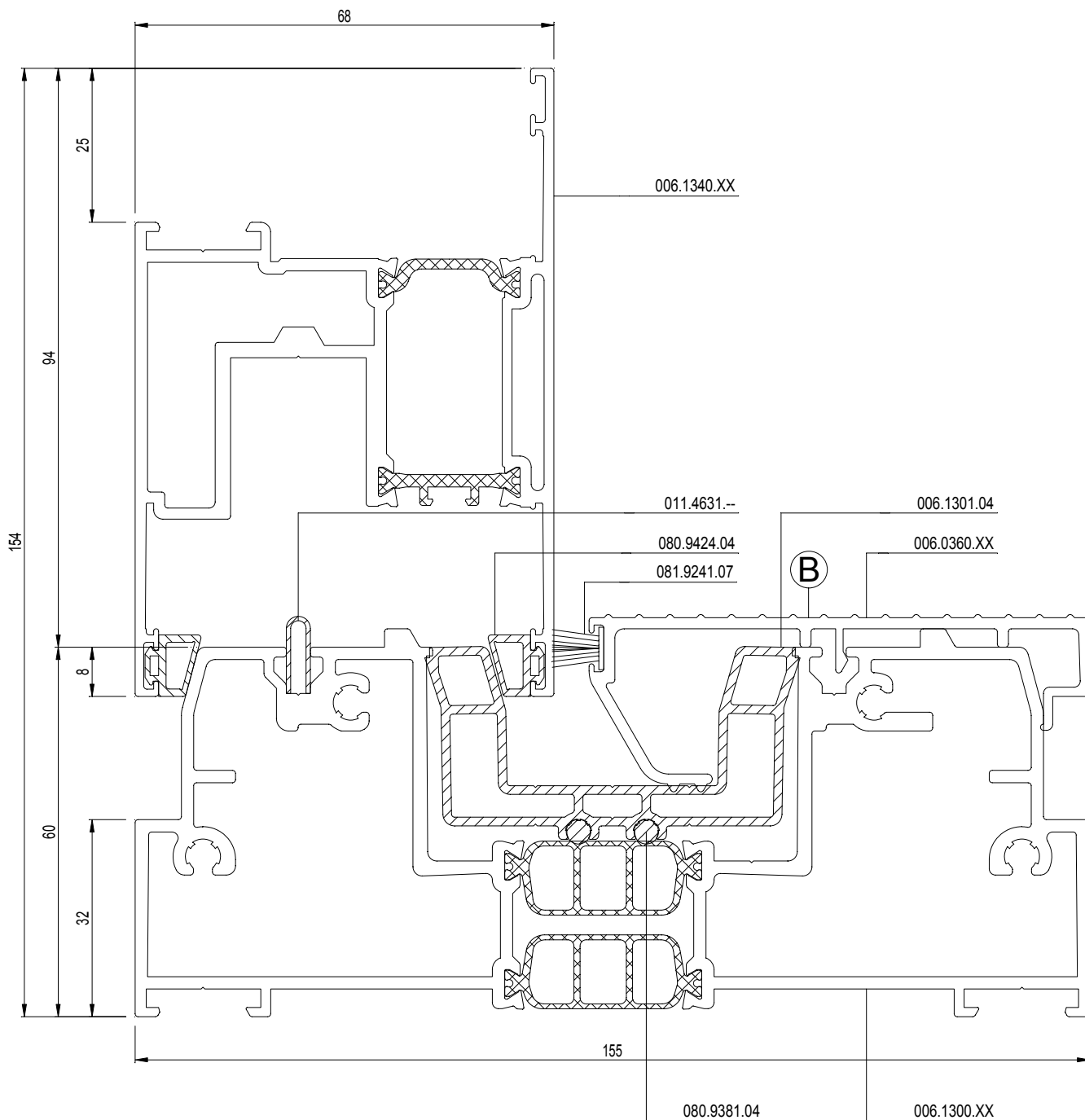
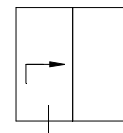

CP 155-LS

2-RAIL
2-RAIL
2-RAIL
2-RAIL



VARIANT - OPTIE D = HI
VARIANTE - OPTION D = HI
VARIANT - OPTION D = HI
VARIANTE - OPTION D = HI

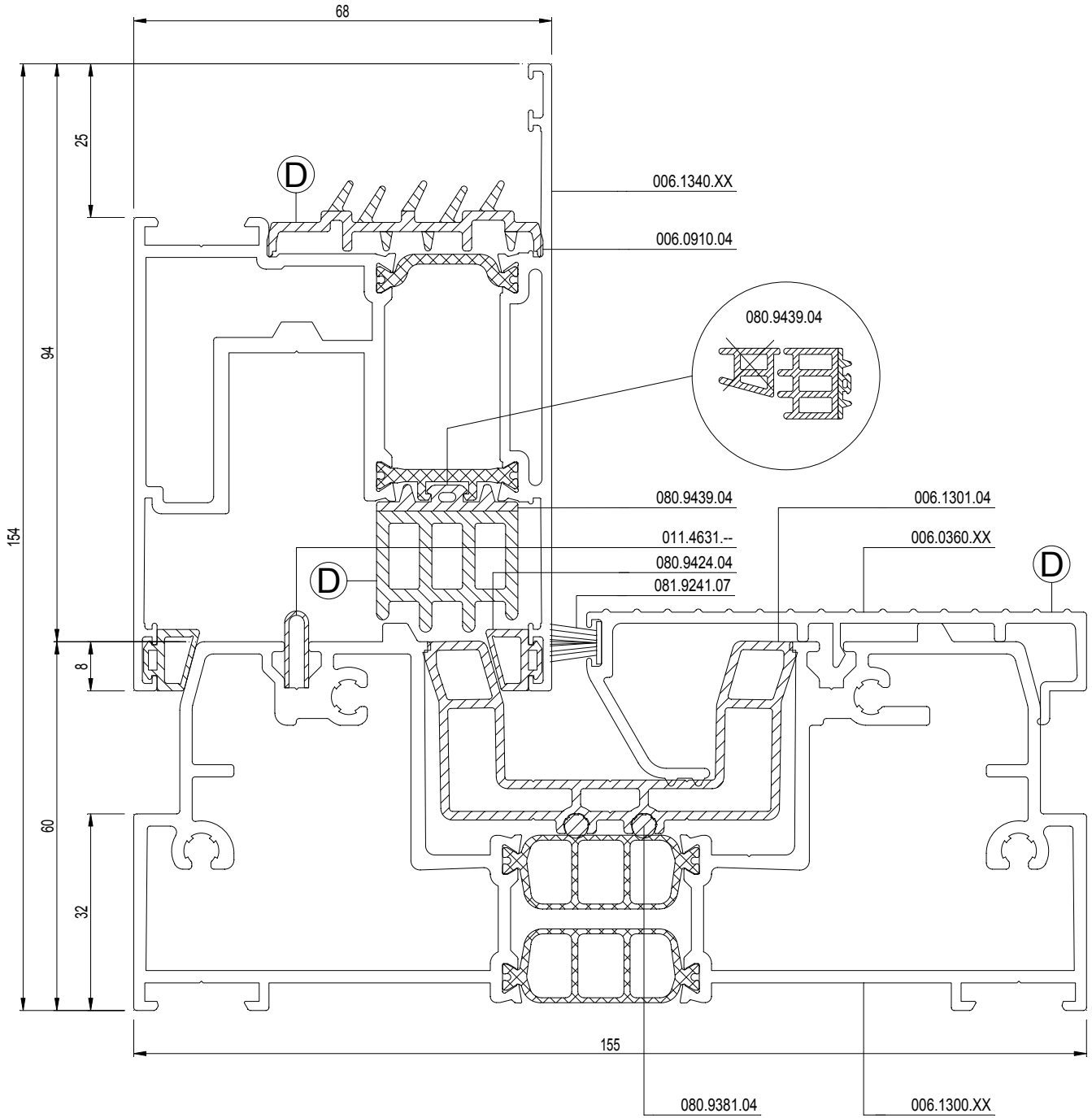
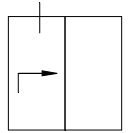

CP 155-LS

2-RAIL
2-RAIL
2-RAIL
2-RAIL

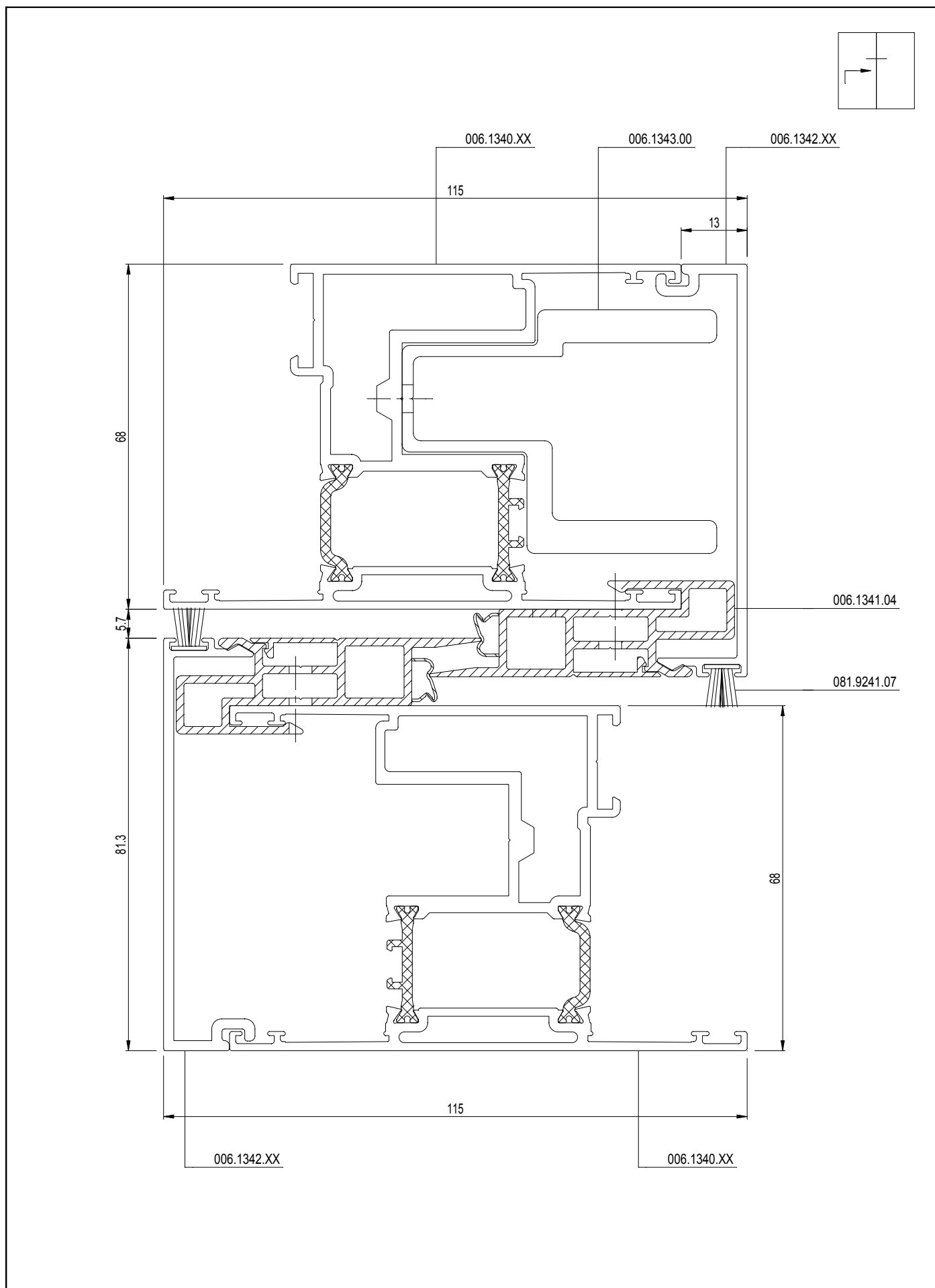

CP 155-LS

2-RAIL
2-RAIL
2-RAIL
2-RAIL

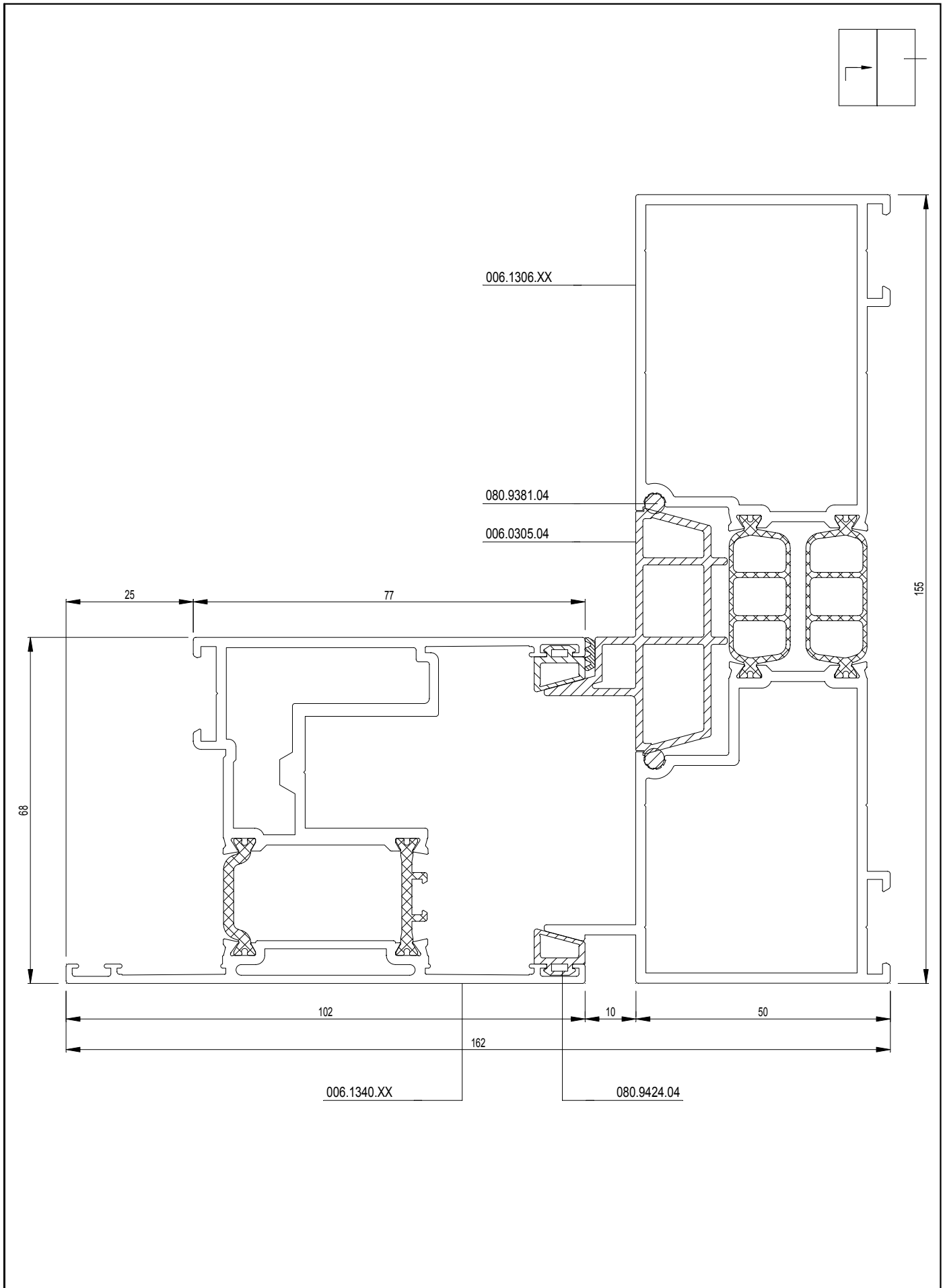
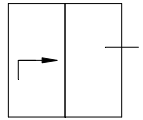

CP 155-LS

2-RAIL
2-RAIL
2-RAIL
2-RAIL

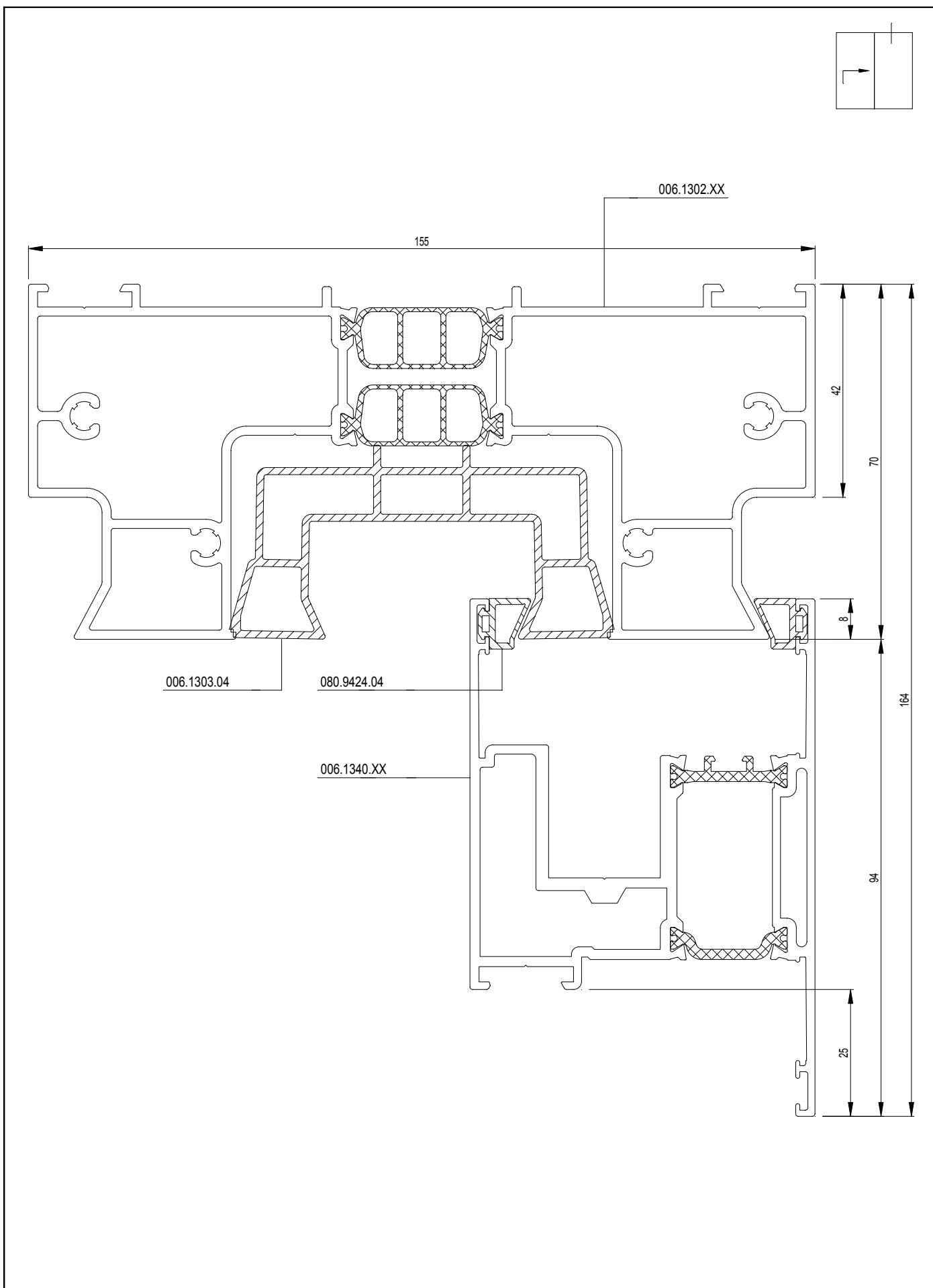

CP 155-LS

2-RAIL
2-RAIL
2-RAIL
2-RAIL

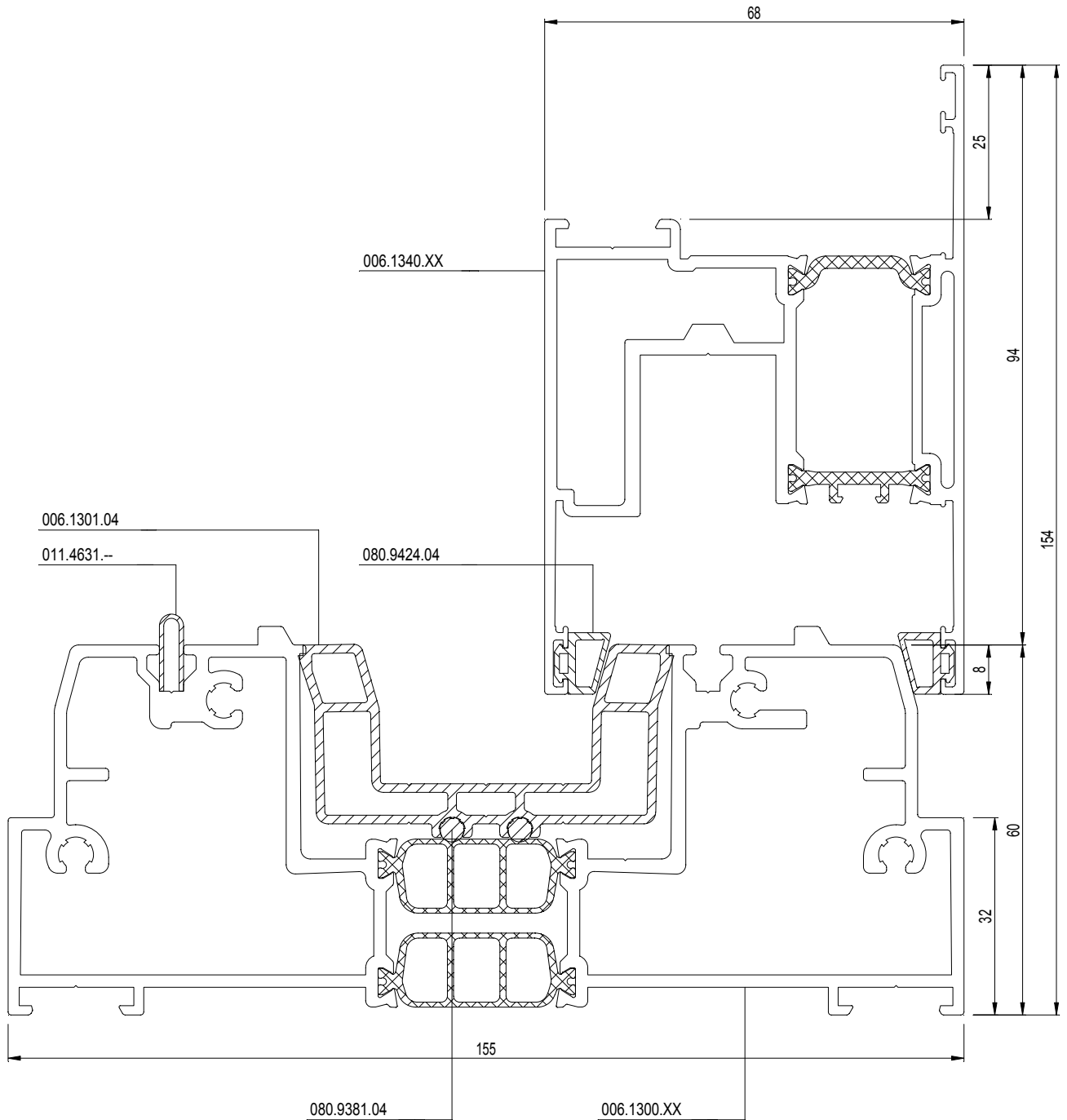
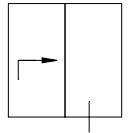

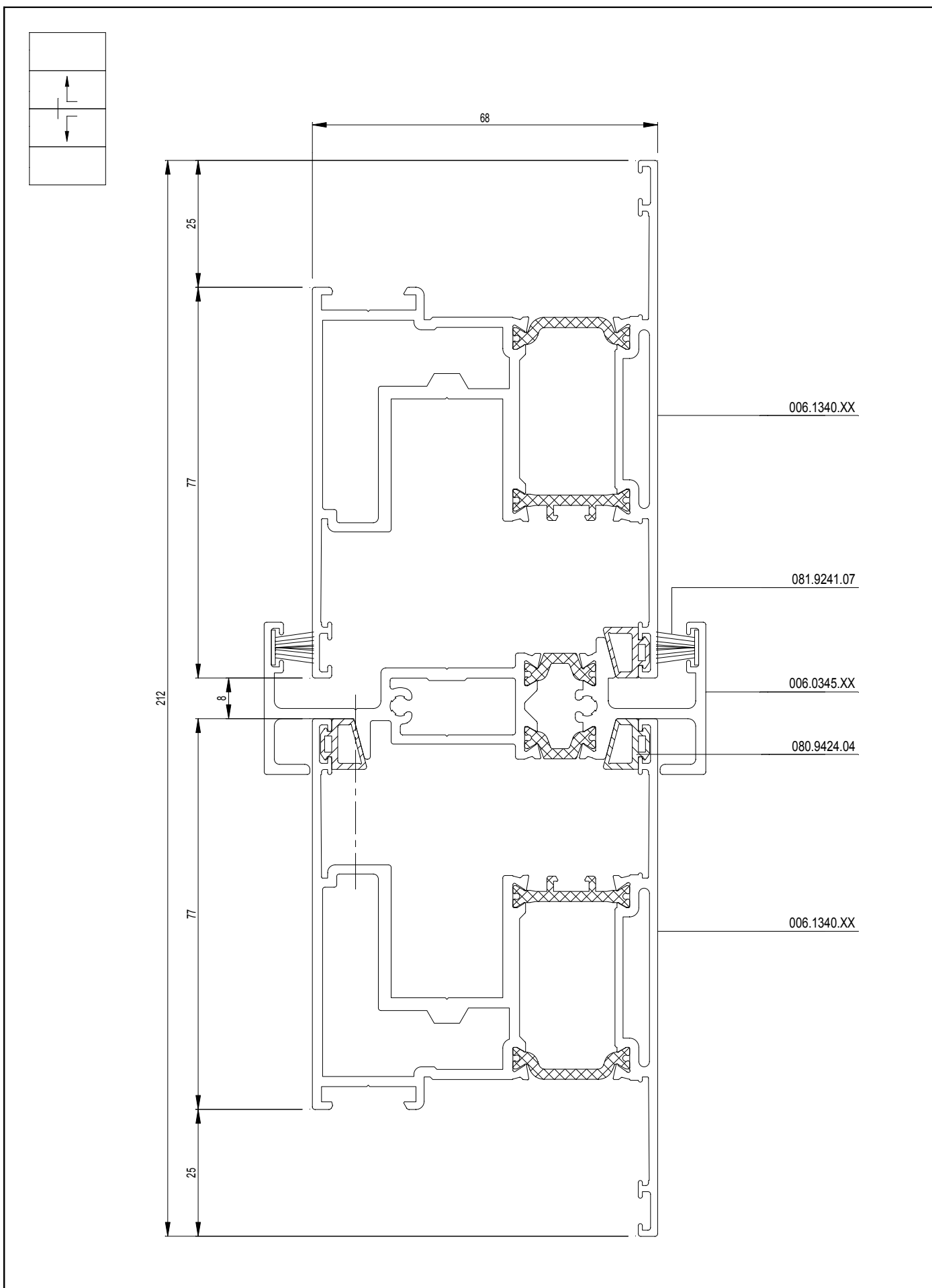

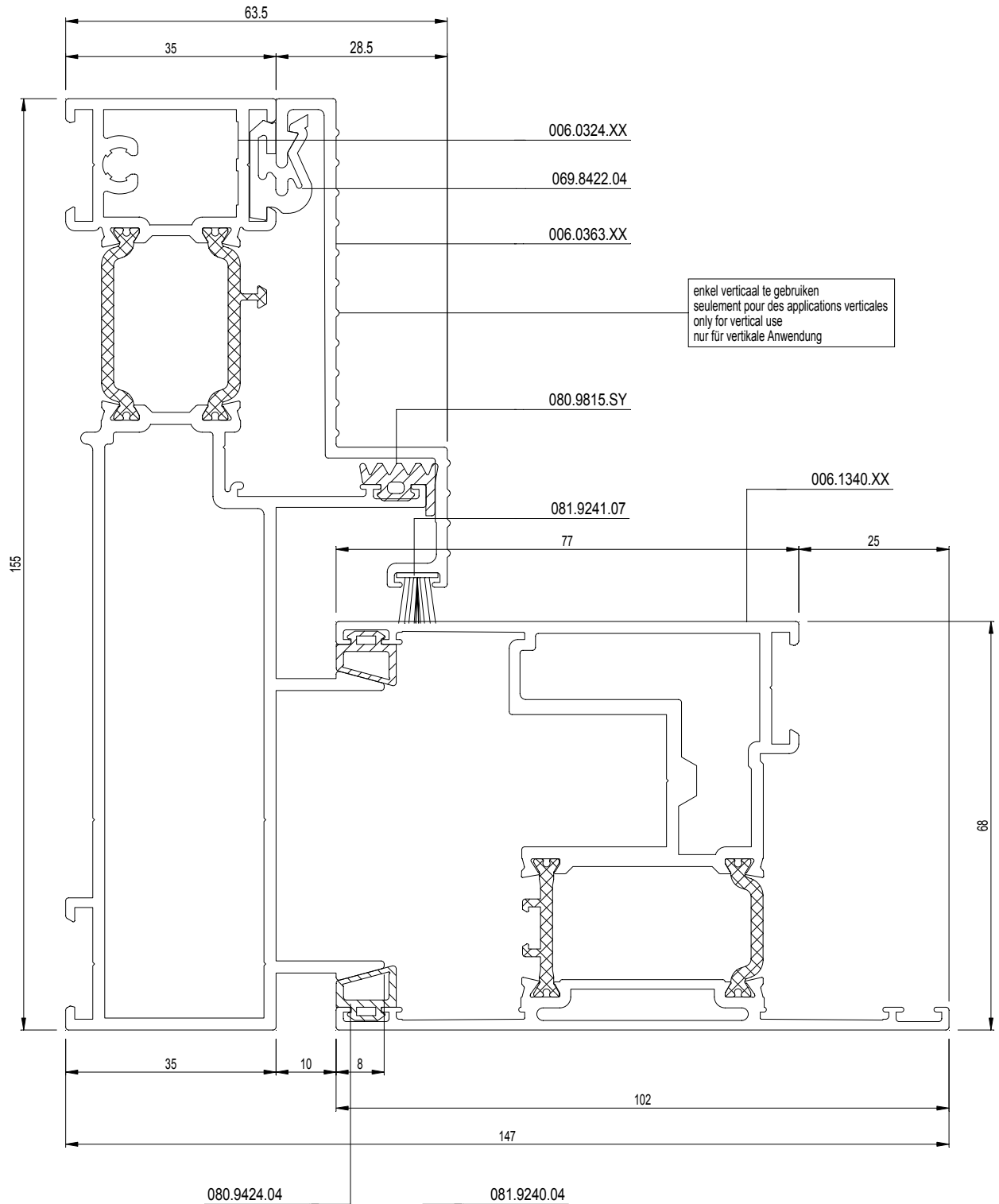
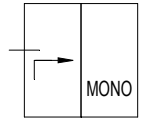

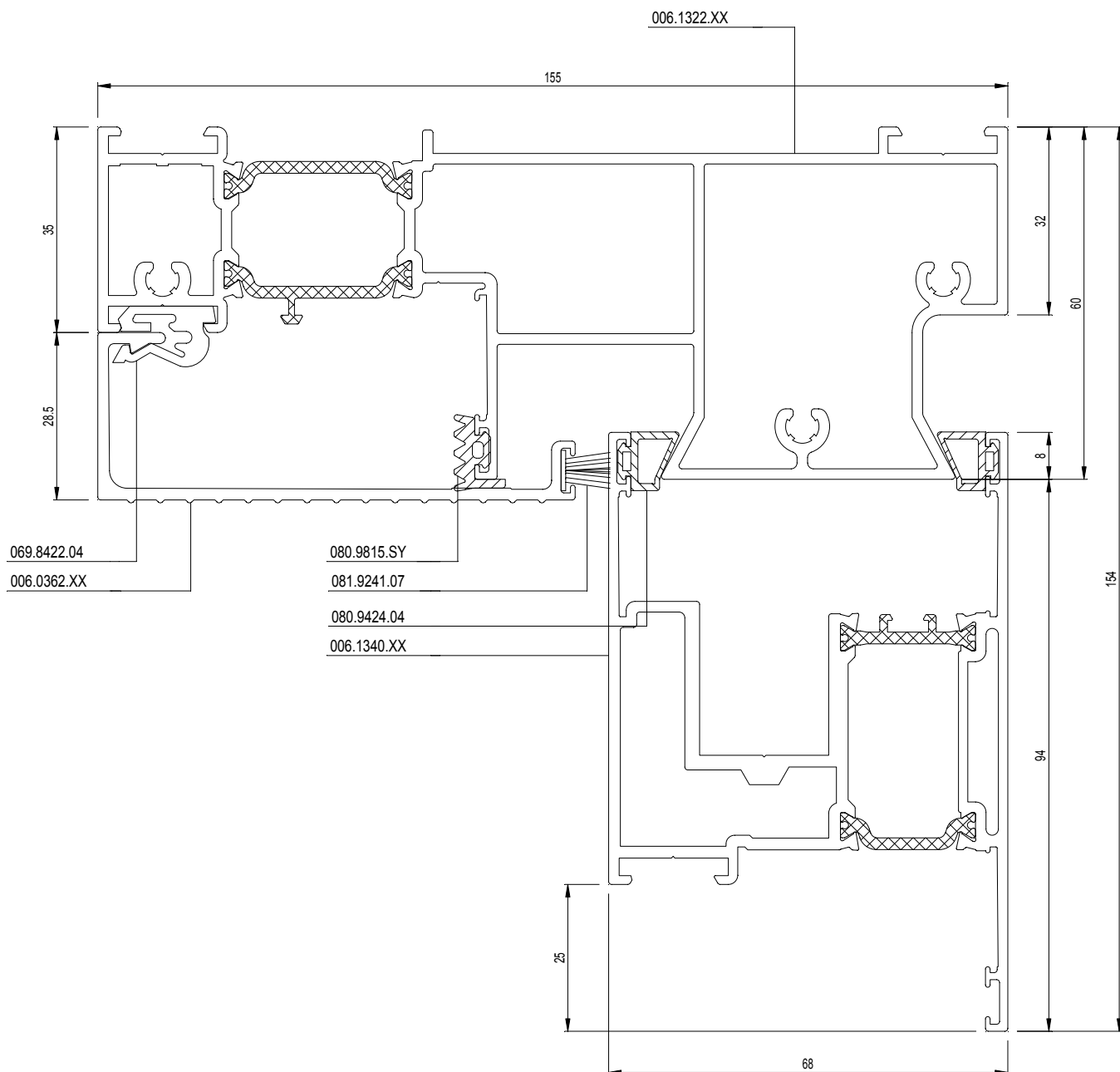
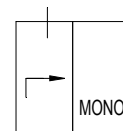

CP 155-LS

MONORAIL
MONORAIL
MONORAIL
MONORAIL

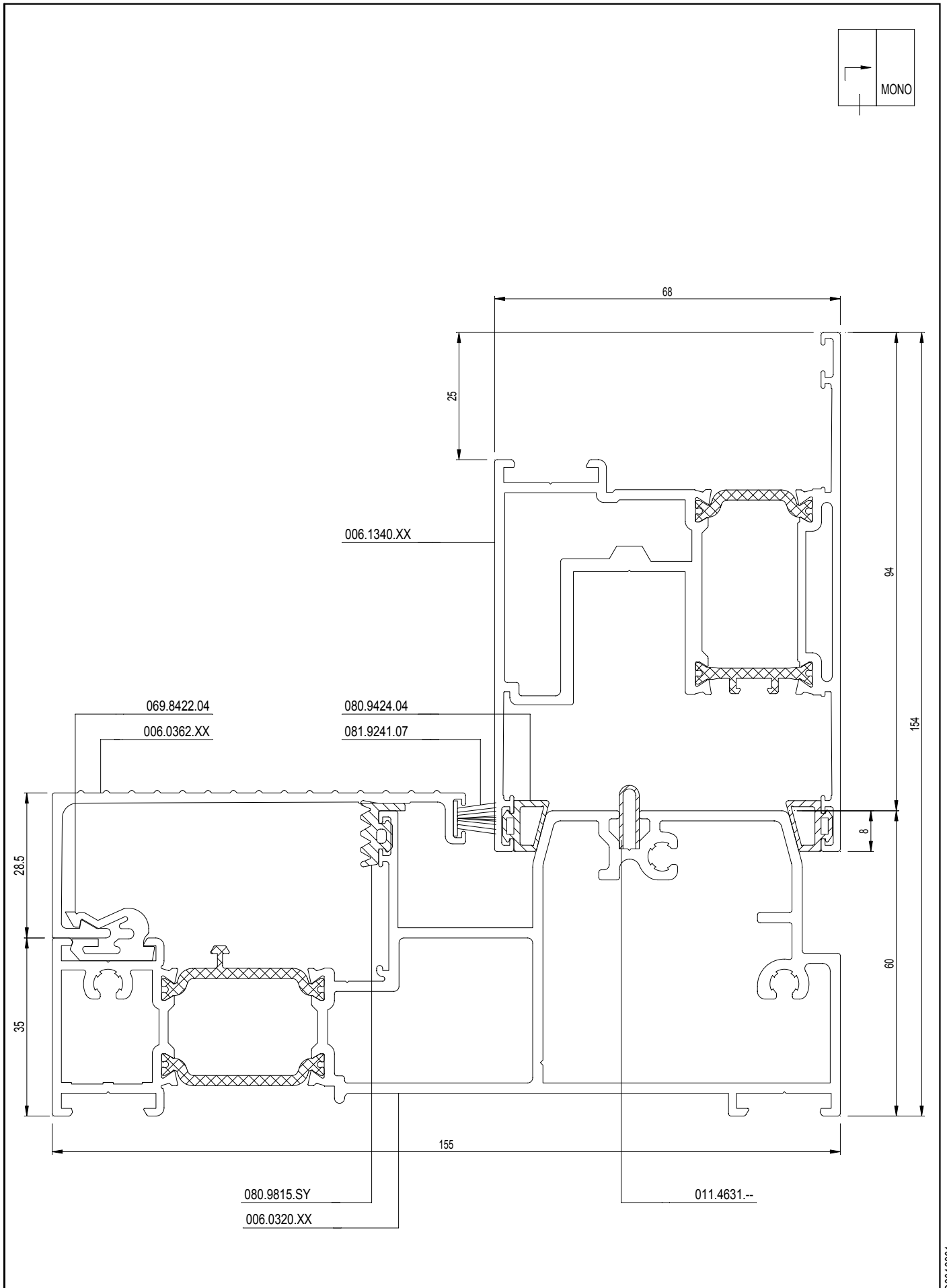
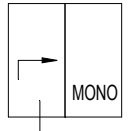

Doorsnedetekeningen
Sections des noeuds
Section drawings
Profilkombinationen

34.D.039
02/2009

D0013901

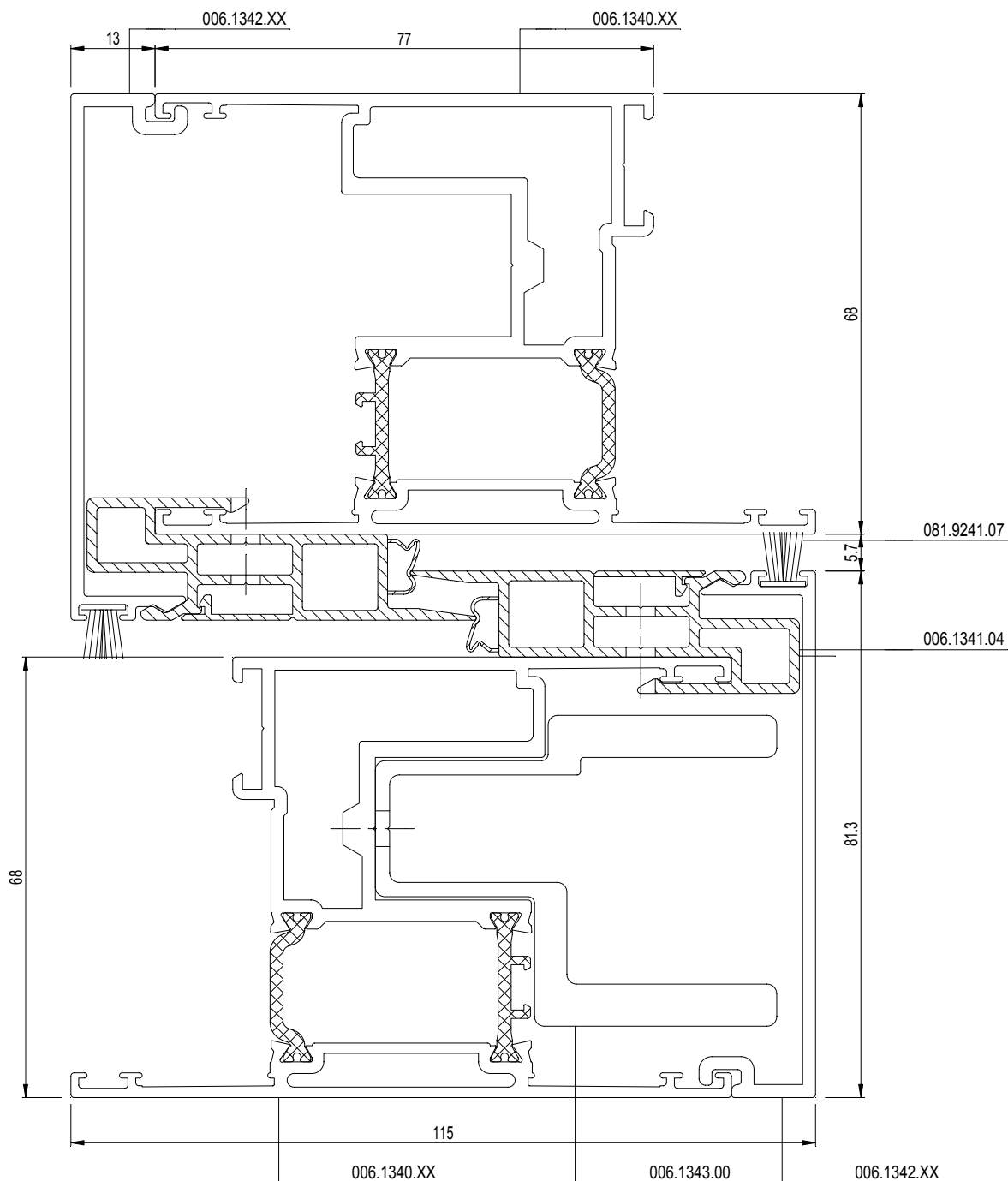
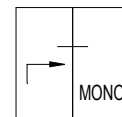

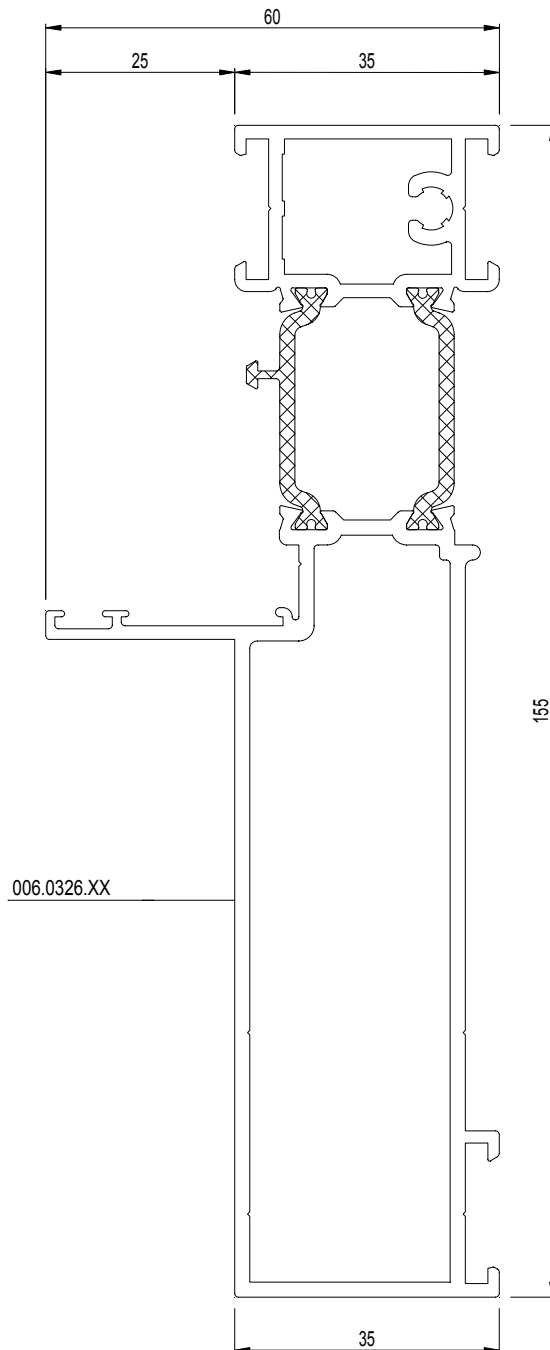
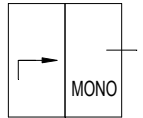

CP 155-LS

MONORAIL
MONORAIL
MONORAIL
MONORAIL

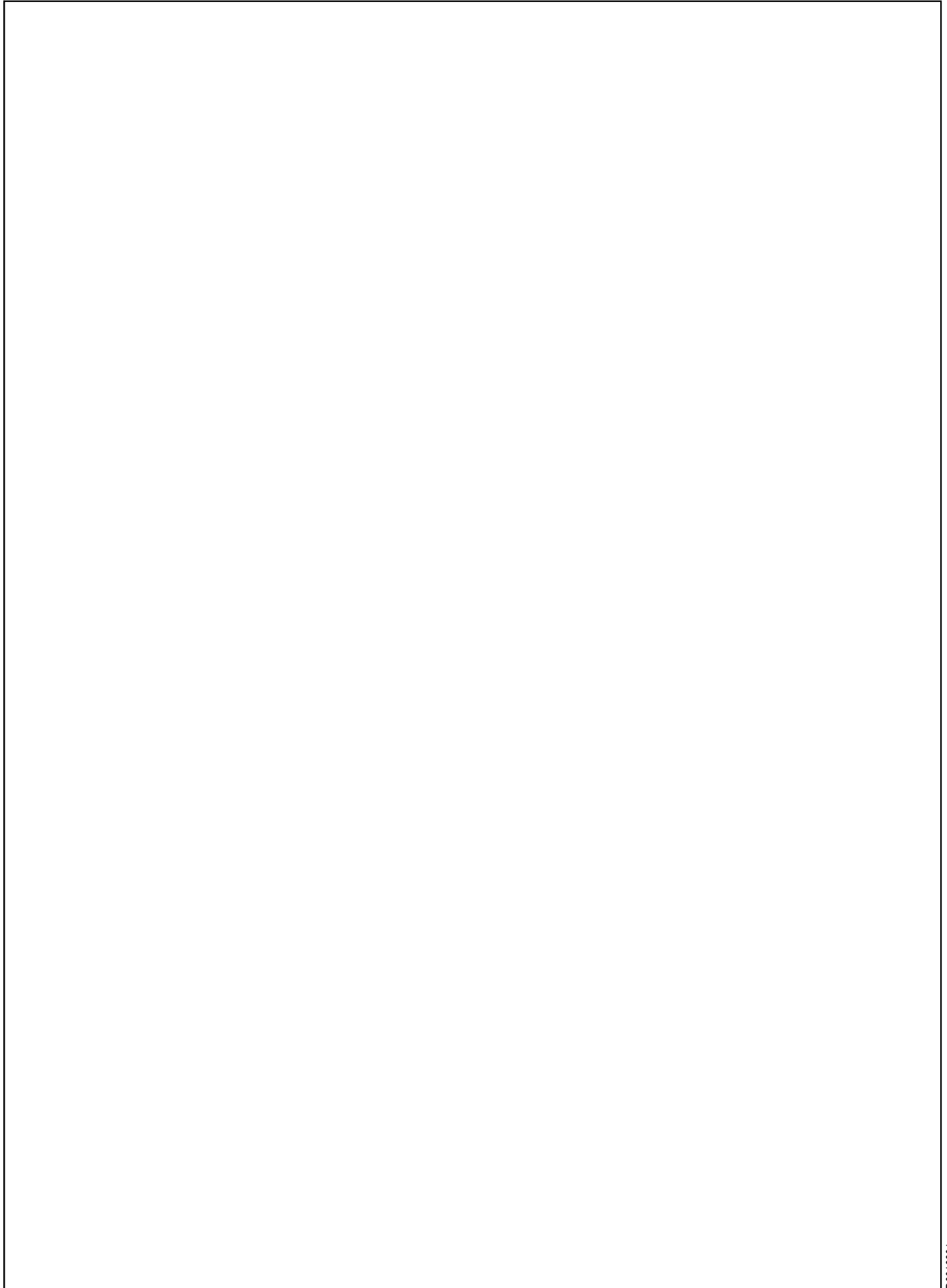

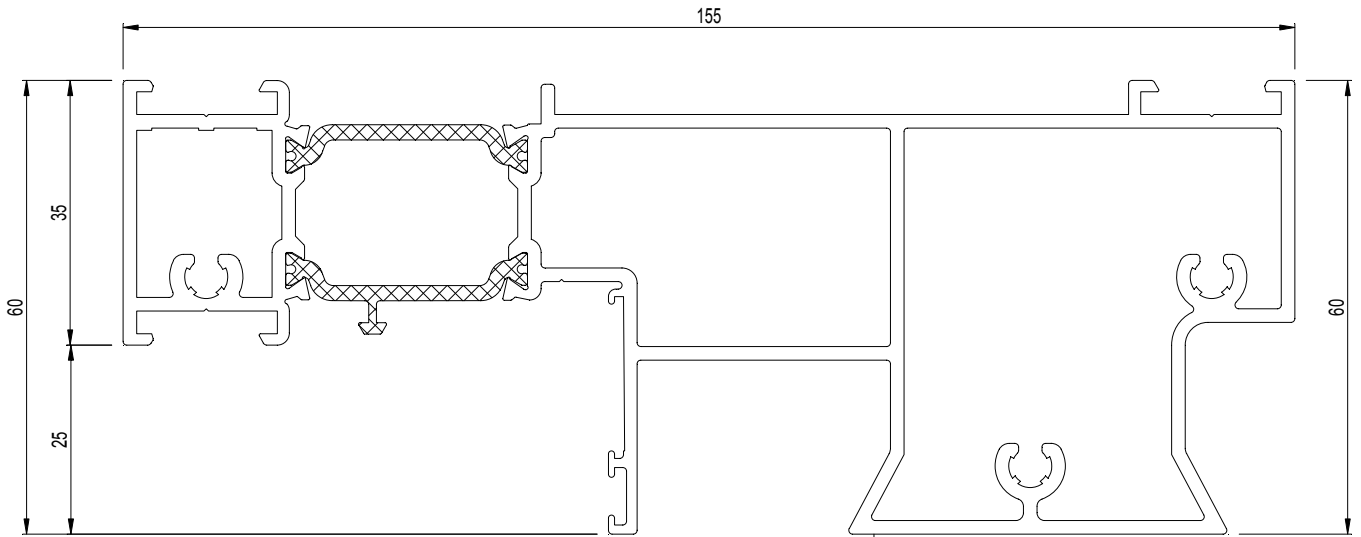
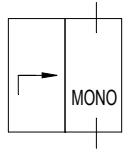

006.1322.XX

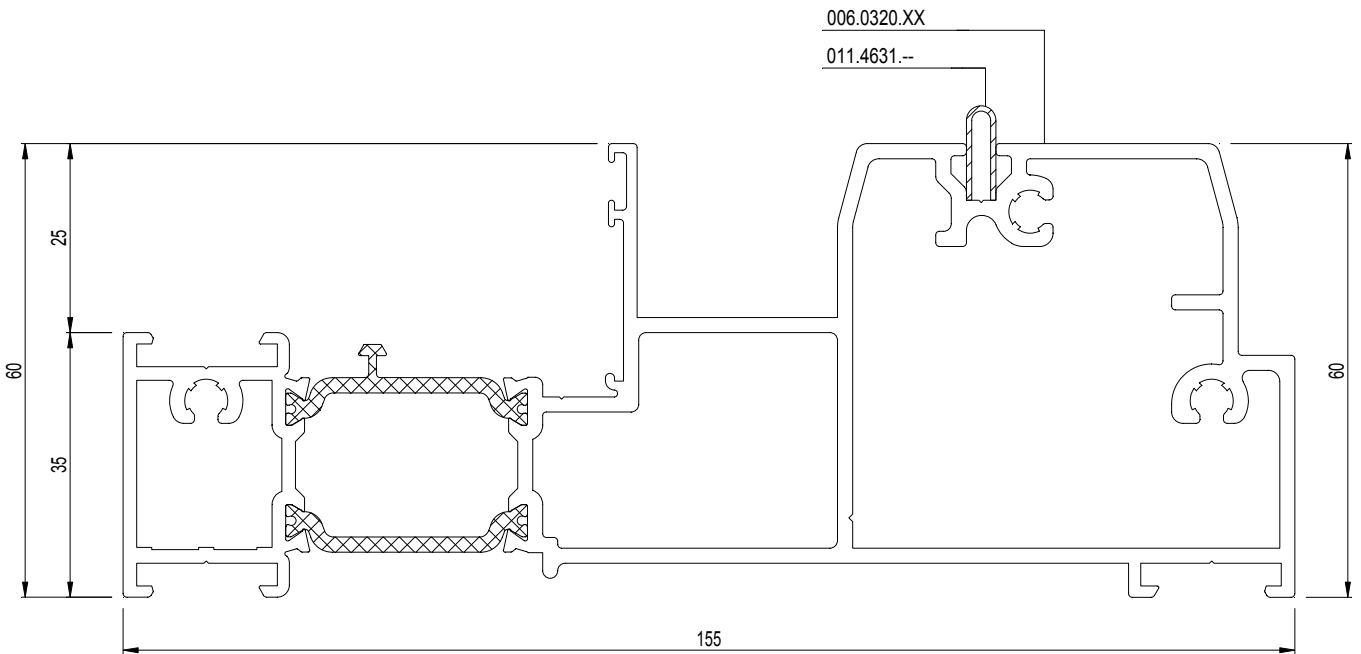

006.0320.XX

011.4631.--

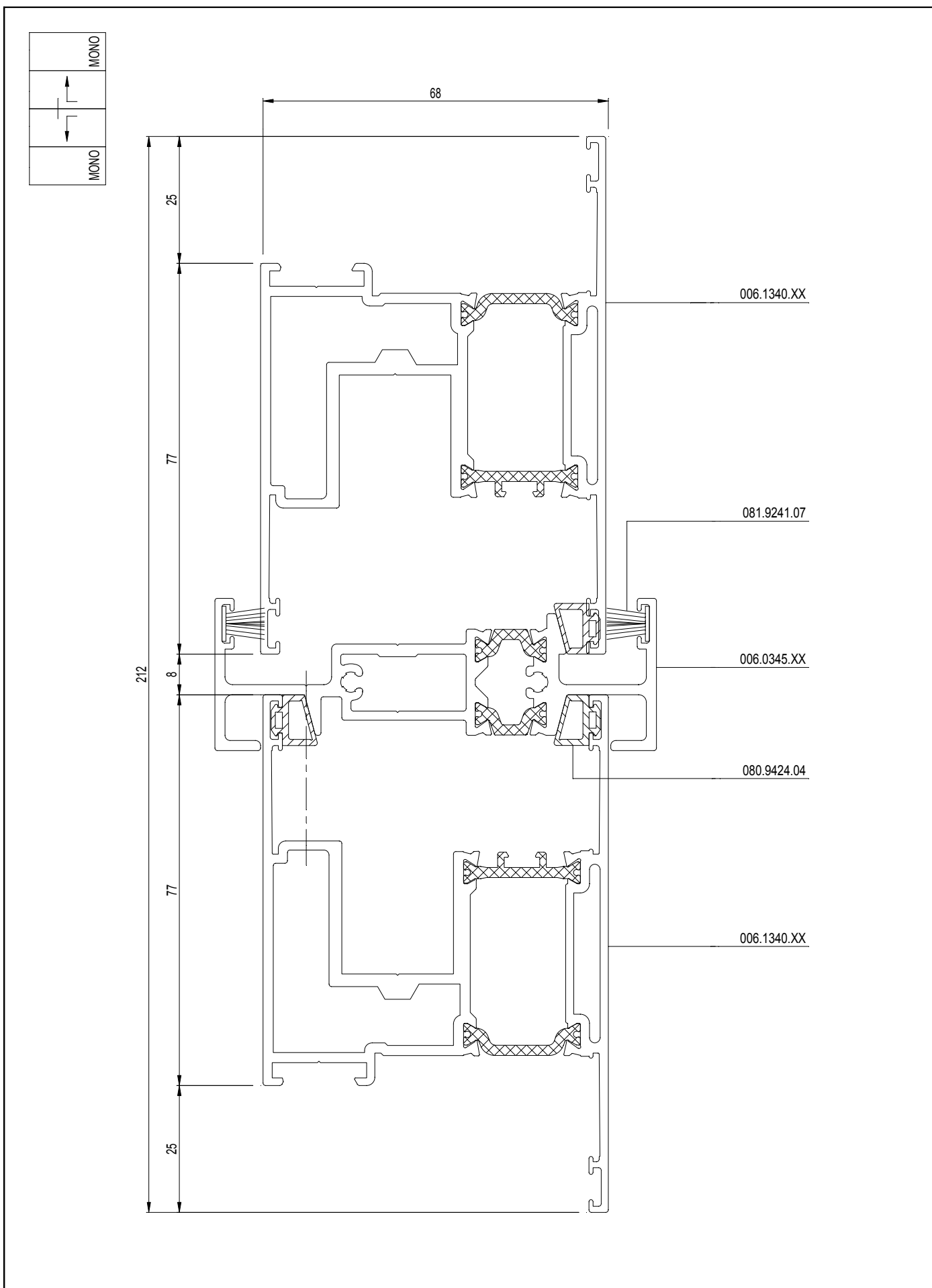

CP 155-LS

3-RAIL
3-RAIL
3-RAIL
3-RAIL

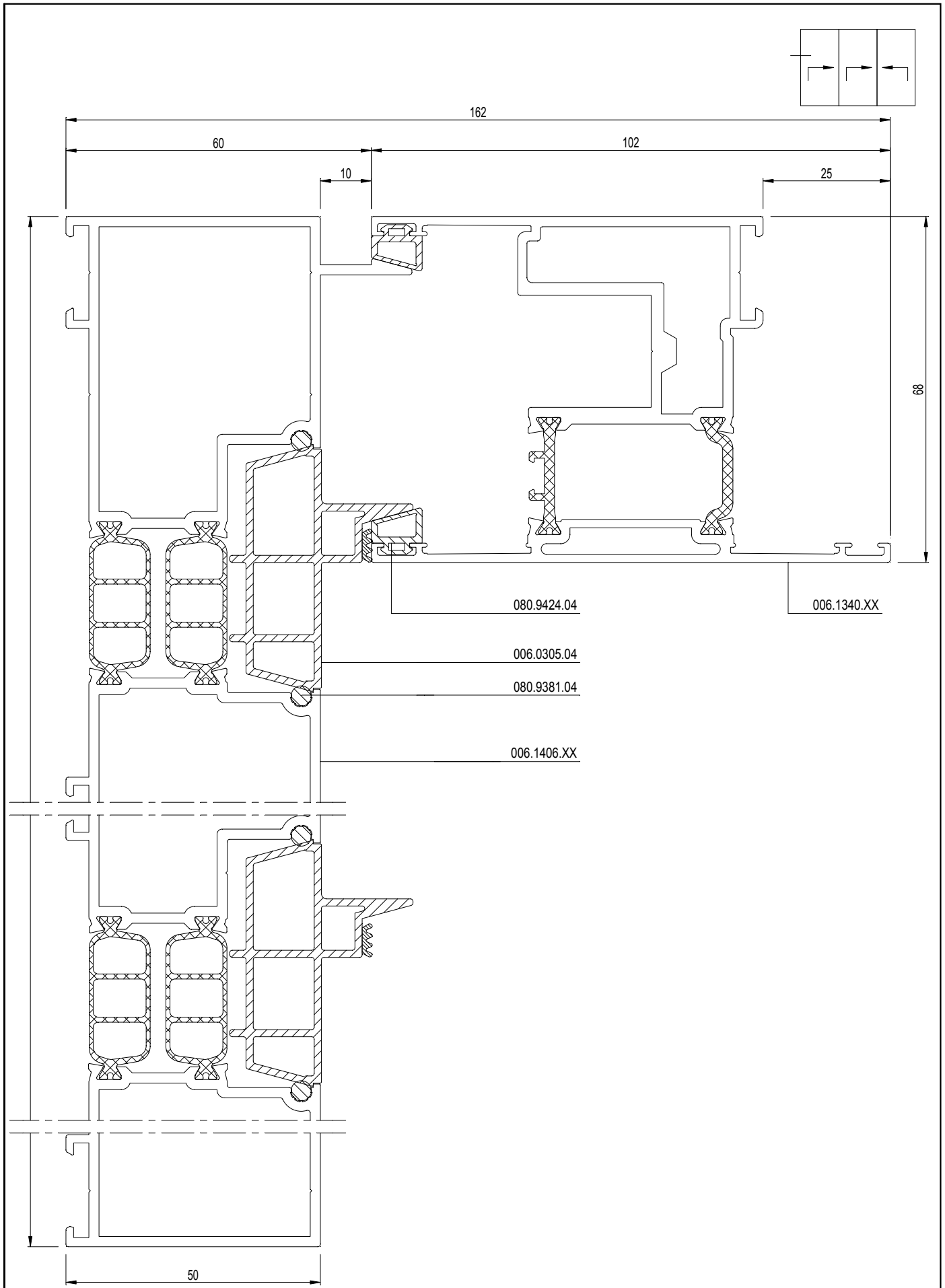

Doorsnedetekeningen
Sections des noeuds
Section drawings
Profilkombinationen

34.D.045
02/2009

D0046245

CP 155-LS

3-RAIL
3-RAIL
3-RAIL
3-RAIL

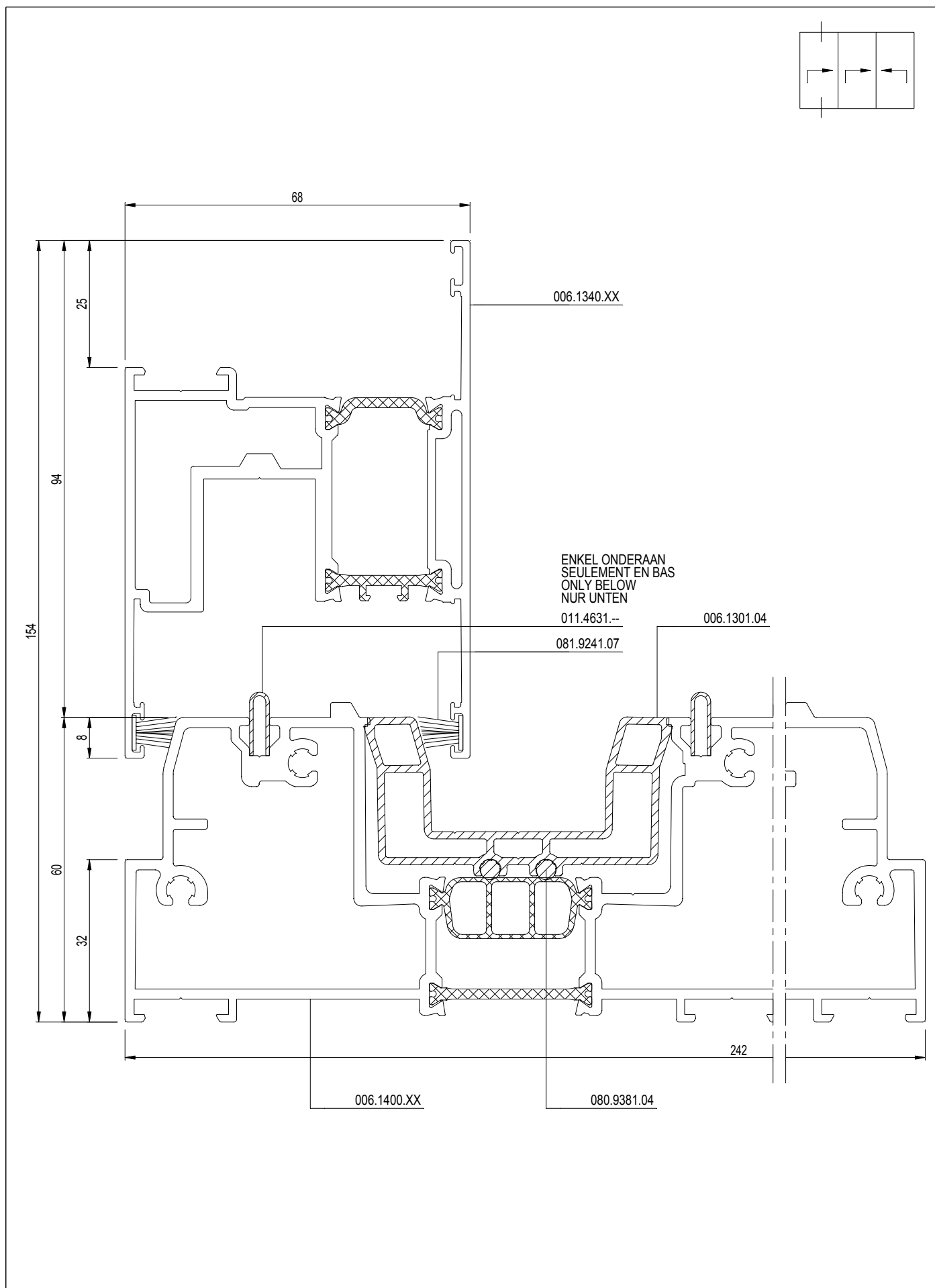

Doorsnedetekeningen
Sections des noeuds
Section drawings
Profilkombinationen

34.D.046
02/2009

D0046252

3-RAIL
3-RAIL
3-RAIL
3-RAIL

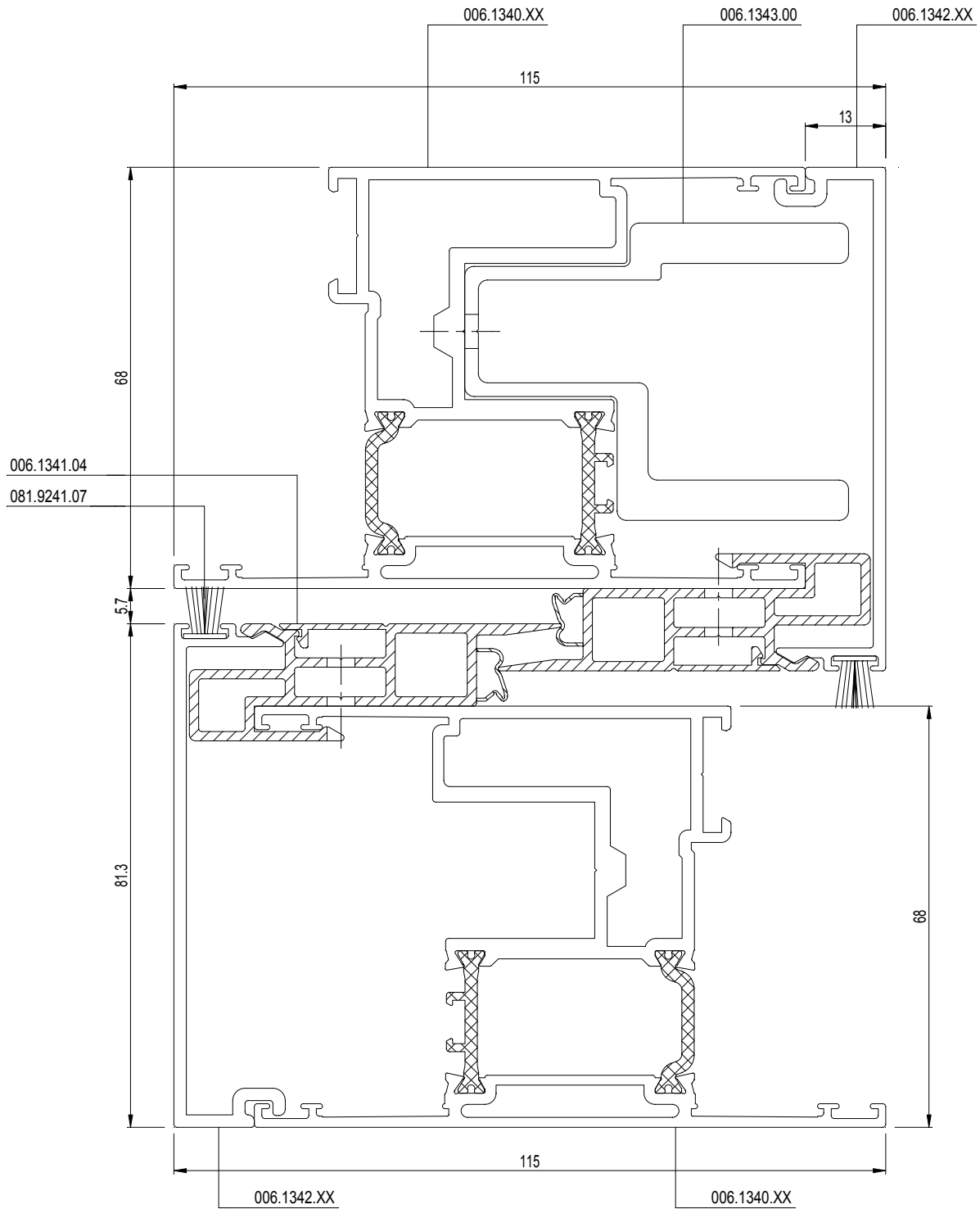
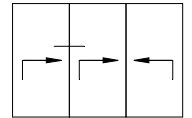

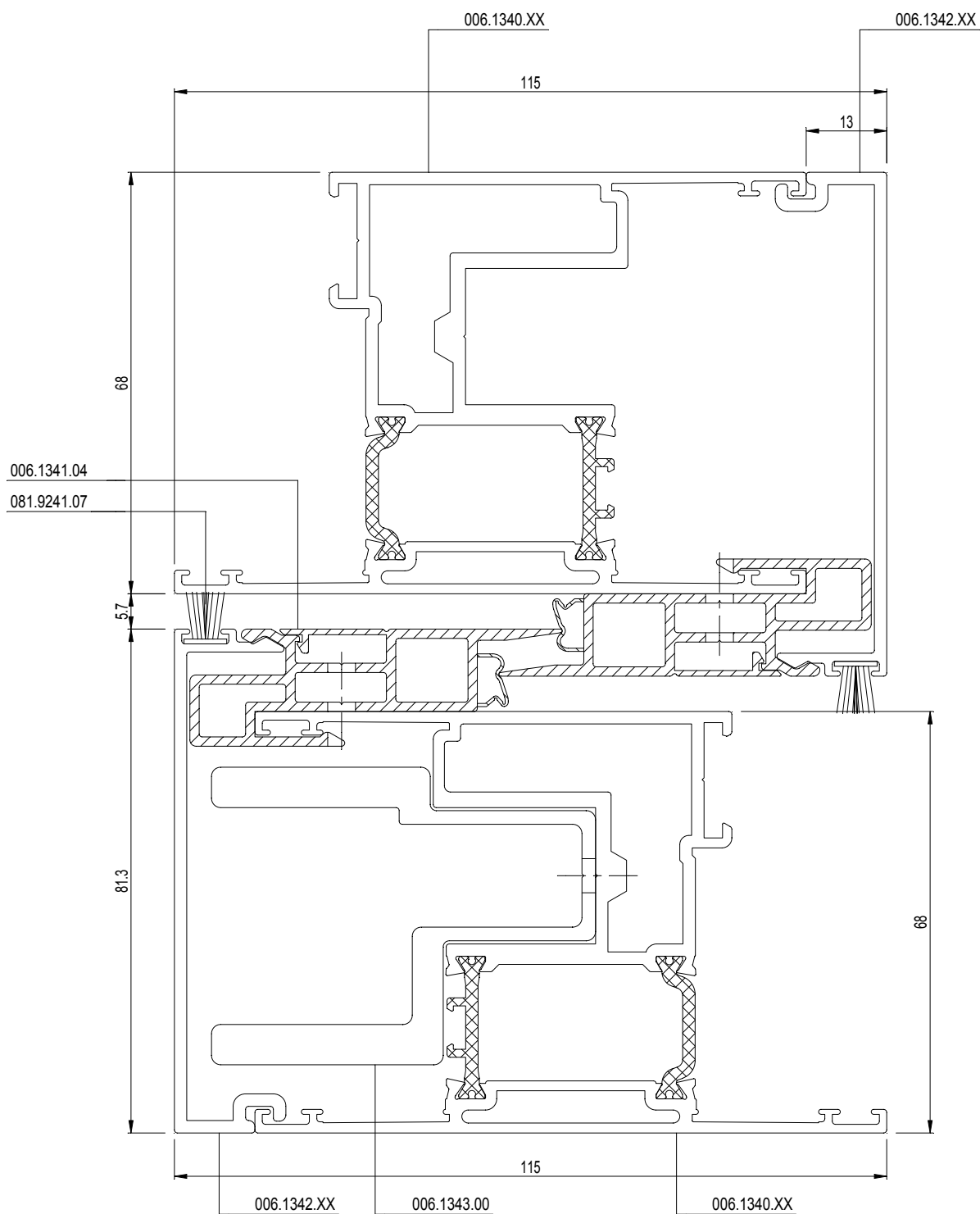
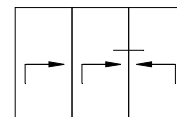

CP 155-LS

3-RAIL
3-RAIL
3-RAIL
3-RAIL

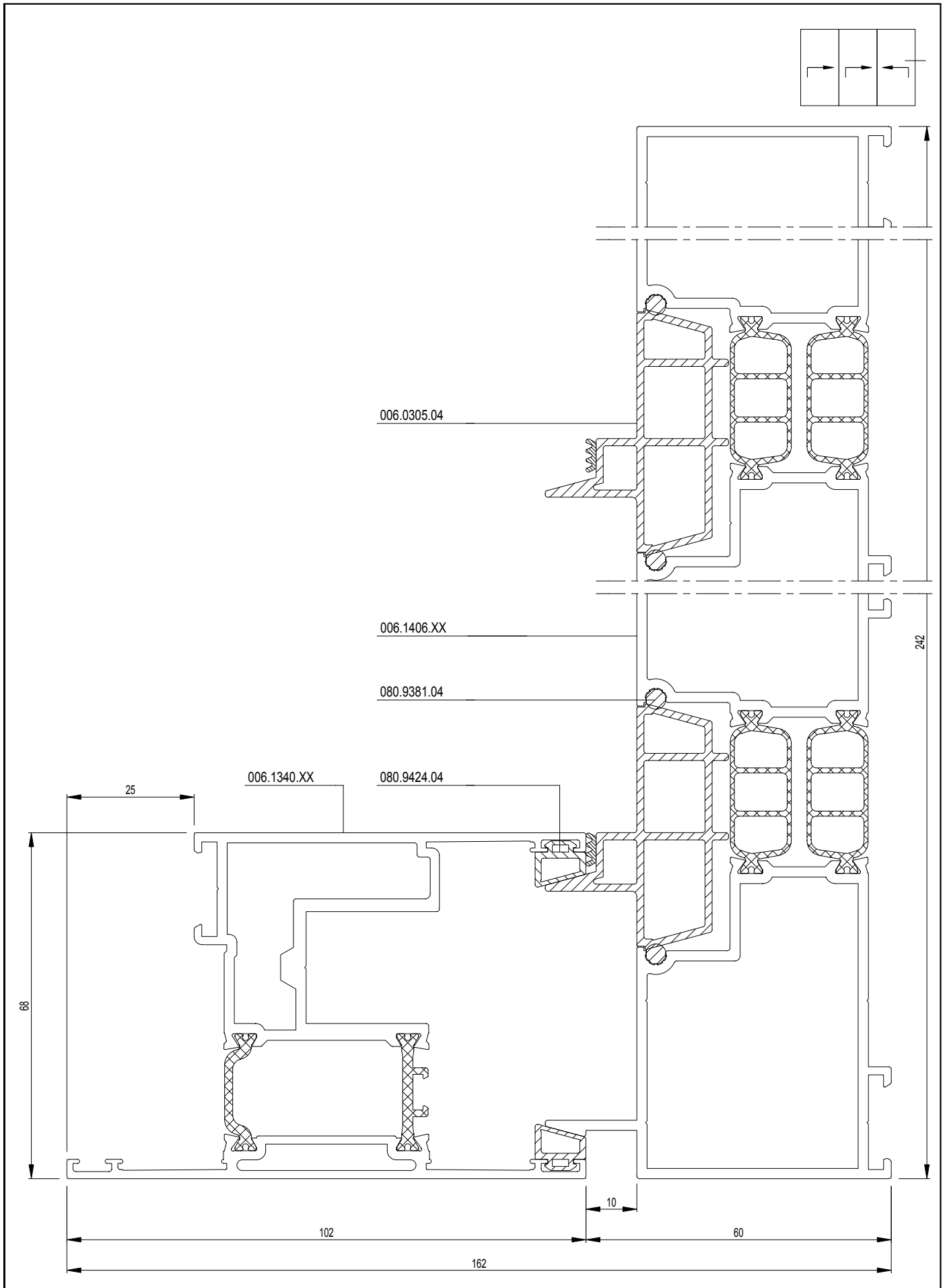

Doorsnedetekeningen
Sections des noeuds
Section drawings
Profilkombinationen

34.D.049
02/2009

D0046257

CP 155-LS

2-RAIL QXQ
2-RAIL QXQ
2-RAIL QXQ
2-RAIL QXQ

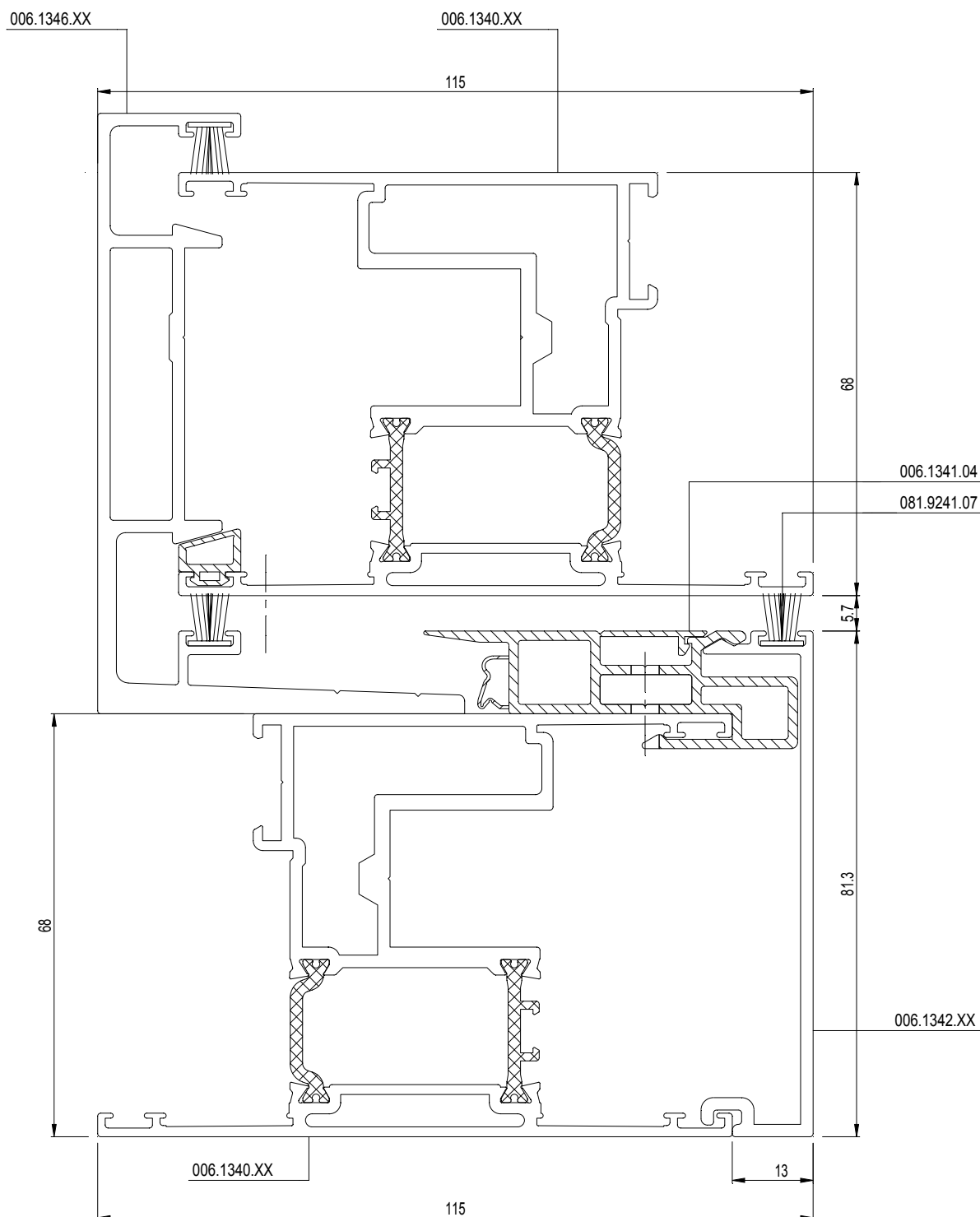
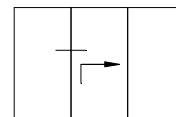

CP 155-LS

2-RAIL FLAT BOTTOM
2-RAIL FLAT BOTTOM
2-RAIL FLAT BOTTOM
2-RAIL FLAT BOTTOM

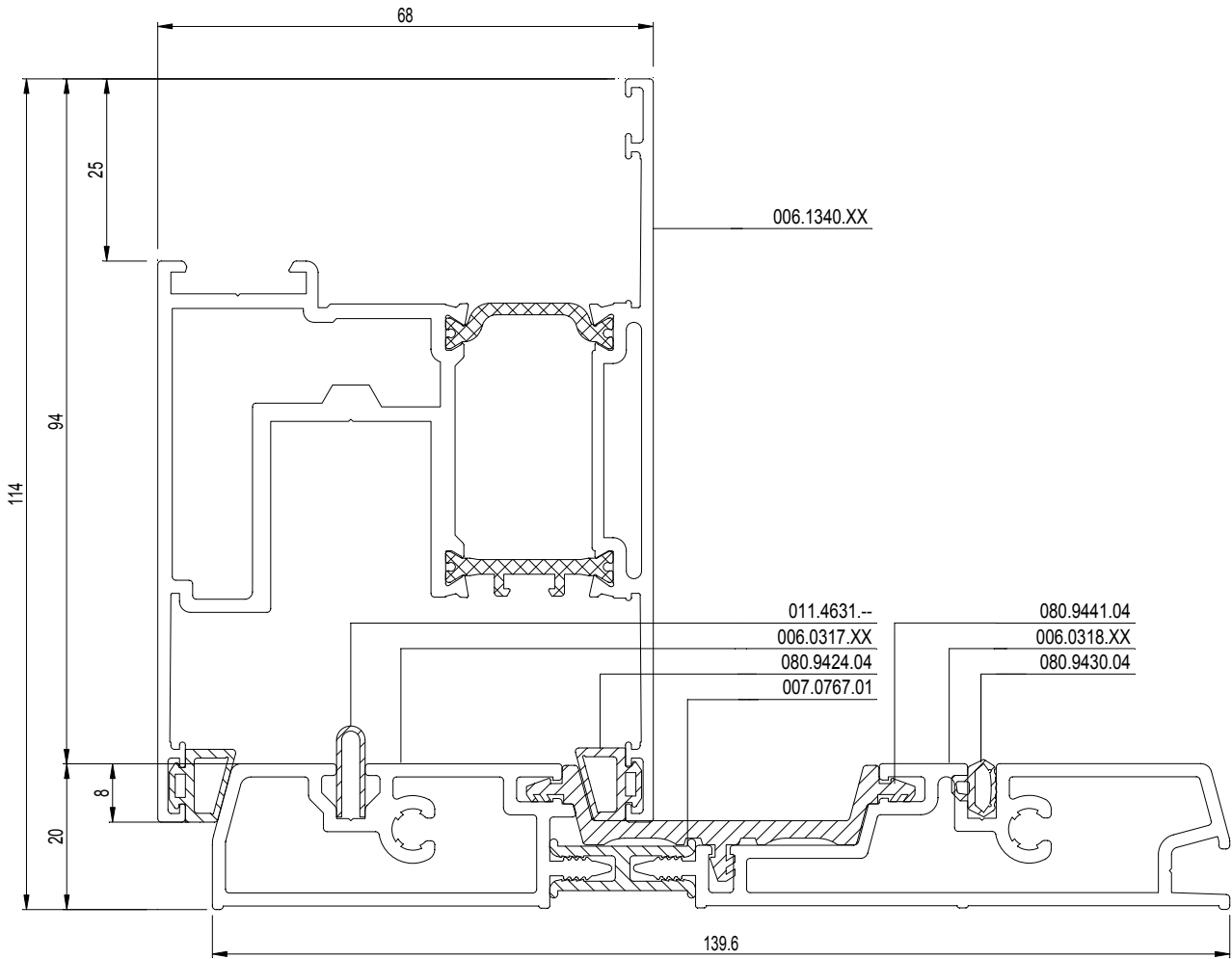
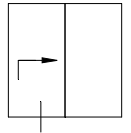

CP 155-LS

2-RAIL FLAT BOTTOM
2-RAIL FLAT BOTTOM
2-RAIL FLAT BOTTOM
2-RAIL FLAT BOTTOM



E

Werktekeningen

Coupes et débits

Work drawings

Werkzeichnungen

CP 155

2-RAIL XQ
2-RAIL XQ
2-RAIL XQ
2-RAIL XQ



VLEUGELGEWICHT POIDS DU VANTAIL WEIGHT OF THE VENT FLÜGELGEWICHT	MAX. 250KG
---	------------

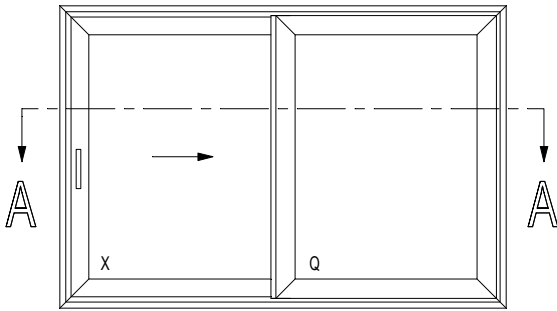

A - A

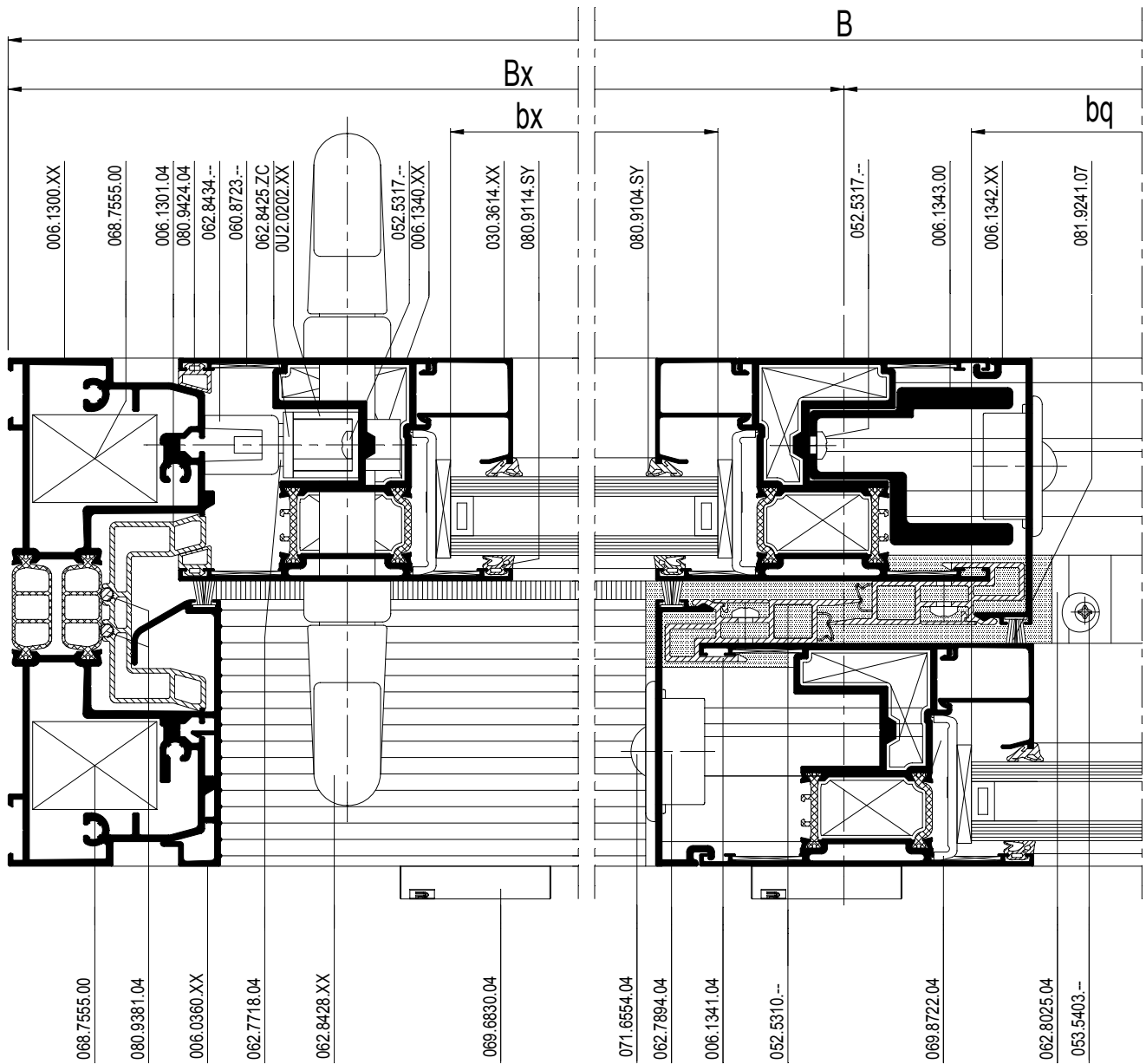

schaal - échelle
 Maßstab - scale
 1/2

D0013911

CP 155

2-RAIL XQ
 2-RAIL XQ
 2-RAIL XQ
 2-RAIL XQ



		or		or	
	---	or	---	or	097.0437.00

X : PRIMARY SLIDING VENT
 Q : FIXED VENT
 O : SECONDARY SLIDING VENT

		or	
	095.A700.00	or	095.B300.00
	095.A730.00		095.B323.00

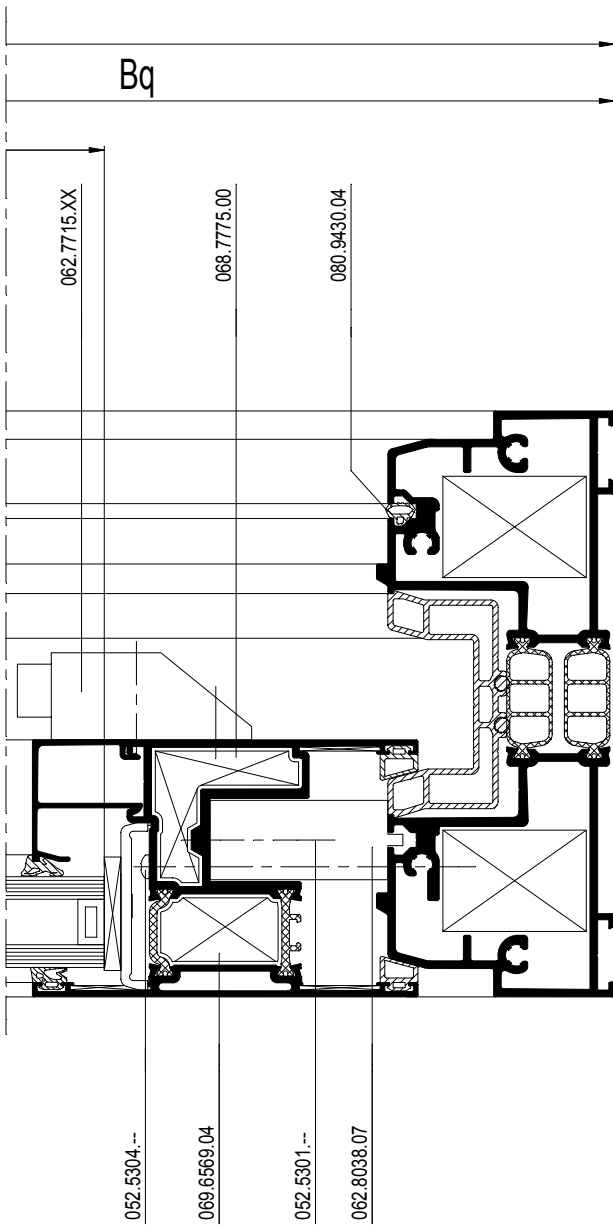

schaal - échelle
 Maßstab - scale
 1/2

D0013911

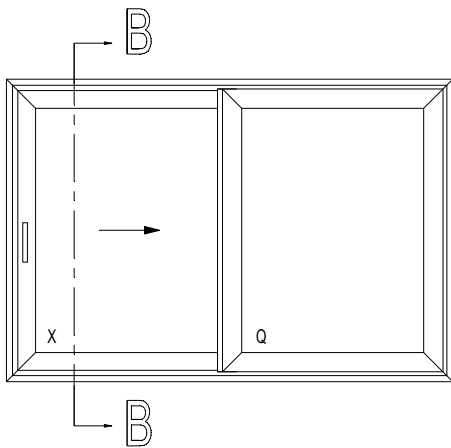

	bx = Bx-173.5
	hx = H-270
	bq = Bq-173.5
	hq = H-270

(*)

			#	$\leftarrow L_m \rightarrow$	
006.1300.XX 006.1301.04			2	B	34.C....
			2	H	
011.4631.--			1	B-106	34.C....
006.1340.XX			2	Bx-7.5	34.C....
			2	Bq-7.5	
			4	H-104	
006.1342.XX			2	H-104	34.C....
006.1341.04			2	H-104	34.C....
006.1343.00			1	H-162	34.C....
0U2.0202.XX.			1	280MM	34.C....
			1	(062.8425.ZC) OF-OU-OR-ODER H-214	
				(062.8426.ZC)	
030.3614.XX			2	Bx-161.5	34.C....
			2	Bq-161.5	
			4	H-308	
006.0360.XX			1	Bx-98.3	34.C....
			1	Bq-98.3	
			1	H-75.6	

		#	
068.7555.00		8	34.G....
068.7775.00		8	34.G....
069.6569.04		8	34.G....
060.8723.--		24	34.G....
062.7894.04		2	34.G....
052.5317.--		4	34.G....
071.6554.04		4	34.G....
062.7927.04		min. 8	34.G....
062.8425.ZC		1	34.G....
062.8426.ZC		1	34.G....
052.5313.--		2	34.G....
062.8434.--		1	34.G....
052.5318.--		3	34.G....
062.7718.04		1	34.G....
062.8428.XX		1	34.G....
062.8429.XX		1	34.G....
061.7038.--		1	34.G....
062.7715.XX		1	34.G....
050.5051.--		1	34.G....
062.7834.--		2	34.G....
052.5372.--		4	34.G....
062.8038.07		6	34.G....
052.5301.--		6	34.G....
052.5304.--		6	34.G....
062.8025.04		1	34.G....
053.5403.--		4	34.G....
052.5310.--		2xH (3/m)	34.G....
052.5317.--		H (3/m)	34.G....
052.5317.--		2	34.G....
069.8722.04		16	34.G....
062.6857.04		1	34.G....
069.6830.04		min. 2	34.G....
080.9424.04		4xH	34.G....
080.9104.SY		(2xB)+(4xH)	34.G....
080.9114.SY		(2xB)+(4xH)	34.G....
080.9381.04		(4xB)+(4xH)	34.G....
081.9241.07		(5xB)+(3xH)	34.G....
080.9430.04		1xH	34.G....

(*) Afhankelijk van de hoogte
Dépend de l'hauteur
Dependent of the height
Von der Höhe abhängig

VLEUGELGEWICHT POIDS DU VANTAIL WEIGHT OF THE VENT FLÜGELGEWICHT	MAX. 250KG
---	------------

B - B

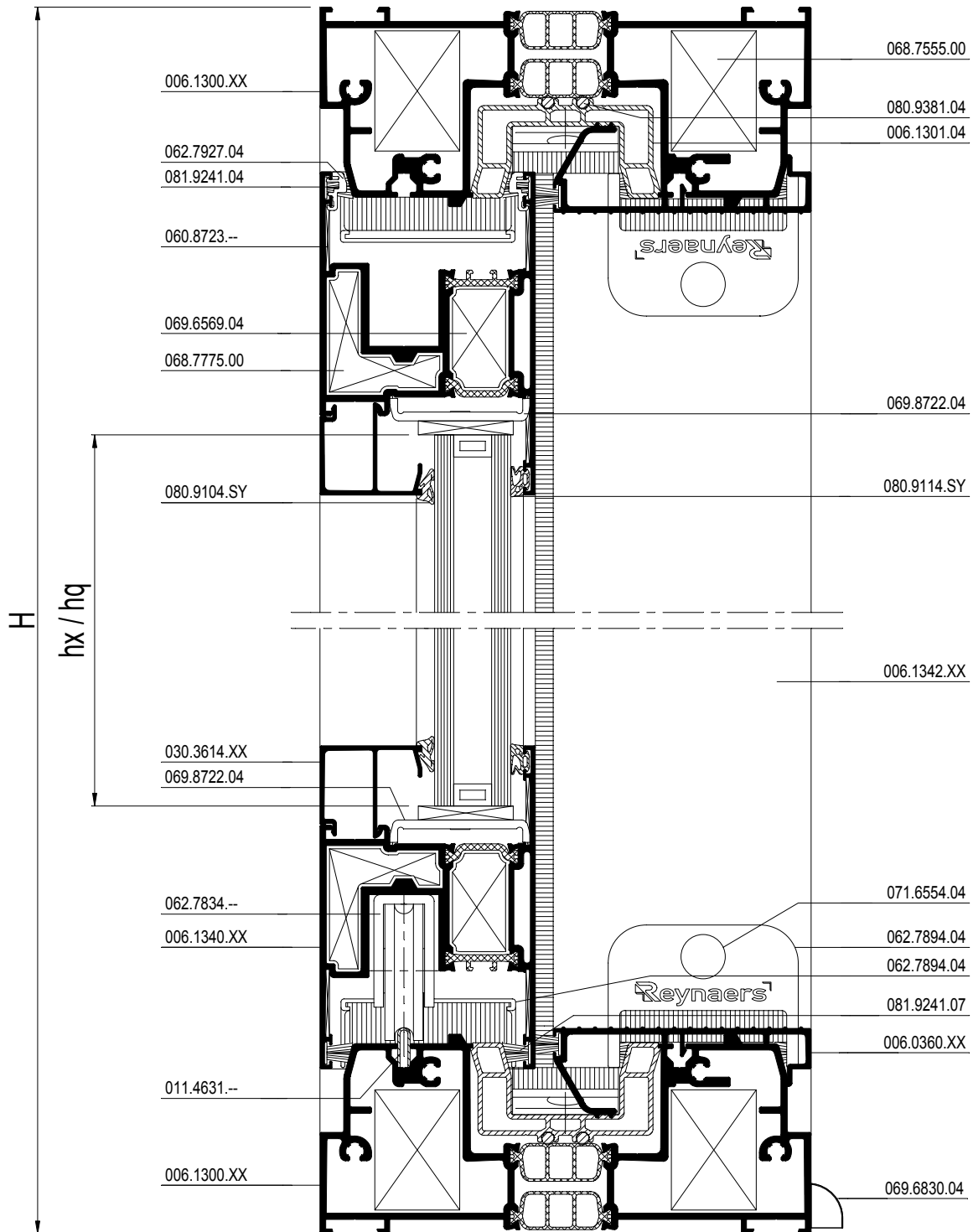

schaal - échelle
 Maßstab - scale
 1/2

D0013912

VARIANT HI
 VARIANTE HI
 VARIANT HI
 VARIANTE HI

VLEUGELGEWICHT POIDS DU VANTAIL WEIGHT OF THE VENT FLÜGELGEWICHT	MAX. 250KG
---	------------

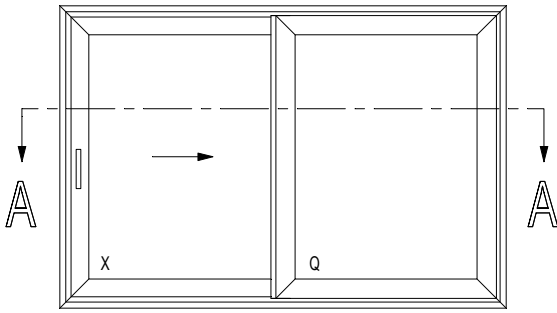

A - A

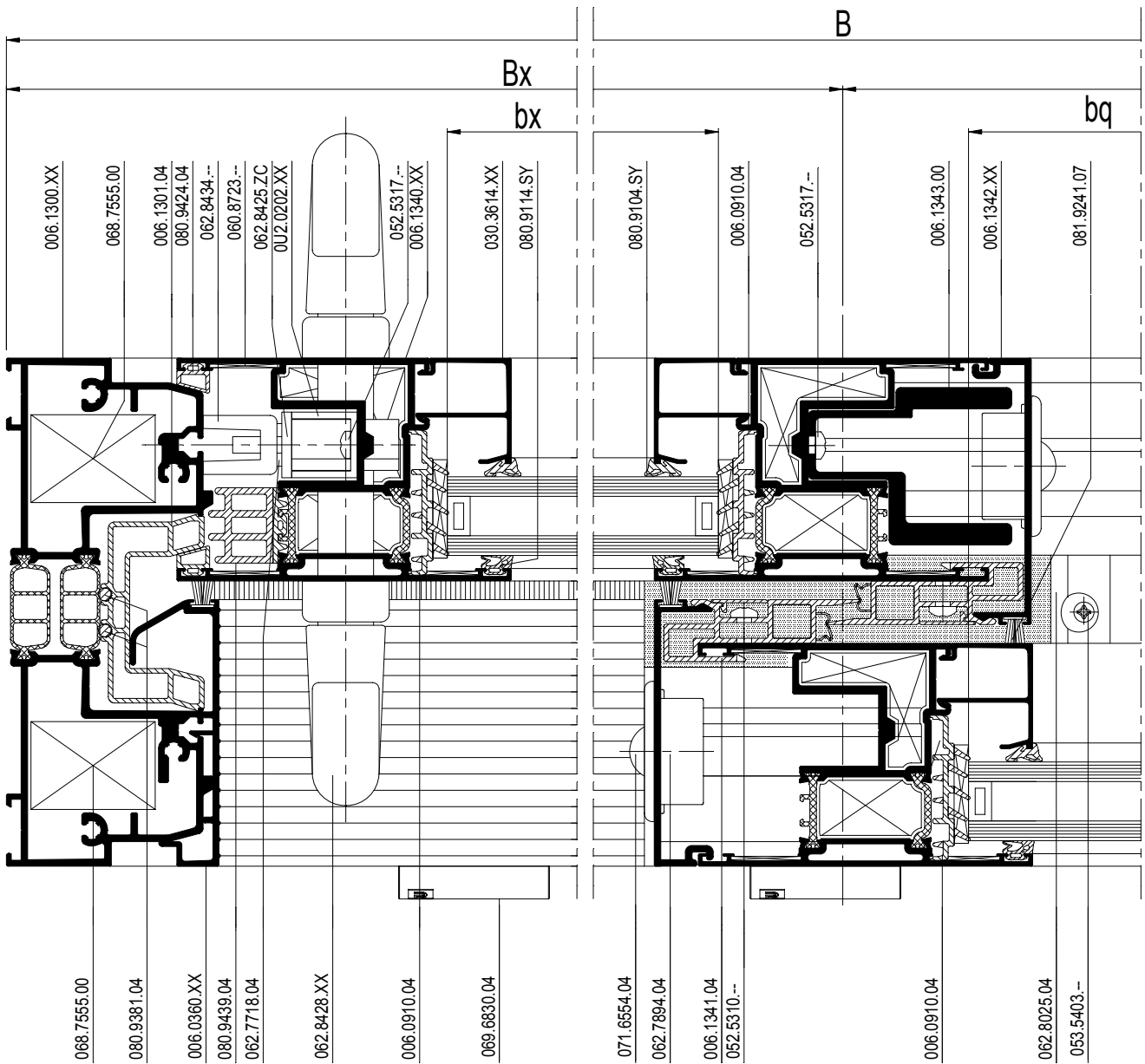

schaal - échelle
 Maßstab - scale
 1/2

D0073972

CP 155

2-RAIL XQ VARIANT HI
 2-RAIL XQ VARIANTE HI
 2-RAIL XQ VARIANT HI
 2-RAIL XQ VARIANTE HI



		or		or	097.0437.00
	---		---		

		or	
	095.A700.00		095.B300.00
	095.A730.00		095.B323.00

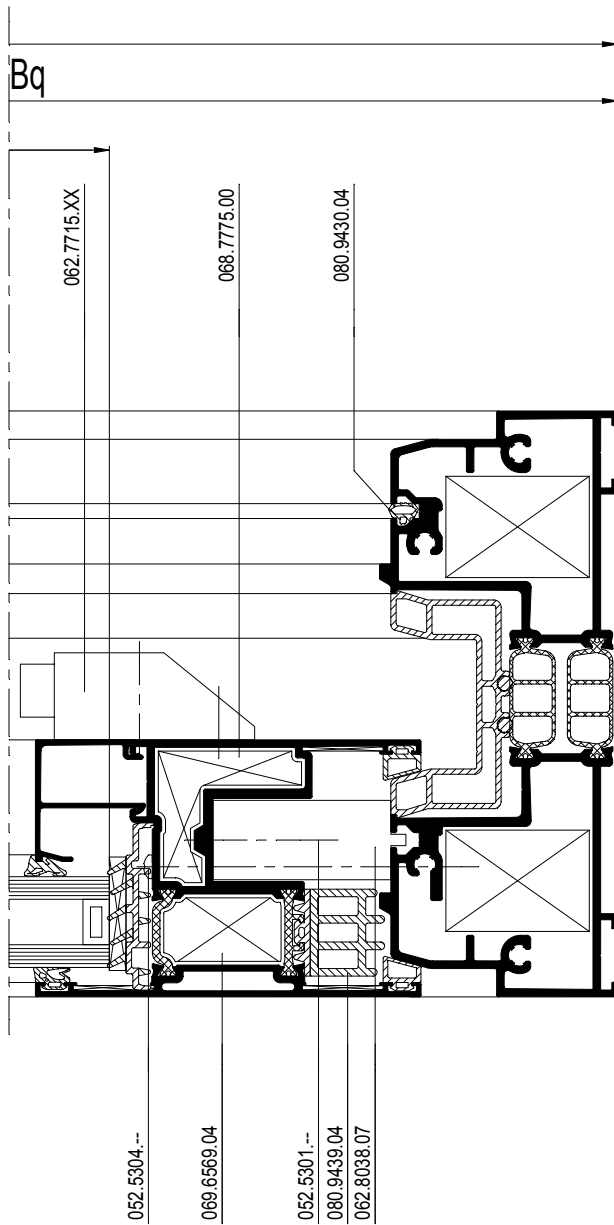

schaal - échelle
 Maßstab - scale
 1/2

D0073972

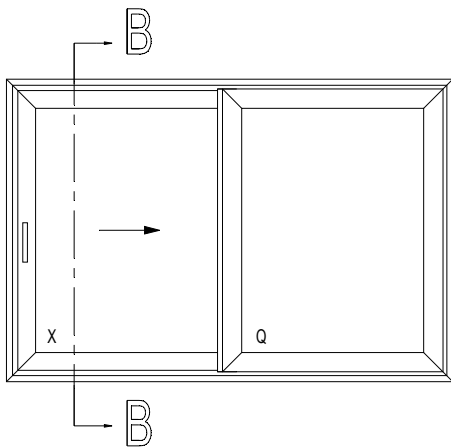

VARIANT HI
 VARIANTE HI
 VARIANT HI
 VARIANTE HI

	bx = Bx-173.5
	hx = H-270
	bq = Bq-173.5
	hq = H-270

			#	$\leftarrow L_m \rightarrow$	
006.1300.XX 006.1301.04			2	B	34.C....
			2	H	
011.4631.--			1	B-106	34.C....
006.1340.XX			2	Bx-7.5	34.C....
			2	Bq-7.5	
			4	H-104	
006.1342.XX			2	H-104	34.C....
006.1341.04			2	H-104	34.C....
006.1343.00			1	H-162	34.C....
0U2.0202.XX.			1	280MM	34.C....
				(062.8425.ZC) OF-OU-OR-ODER	
			1	H-214 (062.8426.ZC)	
030.3614.XX			2	Bx-161.5	34.C....
			2	Bq-161.5	
			4	H-308	
006.0360.XX			1	Bx-98.3	34.C....
			1	Bq-98.3	
			1	H-75.6	
006.0910.XX			2	Bx-161.5	34.C....
			2	Bq-161.5	34.C....
			4	H-264	34.C....

(*)

		#	
068.7555.00		8	34.G....
068.7775.00		8	34.G....
069.6569.04		8	34.G....
060.8723.--		24	34.G....
062.7894.04		2	34.G....
052.5317.--		4	34.G....
071.6554.04		4	34.G....
062.7927.04		min. 8	34.G....
062.8425.ZC OF-OU-OR-ODER		1	34.G....
062.8426.ZC		1	34.G....
052.5313.--		2	34.G....
062.8434.--		1	34.G....
052.5318.--		3	34.G....
062.7718.04		1	34.G....
062.8428.XX		1	34.G....
062.8429.XX		1	34.G....
061.7038.--		1	34.G....
062.7715.XX		1	34.G....
050.5051.--		1	34.G....
062.7834.--		2	34.G....
052.5372.--		4	34.G....
062.8038.07		6	34.G....
052.5301.--		6	34.G....
052.5304.--		6	34.G....
062.8025.04		1	34.G....
053.5403.--		4	34.G....
052.5310.--		2xH (3/m)	34.G....
052.5317.--		H (3/m)	34.G....
052.5317.--		2	34.G....
069.8722.04		16	34.G....
062.6857.04		1	34.G....
069.6830.04		min. 2	34.G....
080.9424.04		4xH	34.G....
080.9104.SY		(2xB)+(4xH)	34.G....
080.9114.SY		(2xB)+(4xH)	34.G....
080.9381.04		(4xB)+(4xH)	34.G....
081.9241.07		(5xB)+(3xH)	34.G....
080.9430.04		1xH	34.G....
080.9439.04		(1xB)+(2xH)	34.G....

(*) Afhankelijk van de hoogte
 Dépend de l'hauteur
 Dependent of the height
 Von der Höhe abhängig

VLEUGELGEWICHT POIDS DU VANTAIL WEIGHT OF THE VENT FLÜGELGEWICHT	MAX. 250KG
---	------------

B - B

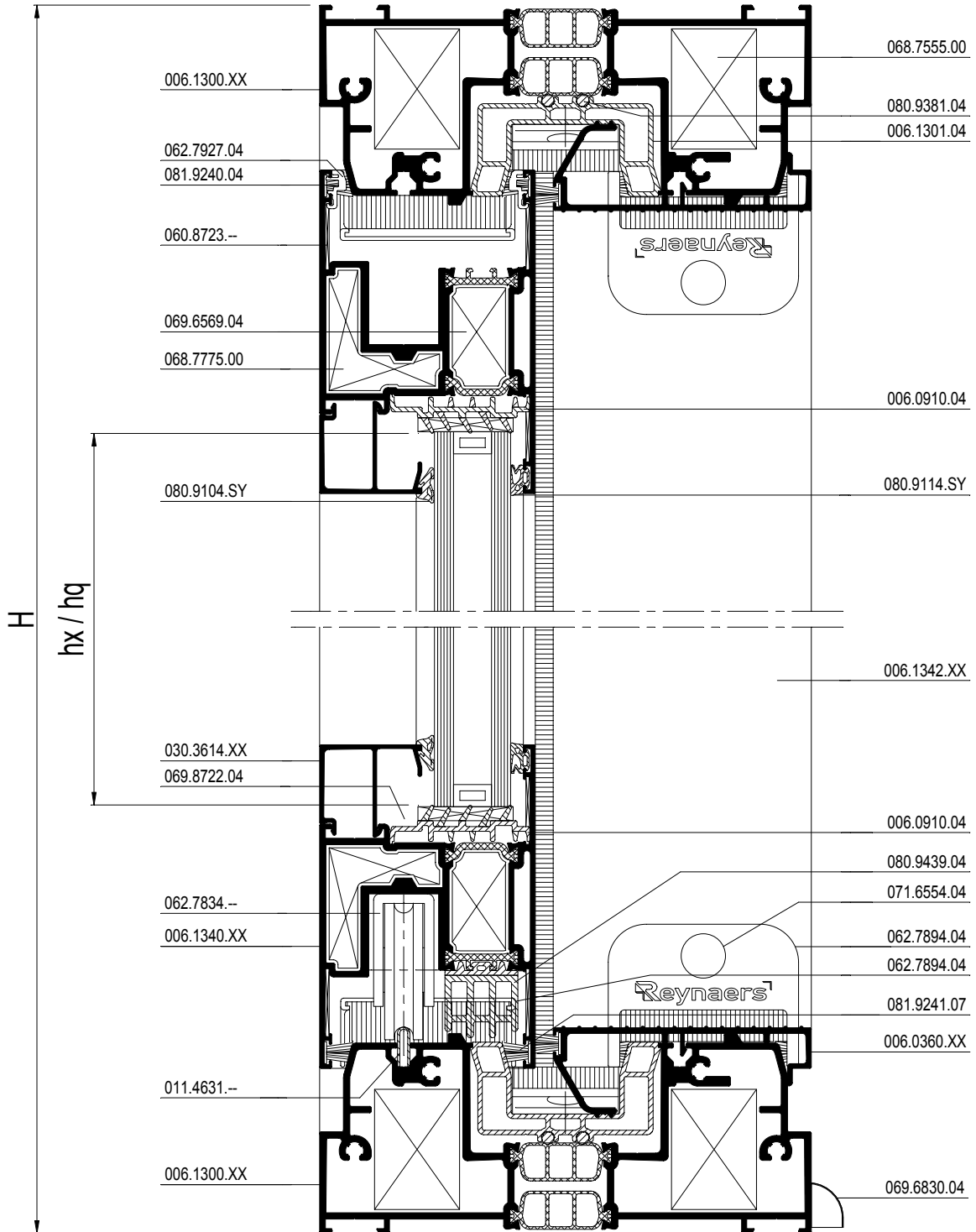

schaal - échelle
 Maßstab - scale
 1/2

D0073973

VLEUGELGEWICHT POIDS DU VANTAIL WEIGHT OF THE VENT FLÜGELGEWICHT	MAX. 250KG
---	------------

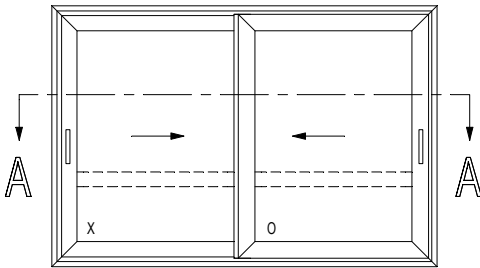

A - A

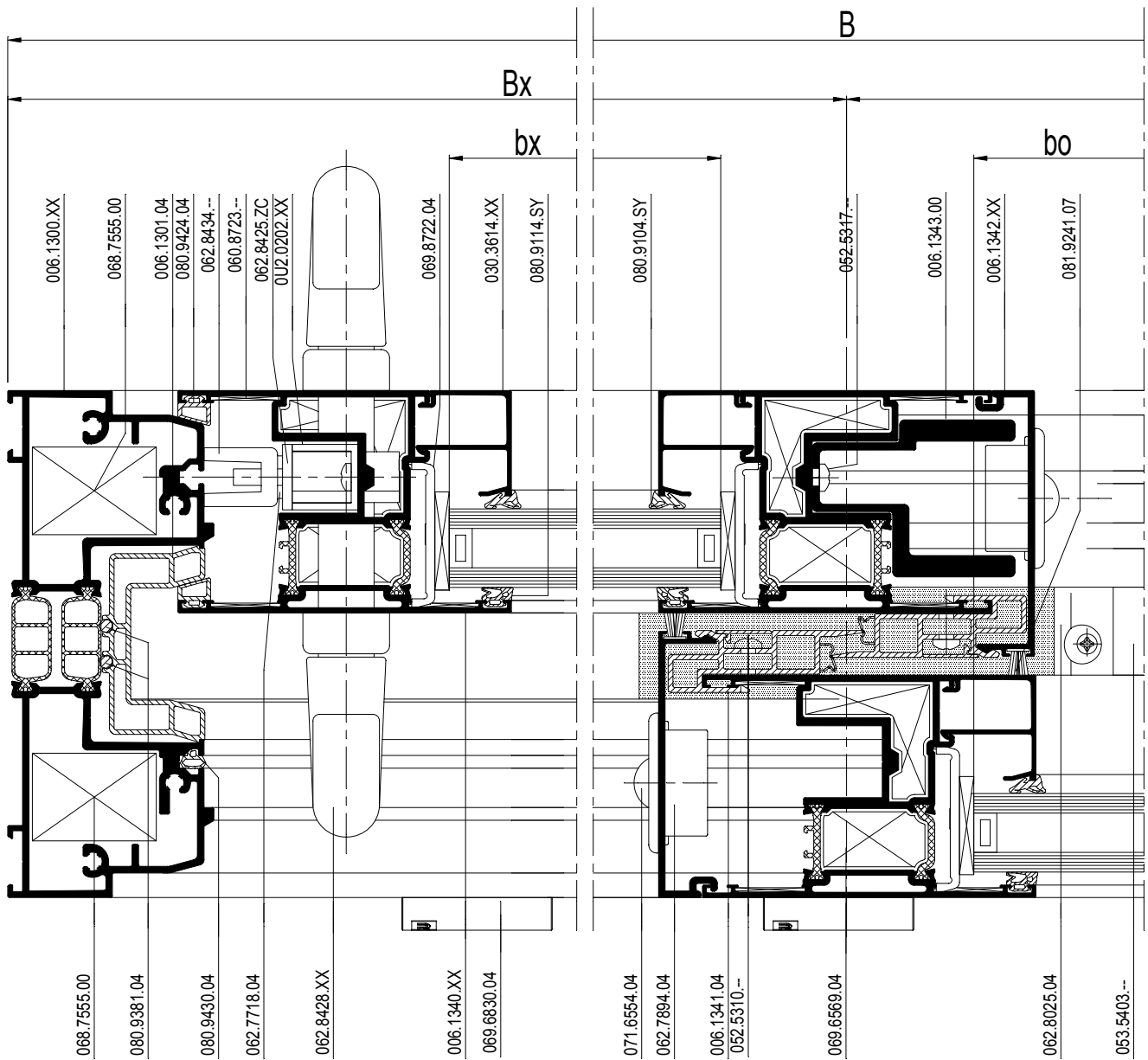

schaal - échelle
 Maßstab - scale
 1/2

D0013913

CP 155

2-RAIL XO
 2-RAIL XO
 2-RAIL XO
 2-RAIL XO



		or		or	
	---	or	---	or	097.0437.00

		or	
	095.A700.00	or	095.B300.00
	095.A730.00		095.B323.00

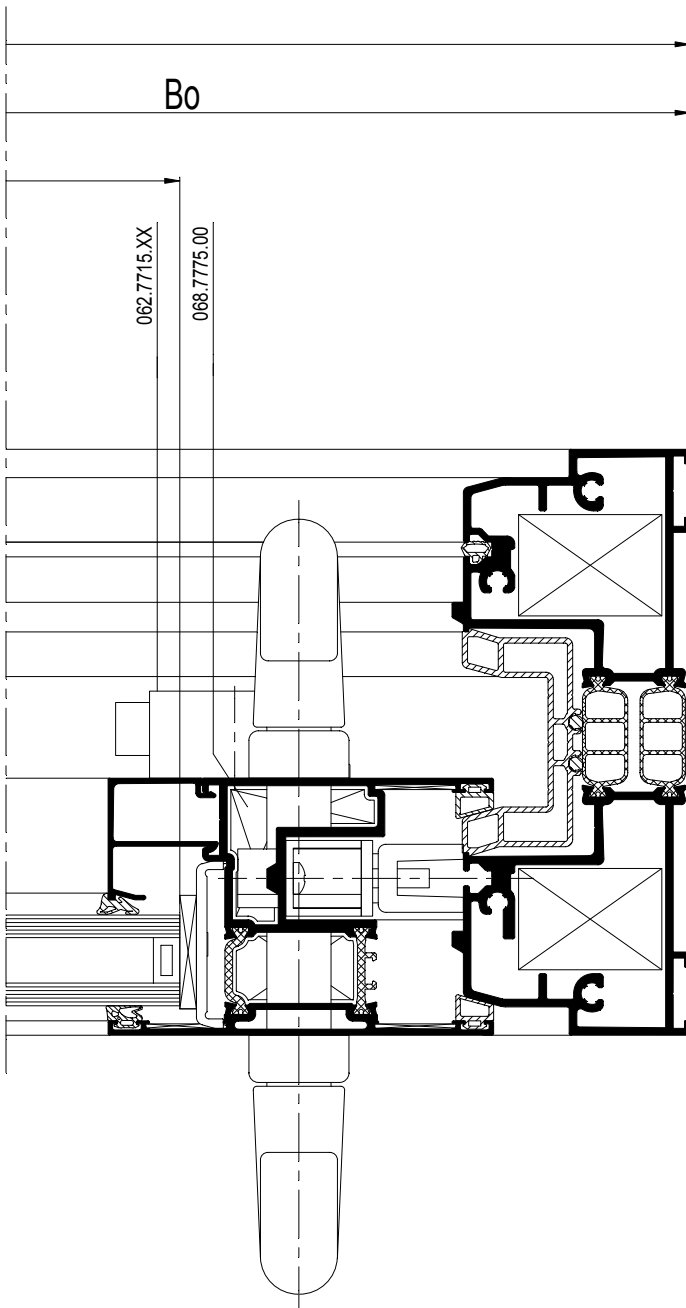

schaal - échelle
 Maßstab - scale
 1/2

D0013913

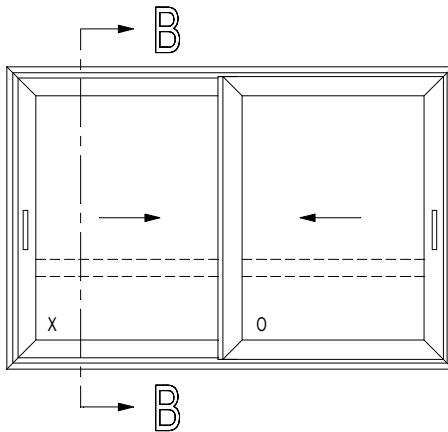

met dwarsstijl
avec traverse
with transom
mit Sprossenprofil

	bx = Bx-173.5
	hx = H-270
	bo = Bo-173.5
	ho = H-270
	t1 = T1-167
	t2 = T2-167

			#	$\leftarrow L_m \rightarrow$	
006.1300.XX 006.1301.04			2	B	34.C....
011.4631.--			2	H	34.C....
006.1340.XX			2	Bx-7.5	34.C....
			2	Bq-7.5	
			4	H-104	
006.1342.XX			2	H-104	34.C....
006.1341.04			2	H-104	34.C....
006.1343.00			1	H-162	34.C....
0U2.0202.XX.			2	280MM	34.C....
			2	(062.8425.ZC) OF-OU-OR-ODER H-214	
			2	(062.8426.ZC)	
030.3614.XX			2	Bx-161.5	34.C....
			2	Bq-161.5	
			4	H-308	

met dwarsstijl
avec traverse
with transom
mit Sprossenprofil

008.3114.XX			1	Bx-161.5	34.C....
			1	Bo-161.5	

VLEUGELGEWICHT POIDS DU VANTAIL WEIGHT OF THE VENT FLÜGELGEWICHT	MAX. 250KG
---	------------

(*)

		#	
068.7555.00		8	34.G....
068.7775.00		8	34.G....
069.6569.04		8	34.G....
060.8723.--		24	34.G....
062.7894.04		2	34.G....
052.5317.--		4	34.G....
071.6554.04		4	34.G....
062.7927.04		min. 8	34.G....
062.8425.ZC OF-OU-OR-ODER		2	34.G....
062.8426.ZC		2	34.G....
052.5313.--		4	34.G....
062.8434.--		2	34.G....
052.5318.--		6	34.G....
062.7718.04		2	34.G....
062.8428.XX		2	34.G....
062.8429.XX		2	34.G....
061.7038.--		2	34.G....
062.7715.XX		1	34.G....
050.5051.--		1	34.G....
062.7834.--		4	34.G....
052.5372.--		8	34.G....
062.8025.04		1	34.G....
053.5403.--		4	34.G....
052.5310.--		2xH (3/m)	34.G....
052.5317.--		H (3/m)	34.G....
052.5317.--		4	34.G....
069.8722.04		16	34.G....
062.6857.04		1	34.G....
069.6830.04		min. 2	34.G....
080.9424.04		4xH	34.G....
080.9104.SY		(2xB)+(4xH)	34.G....
080.9114.SY		(2xB)+(4xH)	34.G....
080.9381.04		(4xB)+(4xH)	34.G....
081.9241.07		(5xB)+(3xH)	34.G....
080.9430.04		1xH	34.G....

met dwarsstijl
avec traverse
with transom
mit Sprossenprofil

(*) Afhankelijk van de hoogte
Dépend de l'hauteur
Dependent of the height
Von der Höhe abhängig

068.8732.00		4	34.G....
050.5153.--		8	34.G....
069.8722.04		16	34.G....
080.9104.SY		2xB	34.G....
080.9114.SY		2xB	34.G....

B - B

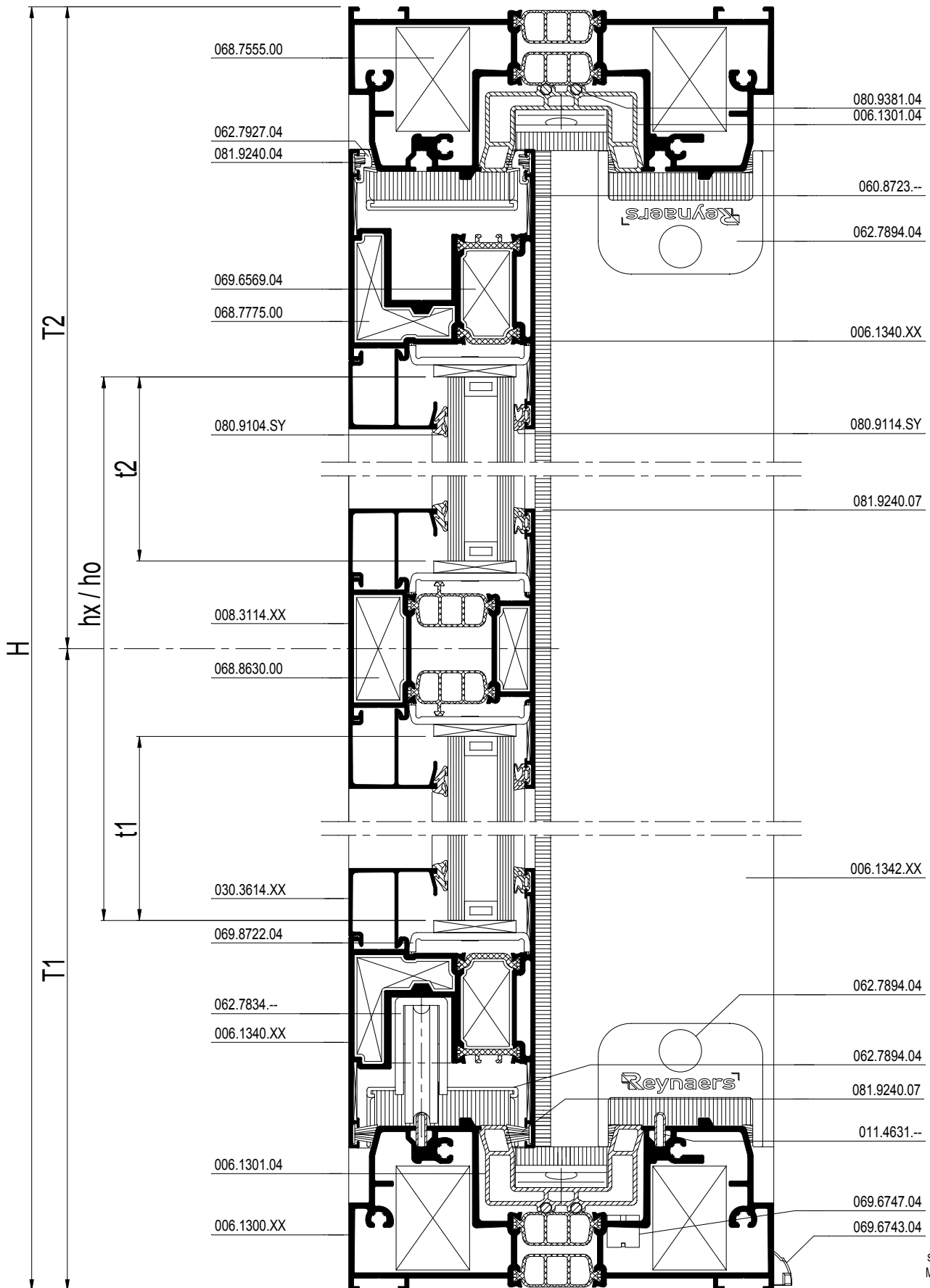

schaal - échelle
 Maßstab - scale
 1/2

D0013914

VLEUGELGEWICHT POIDS DU VANTAIL WEIGHT OF THE VENT FLÜGELGEWICHT	MAX. 250KG
---	------------

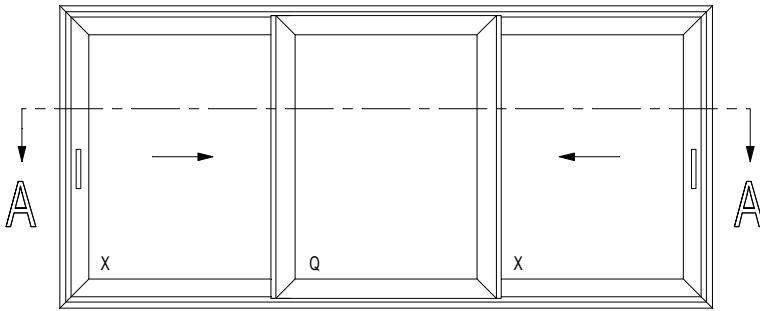

A - A

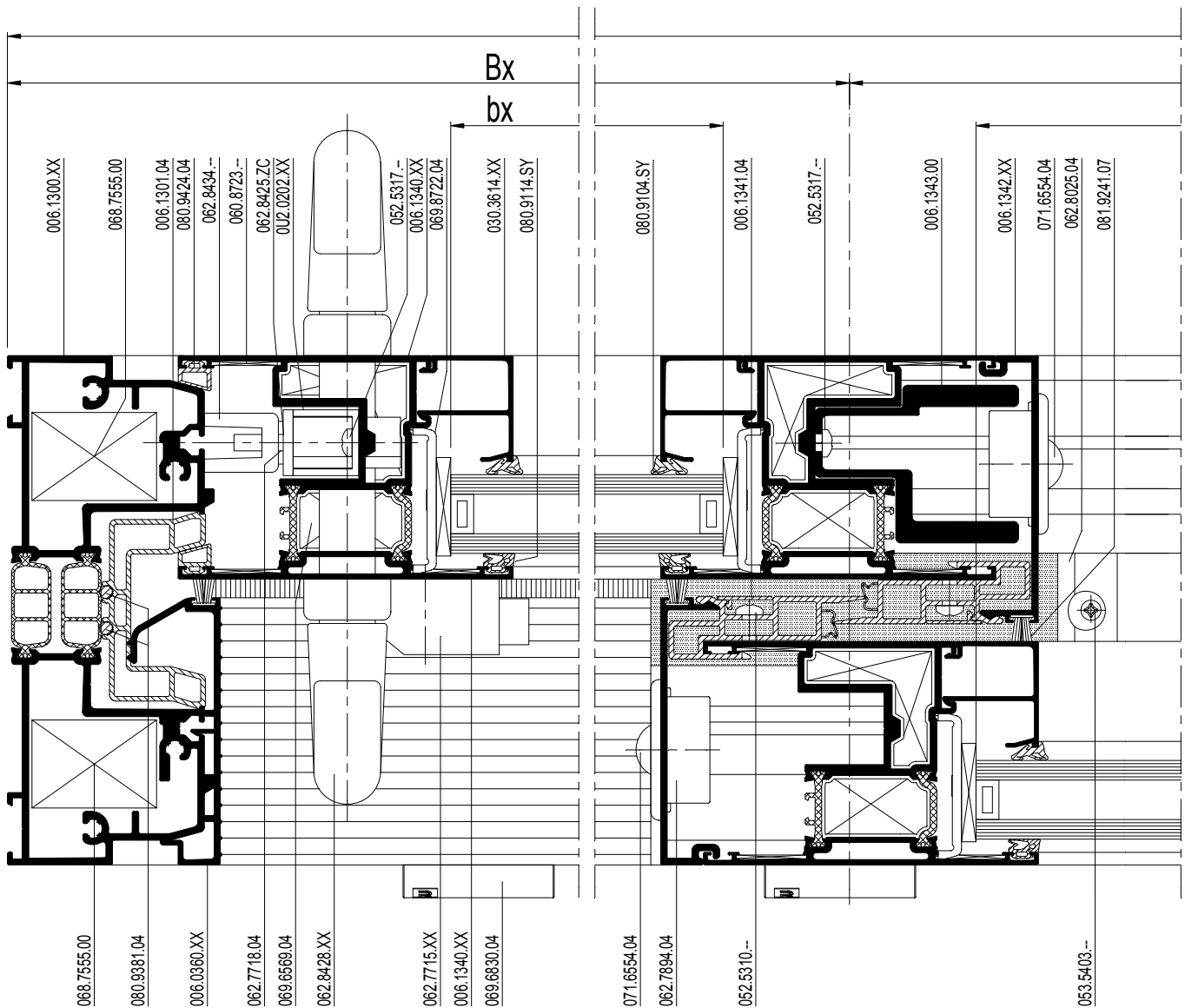

schaal - échelle
 Maßstab - scale
 1/2

D0013915

CP 155

2-RAIL XQX
 2-RAIL XQX
 2-RAIL XQX
 2-RAIL XQX



		or		or	
	---		---		097.0437.00
	---		---		---

		or	
	095.A700.00		095.B300.00
	095.A730.00		095.B323.00

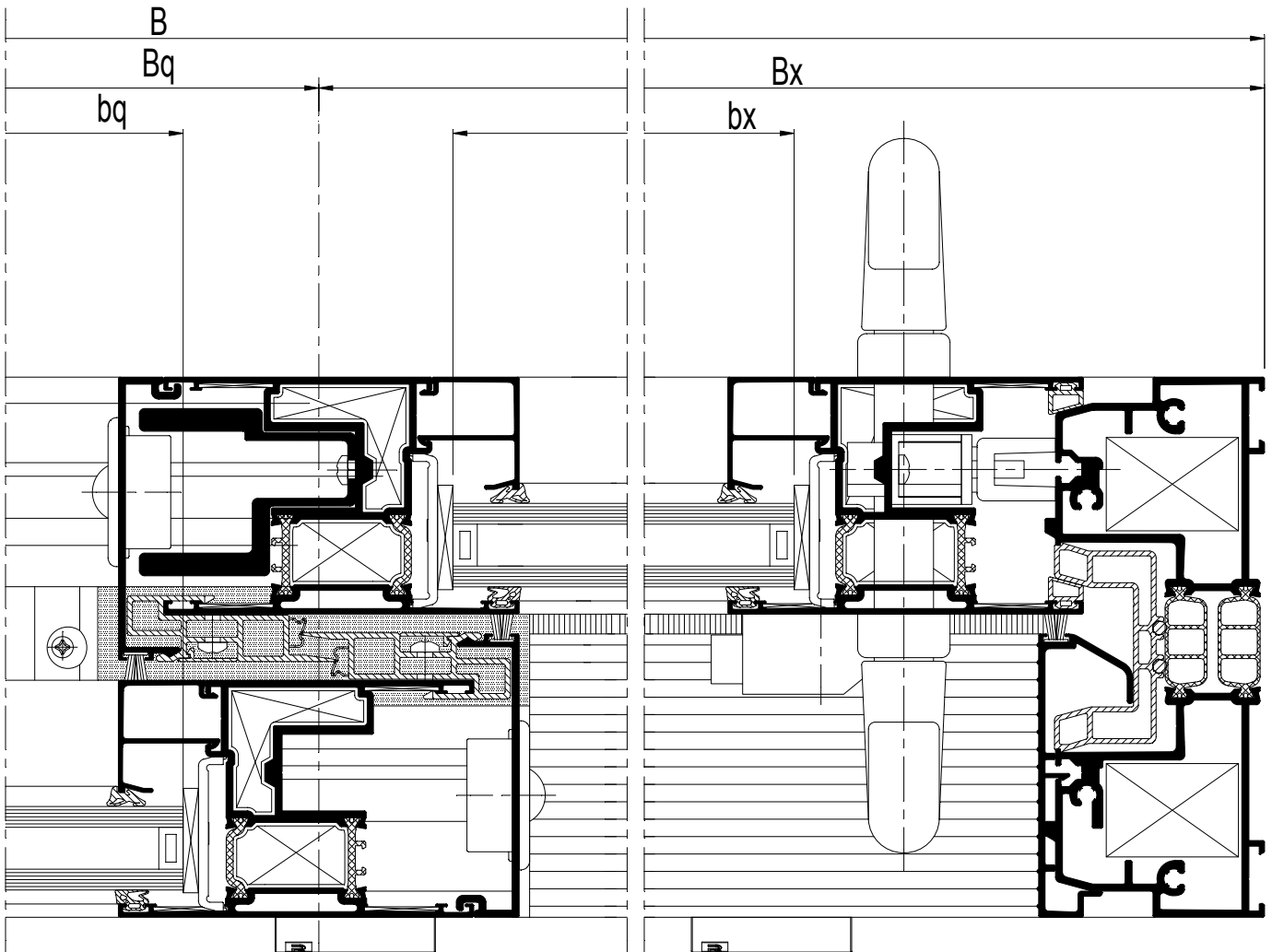

schaal - échelle
 Maßstab - scale
 1/2

D0013915

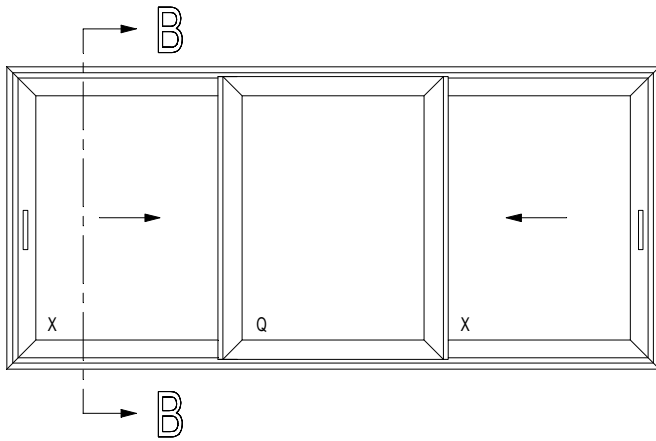

			#	L_m	
006.1300.XX			2	B	34.C....
006.1301.04			2	H	
011.4631.--			1	B-106	34.C....
006.1340.XX			4	Bx-7.5	34.C....
			2	Bq+89	
			6	H-104	
006.1342.XX			4	H-104	34.C....
006.1341.04			4	H-104	34.C....
006.1343.00			2	H-162	34.C....
0U2.0202.XX.			2	280MM	34.C....
				(062.8425.ZC)	
			2	H-214	
				(062.8426.ZC)	
030.3614.XX			4	Bx-161.5	34.C....
			2	Bq-65	
			6	H-308	
006.0360.XX			2	Bx-98.3	34.C....
			2	Bq-98.3	
			2	H-75.6	

bx = Bx-173.5
hx = H-270
bq = Bq-77
ho = H-270

VLEUGELGEWICHT POIDS DU VANTAIL WEIGHT OF THE VENT FLÜGELGEWICHT	MAX. 250KG
---	------------

(*)

		#	
068.7555.00		8	34.G....
068.7775.00		12	34.G....
069.6569.04		12	34.G....
060.8723.--		36	34.G....
062.7894.04		4	34.G....
052.5317.--		8	34.G....
071.6554.04		8	34.G....
062.7927.04		min. 12	34.G....
062.8425.ZC		2	34.G....
OF-OU-OR-ODER			
062.8426.ZC		2	34.G....
052.5313.--		4	34.G....
062.8434.--		2	34.G....
052.5318.--		6	34.G....
062.7718.04		2	34.G....
062.8428.XX		2	34.G....
062.8429.XX		2	34.G....
061.7038.--		2	34.G....
062.7715.XX		2	34.G....
050.5051.--		2	34.G....
062.7834.--		4	34.G....
052.5372.--		8	34.G....
062.8038.07		3	34.G....
052.5301.--		3	34.G....
052.5304.--		3	34.G....
062.8025.04		2	34.G....
053.5403.--		8	34.G....
052.5310.--		4xH (3/m)	34.G....
052.5317.--		2xH (3/m)	34.G....
052.5317.--		4	34.G....
069.8722.04		24	34.G....
062.6857.04		2	34.G....
069.6830.04		min. 2	34.G....
080.9424.04		4xH	34.G....
080.9104.SY		34.G....	34.G....
080.9114.SY		(2xB)+(6xH)	34.G....
080.9381.04		(2xB)+(6xH)	34.G....
081.9241.07		(4xB)+(6xH)	34.G....
		+(4xBx)	

(*) Afhankelijk van de hoogte
Dépend de l'hauteur
Dependent of the height
Von der Höhe abhängig

B - B

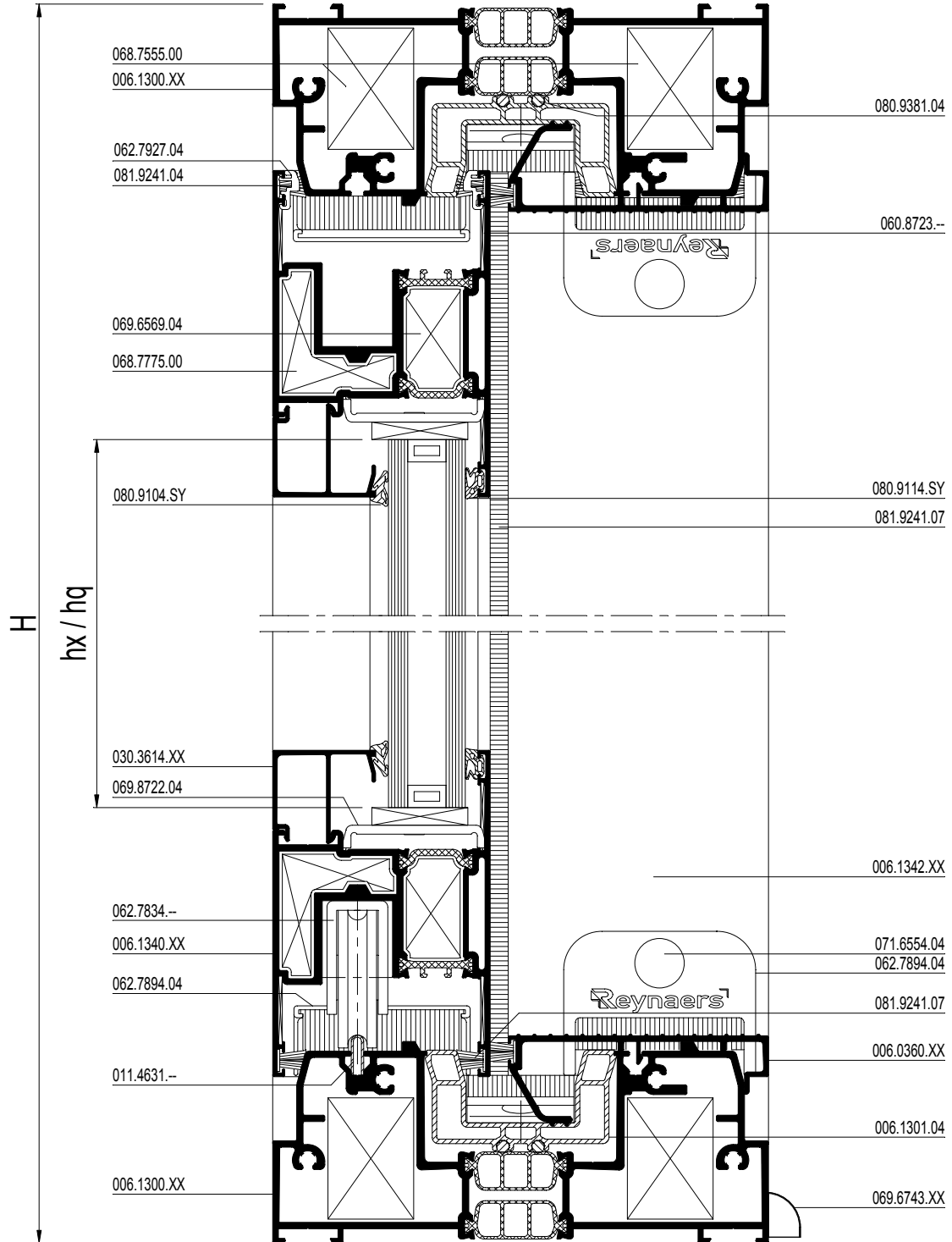

schaal - échelle
 Maßstab - scale
 1/2

D0013916

VLEUGELGEWICHT POIDS DU VANTAIL WEIGHT OF THE VENT FLÜGELGEWICHT	MAX. 250KG
---	------------

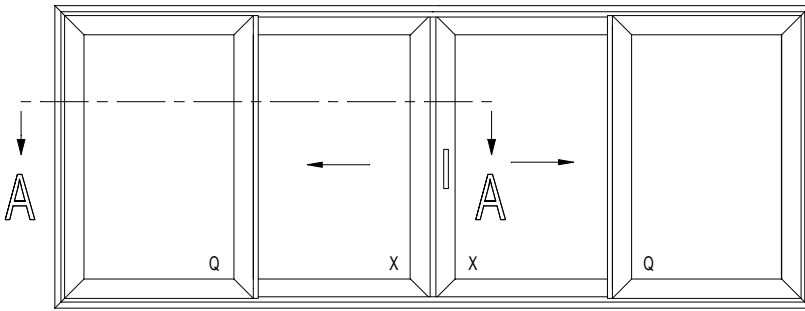

A - A

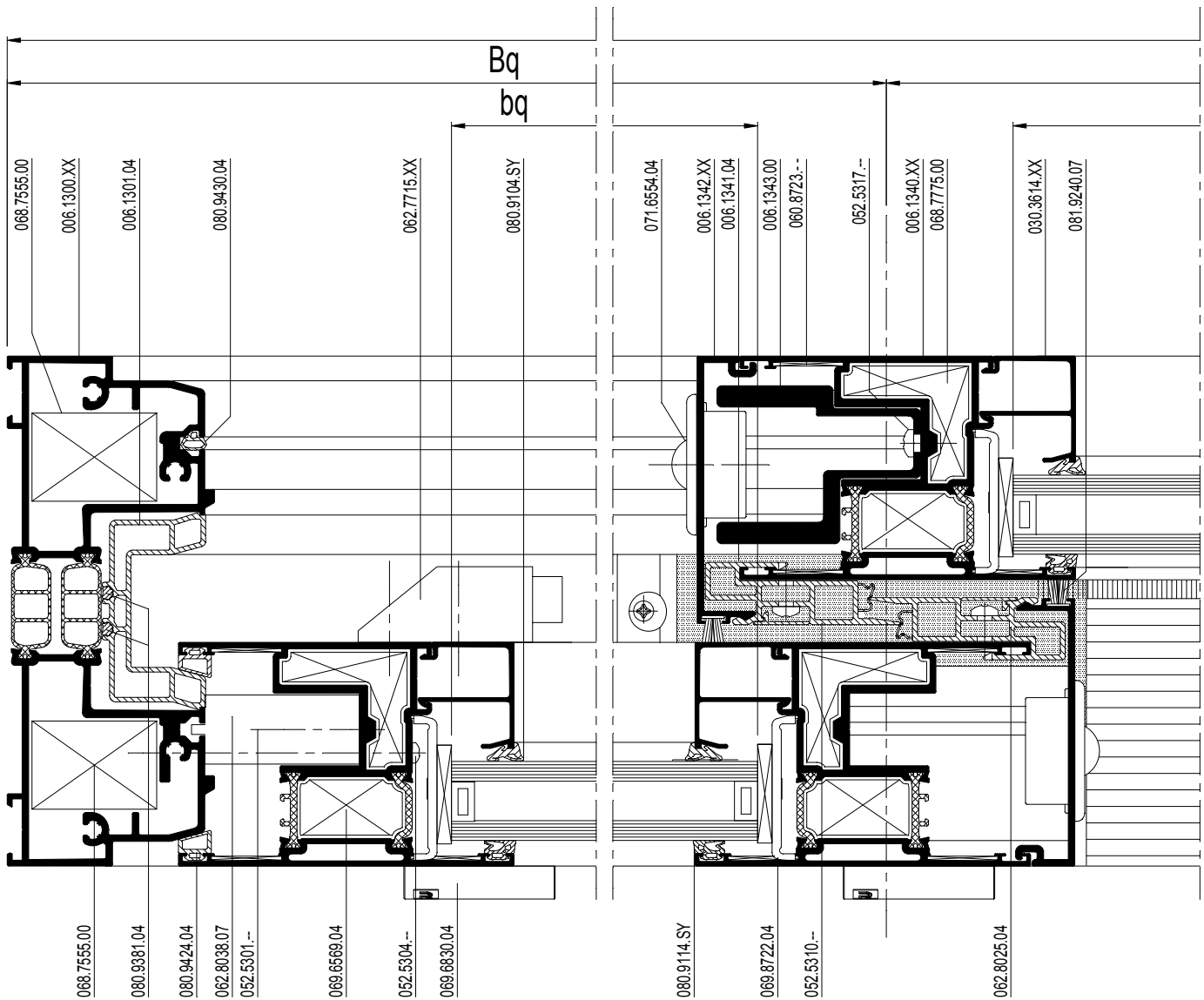

D0013917

CP 155

2-RAIL OXXQ
 2-RAIL OXXQ
 2-RAIL OXXQ
 2-RAIL OXXQ



		or		or	
	---		---		097.0437.00

		or	
	095.A700.00 095.A730.00	or	095.B300.00 095.B323.00

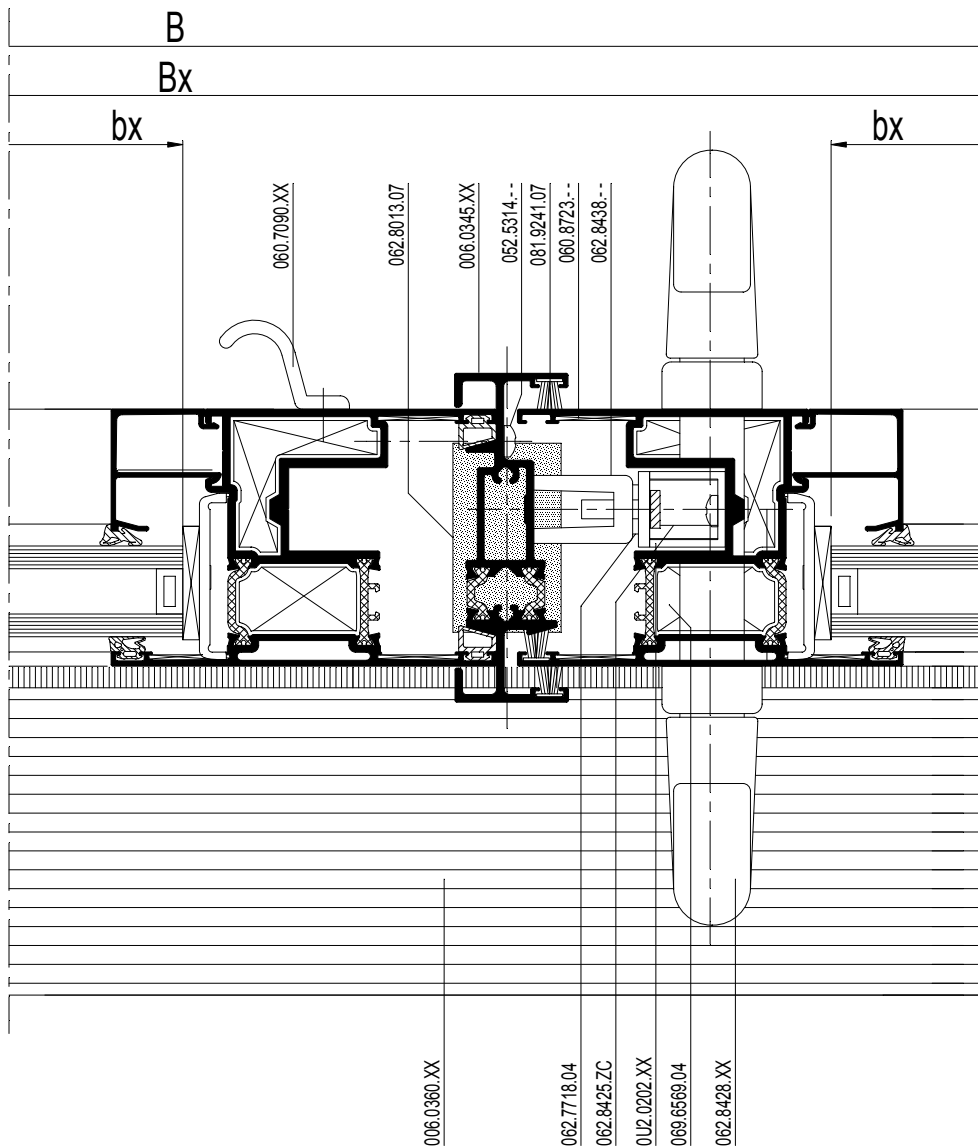

schaal - échelle
 Maßstab - scale
 1/2

D0013917

VLEUGELGEWICHT POIDS DU VANTAIL WEIGHT OF THE VENT FLÜGELGEWICHT	MAX. 250KG
---	------------

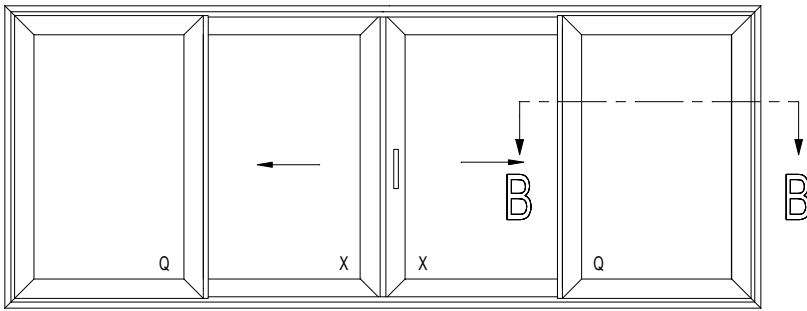



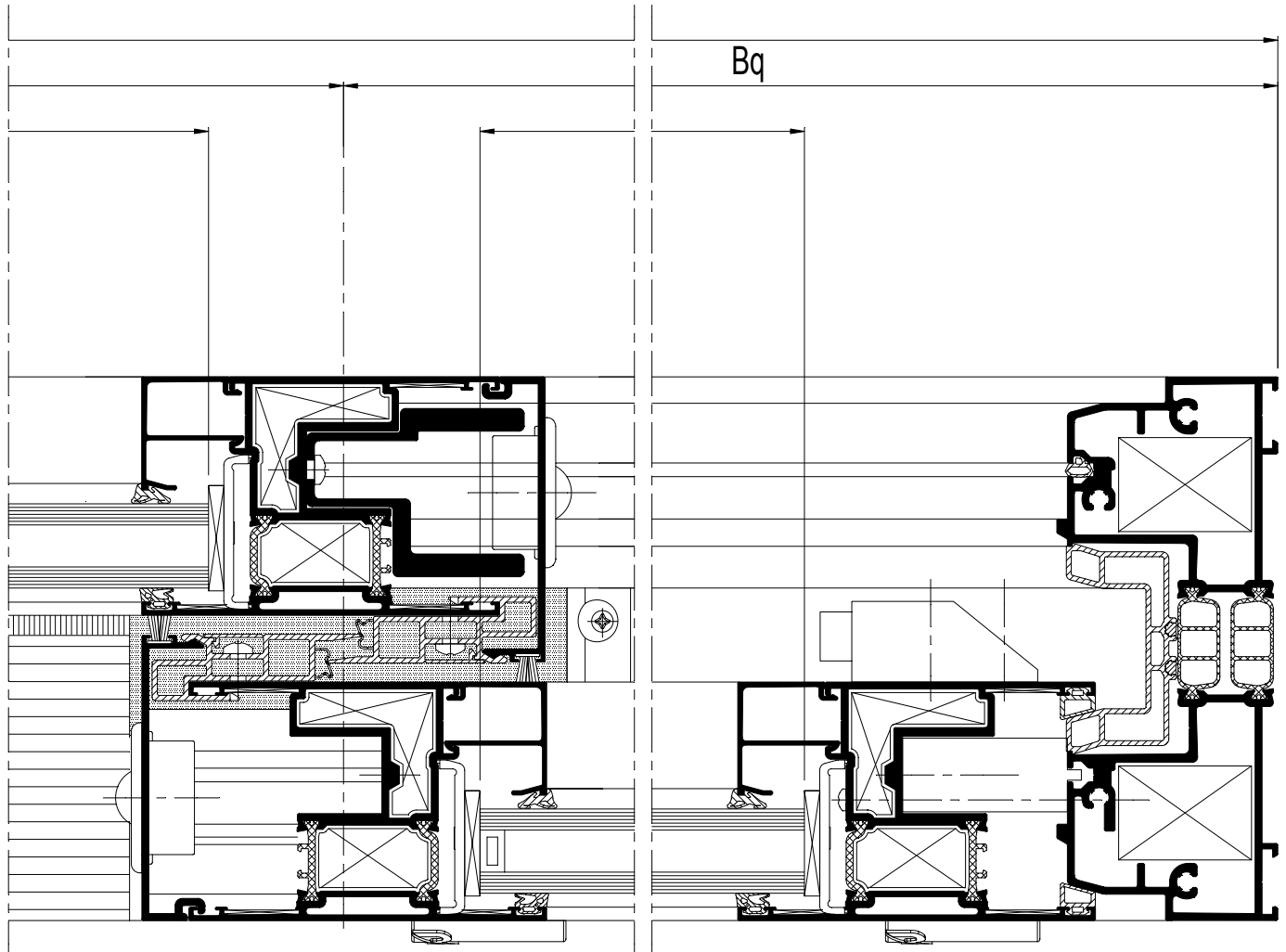



































B - B



schaal - échelle
 Maßstab - scale
 1/2

D0013918

		#	
068.7555.00		8	34.G...
068.7775.00		16	34.G...
069.6569.04		16	34.G...
060.8723.--		48	34.G...
062.7894.04		4	34.G...
052.5317.--		8	34.G...
071.6554.04		8	34.G...
062.7927.04		min.16	34.G...
062.8425.ZC <small>OF-OU-OR-ODER</small>		1	34.G...
(*) 062.8426.ZC		1	34.G...
052.5313.--		2	34.G...
062.8438.--		1	34.G...
052.5318.--		2	34.G...
062.7718.04		1	34.G...
062.8429.XX		1	34.G...
062.8428.XX		1	34.G...
061.7038.--		1	34.G...
060.7090.XX		1	34.G...
052.5312.--		2	34.G...
062.7715.XX		2	34.G...
050.5051.--		2	34.G...
062.7834.--		4	34.G...
052.5372.--		8	34.G...
062.8038.07		12	34.G...
052.5301.--		12	34.G...
052.5304.--		12	34.G...
062.8025.04		2	34.G...
053.5403.--		8	34.G...
062.8013.07		1	34.G...
053.5403.--		4	34.G...
052.5310.--		4xH (3/m)	34.G...
052.5317.--		2xH (3/m)	34.G...
052.5317.--		2	34.G...
052.5314.--		H (3/m)	34.G...
062.6857.04		2	34.G...
069.8722.04		32	34.G...
069.6830.04		min. 2	34.G...
080.9424.04		6xH	34.G...
080.9104.SY		(2xB)+(8xH)	34.G...
080.9114.SY		(2xB)+(8xH)	34.G...
080.9381.04		(4xB)+(4xH)	34.G...
081.9241.07		(4xB)+(7xH) +(2xBx)	34.G...
080.9430.04		2xH	34.G...

(*) Afhankelijk van de hoogte
Dépend de l'hauteur
Dependent of the height
Von der Höhe abhängig

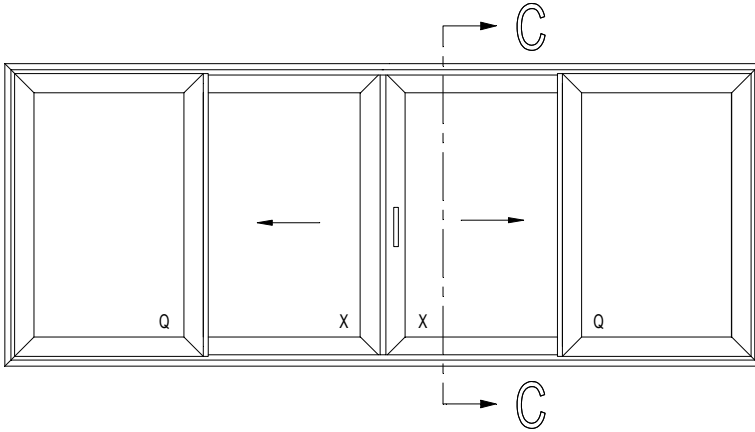

			#	$\leftarrow L_m \rightarrow$	
006.1300.XX			2	B	34.C....
006.1301.04			2	H	
011.4631.--			1	B-106	34.C....
006.1340.XX			4	$(Bx:2)+41.75$	34.C....
			4	Bq-7.5	
			8	H-104	
006.1342.XX			4	H-104	34.C....
006.1341.04			4	H-104	34.C....
006.1343.00			2	H-162	34.C....
0U2.0202.XX.			1	280MM	34.C....
				(062.8425.ZC)	
			1	H-214	
				(062.8426.ZC)	
006.0345.XX			1	H-104	34.C....
030.3614.XX			4	$(Bx:2)-112.2$	34.C....
			4	Bq-161.5	
			8	H-308	
006.0360. XX			2	Bx-121	34.C....

$bx = (Bx:2)-124.25$
$hx = H-270$
$bq = Bq-173.5$
$hq = H-270$

VLEUGELGEWICHT POIDS DU VANTAIL WEIGHT OF THE VENT FLÜGELGEWICHT	MAX. 250KG
---	------------

C - C

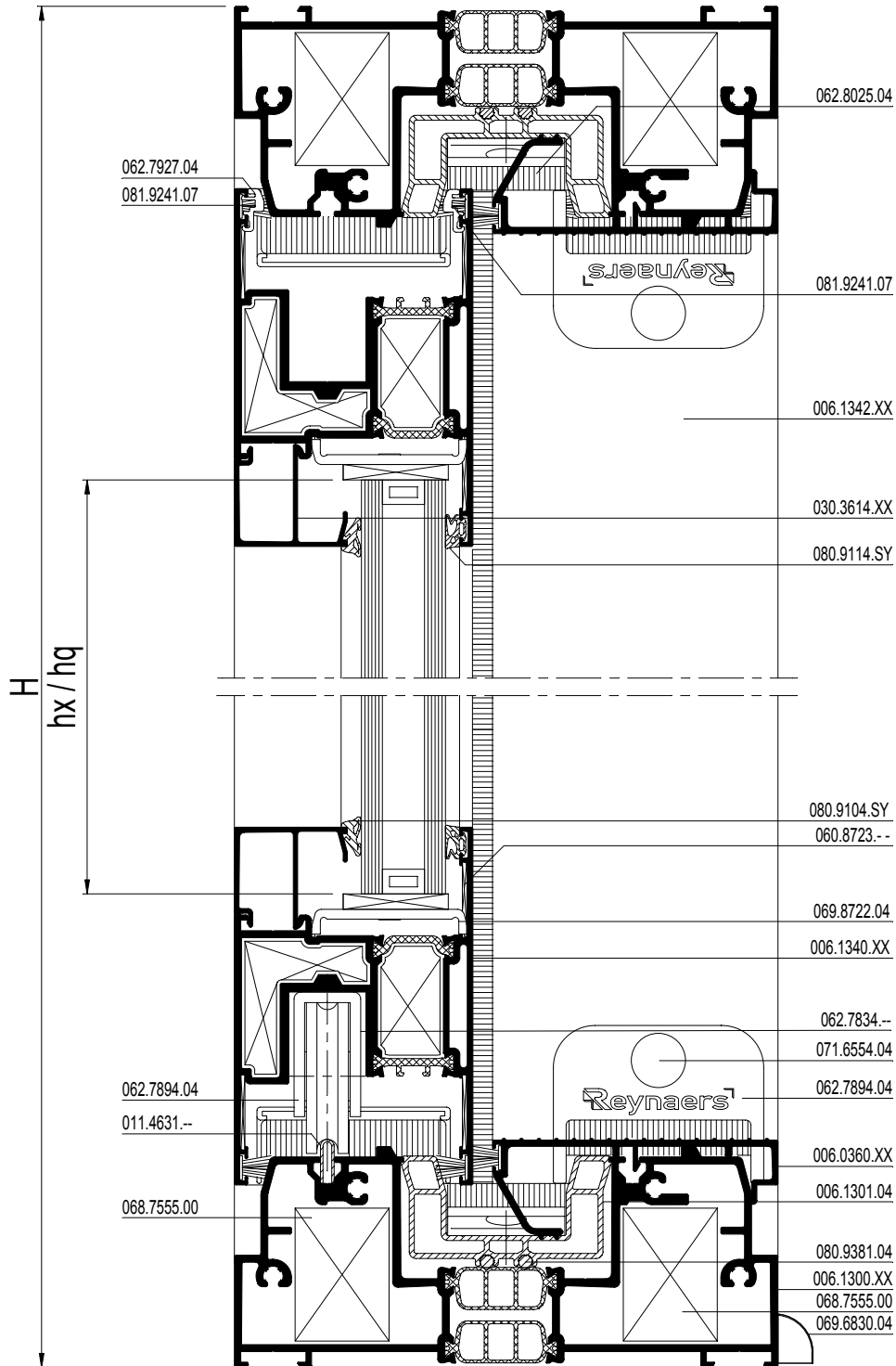

schaal - échelle
 Maßstab - scale
 1/2

D0013919

VLEUGELGEWICHT POIDS DU VANTAIL WEIGHT OF THE VENT FLÜGELGEWICHT	MAX. 250KG
---	------------

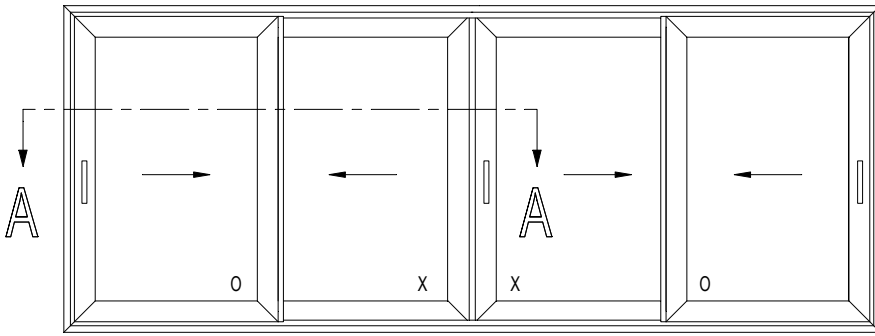

A - A

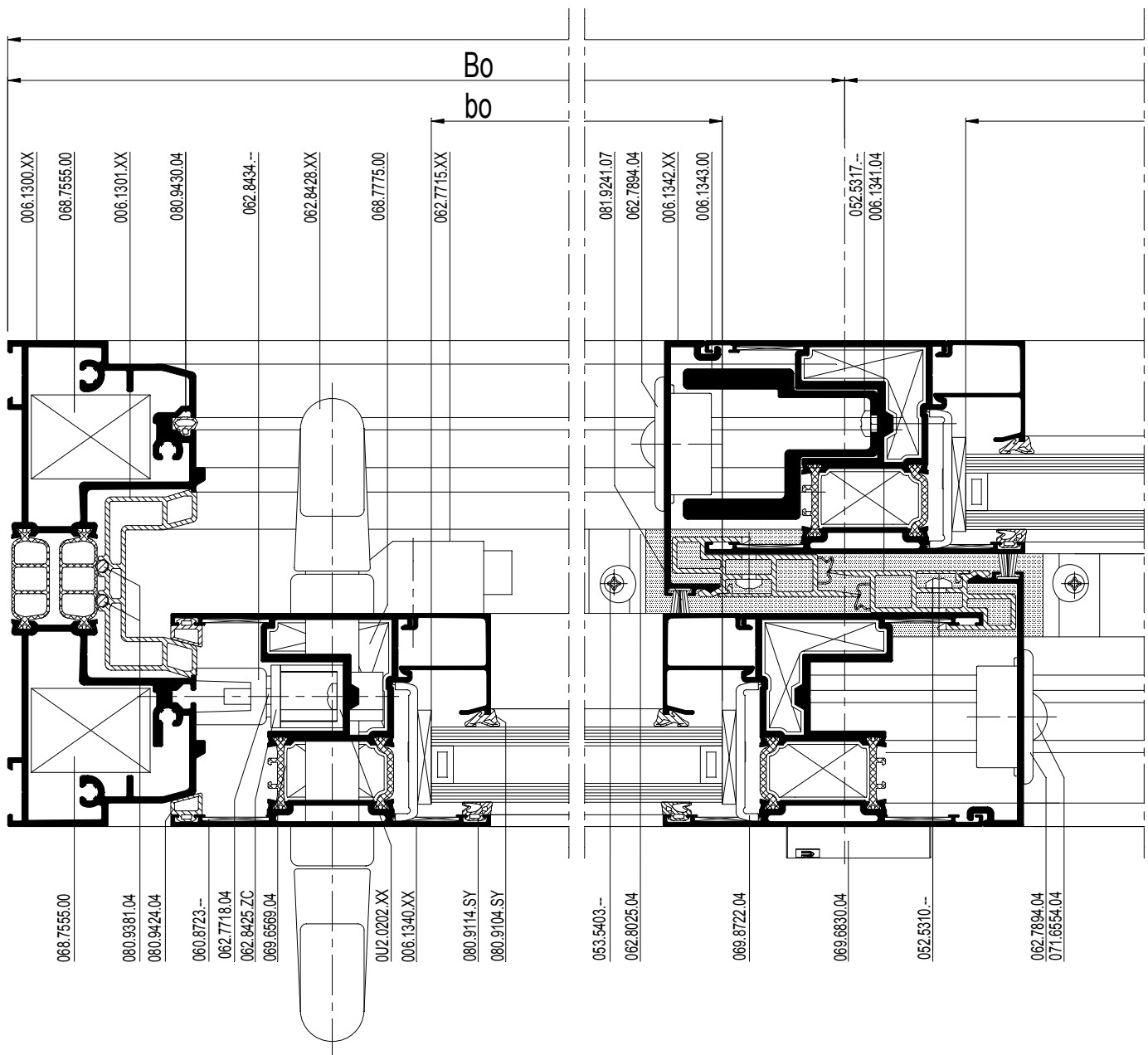

		or		or	097.0437.00
	---		---		

		or	
	095.A700.00	or	095.B300.00
	095.A730.00		095.B323.00

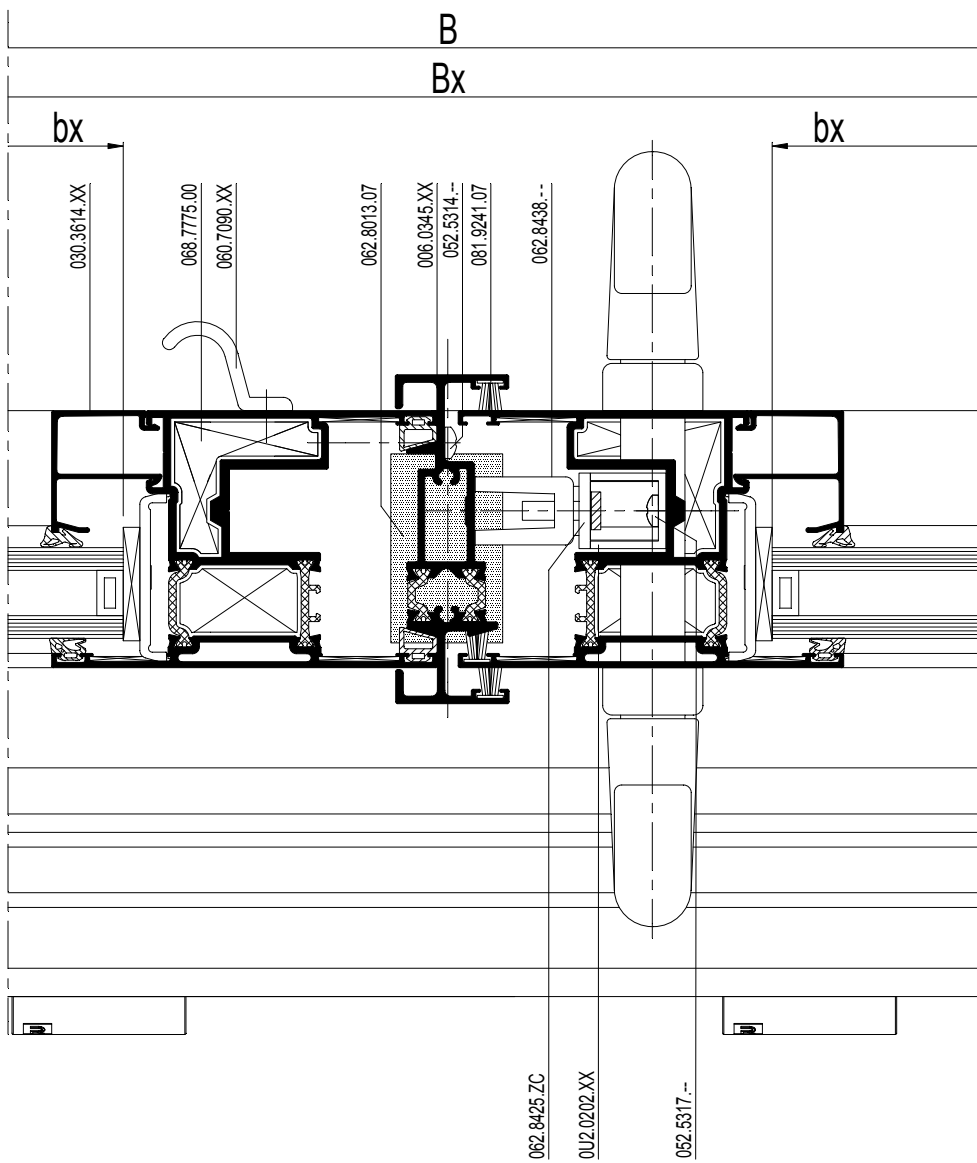

schaal - échelle
 Maßstab - scale
 1/2

D0013920

CP 155







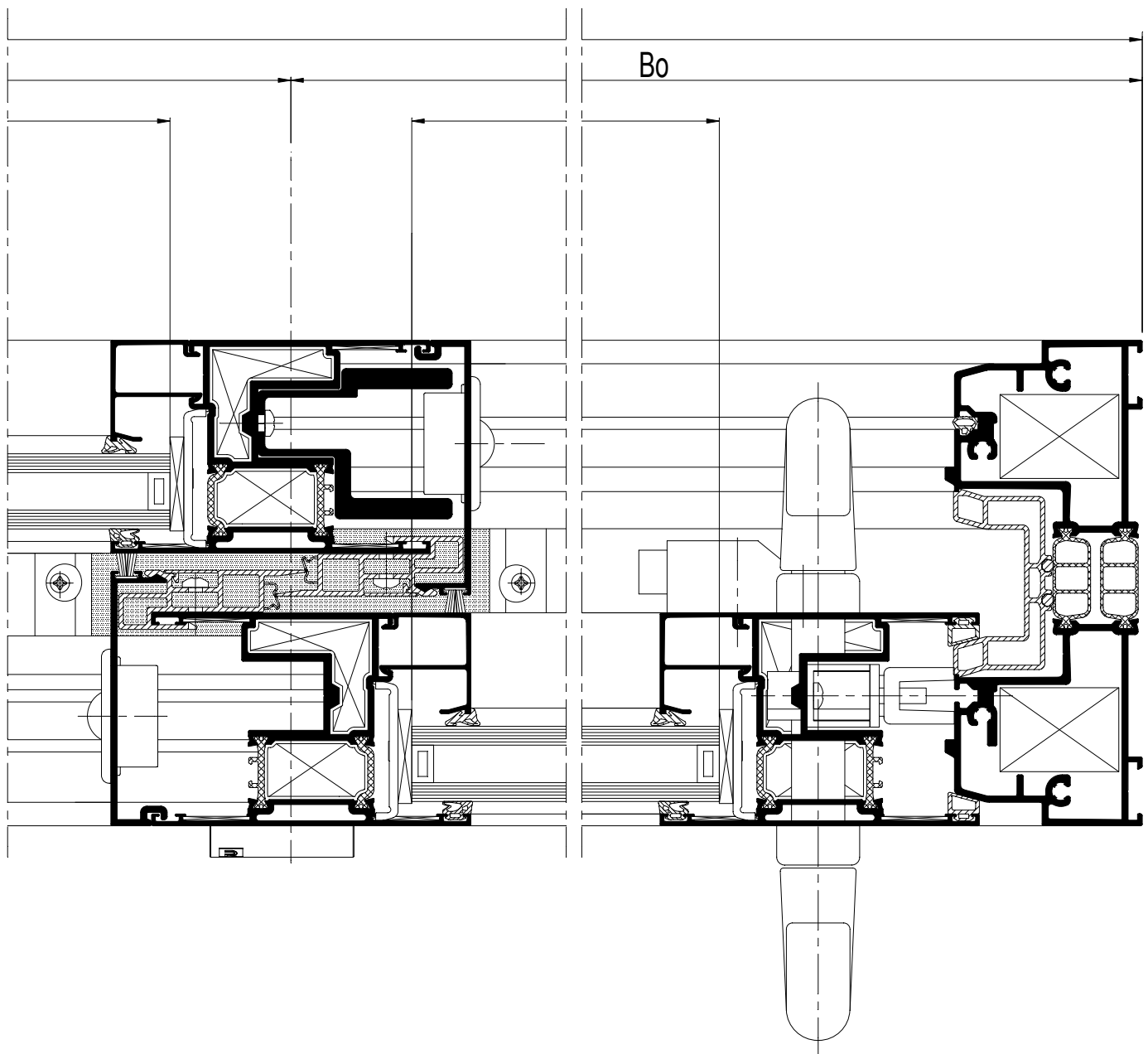
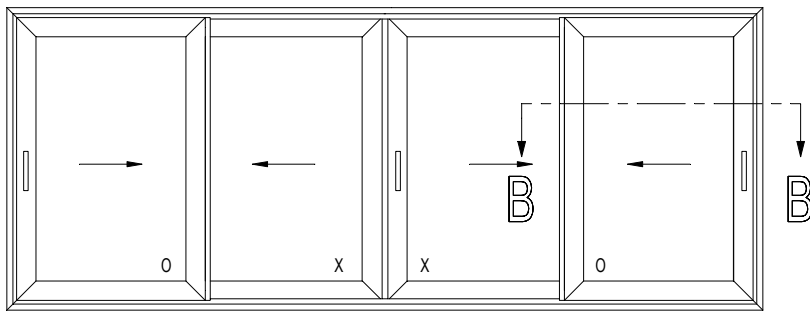





































2-RAIL OXXO
2-RAIL OXXO
2-RAIL OXXO
2-RAIL OXXO



VLEUGELGEWICHT POIDS DU VANTAIL WEIGHT OF THE VENT FLÜGELGEWICHT	MAX. 250KG
---	------------



schaal - échelle
scale - Maßstab
1/2
D0013921

		#	
068.7555.00		8	34.G...
068.7775.00		16	34.G...
069.6569.04		16	34.G...
060.8723.--		48	34.G...
062.7894.04		4	34.G...
052.5317.--		8	34.G...
071.6554.04		8	34.G...
062.7927.04		min.16	34.G...
062.8425.ZC <small>OF-OU-OR-ODER</small>		3	34.G...
062.8426.ZC		3	34.G...
052.5313.--		6	34.G...
062.8434.--		2	34.G...
052.5318.--		6	34.G...
062.8438.--		1	34.G...
052.5318.--		2	34.G...
062.7718.04		3	34.G...
062.8429.--		3	34.G...
062.8428.XX		3	34.G...
061.7038.--		3	34.G...
060.7090.XX		1	34.G...
052.5312.--		2	34.G...
062.7715.XX		2	34.G...
050.5051.--		2	34.G...
062.7834.--		8	34.G...
052.5372.--		16	34.G...
062.8025.04		2	34.G...
053.5403.--		8	34.G...
062.8013.07		1	34.G...
052.5317.--		4	34.G...
052.5310.--		4xH (3/m)	34.G...
052.5317.--		2xH (3/m)	34.G...
052.5317.--		6	34.G...
052.5314.--		H (3/m)	34.G...
069.8722.04		32	34.G...
062.6857.04		1	34.G...
069.6830.04		min. 2	34.G...
080.9424.04		6xH	34.G...
080.9104.SY		(2xB)+(8xH)	34.G...
080.9114.SY		(2xB)+(8xH)	34.G...
080.9381.04		(4xB)+(4xH)	34.G...
081.9241.07		(4xB)+(7xH)	34.G...
080.9430.04		2xH	34.G...

(*)

Afhankelijk van de hoogte
Dépend de l'hauteur
Dependent of the height
Von der Höhe abhängig

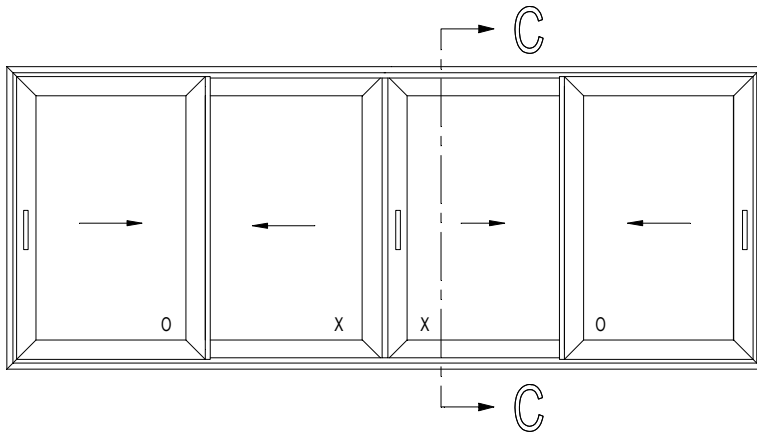

VLEUGELGEWICHT POIDS DU VANTAIL FLÜGELGEWICHT WEIGHT OF THE VENT	MAX. 250KG
---	------------

			#	$\leftarrow L_m \rightarrow$	
006.1300.XX			2	B	34.C....
006.1301.04			2	H	
011.4631.--			2	B-106	34.C....
006.1340.XX			4	$(Bx:2)+41.75$	34.C....
			4	$Bo-7.5$	
			8	H-104	
006.1342.XX			4	H-104	34.C....
006.1341.04			4	H-104	34.C....
006.1343.00			2	H-162	34.C....
0U2.0202.XX.			3	280MM	34.C....
			3	(062.8425.ZC) OF-OU-ODER-OR H-214	
			3	(062.8426.ZC)	
006.0345.XX			1	H-104	34.C....
030.3614.XX			4	$(Bx:2)-112.2$	34.C....
			4	$Bo-161.5$	
			8	H-308	

$bx = (Bx:2)-124.25$
$hx = H-270$
$bo = Bo-173.5$
$ho = H-270$

C - C

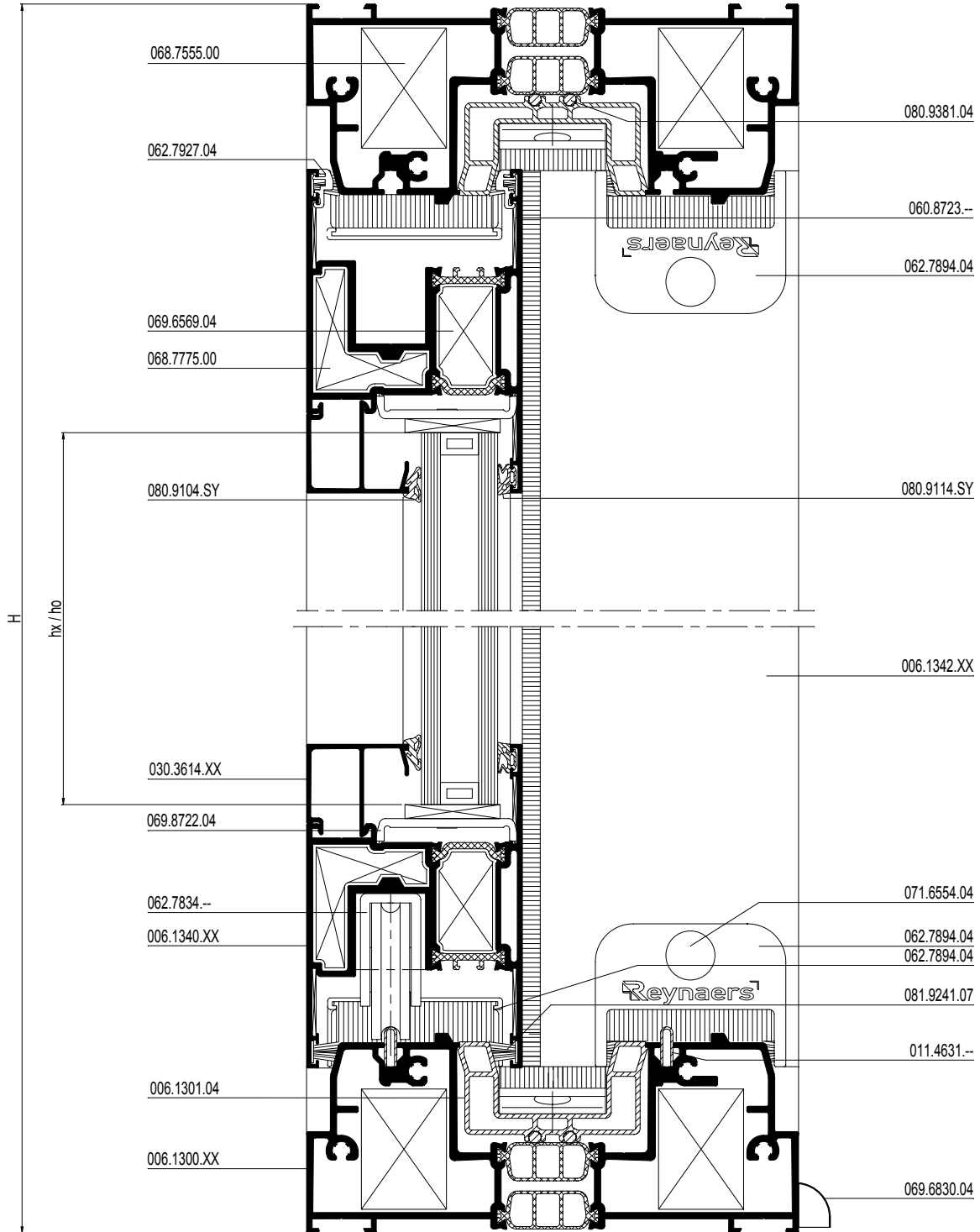

schaal - échelle
 scale - Maßstab
 1/2

D0013922

VLEUGELGEWICHT POIDS DU VANTAIL WEIGHT OF THE VENT FLÜGELGEWICHT	MAX. 250KG
---	------------

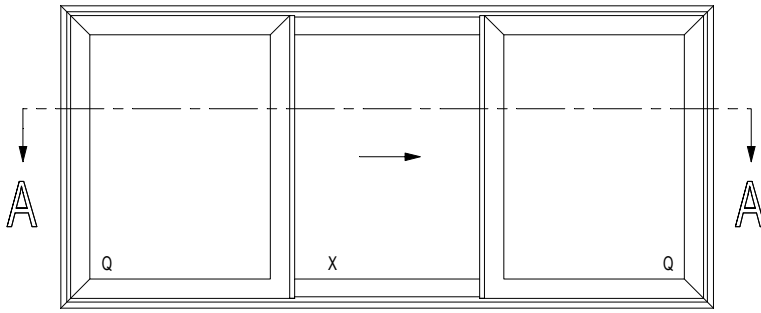

A - A

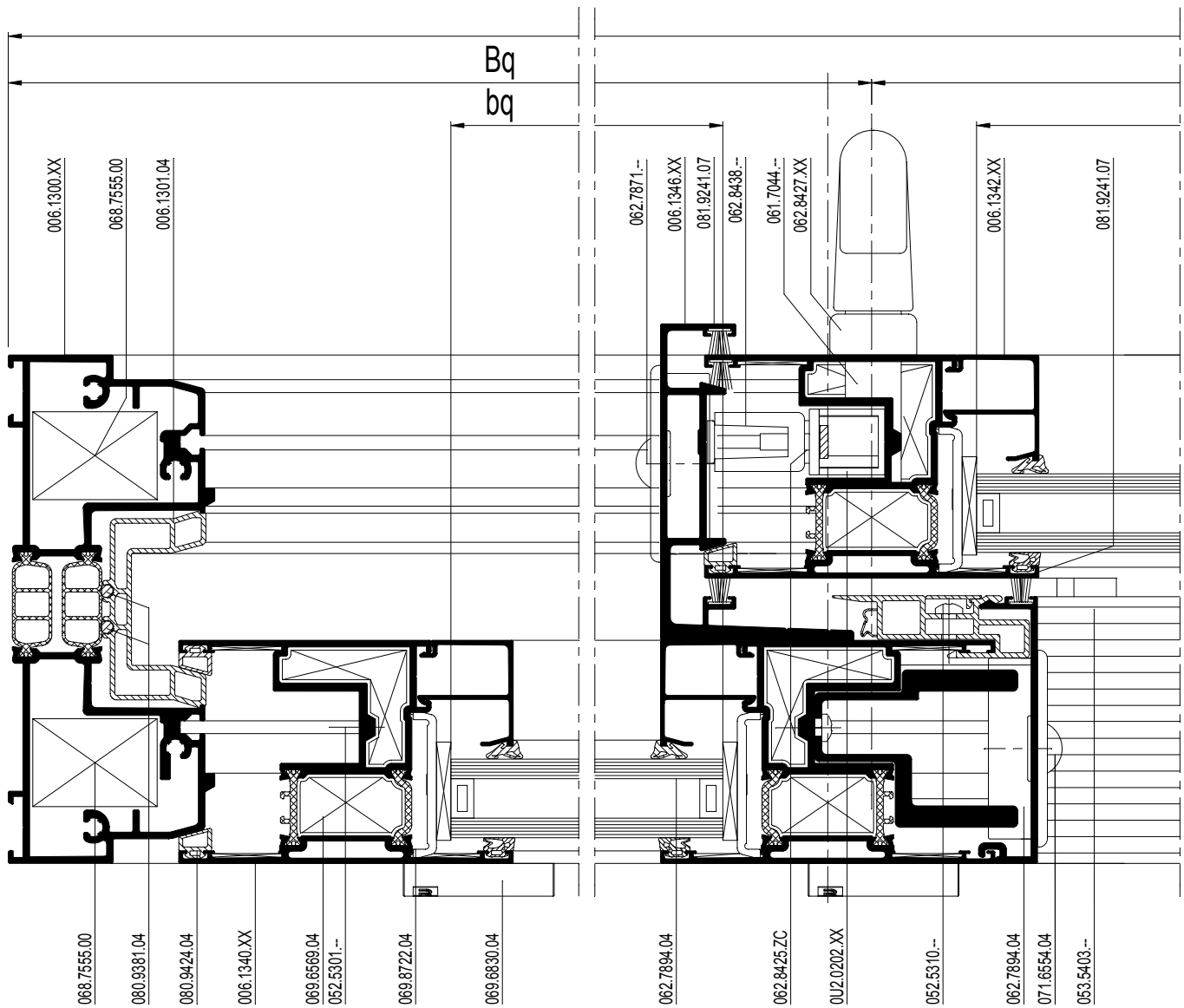

schaal - échelle
 Maßstab - scale
 1/2

D0046634

CP 155

2-RAIL OXO
 2-RAIL OXO
 2-RAIL OXO
 2-RAIL OXO



		or		or	
	---		---		097.0437.00
	---		---		---

		or	
	095.A700.00		095.B300.00
	095.A730.00		095.B323.00

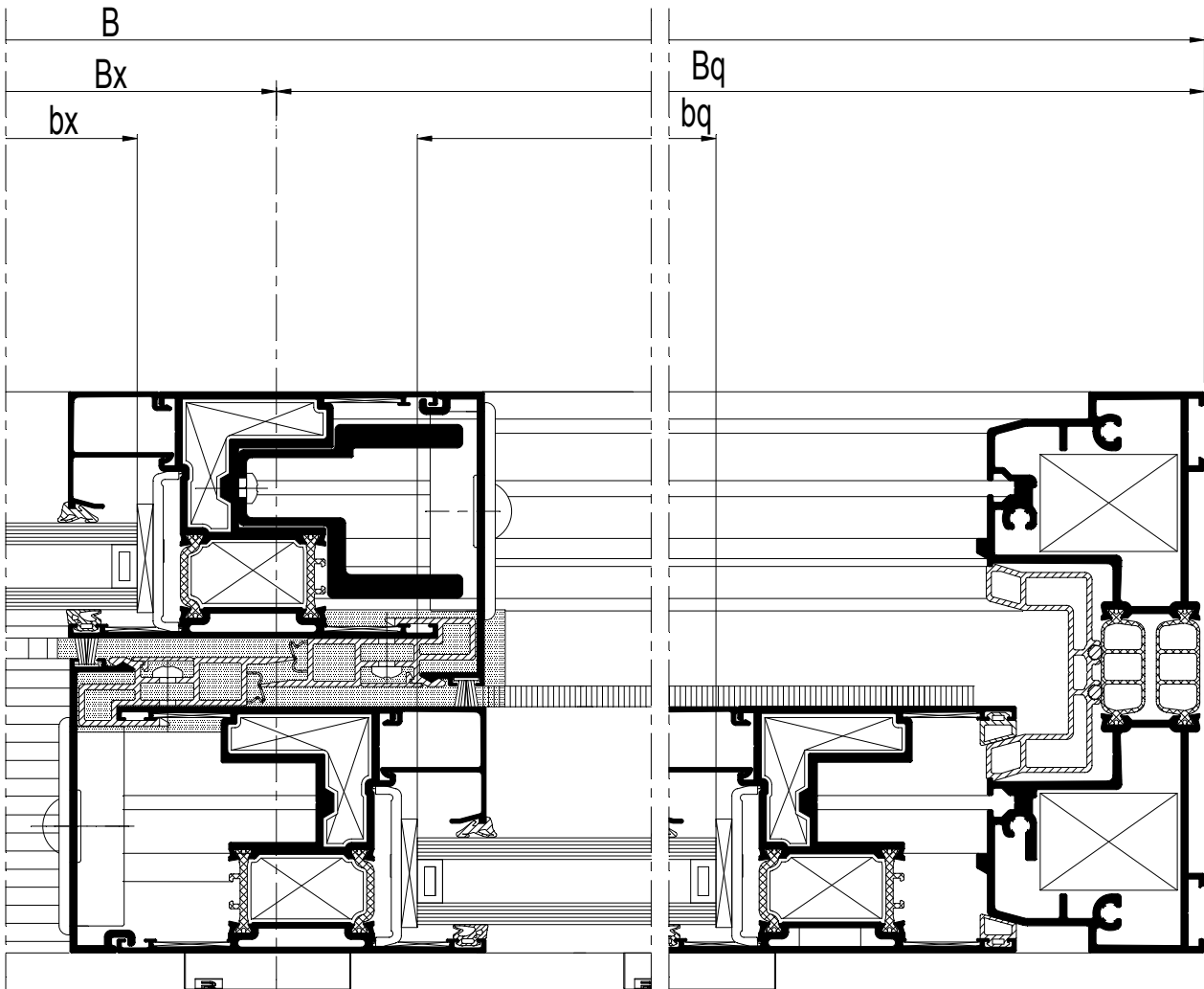

schaal - échelle
 Maßstab - scale
 1/2

D004634

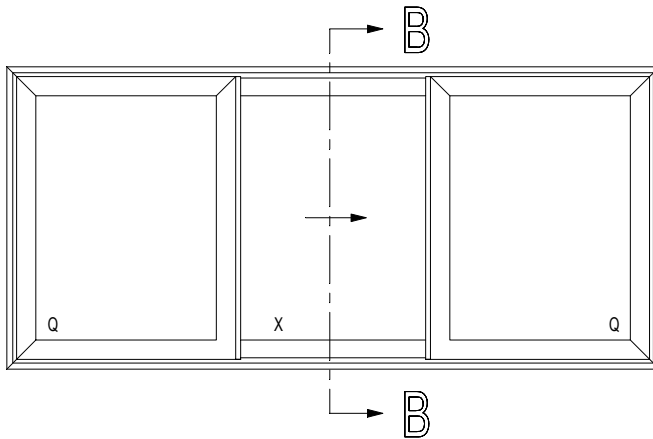

			#	L_m	
006.1300.XX			2	B	34.C....
006.1301.04			2	H	
011.4631.--			1	B-106	34.C....
006.1340.XX			2	Bx+89	34.C....
			4	Bq-7.5	
			6	H-104	
006.1342.XX			3	H-104	34.C....
006.1346.XX			1	H-104	34.C....
006.1341.04			3	H-104	34.C....
006.1343.00			2	H-162	34.C....
0U2.0202.XX.			1	280MM	34.C....
				(062.8425.ZC) OF-OU-OR-ODER	
			1	H-214 (062.8426.ZC)	
030.3614.XX			2	Bx-65	34.C....
			4	Bq-161.5	
			6	H-308	
006.0360.XX			2	Bx-121	34.C....



bx = Bx-77
hx = H-270
bq = Bq-173.5
ho = H-270

VLEUGELGEWICHT POIDS DU VANTAIL WEIGHT OF THE VENT FLÜGELGEWICHT	MAX. 250KG
---	------------

(*)

		#	
068.7555.00		8	34.G....
068.7775.00		12	34.G....
069.6569.04		12	34.G....
060.8723.--		36	34.G....
062.7894.04		4	34.G....
052.5317.--		8	34.G....
071.6554.04		8	34.G....
062.7927.04		min. 12	34.G....
062.8425.ZC		1	34.G....
062.8426.ZC		1	34.G....
052.5313.--		2	34.G....
062.8438.--		1	34.G....
052.5318.--		2	34.G....
062.7718.04		1	34.G....
062.8427.XX		1	34.G....
062.8429.XX		1	34.G....
061.7044.--		1	34.G....
062.7715.XX		1	34.G....
050.5051.--		1	34.G....
062.7834.--		2	34.G....
052.5372.--		4	34.G....
062.8038.07		12	34.G....
052.5301.--		12	34.G....
052.5304.--		12	34.G....
062.8025.04		2	34.G....
053.5403.--		8	34.G....
052.5310.--		3xH (3/m)	34.G....
052.5317.--		2xH (3/m)	34.G....
052.5332.--		H (6/m)	34.G....
052.5317.--		2	34.G....
069.8722.04		24	34.G....
062.6857.04		1	34.G....
069.6830.04		min. 2	34.G....
080.9424.04		5xH	34.G....
080.9104.SY		(2xB)+(6xH)	34.G....
080.9114.SY		(2xB)+(6xH)	34.G....
080.9381.04		(4xB)+(4xH)	34.G....
081.9241.07		(4xB)+(5xH)	34.G....
		+(2xBx)	

Afhankelijk van de hoogte
Dépend de l'hauteur
(*) Dependent of the height
Von der Höhe abhängig

B - B

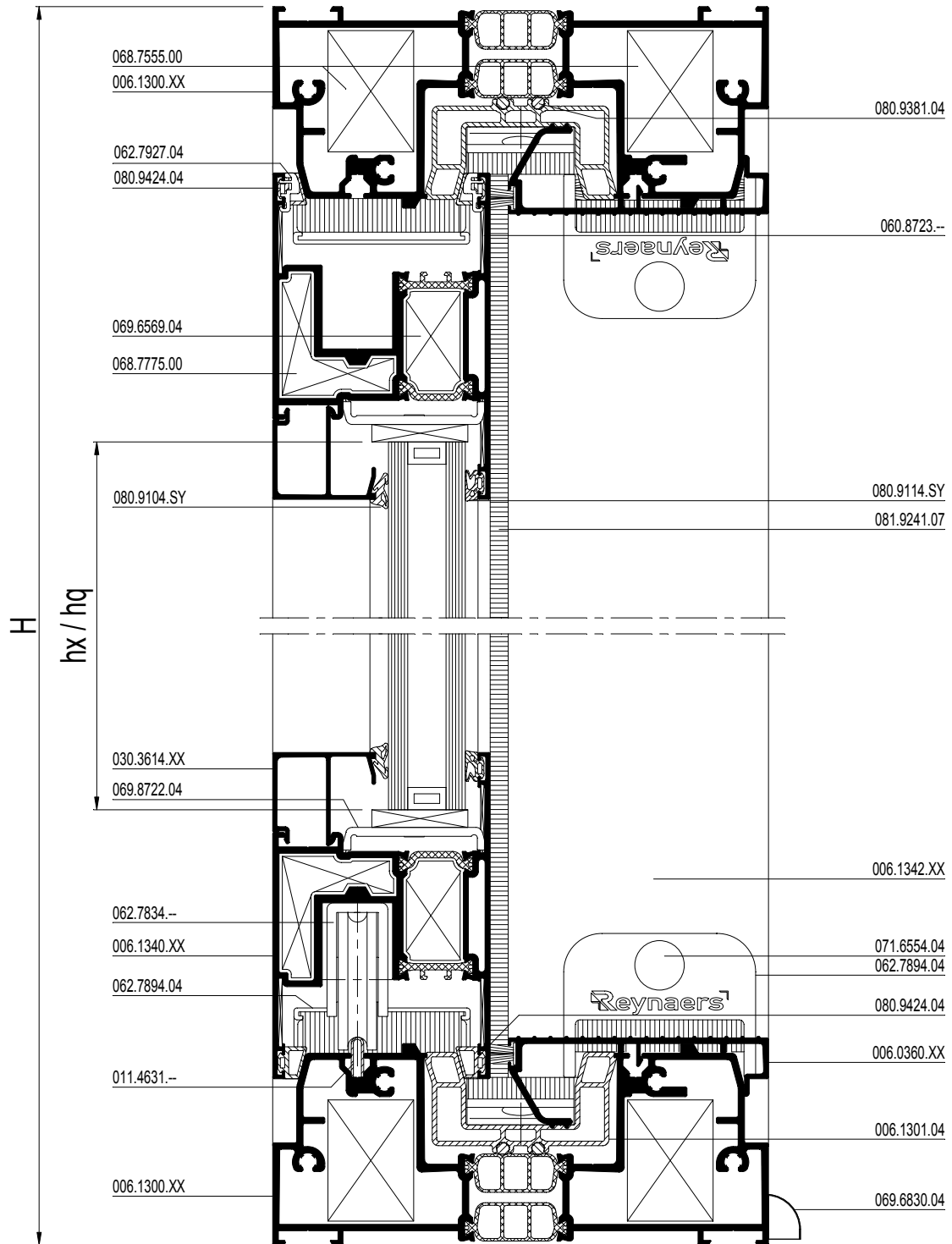

schaal - échelle
 Maßstab - scale
 1/2

D0046635

VLEUGELGEWICHT POIDS DU VANTAIL WEIGHT OF THE VENT FLÜGELGEWICHT	MAX. 250KG
---	------------

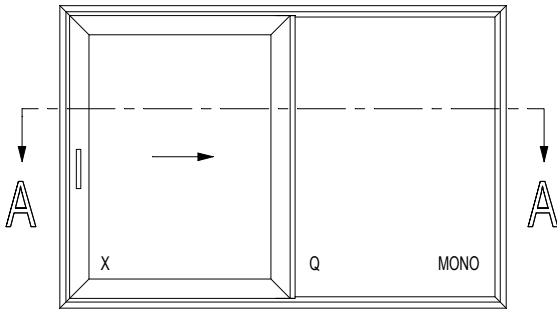

A - A

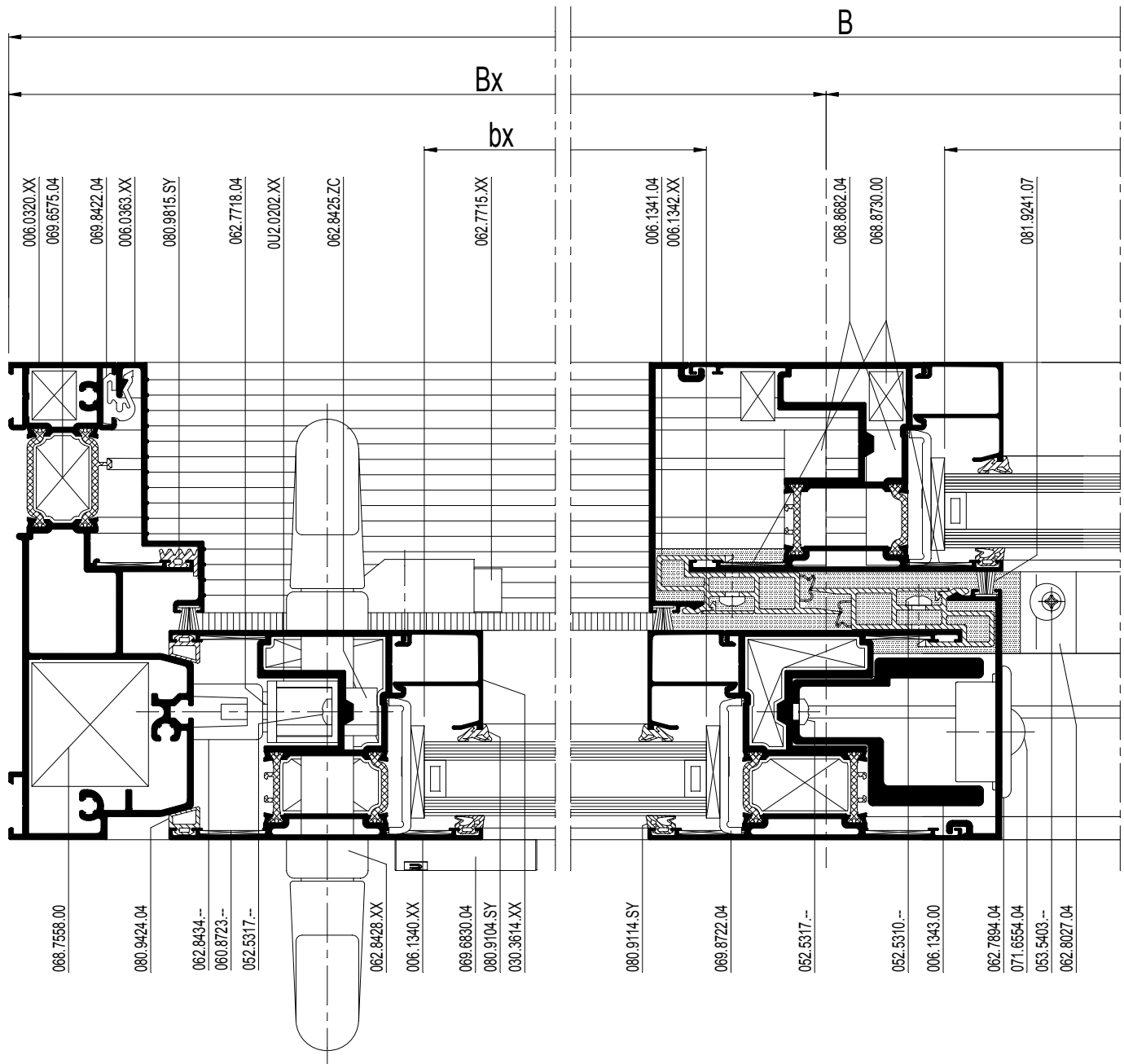

schaal - échelle
 scale - Maßstab
 1/2
 D0013923

CP 155

MONORAIL XQ
 MONORAIL XQ
 MONORAIL XQ
 MONORAIL XQ



		or		or	097.0437.00
	---		---		

		or	
	095.A700.00	or	095.B300.00
	095.A730.00		095.B323.00

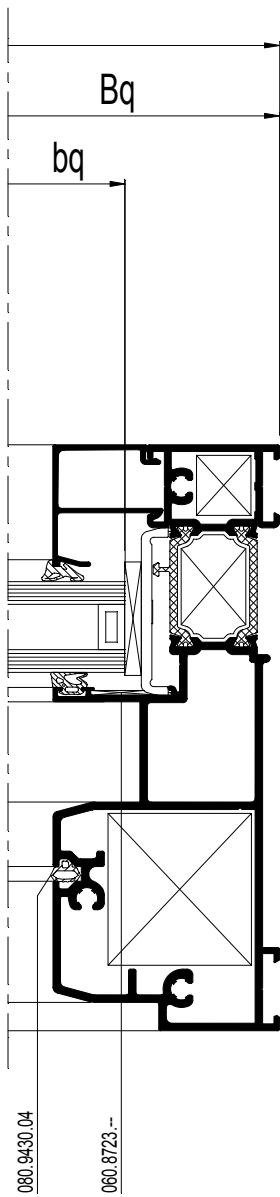

schaal - échelle
 scale - Maßstab
 1/2

D0013923

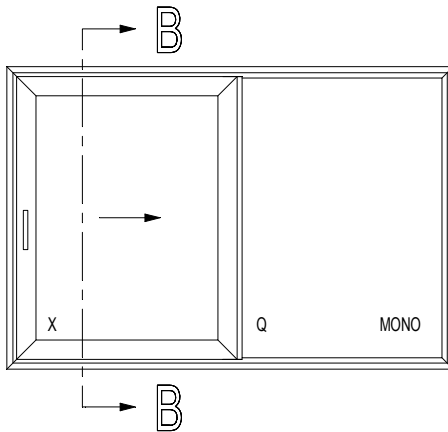

bx = Bx-173.5
hx = H-270
bq = Bq-80
hq = H-82

			#	Lm	
006.0320.XX			2	B	34.C....
			2	H	
011.4631.--			1	B-106	34.C....
006.0362.XX			2	Bx-92.5	34.C....
006.0363.XX			1	H-128	34.C....
006.1340.XX			2	Bx-7.5	34.C....
			2	H-104	
			1	H-70	
006.1342.XX			1	H-104	34.C....
			1	H-70	
006.1341.04			2	H-104	34.C....
006.1343.00			1	H-162	34.C....
OU2.0202.XX.			1	280MM	34.C....
				(062.8425.ZC) <small>OF-OU-OR-ODER</small>	
			1	H-214 (062.8426.ZC)	
030.3614.XX			2	Bx-161.5	34.C....
			2	H-308	
			2	Bq-67.5	
			2	H-120	

		#	
068.7558.00		4	34.G....
069.6575.04		4	34.G....
068.8682.04		4	34.G....
068.7775.00		4	34.G....
069.6569.04		4	34.G....
060.8723.--		16	34.G....
068.8730.00		4	34.G....
052.5333.--		2	34.G....
050.5153.--		2	34.G....
062.7894.04		1	34.G....
052.5317.--		2	34.G....
071.6554.04		2	34.G....
062.7927.04		min.4	34.G....
062.8425.ZC		1	34.G....
062.8426.ZC		1	34.G....
052.5313.--		2	34.G....
062.8434.--		1	34.G....
052.5318.--		3	34.G....
062.7718.04		1	34.G....
062.8429.--		1	34.G....
062.8428.XX		1	34.G....
061.7038.--		1	34.G....
062.7715.XX		1	34.G....
050.5051.--		1	34.G....
062.7834.--		2	34.G....
052.5372.--		4	34.G....
062.8027.04		1	34.G....
053.5403.--		4	34.G....
052.5310.--		2xH (3/m)	34.G....
052.5317.--		H (3/m)	34.G....
052.5317.--		2	34.G....
069.8722.04		16	34.G....
069.8422.04		B (3/m)+H (3/m)	34.G....
069.6830.04		min. 2	34.G....
069.6747.04		2	34.G....
080.9424.04		2xH	34.G....
080.9104.SY		(2xB)+(4xH)	34.G....
080.9114.SY		(2xB)+(4xH)	34.G....
081.9241.07		(3xB)+(3xH)	34.G....
080.9430.04		H	34.G....
080.9815.SY		B+H	34.G....

(*)

Afhankelijk van de hoogte
Dépend de l'hauteur
Dependent of the height
Von der Höhe abhängig

VLEUGELGEWICHT POIDS DU VANTAIL WEIGHT OF THE VENT FLÜGELGEWICHT	MAX. 250KG
---	------------

B - B

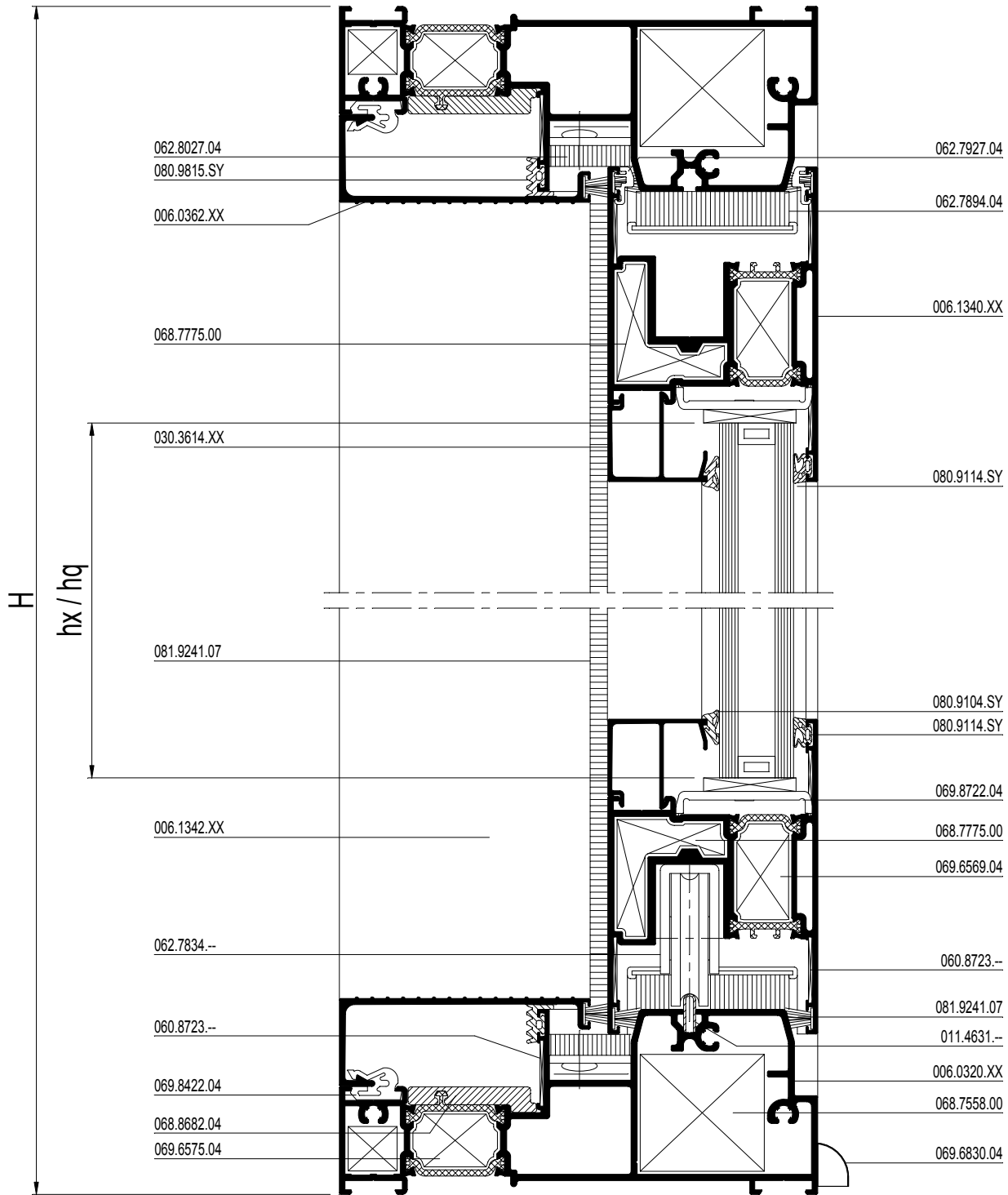

VLEUGELGEWICHT POIDS DU VANTAIL FLÜGELGEWICHT WEIGHT OF THE VENT	MAX. 250KG
---	------------

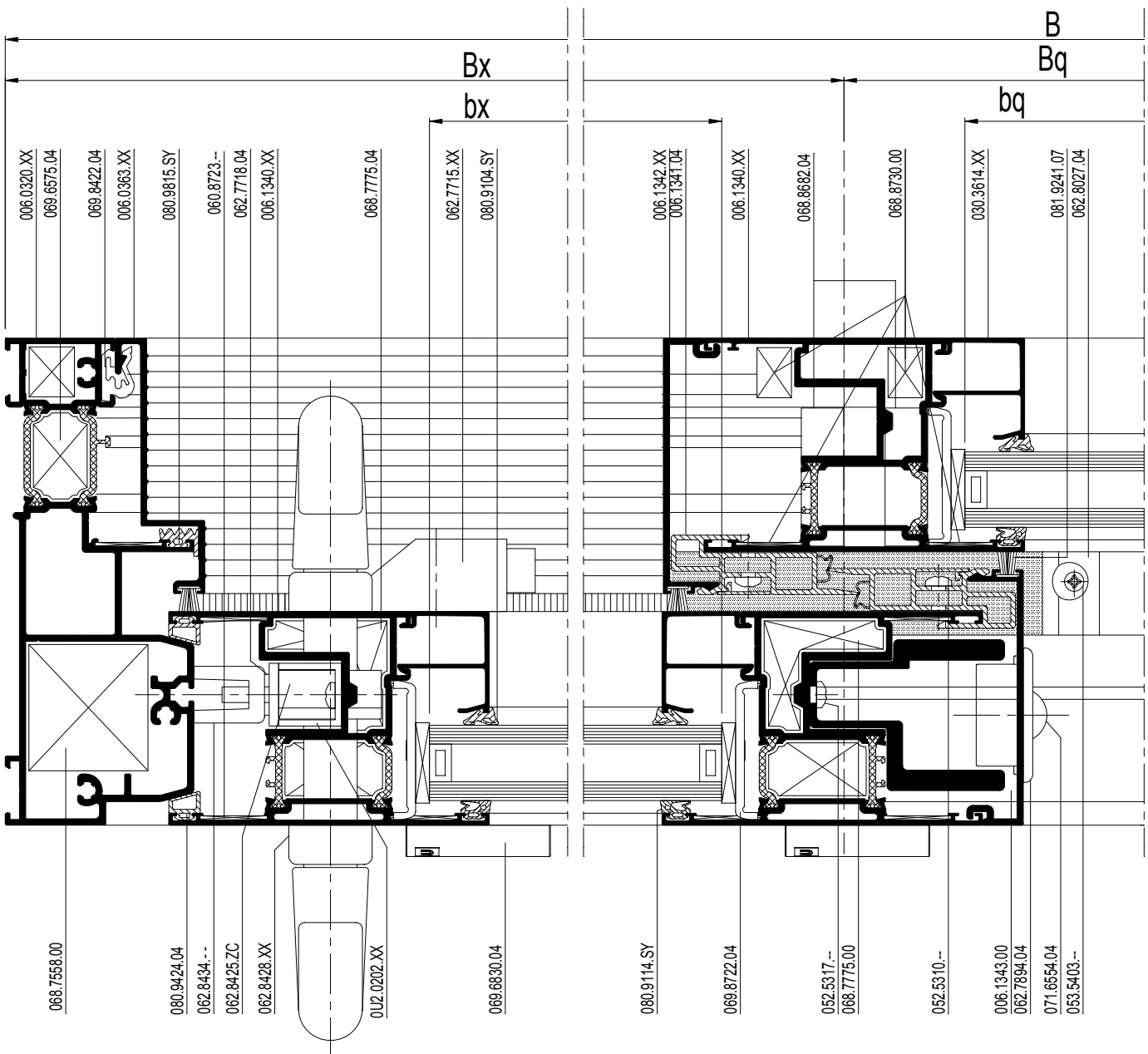
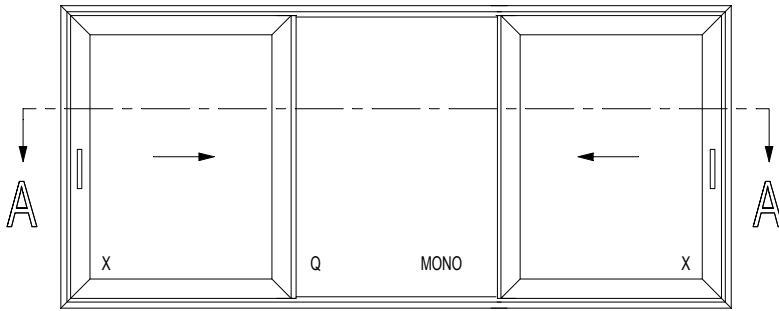

schaal - échelle
 scale - Maßstab
 1/2
 D0013925

		or		or	097.0437.00
	---	or	---	or	097.0437.00

		or	
	095.A700.00 or 095.B300.00	or	095.B323.00
	095.A730.00		095.B323.00

A - A

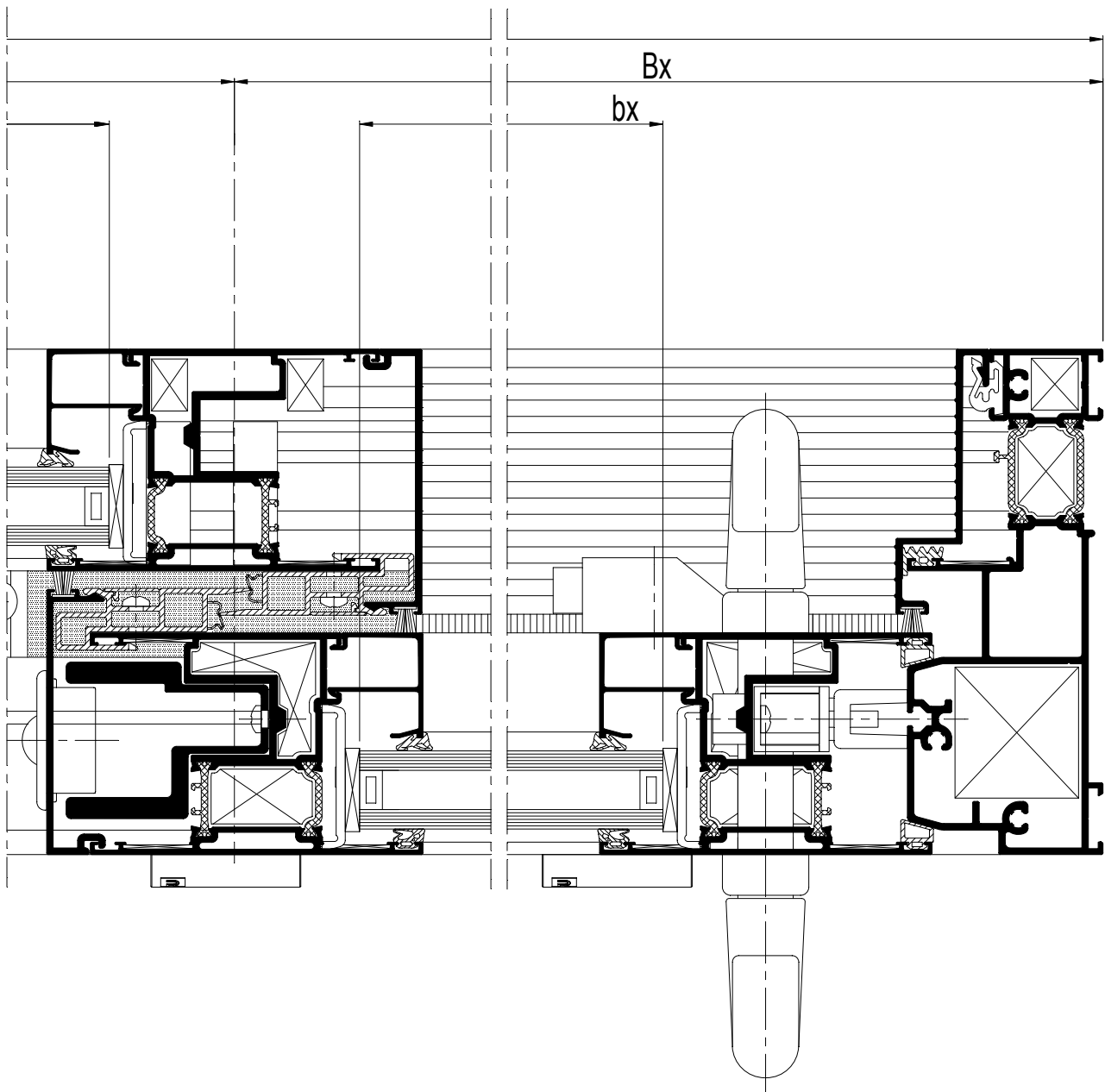

schaal - échelle
 scale - Maßstab
 1/2

D0013925

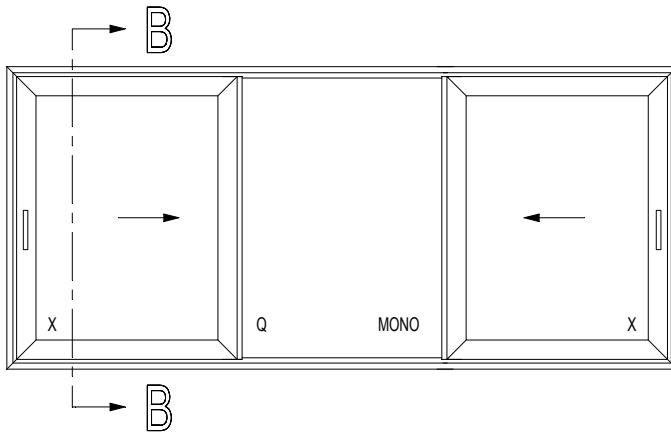

			#	$\leftarrow L_m \rightarrow$	
006.0320.XX			2	B	34.C....
			2	H	
011.4631.--			1	B-106	34.C....
006.0362.XX			4	Bx-92.5	34.C....
006.0363.XX			2	H-128	34.C....
006.1340.XX			4	Bx-7.5	34.C....
			4	H-104	
			2	H-70	
006.1342.XX			2	H-104	34.C....
			2	H-70	
006.1341.04			4	H-104	34.C....
006.1343.00			2	H-162	34.C....
0U2.0202.XX.			2	280MM	34.C....
				(062.8425.ZC)	
			2	H-214	
				(062.8426.ZC)	
030.3614.XX			4	Bx-161.5	34.C....
			2	Bq-65	
			4	H-308	
			2	H-120	



bx = Bx-173.5
hx = H-270
bq = Bq-77
hq = H-82

VLEUGELGEWICHT POIDS DU VANTAIL WEIGHT OF THE VENT FLÜGELGEWICHT	MAX. 250KG
---	------------

		#	
068.7558.00		4	34.G....
069.6575.04		4	34.G....
068.8682.04		8	34.G....
068.7775.00		8	34.G....
069.6569.04		8	34.G....
060.8723.--		28	34.G....
068.8730.00		8	34.G....
052.5333.--		4	34.G....
050.5153.--		4	34.G....
062.7894.04		2	34.G....
052.5317.--		4	34.G....
071.6554.04		4	34.G....
062.7927.04		min.8	34.G....
062.8425.ZC		2	34.G....
062.8426.ZC		2	34.G....
052.5313.--		4	34.G....
062.8434.--		2	34.G....
052.5318.--		6	34.G....
062.7718.04		2	34.G....
062.8429.--		2	34.G....
062.8428.XX		2	34.G....
061.7038.--		2	34.G....
062.7715.XX		2	34.G....
050.5051.--		2	34.G....
062.7834.--		4	34.G....
052.5372.--		8	34.G....
062.8027.04		2	34.G....
053.5403.--		8	34.G....
052.5310.--		4xH (3/m)	34.G....
052.5317.--		2xH (3/m)	34.G....
052.5317.--		4	34.G....
069.8722.04		24	34.G....
069.8422.04		4xBx (3/m)	34.G....
069.8422.04		2xH (3/m)	34.G....
069.6830.04		min. 2	34.G....
069.6747.04		4	34.G....
080.9104.SY		(2xB)+(6xH)	34.G....
080.9114.SY		(2xB)+(6xH)	34.G....
080.9424.04		4xH	34.G....
081.9241.07		(4xB)+(6xH)	34.G....
080.9815.SY		(4xBx)+(2xH)	34.G....

(*)

(*) Afankelijk van de hoogte
Dépend de l'hauteur
Dependent of the height
Von der Höhe abhängig

B - B

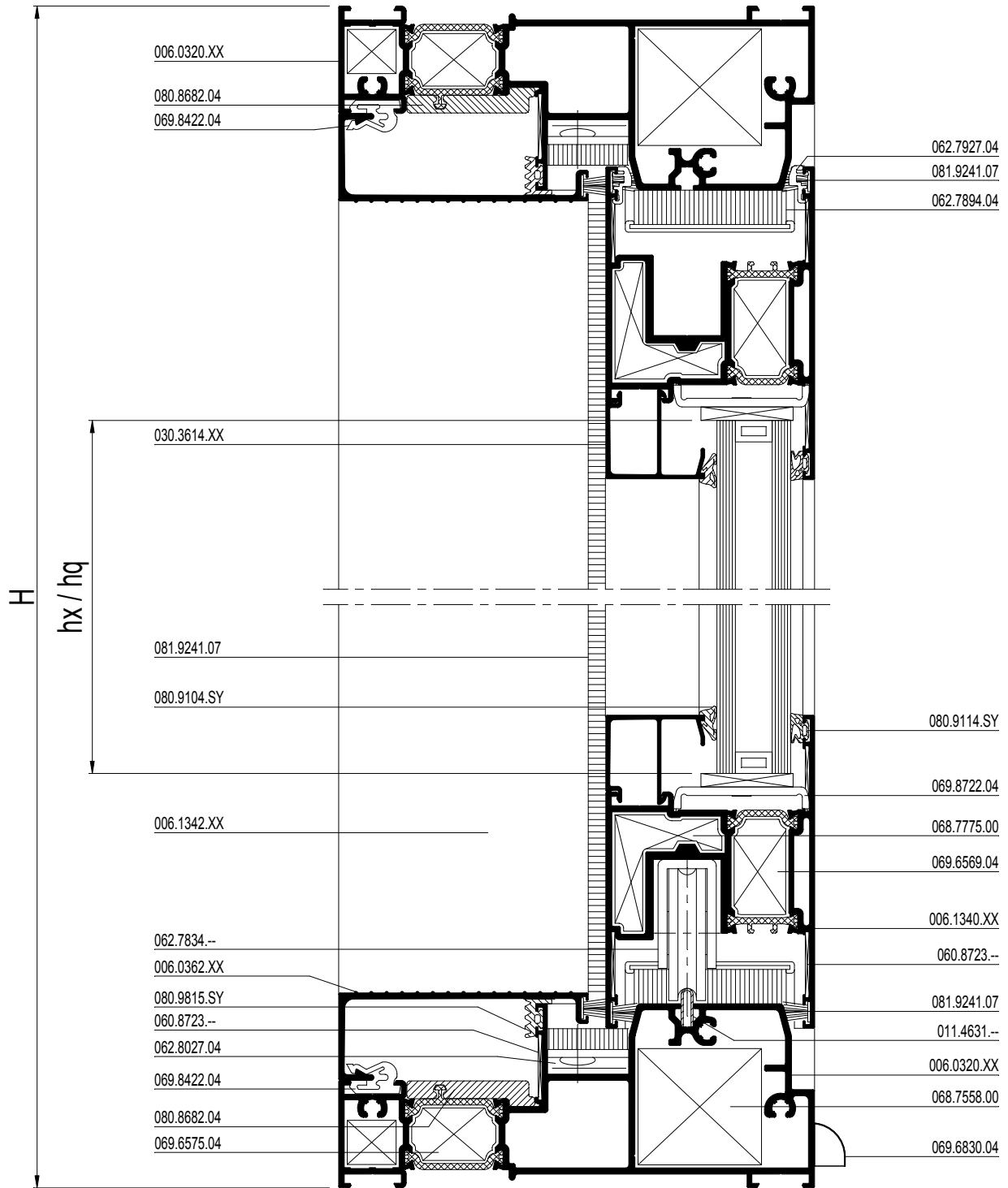

schaal - échelle
 scale - Maßstab
 1/2

D0013926

VLEUGELGEWICHT POIDS DU VANTAIL WEIGHT OF THE VENT FLÜGELGEWICHT	MAX. 250KG
---	------------

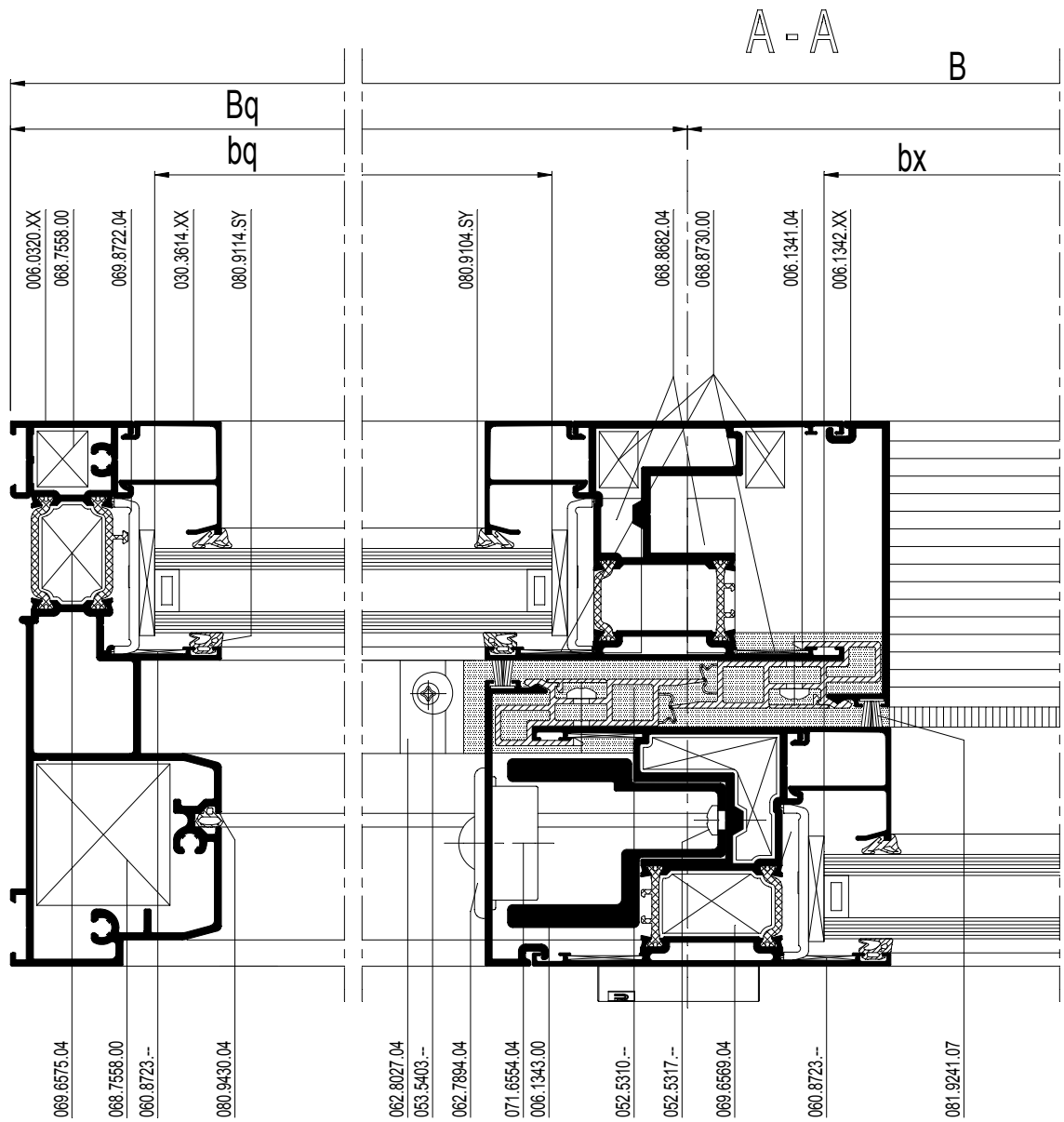
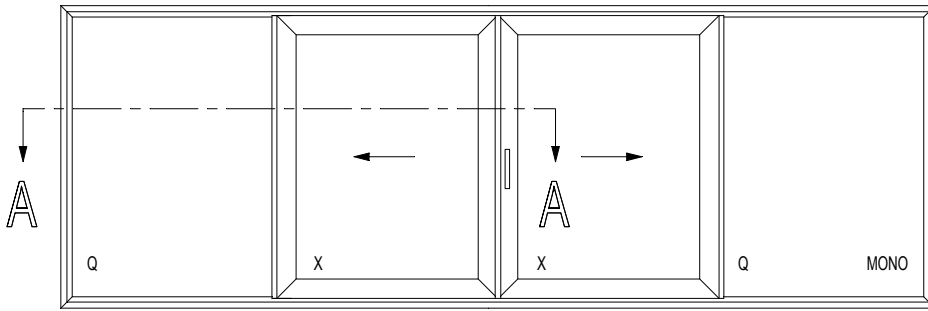

schaal - échelle
 scale - Maßstab
 1/2
 D0013927

	---	or	---
			097.0437.00

	095.A700.00 or 095.B300.00	
	095.A730.00	095.B323.00

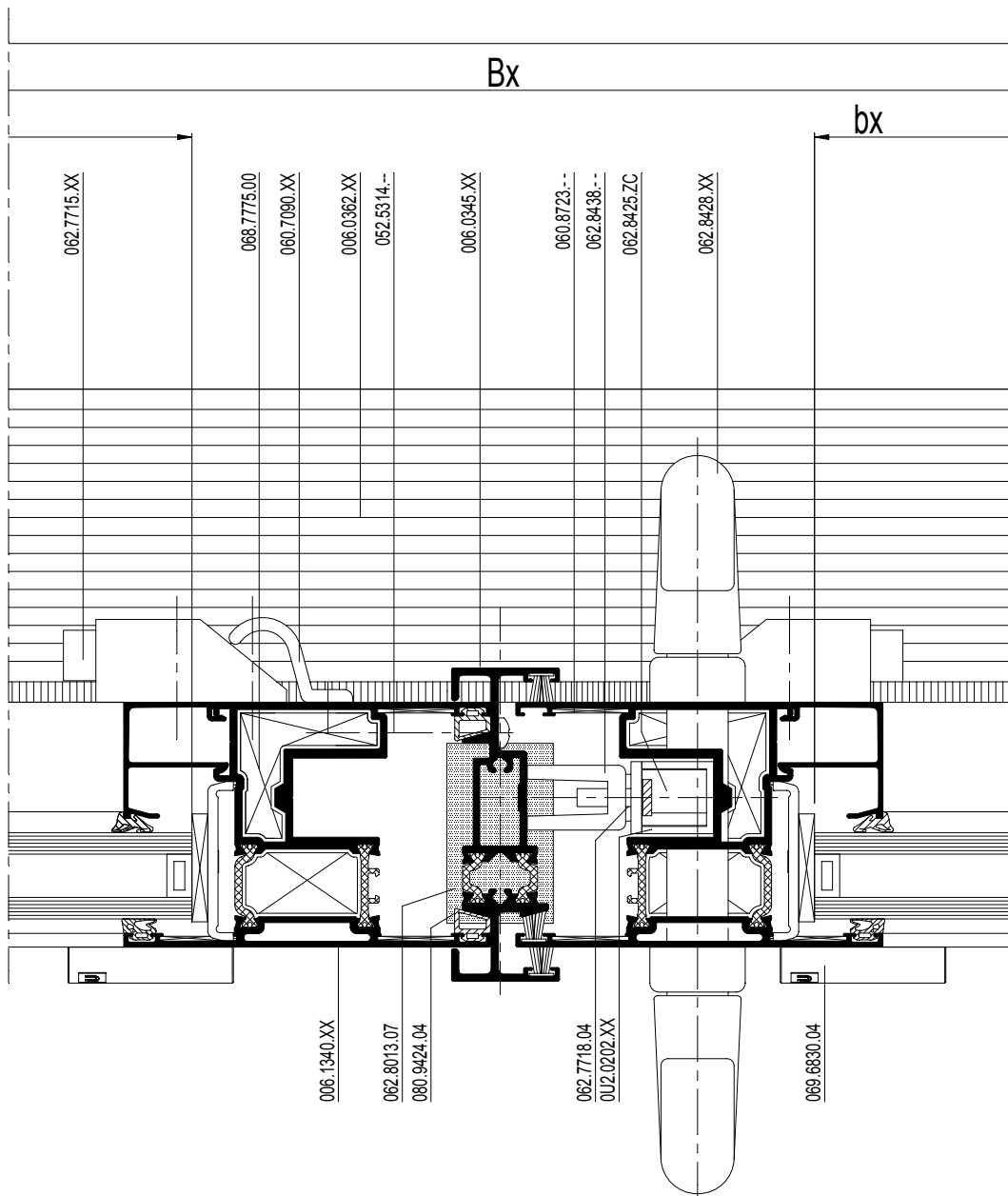

schaal - échelle
 scale - Maßstab
 1/2

D0013927

VLEUGELGEWICHT POIDS DU VANTAIL WEIGHT OF THE VENT FLÜGELGEWICHT	MAX. 250KG
---	------------

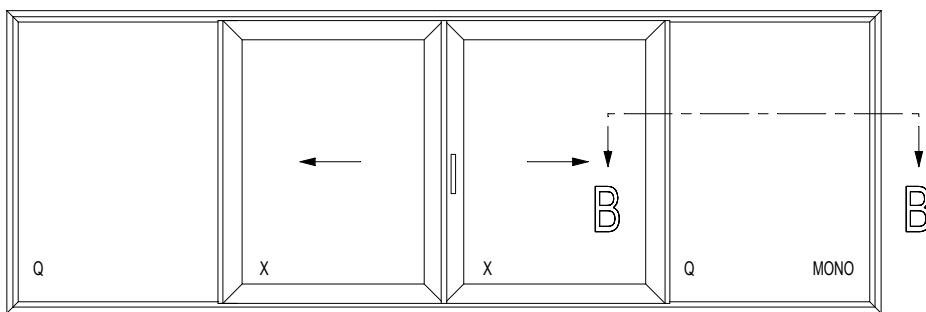



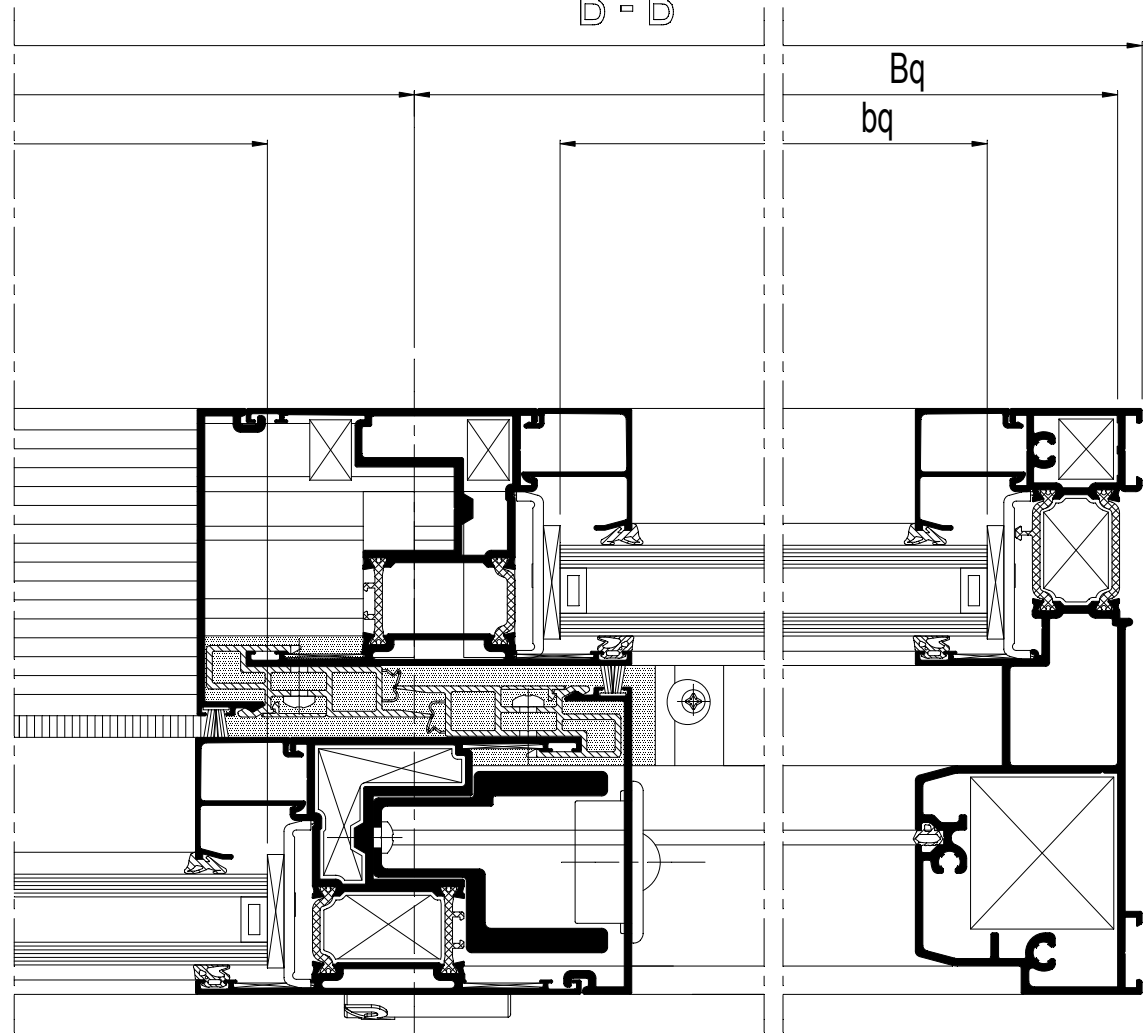











































B - B



schaal - échelle
 scale - Maßstab
 1/2

D0013928

		#	
068.7558.00		4	34.G...
069.6575.04		4	34.G...
068.8982.04		8	34.G...
068.7775.00		8	34.G...
069.6569.04		8	34.G...
060.8723.--		28	34.G...
068.8730.00		8	34.G...
052.5333.--		4	34.G...
050.5153.--		4	34.G...
062.7894.04		2	34.G...
052.5317.--		4	34.G...
071.6554.04		4	34.G...
062.7927.04		min.8	34.G...
062.8425.ZC		1	34.G...
062.8426.ZC		1	34.G...
052.5313.--		2	34.G...
062.8438.--		1	34.G...
052.5318.--		2	34.G...
062.7718.04		1	34.G...
062.8429.--		1	34.G...
062.8428.XX		1	34.G...
061.7038.--		1	34.G...
060.7090.XX		1	34.G...
052.5312.--		2	34.G...
062.7834.--		4	34.G...
052.5372.--		8	34.G...
062.8027.04		2	34.G...
053.5403.--		8	34.G...
062.7715.XX		2	34.G...
050.5051.--		2	34.G...
062.8013.07		1	34.G...
052.5317.--		4	34.G...
052.5310.--		4xH (3/m)	34.G...
052.5317.--		2xH (3/m)	34.G...
052.5317.--		2	34.G...
052.5314.--		H (3/m)	34.G...
069.8722.04		32	34.G...
069.8422.04		2xBx (3/m)	34.G...
069.6830.04		min. 2	34.G...
069.6747.04		4	34.G...
080.9104.SY		(2xB)+(8xH)	34.G...
080.9114.SY		(2xB)+(8xH)	34.G...
080.9424.04		2xH	34.G...
081.9241.07		(6xBx)+(7xH)	34.G...
080.9815.SY		2xBx	34.G...
080.9430.04		2XH	34.G...

(*)

(*) Afhankelijk van de hoogte
Dépend de l'hauteur
Dependent of the height
Von der Höhe abhängig

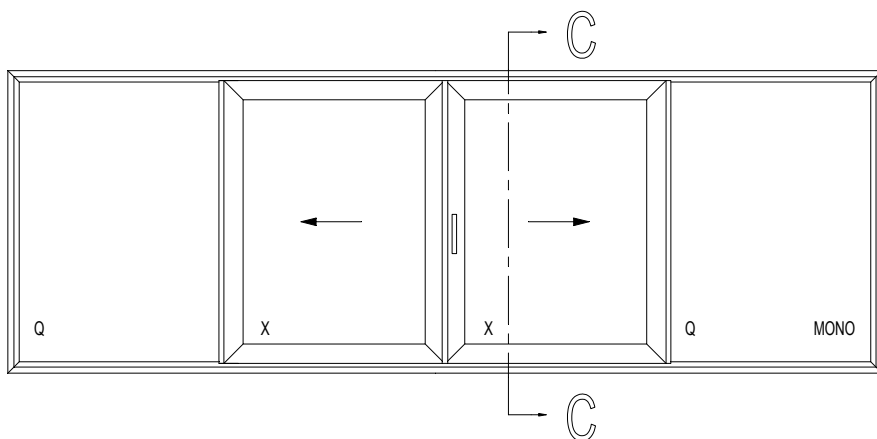

			#	$\leftarrow L_m \rightarrow$	
006.0320.XX			2	B	34.C....
			2	H	
011.4631.--			1	B-106	34.C....
006.0362.XX			2	Bx-115	34.C....
006.1340.XX			4	$(Bx:2)+41.75$	34.C....
			4	H-104	
			2	H-70	
006.1342.XX			2	H-104	34.C....
			2	H-70	
006.1341.04			4	H-104	34.C....
006.1343.00			2	H-162	34.C....
0U2.0202.XX.			1	280MM	34.C....
				(062.8425.ZC)	
			1	H-214	
				(062.8426.ZC)	
006.0345.XX			1	H-104	34.C....
030.3614.XX			4	$(Bx:2)-112.2$	34.C....
			4	H-308	
			4	Bq-67.5	
			4	H-120	

$bx = (Bx:2)-125$
$hx = H-270$
$bq = Bq-80$
$hq = H-82$

VLEUGELGEWICHT POIDS DU VANTAIL WEIGHT OF THE VENT FLÜGELGEWICHT	MAX. 250KG
---	------------

C - C

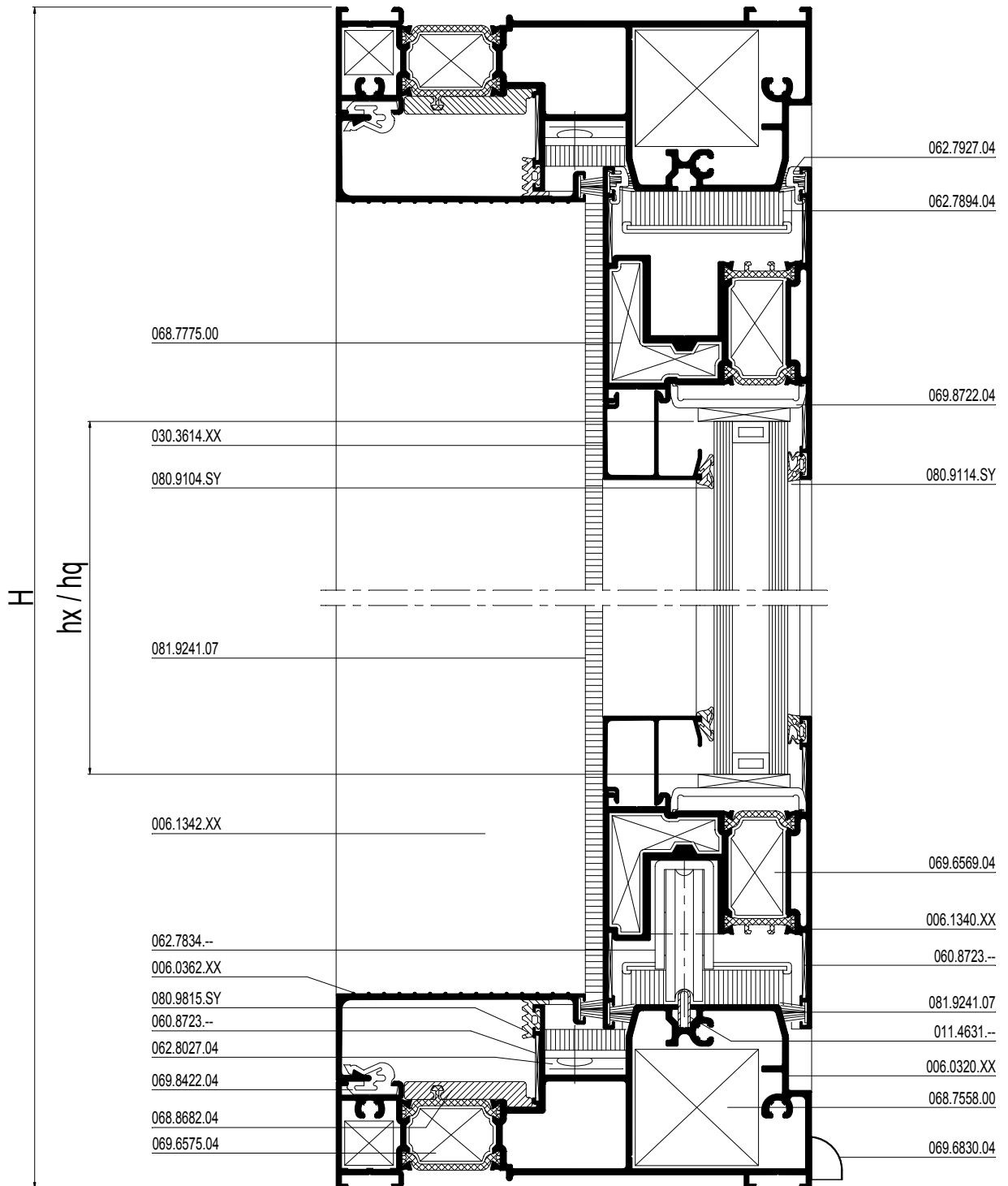

VLEUGELGEWICHT POIDS DU VANTAIL WEIGHT OF THE VENT FLÜGELGEWICHT	MAX. 250KG
---	------------

A - A

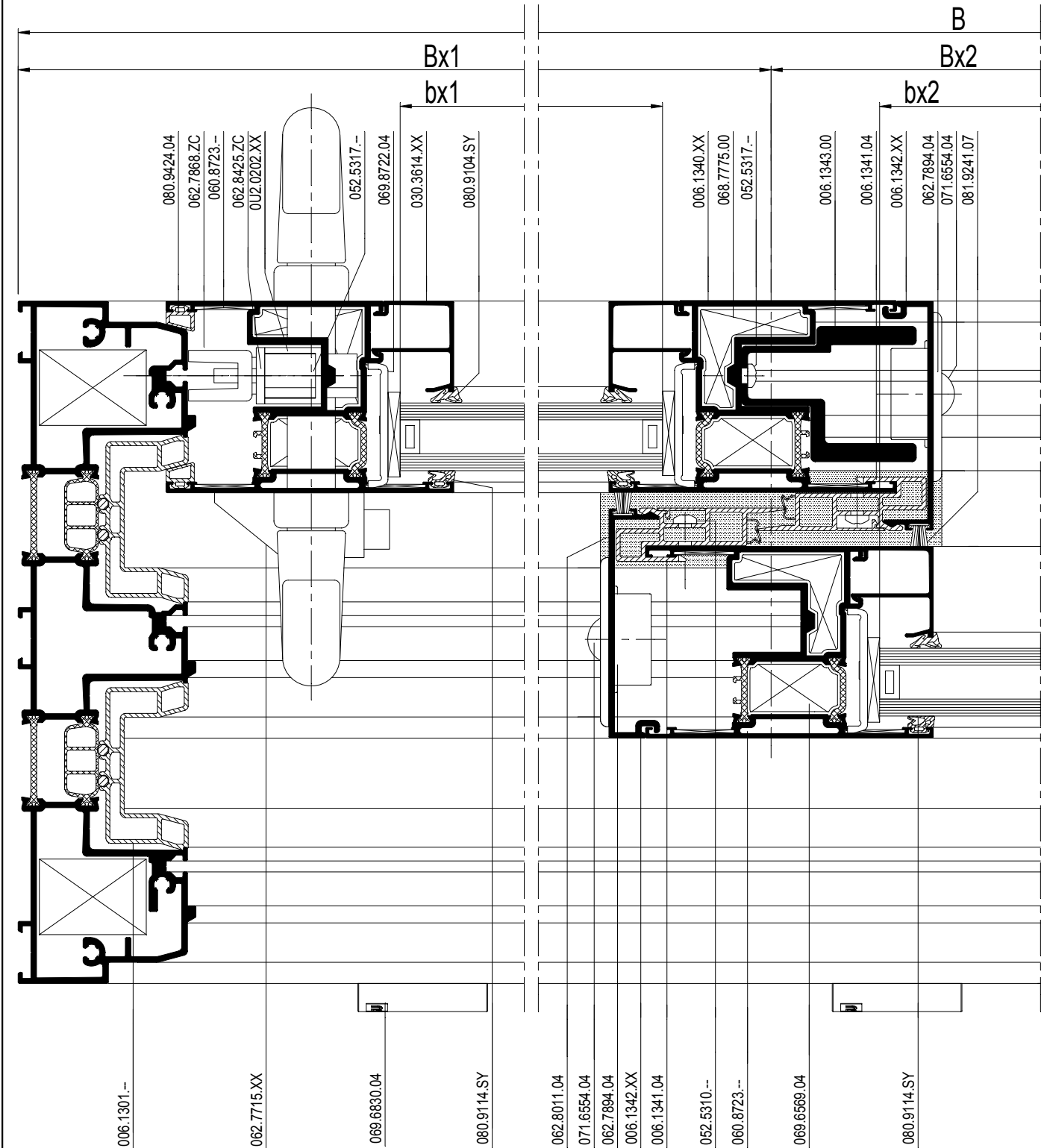

schaal - échelle
 scale - Maßstab
 1/2

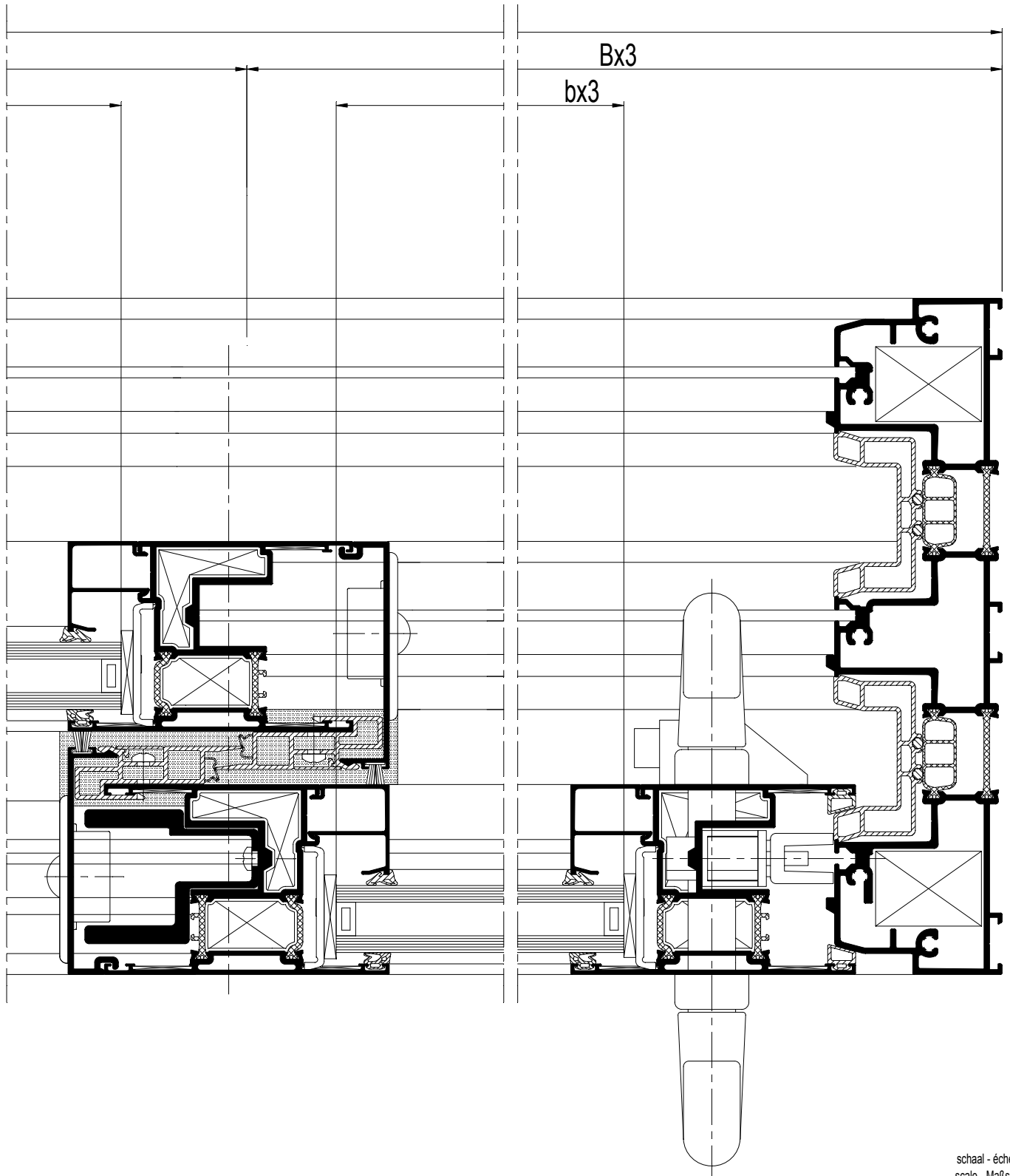

schaal - échelle
scale - Maßstab
1/2

D00045159

CP 155

3-RAIL XXX
3-RAIL XXX
3-RAIL XXX
3-RAIL XXX

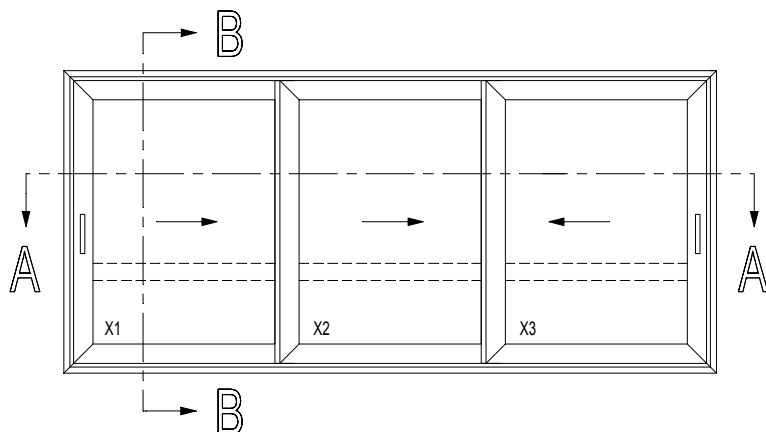

VLEUGELGEWICHT POIDS DU VANTAIL FLÜGELGEWICHT WEIGHT OF THE VENT	MAX. 250KG
---	------------

HOOGTE HAUTEUR HEIGHT HOEHE	MIN. 1895 MM
--------------------------------------	--------------

B - B

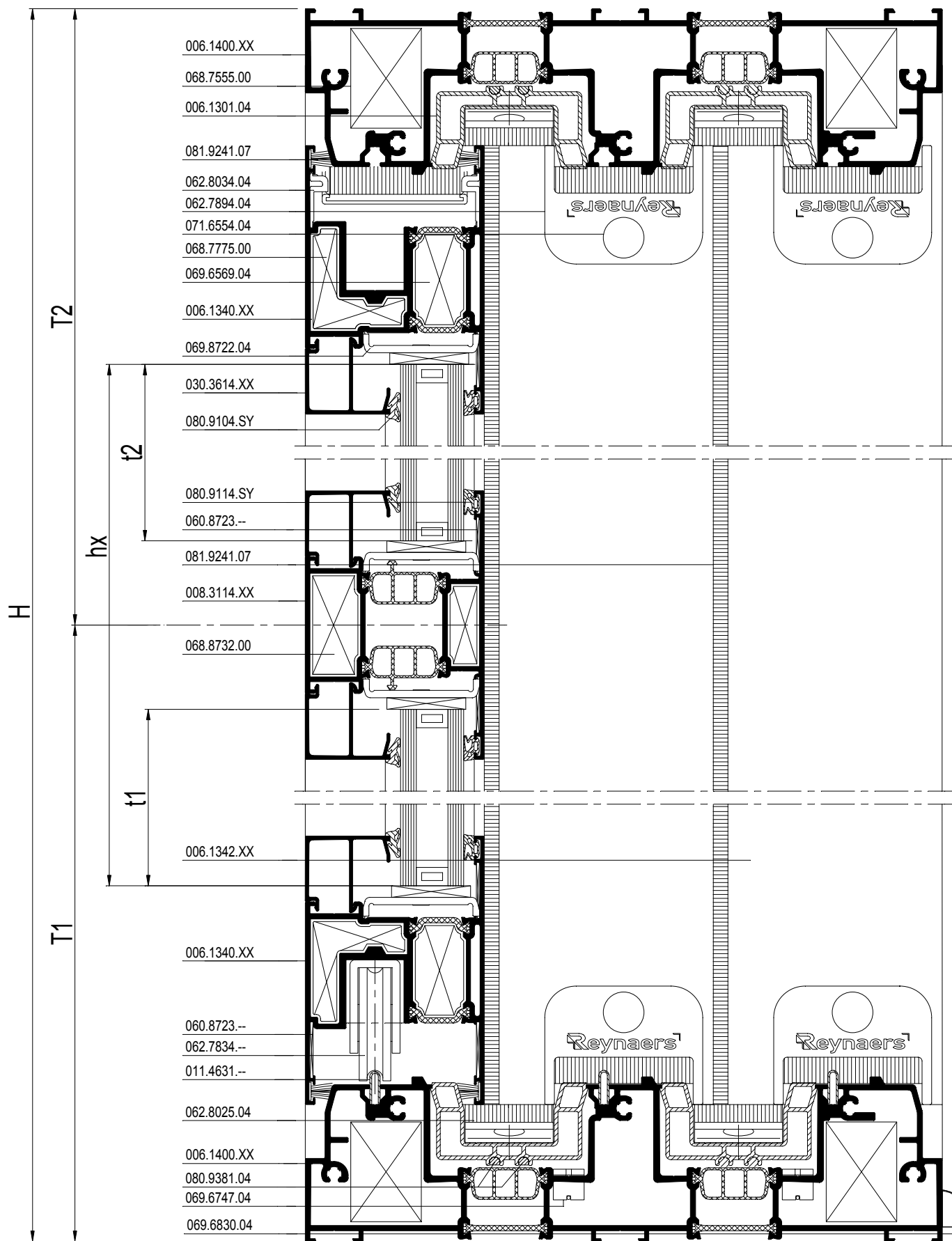



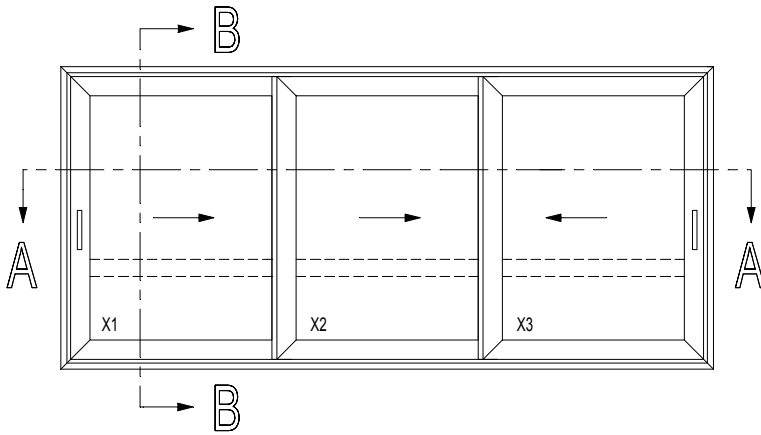





























D00045149







VLEUGELGEWICHT POIDS DU VANTAIL FLÜGELGEWICHT WEIGHT OF THE VENT	MAX. 250KG
---	------------

HOOGTE HAUTEUR HEIGHT HOEHE	MIN. 1895 MM
--------------------------------------	--------------

			#	← Lm →	
006.1400.XX			2	B	34.C....
			2	H	
006.1301.04			4	B	34.C....
			4	H	
011.4631.-			3	B-106	34.C....
006.1340.XX			2	Bx1-7.5	34.C....
			2	Bx2+89	
			2	Bx3-7.5	
			6	H-104	
006.1342.XX			4	H-104	34.C....
006.1341.04			4	H-104	34.C....
006.1343.XX			2	H-162	34.C....
0U2.0202.XX.			1	280MM	34.C....
				(062.8425.ZC) -OF-OU-OR-ODER	
			1	H-214	
030.3614.XX			2	Bx1-161.5	34.C....
			2	Bx2-65	
			2	Bx3-161.5	
			6	H-308	

met dwarsstijl
avec traverse
with transom
mit Sprossenprofil
+

008.3114.XX			1	Bx1-168	34.C....
			1	Bx2-78	
			1	Bx3-168	

bx1=Bx1-173.5
hx1=H-270
bx2=Bx2-77
hx2=H-270
bx3=Bx3-173.5
hx3=H-270

met dwarsstijl
avec traverse
with transom
mit Sprossenprofil

t1=T1-167
t2=T2-167

		#	
068.7555.00		8	34.G...
068.7775.00		12	34.G...
069.6569.04		12	34.G...
060.8723.--		36	34.G...
062.7894.04		4	34.G...
052.5317.--		8	34.G...
071.6554.04		8	34.G...
062.7927.04		12	34.G...
062.8425.ZC		2	34.G...
052.5313.--		4	34.G...
062.8434.--		2	34.G...
052.5318.--		6	34.G...
052.5317.--		4	34.G...
(*) 062.8426.ZC		2	34.G...
052.5313.--		26	34.G...
062.8440.--		2	34.G...
052.5318.--		22	34.G...
052.5317.--		16	34.G...
062.8428.XX		2	34.G...
062.8429.XX		2	34.G...
061.7038.--		2	34.G...
062.7834.--		6	34.G...
052.5372.--		12	34.G...
062.7718.04		2	34.G...
062.8025.XX		2	34.G...
053.5403.--		8	34.G...
062.7715.XX		2	34.G...
050.5051.--		2	34.G...
069.8722.04		24	34.G...
069.6830.04		min. 2	34.G...
080.9104.SY		(2xB)+(6xH)	34.G...
080.9114.SY		(2xB)+(6xH)	34.G...
080.9381.04		(8xB)+(8xH)	34.G...
080.9424.04		4xH	34.G...
081.9241.07		(4xB)+(4xH)	34.G...
052.5310.--		4xH (3/m)	34.G...
052.5317.--		2xH (3/m)	34.G...
062.6857.04		2	34.G...

met dwarsstijl
avec traverse
with transom
mit Sprossenprofil
+

068.8732.00		6	34.G...
069.8722.04		24	34.G...
080.9104.SY		2xB	34.G...
080.9114.SY		2xB	34.G...

(*) Afhankelijk van de hoogte
Dépend de l'hauteur
Dependent of the height
Von der Höhe abhängig

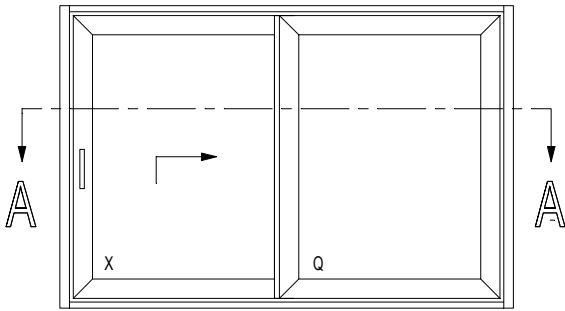

VLEUGELGEWICHT POIDS DU VANTAIL WEIGHT OF THE VENT FLÜGELGEWICHT	MAX. 250KG
---	------------

HOOGTE HAUTEUR HEIGHT HOEHE	MIN. 1895 MM
--------------------------------------	--------------

A - A

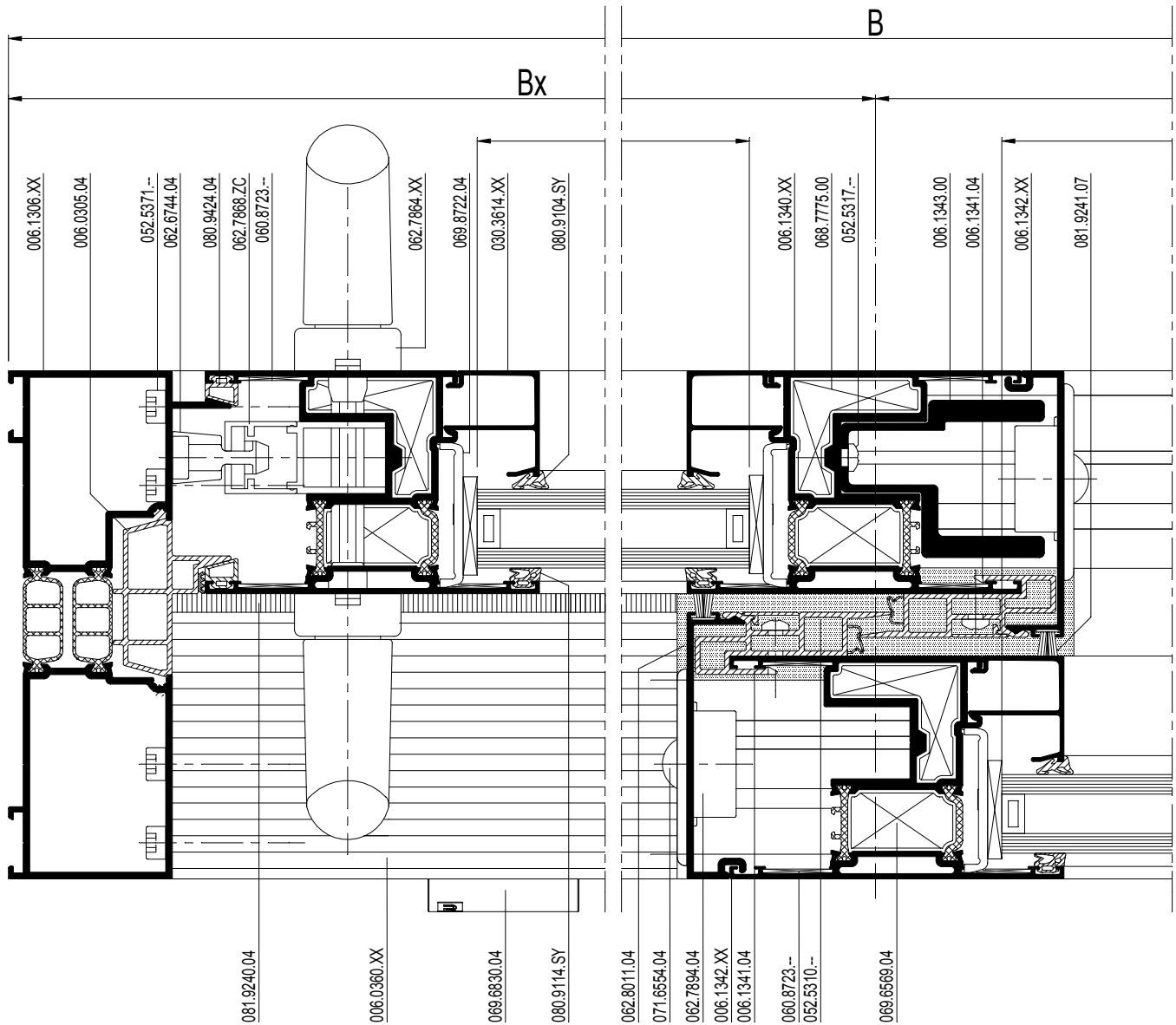

CP 155-LS

2-RAIL XO
 2-RAIL XO
 2-RAIL XO
 2-RAIL XO



		or		
	---	or	---	or 097.0436.00
	---	or	---	or 097.0437.00

		or	
	095.A700.00	or	095.B300.00
	095.A730.00		095.B323.00

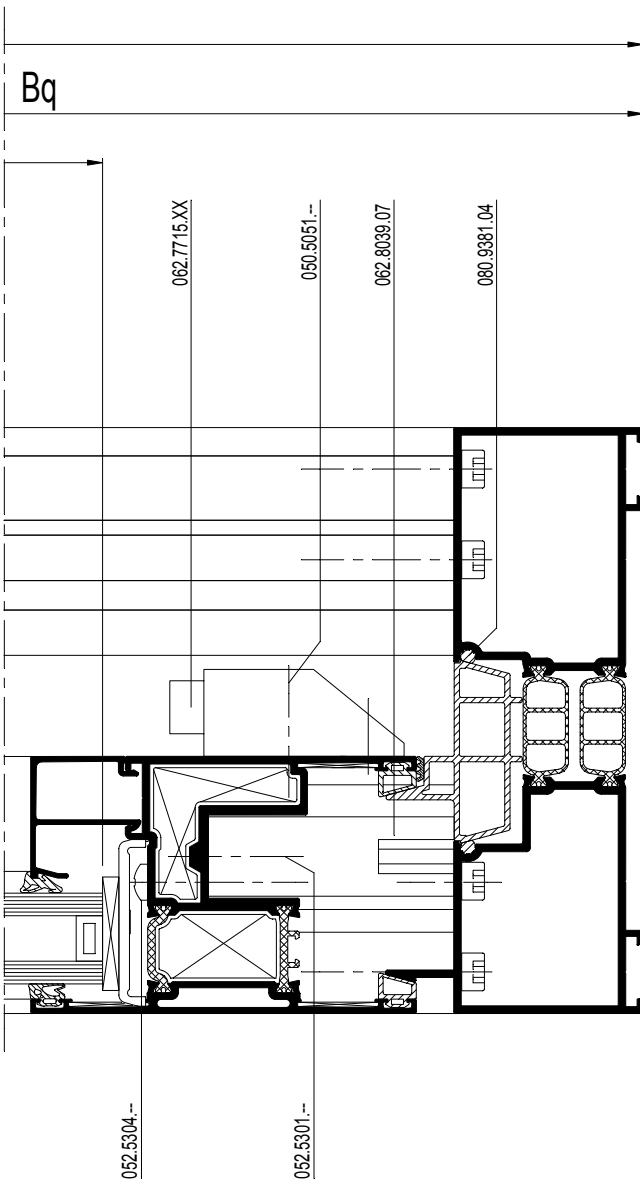

CP 155-LS

2-RAIL XQ FLAT BOTTOM
 2-RAIL XQ FLAT BOTTOM
 2-RAIL XQ FLAT BOTTOM
 2-RAIL XQ FLAT BOTTOM

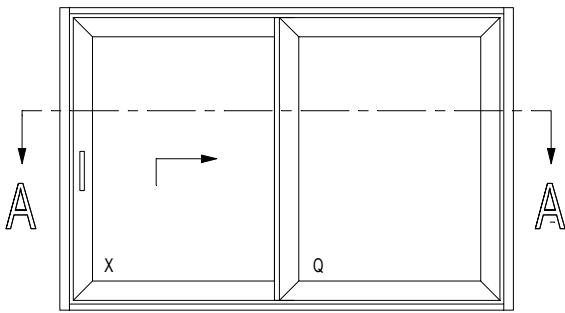

VLEUGELGEWICHT POIDS DU VANTAIL WEIGHT OF THE VENT FLÜGELGEWICHT	MAX. 250KG
---	------------

HOOGTE HAUTEUR HEIGHT HOEHE	MIN. 1895 MM
--------------------------------------	--------------

A - A

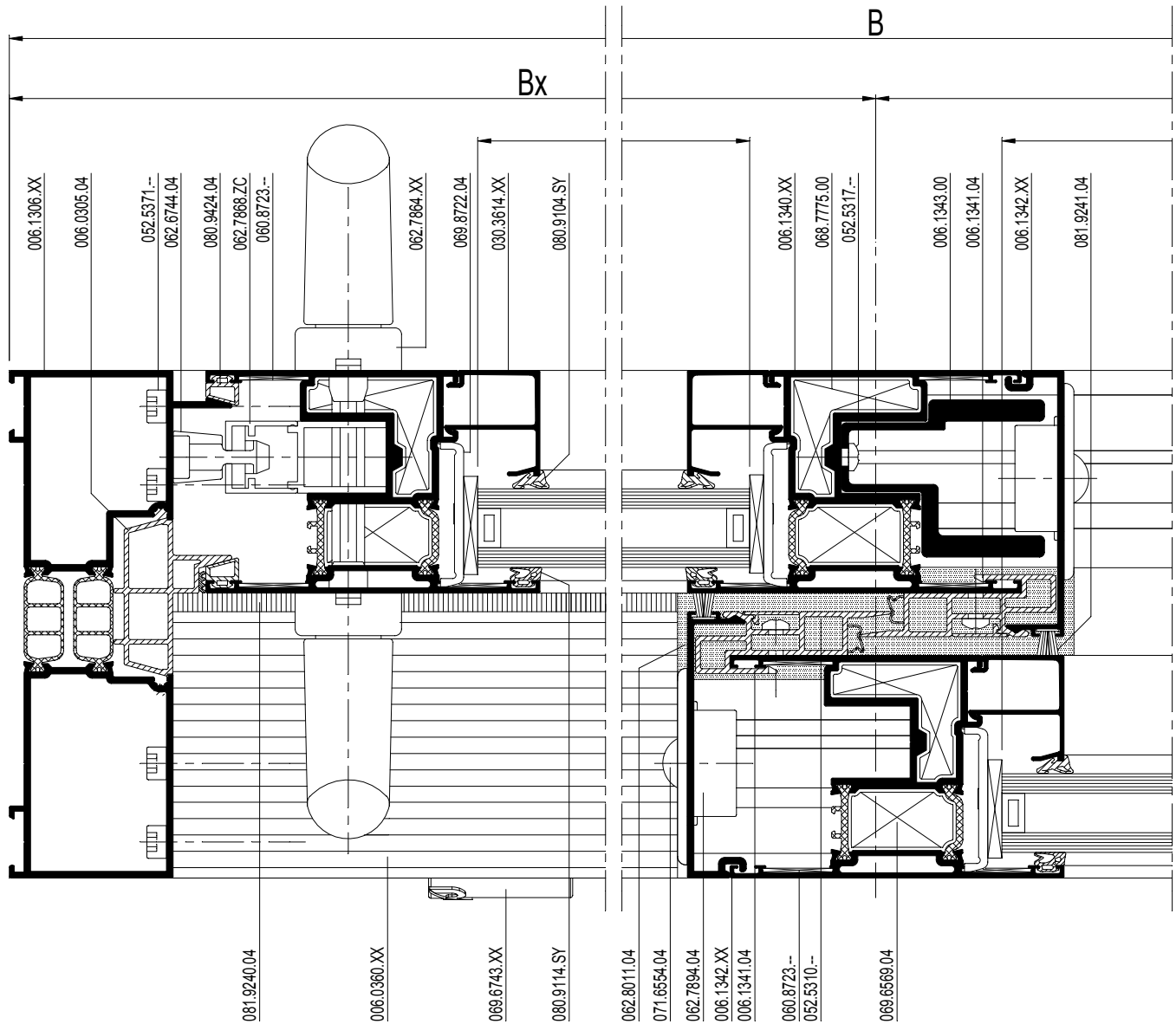

D0074742

CP 155-LS

2-RAIL XQ FLAT BOTTOM
 2-RAIL XQ FLAT BOTTOM
 2-RAIL XQ FLAT BOTTOM
 2-RAIL XQ FLAT BOTTOM



		or		
	---	or	---	or 097.0436.00
	---	or	---	or 097.0437.00

		or	
	095.A700.00	or	095.B300.00
	095.A730.00		095.B323.00

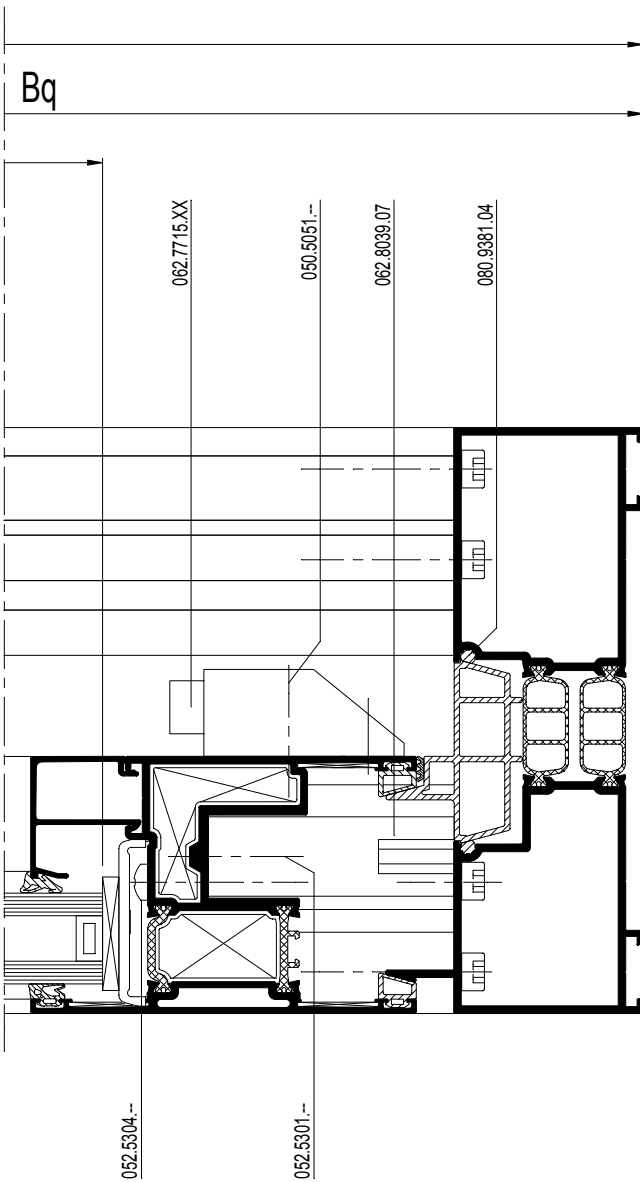

CP 155-LS

2-RAIL XQ
2-RAIL XQ
2-RAIL XQ
2-RAIL XQ

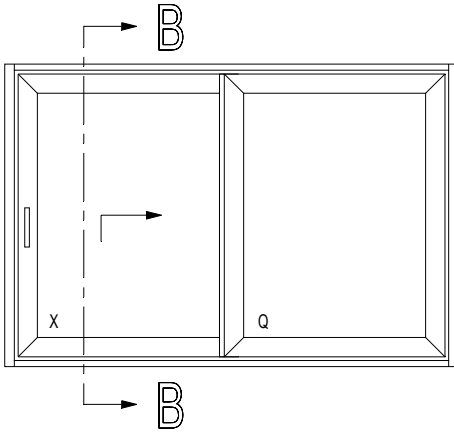

scale - Maßstab
1/2
D0013831

			#	L_m	
006.0317.XX			1	B-100	34.C....
006.0318.XX			1	B-100	34.C....
007.0767.01			1	B-100	34.C....
011.4631.--			1	B-100	34.C....
006.1302.XX			1	B-100	34.C....
006.1303.04			1	B-100	34.C....
006.1306.XX			2	H	34.C....
006.0305.04			2	H-75	34.C....
006.1340.XX			2	Bx-15.5	34.C....
			2	Bq-15.5	
			4	H-74	
006.1342.XX			2	H-74	34.C....
006.1341.04			2	H-74	34.C....
006.1343.00			1	H-131	34.C....
030.3614.XX			2	Bx-169.5	34.C....
			2	Bq-169.5	
			4	H-278	
(A) 0M0.1505.XX			1	Bx-678.5	34.C....
(B) 0M0.1505.XX			2	40	34.C....
			1	Bx-1334.5	34.C....



bx = Bx-181.5
hx = H-240
bq = Bq-181.5
hq = H-240

(*) Afhankelijk van de hoogte
 Dépend de l'hauteur
 Dependent of the height
 Von der Höhe abhängig

(A)	VLEUGELGEWICHT POIDS DU VANTAIL WEIGHT OF THE VENT FLÜGELGEWICHT	MAX. 300KG	(B)	VLEUGELGEWICHT POIDS DU VANTAIL WEIGHT OF THE VENT FLÜGELGEWICHT	MIN. 300KG MAX. 400KG
-----	---	------------	-----	---	--------------------------

		#	
052.5371.--		12	34.G....
068.7775.00		8	34.G....
069.6569.04		8	34.G....
060.8723.--		24	34.G....
062.7894.04		2	34.G....
052.5317.--		4	34.G....
071.6554.XX		4	34.G....
(A) 062.7867.--		1	34.G....
(B) 062.7867.--		1	34.G....
062.7903.--		1	34.G....
062.7902.ZC		1	34.G....
062.7868.ZC		1	34.G....
062.7864.XX		1	34.G....
061.7038.--		1	34.G....
(A) 062.7715.XX		1	34.G....
050.5051.--		1	34.G....
(B) 062.7715.XX		2	34.G....
050.5051.--		2	34.G....
062.6744.04		2	34.G....
053.5412.--		2	34.G....
062.8038.07		3	34.G....
052.5301.--		3	34.G....
062.8039.07		3	34.G....
052.5301.--		3	34.G....
052.5304.--		6	34.G....
062.8045.04		2	34.G....
062.8011.04		1	34.G....
062.8036.04		1	34.G....
053.5317.--		2	34.G....
052.5310.--		2xH (3/m)	34.G....
052.5317.--		H (3/m)	34.G....
062.9375.04		2	34.G....
(A) 069.8722.04		16 (-250KG)	34.G....
(A) 069.8722.04		12 (+250KG)	34.G....
069.8724.04		4	34.G....
(B) 069.8722.04		12	34.G....
069.8724.04		8	34.G....
069.6747.04		3	34.G....
080.9104.SY		(2xB)+(4xH)	34.G....
080.9114.SY		(2xB)+(4xH)	34.G....
080.9381.04		(2xB)+(4xH)	34.G....
080.9424.04		(4xB)+(4xH)	34.G....
081.9241.07		(2xH)	34.G....
080.9441.04		B	34.G....

HOOGTE HAUTEUR HEIGHT HOEHE	MIN. 1895 MM
--------------------------------------	--------------

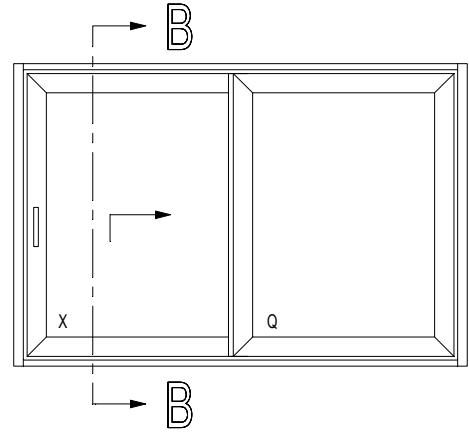

B - B

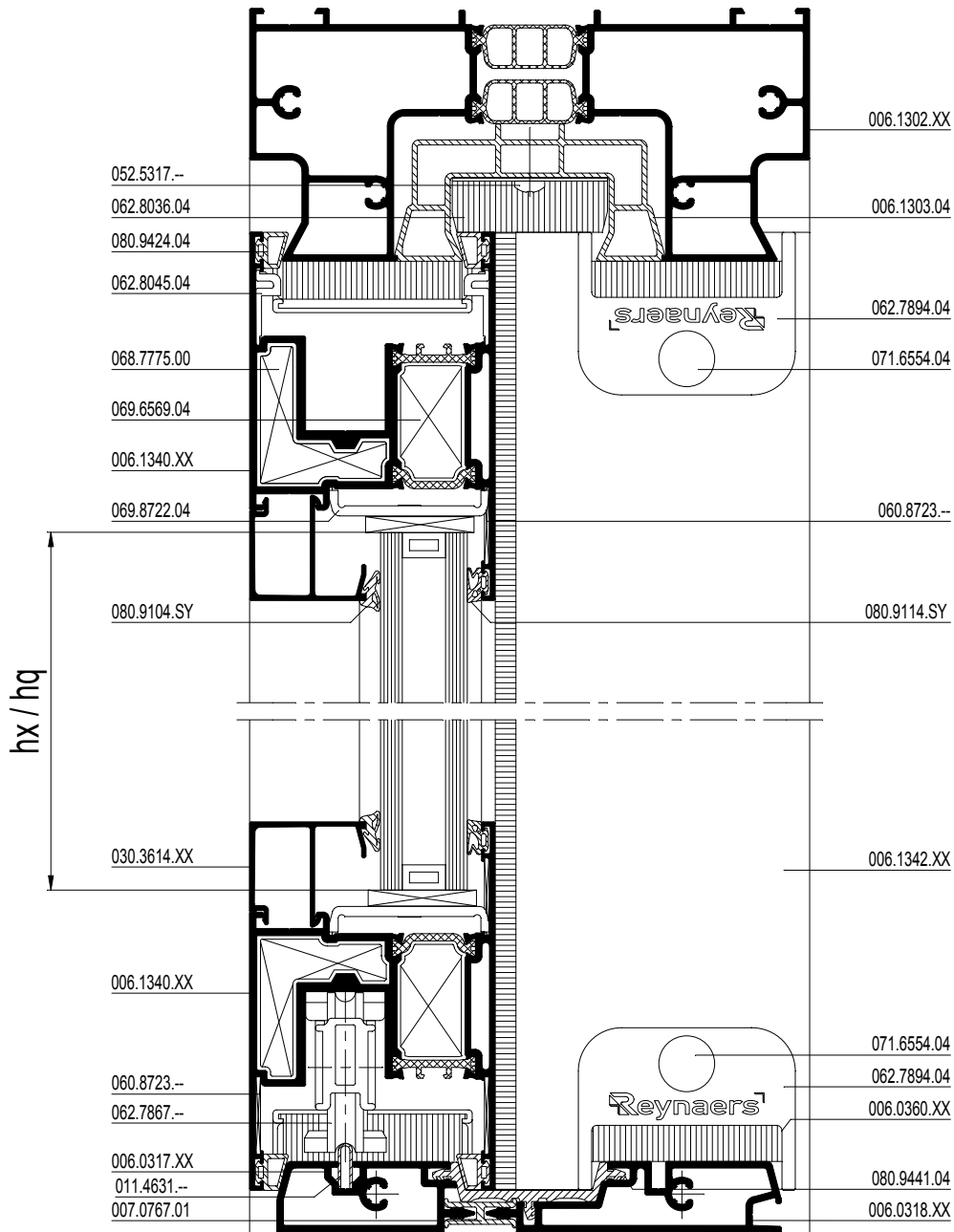

CP 155-LS

2-RAIL XX
 2-RAIL XX
 2-RAIL XX
 2-RAIL XX

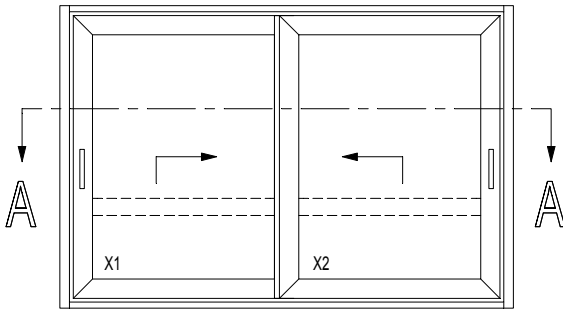

HOOGTE HAUTEUR HEIGHT HOEHE	MIN. 1895 MM
--------------------------------------	--------------

(A)	VLEUGELGEWICHT POIDS DU VANTAIL WEIGHT OF THE VENT FLÜGELGEWICHT	MAX. 300KG
-----	---	------------

(B)	VLEUGELGEWICHT POIDS DU VANTAIL WEIGHT OF THE VENT FLÜGELGEWICHT	MIN. 300KG MAX. 400KG
-----	---	--------------------------

A - A

B

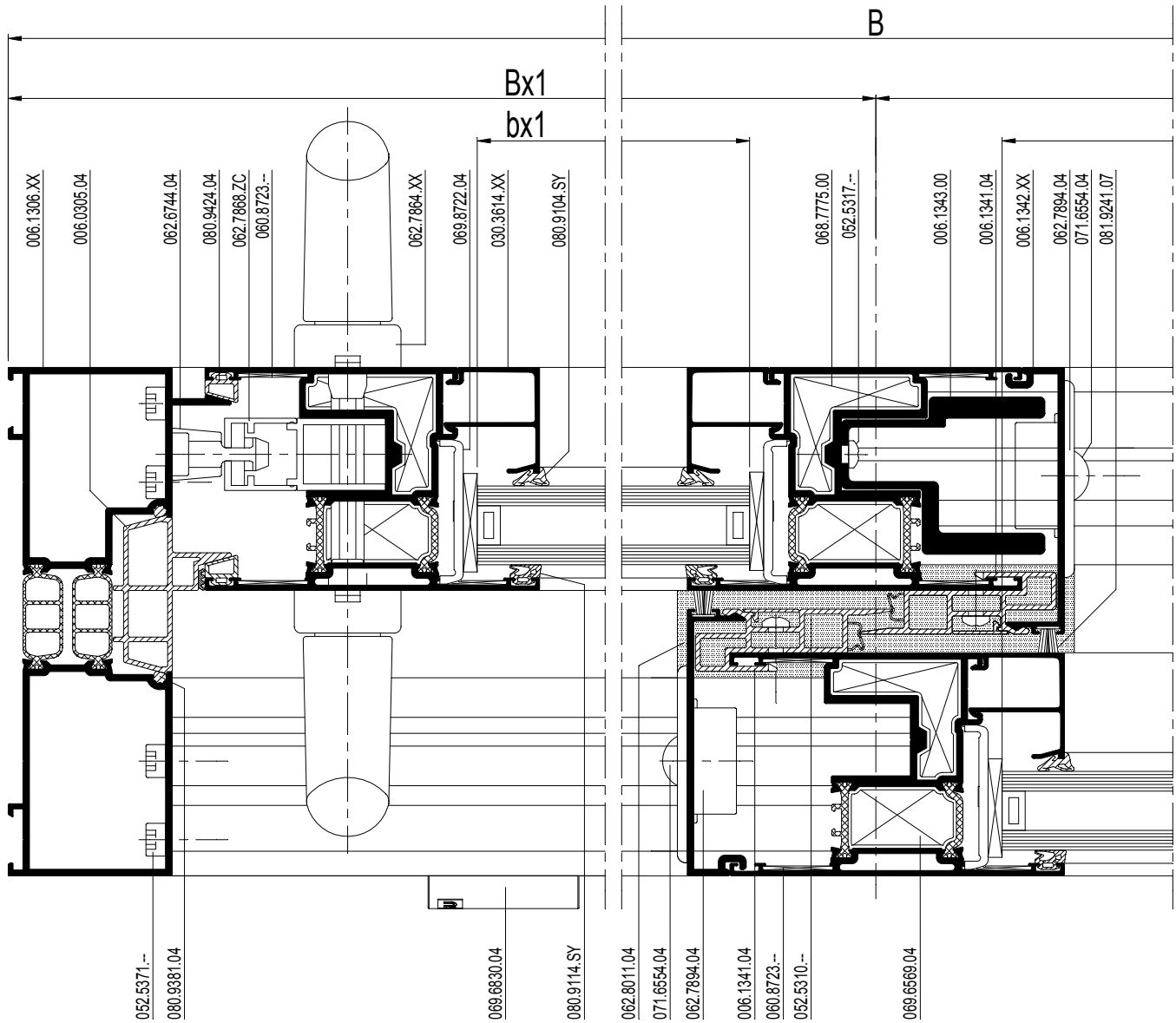

schaal - échelle
 scale - Maßstab
 1/2
 D001392

CP 155-LS

2-RAIL XX
 2-RAIL XX
 2-RAIL XX
 2-RAIL XX



		or		or	
	---	or	---	or	097.0436.00
	---	or	---	or	097.0437.00

		or	
	095.A700.00	or	095.B300.00
	095.A730.00		095.B323.00

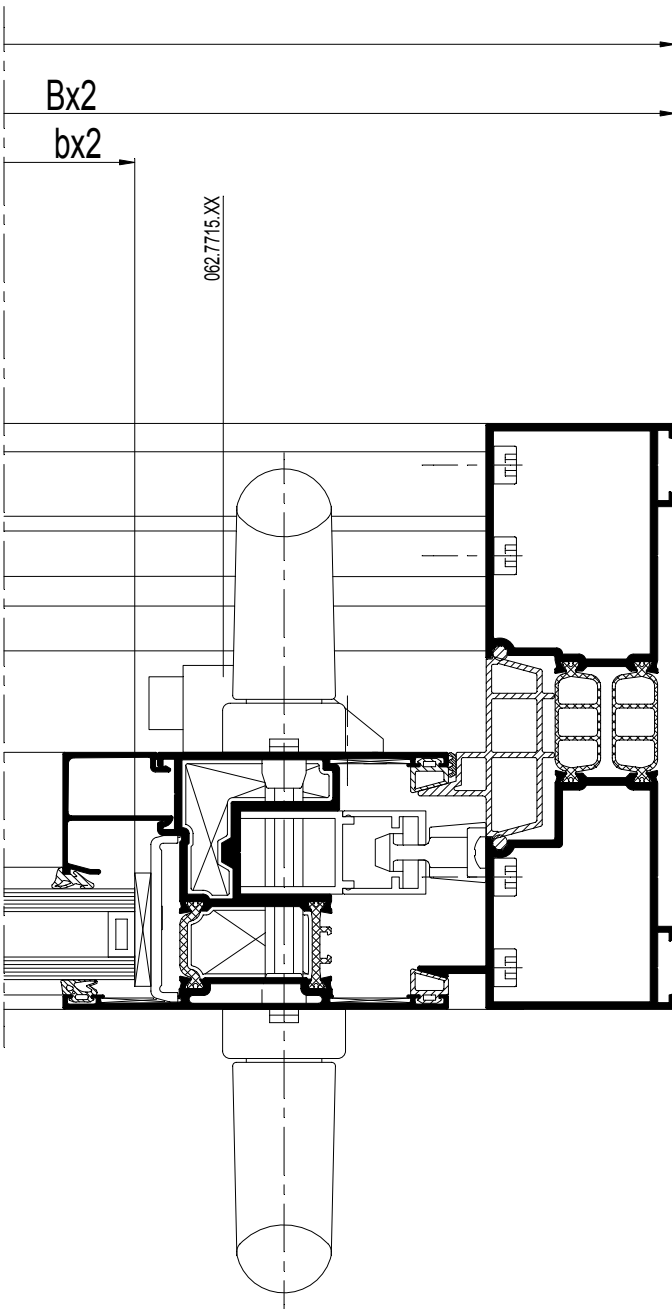

schaal - échelle
 scale - Maßstab
 1/2

D0013832

CP 155-LS

2-RAIL XX
2-RAIL XX
2-RAIL XX
2-RAIL XX

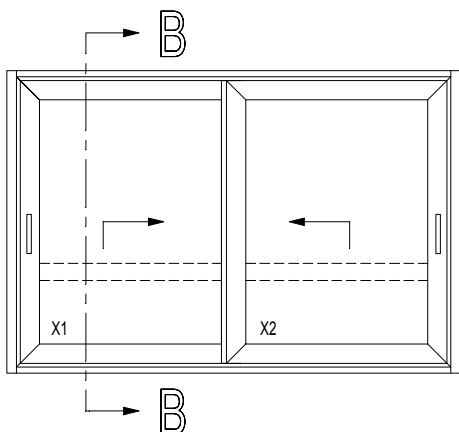

HOOGTE HAUTEUR HEIGHT HOEHE	MIN. 1895 MM
--------------------------------------	--------------

(A)	VLEUGELGEWICHT POIDS DU VANTAIL WEIGHT OF THE VENT FLÜGELGEWICHT	MAX. 300KG
-----	---	------------

(B)	VLEUGELGEWICHT POIDS DU VANTAIL WEIGHT OF THE VENT FLÜGELGEWICHT	MIN. 300KG MAX. 400KG
-----	---	--------------------------

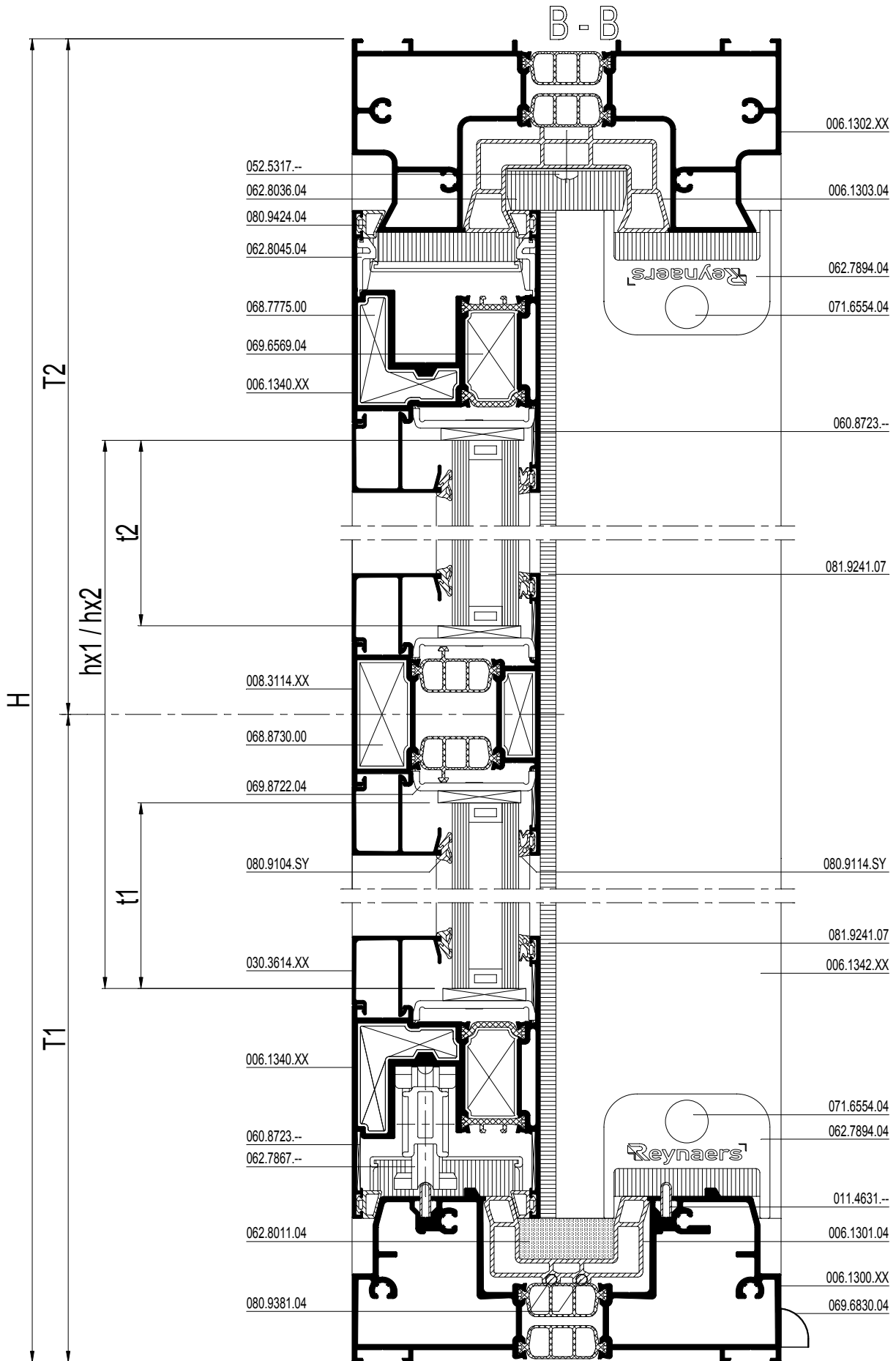

schaal - échelle
 scale - Maßstab
 1/2

D0013933

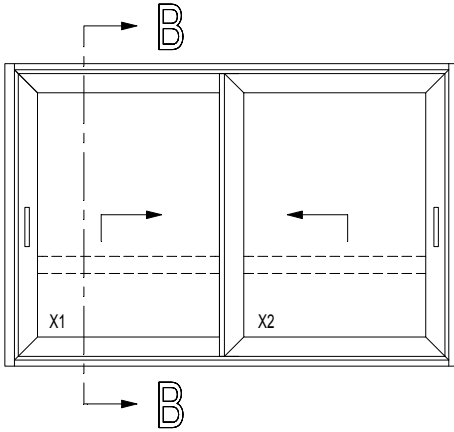

			#	$\leftarrow L_m \rightarrow$	
006.1300.XX 006.1301.04			1	B-100	34.C....
011.4631.--			2	B-100	34.C....
006.1302.XX			1	B-100	34.C....
006.1303.04			1	B-100	34.C....
006.1306.XX			2	H	34.C....
006.0305.04			2	H - 150	34.C....
006.1340.XX			2	B-15.5	34.C....
			2	B-15.5	
			4	H-114	
006.1342.XX			2	H-114	34.C....
006.1341.04			2	H-114	34.C....
006.1343.00			1	H-171	34.C....
030.3614.XX			2	Bx1-169.5	34.C....
			2	Bx2-169.5	
			4	H-318	
(A) 0M0.1505.XX			1	Bx1-678.5	34.C....
			1	Bx2-678.5	
(B) 0M0.1505.XX			4	40	34.C....
			1	Bx1-1334.5	
			1	Bx2-1334.5	

met dwarsstijl
avec traverse
with transom
mit Sprossenprofil
+

008.3114.XX			1	Bx1-169.5	34.C....
			1	Bx2-169.5	

(A)	VLEUGELGEWICHT POIDS DU VANTAIL WEIGHT OF THE VENT FLÜGELGEWICHT	MAX. 300KG	(B)	VLEUGELGEWICHT POIDS DU VANTAIL WEIGHT OF THE VENT FLÜGELGEWICHT	MIN. 300KG MAX. 400KG
-----	---	------------	-----	---	--------------------------

HOOGTE HAUTEUR HEIGHT HOEHE	MIN. 1895 MM
--------------------------------------	--------------

bx1 = Bx1-181.5
hx1 = H-280
bx2 = Bx2-181.5
hx2 = H-280

met dwarsstijl
avec traverse
with transom
mit Sprossenprofil

t1 = T1-167
t2 = T2-177

			#	
	052.5371.--		16	34.G...
	062.9396.--		2	34.G...
	068.7775.00		8	34.G...
	069.6569.04		8	34.G...
	060.8723.--		24	34.G...
	062.7894.04		2	34.G...
	052.5317.--		4	34.G...
	071.6554.XX		4	34.G...
(A)	062.7867.--		2	34.G...
(B)	062.7867.--		2	34.G...
	062.7903.--		2	34.G...
(*)	062.7902.ZC <small>OF-OU-OR-ODER</small>		2	34.G...
	062.7868.ZC		2	34.G...
	062.7864.XX		2	34.G...
	061.7038.--		2	34.G...
(A)	062.7715.XX		1	34.G...
	050.5051.--		1	34.G...
(B)	062.7715.XX		2	34.G...
	050.5051.--		2	34.G...
	062.6744.04		4	34.G...
	053.5412.--		4	34.G...
	062.8045.04		4	34.G...
	062.8011.04		1	34.G...
	062.8036.04		1	34.G...
	052.5317.--		2	34.G...
	052.5310.--		2xH (3/m)	34.G...
	052.5317.--		H (3/m)	34.G...
	062.9375.04		2	34.G...
(A)	069.8722.04		16 (-250KG)	34.G...
(A)	069.8722.04		12 (+250KG)	34.G...
	069.8724.04		4	34.G...
(B)	069.8722.04		12	34.G...
	069.8724.04		8	34.G...
	062.6857.04		2	34.G...
	069.6830.04		min. 2	34.G...
	080.9104.SY		(2xB)+(4xH)	34.G...
	080.9114.SY		(2xB)+(4xH)	34.G...
	080.9381.04		(2xB)+(4xH)	34.G...
	080.9424.04		(4xB)+(4xH)	34.G...
	081.9241.07		2xH	34.G...
met dwarsstijl avec traverse with transom mit Sprossenprofil +				
	068.8732.00		4	34.G...
	050.5153.--		8	34.G...
	069.8722.04		16	34.G...
	080.9104.SY		2xB	34.G...
	080.9114.SY		2xB	34.G...

(*) Afhankelijk van de hoogte
Dépend de l'hauteur
Dependent of the height
Von der Höhe abhängig

CP 155-LS

2-RAIL XQX
 2-RAIL XQX
 2-RAIL XQX
 2-RAIL XQX

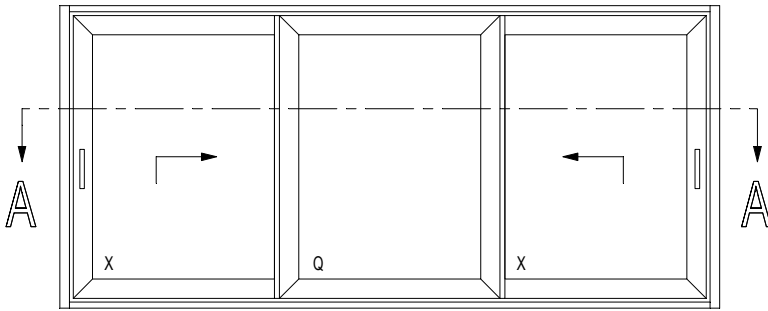

(A)	VLEUGELGEWICHT POIDS DU VANTAIL WEIGHT OF THE VENT FLÜGELGEWICHT	MAX. 300KG
(B)	VLEUGELGEWICHT POIDS DU VANTAIL WEIGHT OF THE VENT FLÜGELGEWICHT	MIN. 300KG MAX. 400KG
	HOOGTE HAUTEUR HEIGHT HOEHE	MIN. 1895 MM

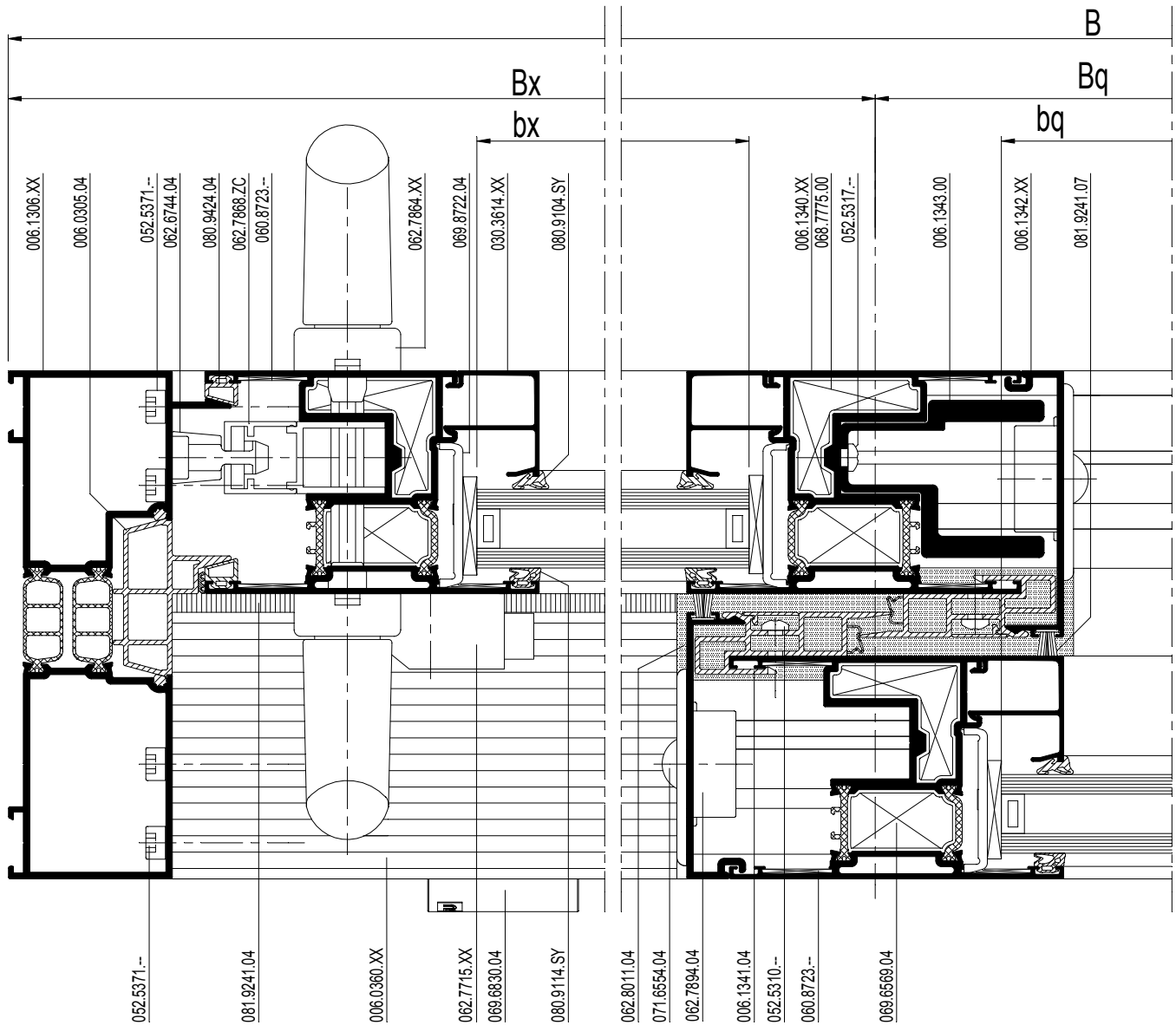

schaal - échelle
 scale - Maßstab
 1/2
 D0013934

		or		or	
	---	or	---	or	097.0436.00
	---	or	---	or	097.0437.00

		or	
	095.A700.00	or	095.B300.00
	095.A730.00		095.B323.00

A - A

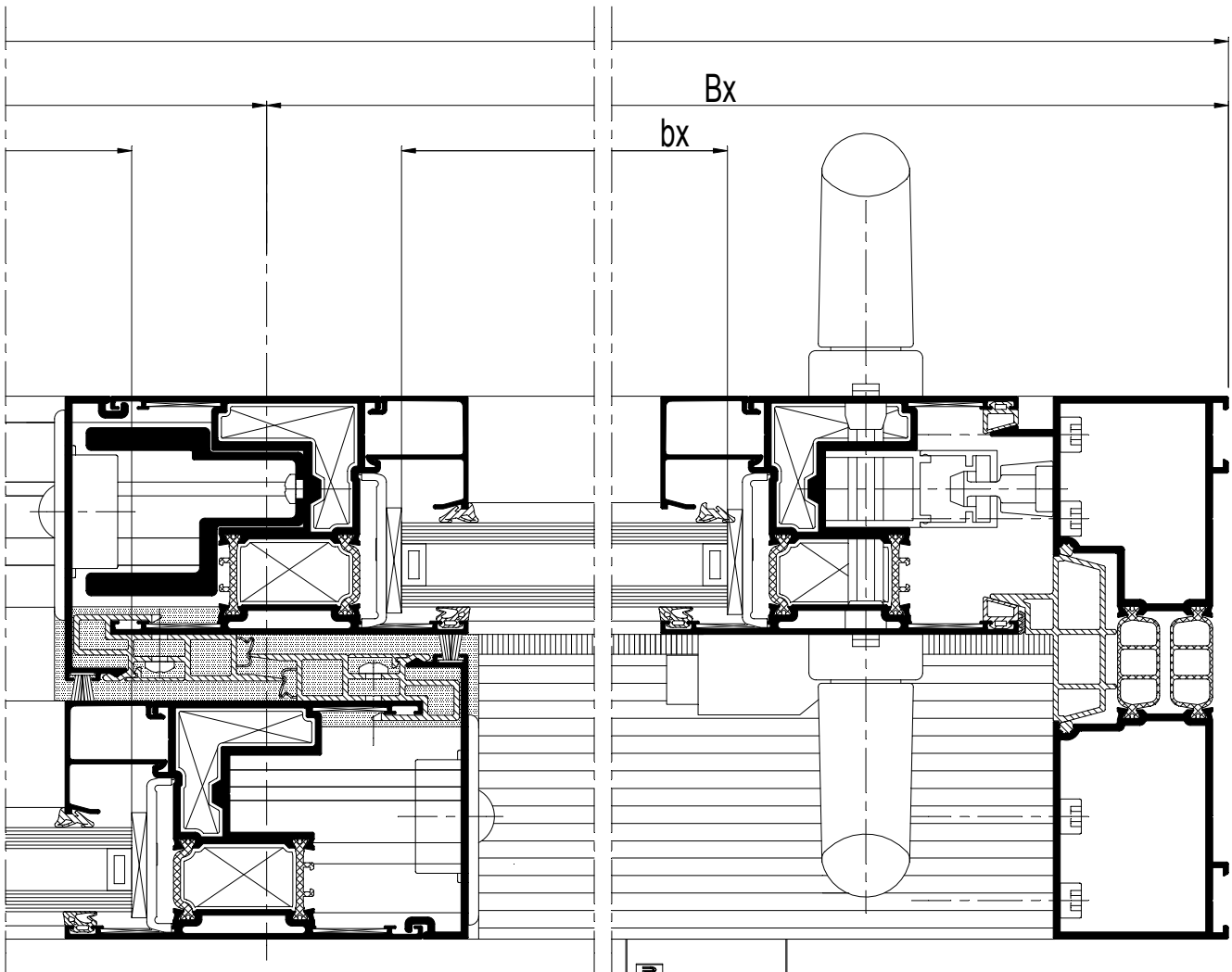

schaal - échelle
 scale - Maßstab
 1/2

D0013934

CP 155-LS

2-RAIL XQX
2-RAIL XQX
2-RAIL XQX
2-RAIL XQX

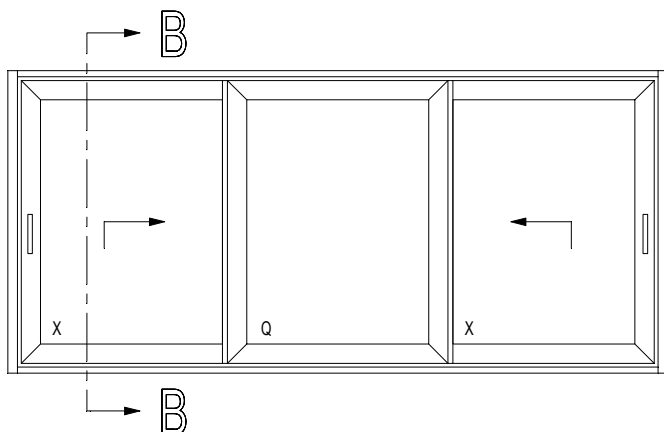

(A)	VLEUGELGEWICHT	MAX. 300KG
	POIDS DU VANTAIL	
	WEIGHT OF THE VENT	
	FLÜGELGEWICHT	

(B)	VLEUGELGEWICHT	MIN. 300KG MAX. 400KG
	POIDS DU VANTAIL	
	WEIGHT OF THE VENT	
	FLÜGELGEWICHT	

HOOGTE HAUTEUR HEIGHT HOEHE	MIN. 1895 MM
--------------------------------------	--------------

B - B

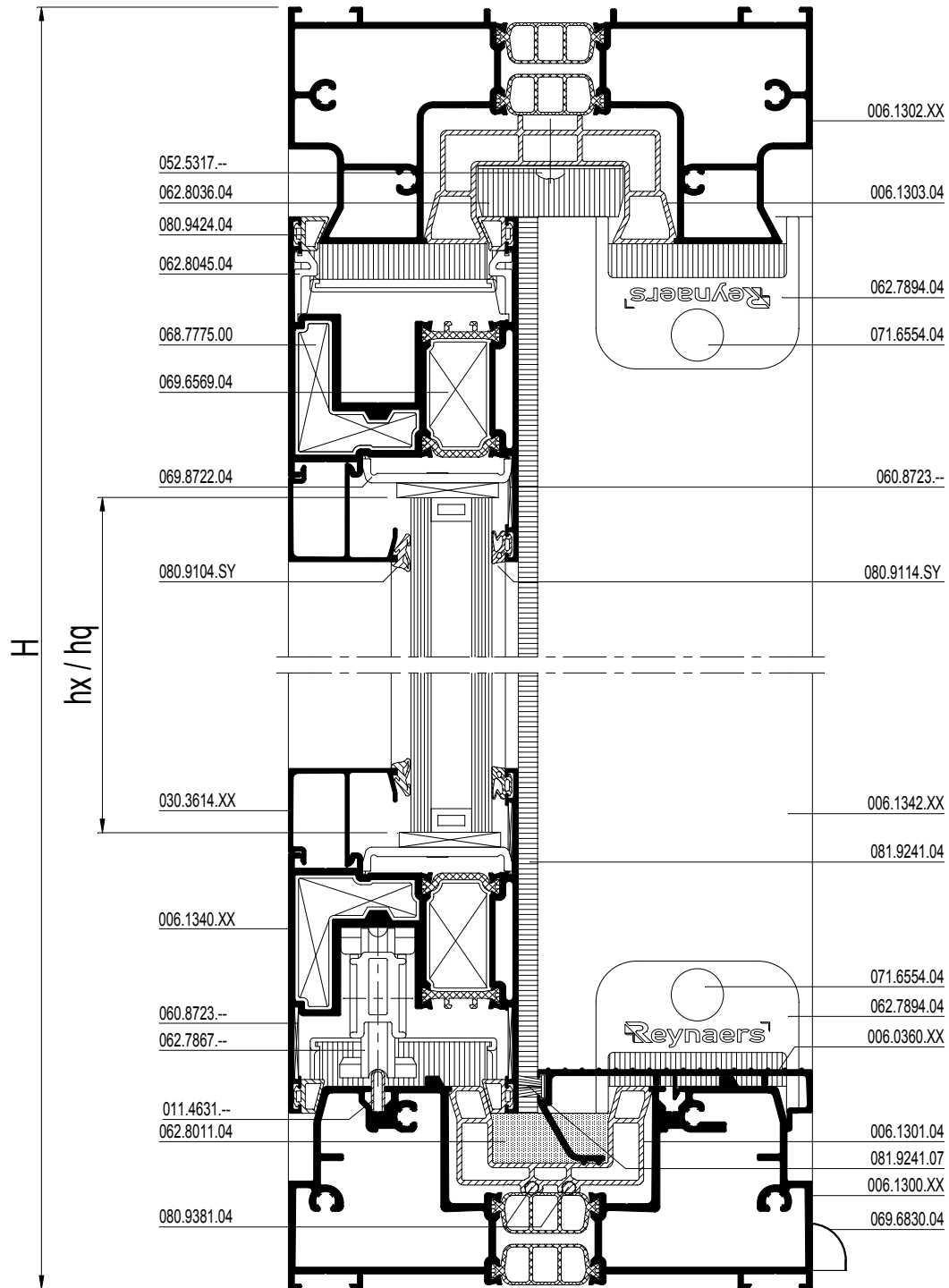





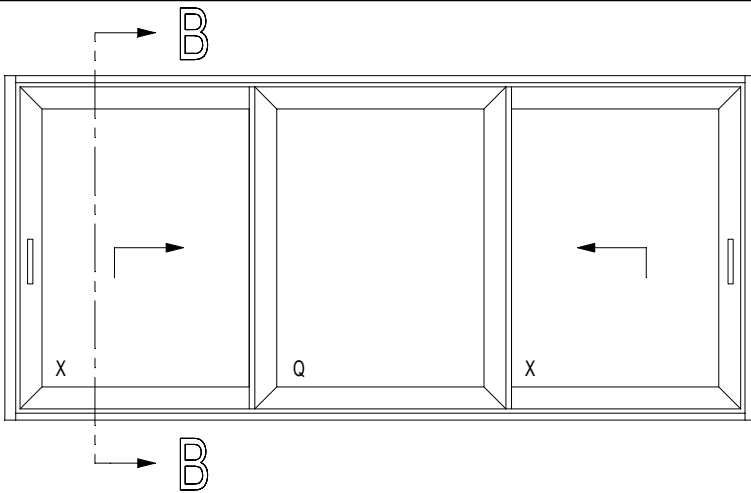





























schaal - échelle
 scale - Maßstab
 1/2

D0013935



(A)	VLEUGELGEWICHT POIDS DU VANTAIL WEIGHT OF THE VENT FLÜGELGEWICHT	MAX. 300KG
-----	---	------------

(B)	VLEUGELGEWICHT POIDS DU VANTAIL WEIGHT OF THE VENT FLÜGELGEWICHT	MIN. 300KG MAX. 400KG
-----	---	--------------------------

			#	$\leftarrow L_m \rightarrow$	
006.1300.XX 006.1301.04			1	B-100	34.C....
011.4631.--			1	B-100	34.C....
006.1302.XX			1	B-100	34.C....
006.1303.04			1	B-100	34.C....
006.1306.XX			2	H	34.C....
006.0305.04			2	H - 150	34.C....
006.1340.XX			4	Bx-15.5	34.C....
			2	Bq+89	
			6	H-114	
006.1342.XX			4	H-114	34.C....
006.1341.04			4	H-114	34.C....
006.1343.00			2	H-171	34.C....
030.3614.XX			4	Bx-169.5	34.C....
			2	Bq-65	
			6	H-318	
006.0360.XX			2	Bx-110.5	34.C....
(A) 0M0.1505.XX			2	Bx-678.5	34.C....
(B) 0M0.1505.XX			4	40	34.C....
			2	Bx-1334.5	

HOOGTE HAUTEUR HEIGHT HOEHE	MIN. 1895 MM
--------------------------------------	--------------

bx = Bx-181.5
hx = H-280
bq = Bq-70
hq = H-280

			#	
			16	34.G...
			2	34.G...
			12	34.G...
			12	34.G...
			36	34.G...
			4	34.G...
			8	34.G...
			8	34.G...
(A)			2	34.G...
(B)			2	34.G...
			2	34.G...
(*)			2	34.G...
			2	34.G...
			2	34.G...
(A)			2	34.G...
			2	34.G...
(B)			4	34.G...
			4	34.G...
			4	34.G...
			4	34.G...
			4	34.G...
			4	34.G...
			2	34.G...
			2	34.G...
			4	34.G...
			4xH (3/m)	34.G...
			2xH (3/m)	34.G...
			1	34.G...
			1	34.G...
(A)			24 (-250KG)	34.G...
(A)			18 (+250KG)	34.G...
			6	34.G...
(B)			18	34.G...
			12	34.G...
			2	34.G...
			min. 2	34.G...
			(2xB)+(6xH)	34.G...
			(2xB)+(6xH)	34.G...
			(2xB)+(4xH)	34.G...
			(4xB)+(4xH)	34.G...
			(4xH)+(2xBx)	34.G...
			3	34.G...
			3	34.G...
			3	34.G...

(*) Afhankelijk van de hoogte
Dépend de l'hauteur
Dependent of the height
Von der Höhe abhängig

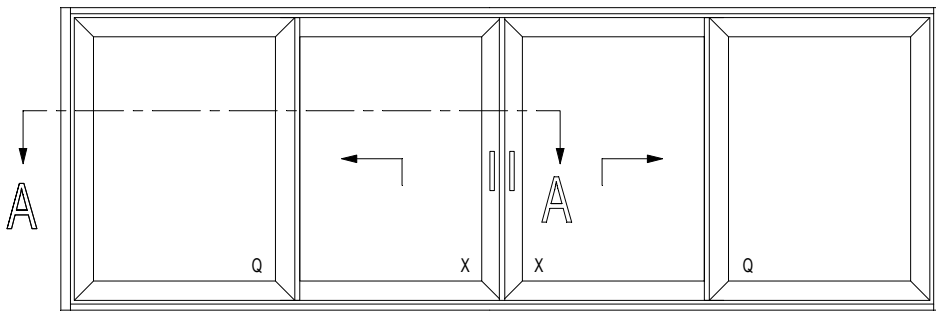

(A)	VLEUGELGEWICHT POIDS DU VANTAIL WEIGHT OF THE VENT FLÜGELGEWICHT	MAX. 300KG
(B)	VLEUGELGEWICHT POIDS DU VANTAIL WEIGHT OF THE VENT FLÜGELGEWICHT	MIN. 300KG MAX. 400KG
	HOOGTE HAUTEUR HEIGHT HOEHE	MIN. 1895 MM

A - A

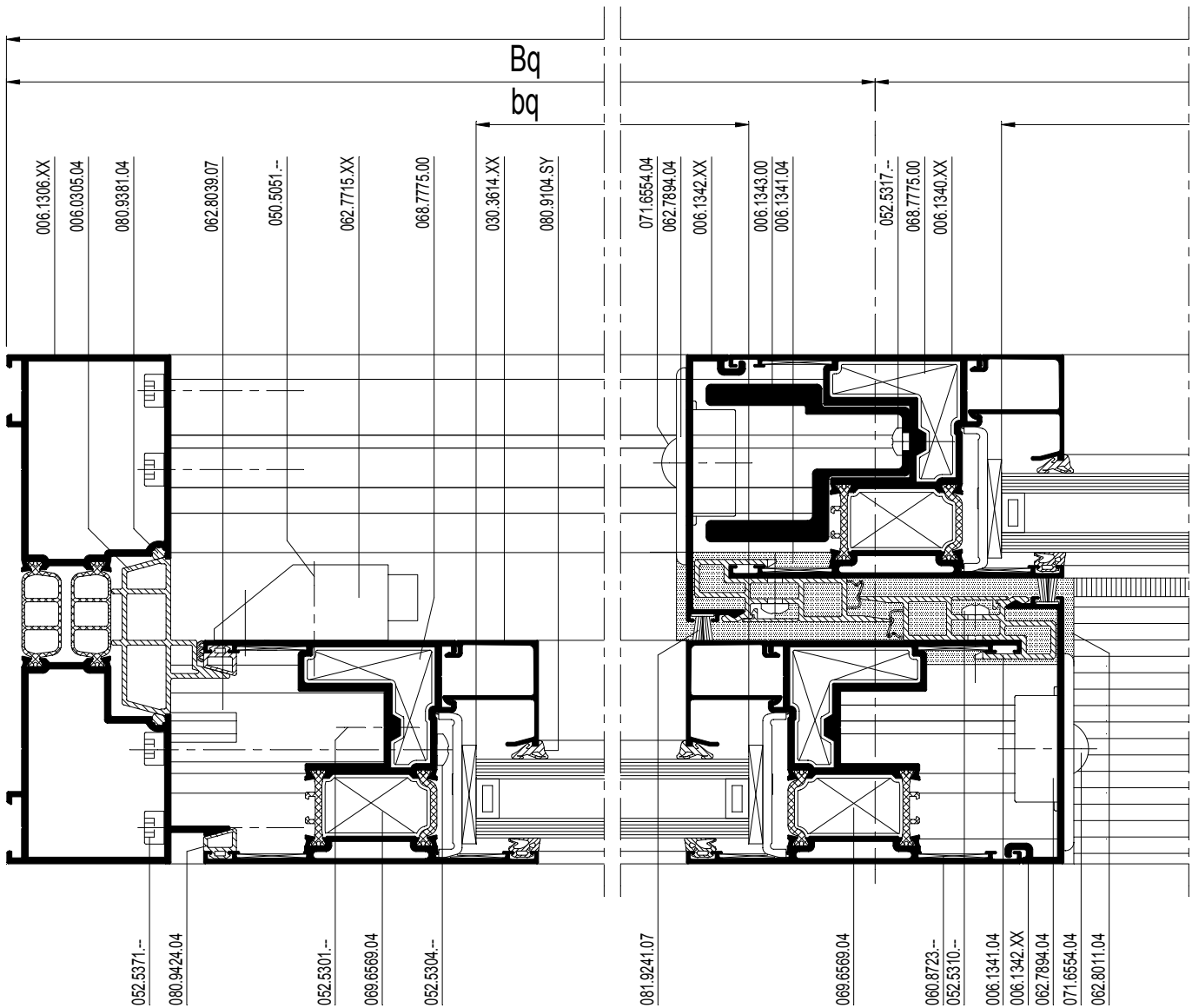

schaal - échelle
 scale - Maßstab
 1/2
 D0013936

CP 155-LS

2-RAIL OXXQ
 2-RAIL OXXQ
 2-RAIL OXXQ
 2-RAIL OXXQ



		or		or	
	---	or	---	or	097.0436.00
	---	or	---	or	097.0437.00

		or	
	095.A700.00	or	095.B300.00
	095.A730.00		095.B323.00

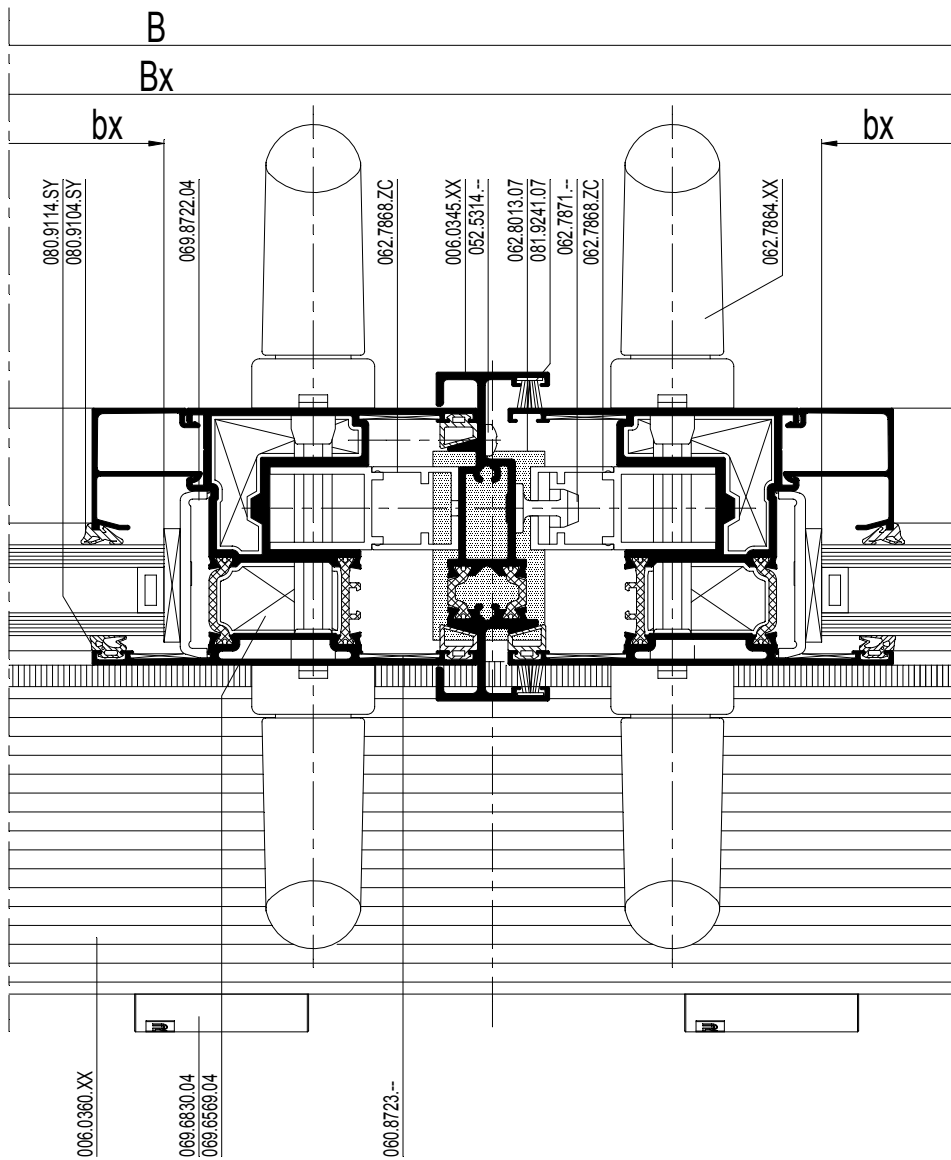

schaal - échelle
 scale - Maßstab
 1/2

D0013936

CP 155-LS

2-RAIL QXXQ
 2-RAIL QXXQ
 2-RAIL QXXQ
 2-RAIL QXXQ

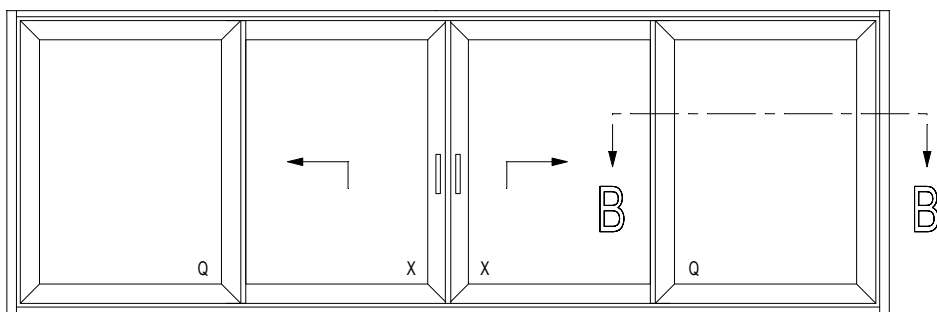

(A)	VLEUGELGEWICHT POIDS DU VANTAIL WEIGHT OF THE VENT FLÜGELGEWICHT	MAX. 300KG
-----	---	------------





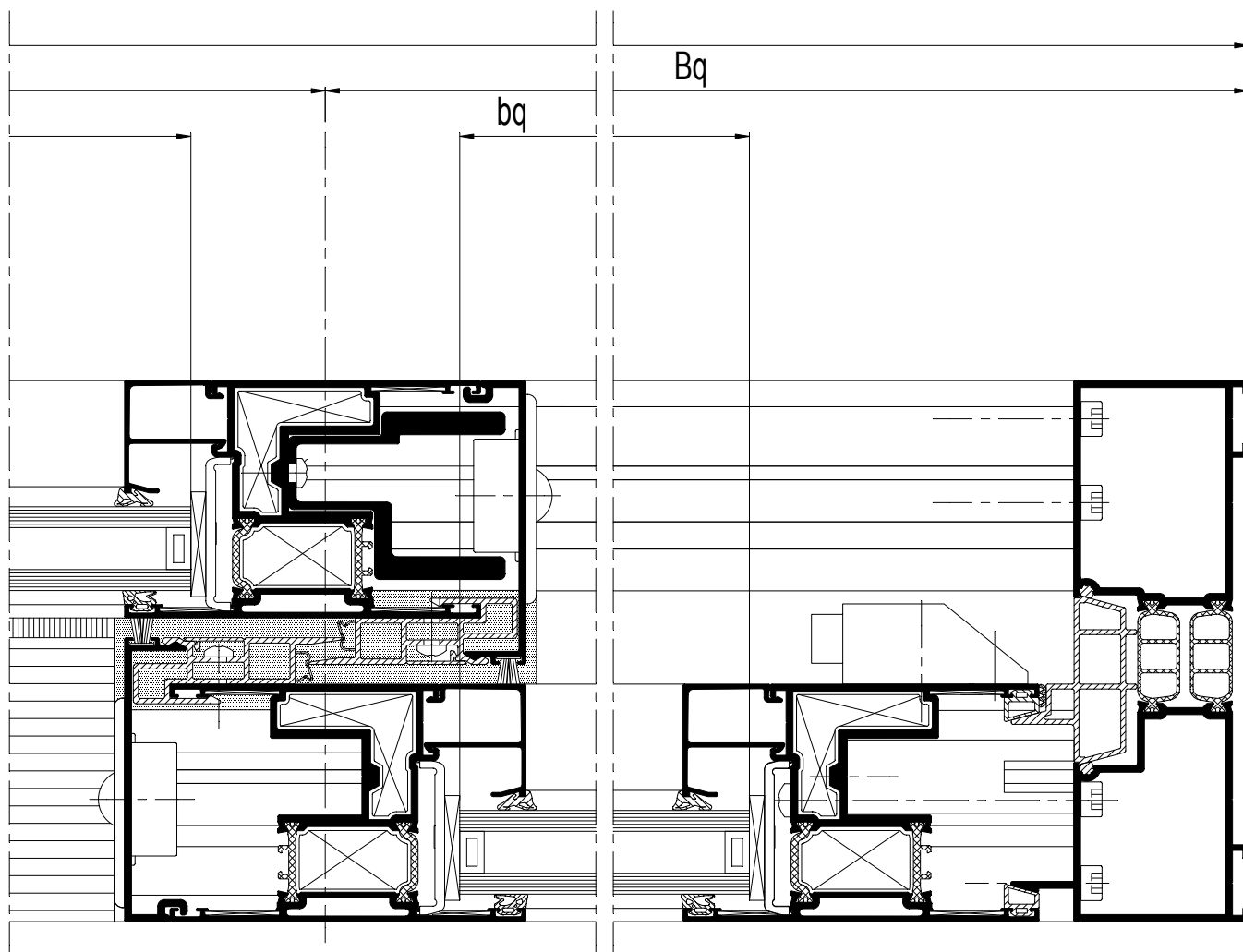





(B)	VLEUGELGEWICHT POIDS DU VANTAIL WEIGHT OF THE VENT FLÜGELGEWICHT	MIN. 300KG MAX. 400KG
-----	---	--------------------------













































	HOOGTE HAUTEUR HEIGHT HOEHE	MIN. 1895 MM
--	--------------------------------------	--------------



schaal - échelle
 scale - Maßstab
 1/2

D0013937

		#	
062.6857.04		2	34.G...
069.6830.04		min. 2	34.G...
080.9104.SY		(2xB)+(8xH)	34.G...
080.9114.SY		(2xB)+(8xH)	34.G...
080.9381.04		(2xB)+(4xH)	34.G...
080.9424.04		(4xB)+(7xH)	34.G...
081.9241.07		(6xH)+Bx	34.G...

		#	
052.5371.--		16	34.G...
062.9396.--		2	34.G...
068.7775.00		16	34.G...
069.6569.04		16	34.G...
060.8723.--		48	34.G...
062.7894.04		4	34.G...
052.5317.--		8	34.G...
071.6554.XX		8	34.G...
(A) 062.7867.--		2	34.G...
(B) 062.7867.--		2	34.G...
(B) 062.7903.--		2	34.G...
(*) 062.7902.ZC		2	34.G...
(*) 062.7868.ZC		2	34.G...
062.7871.--		1	34.G...
062.7864.XX		2	34.G...
061.7038.--		2	34.G...
(A) 062.7715.XX		2	34.G...
(B) 050.5051.--		2	34.G...
(B) 062.7715.XX		4	34.G...
(B) 050.5051.--		4	34.G...
062.7717.04		2	34.G...
062.8038.07		6	34.G...
052.5301.--		6	34.G...
062.8039.07		6	34.G...
052.5301.--		6	34.G...
052.5304.--		12	34.G...
062.8045.04		4	34.G...
062.8011.04		2	34.G...
062.8013.07		1	34.G...
052.5317.--		4	34.G...
062.8036.04		2	34.G...
052.5317.--		4	34.G...
052.5310.--		4xH (3/m)	34.G...
052.5317.--		2xH (3/m)	34.G...
052.5314.--		H (3/m)	34.G...
062.9372.04		1	34.G...
062.9375.04		1	34.G...
(A) 069.8722.04		32 (-250KG)	34.G...
(A) 069.8722.04		24 (+250KG)	34.G...
(A) 069.8724.04		8	34.G...
(B) 069.8722.04		24	34.G...
(B) 069.8724.04		16	34.G...

(*) Afhankelijk van de hoogte
Dépend de l'hauteur
Dependent of the height
Von der Höhe abhängig

CP 155-LS

2-RAIL QXXQ
 2-RAIL QXXQ
 2-RAIL QXXQ
 2-RAIL QXXQ

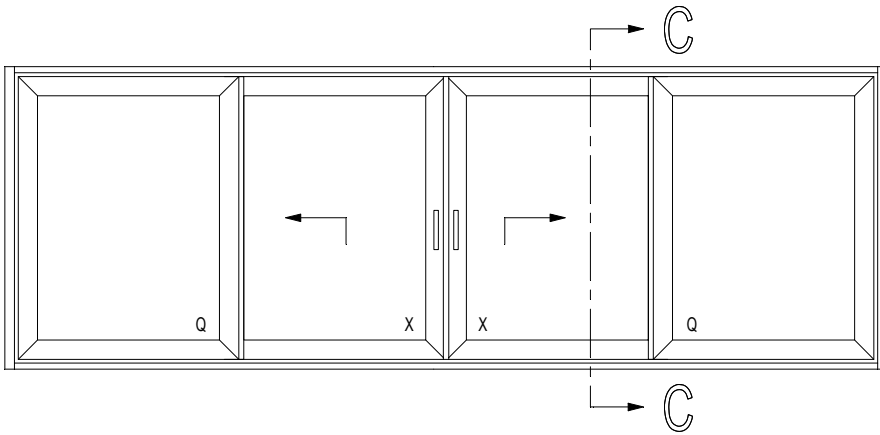

(A)	VLEUGELGEWICHT POIDS DU VANTAIL WEIGHT OF THE VENT FLÜGELGEWICHT	MAX. 300KG
(B)	VLEUGELGEWICHT POIDS DU VANTAIL WEIGHT OF THE VENT FLÜGELGEWICHT	MIN. 300KG MAX. 400KG
	HOOGTE HAUTEUR HEIGHT HOEHE	MIN. 1895 MM

			#	$\leftarrow L_m \rightarrow$	
006.1300.XX 006.1301.04			1	B-100	34.C....
011.4631.--			1	B-100	34.C....
006.1302.XX			1	B-100	34.C....
006.1303.04			1	B-100	34.C....
006.1306.XX			2	H	34.C....
006.0305.04			2	H - 150	34.C....
006.1340.XX			4	$(Bx:2)+40.5$	34.C....
			4	Bq-15.5	
			8	H-114	
006.1342.XX			4	H-114	34.C....
006.1341.04			4	H-114	34.C....
006.1343.00			2	H-171	34.C....
006.0345.XX			1	H-114	34.C....
030.3614.XX			4	$(Bx:2)-113.5$	34.C....
			4	Bq-169.5	
			8	H-318	
006.0360.XX			1	Bx-121	34.C....
(A) 0M0.1505.XX			2	$(Bx:2)-622.5$	34.C....
(B) 0M0.1505.XX			4	40	34.C....
			2	Bx1-1334.5	

$bx = (Bx:2)-125.5$
$hx = H-280$
$bq = Bq-181.5$
$hq = H-280$

C - C

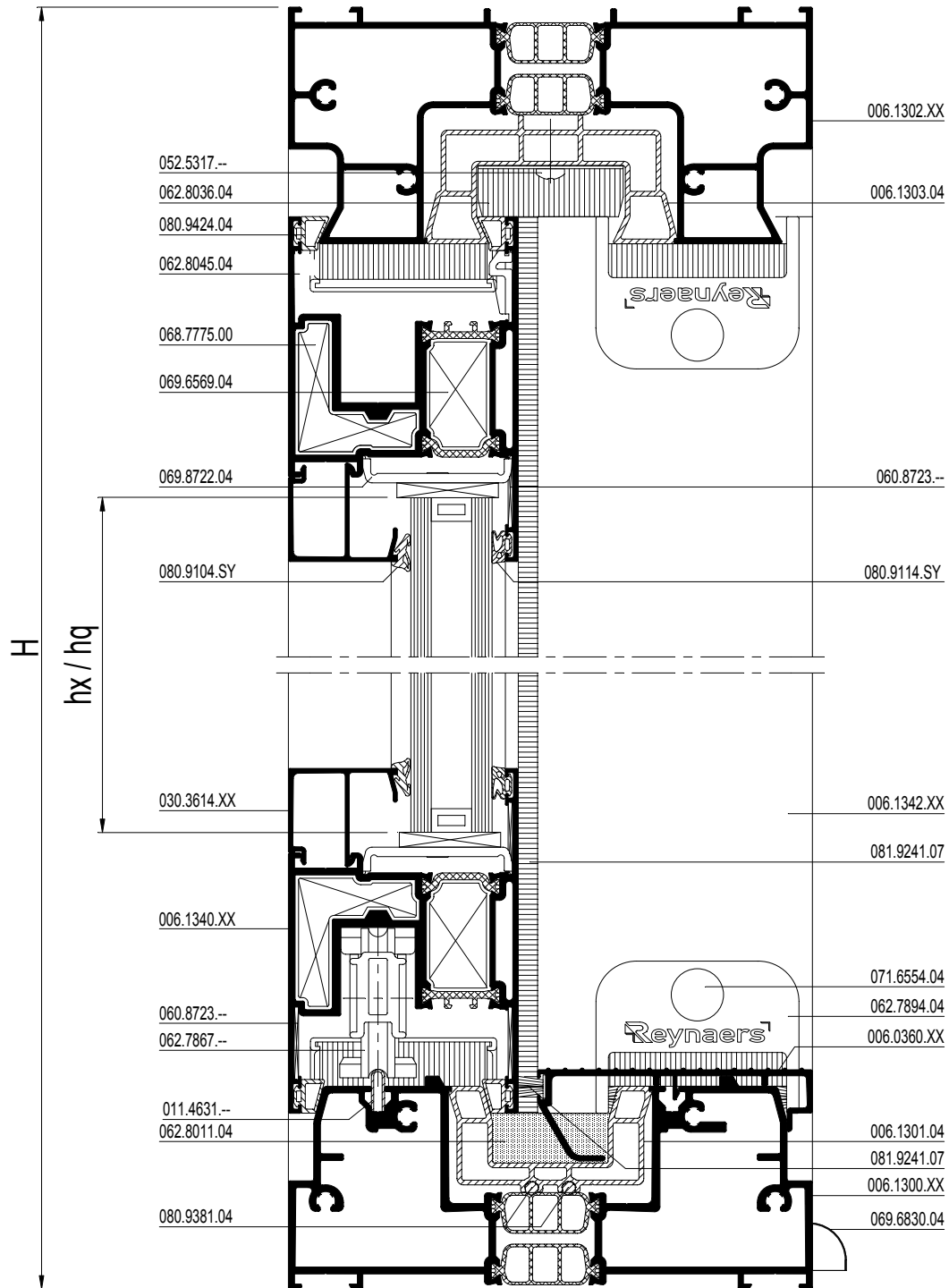

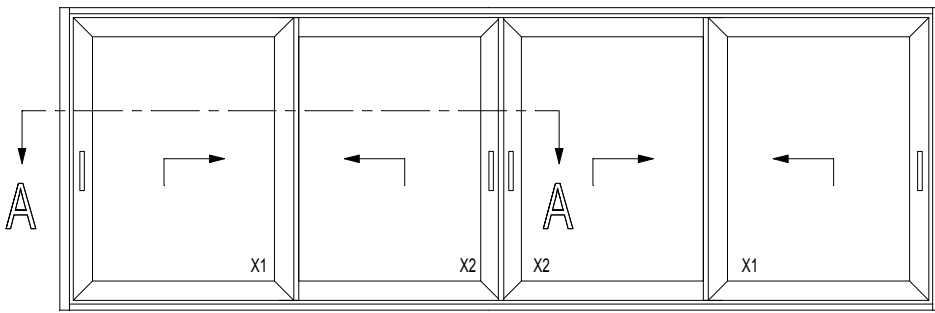

(A)	VLEUGELGEWICHT POIDS DU VANTAIL WEIGHT OF THE VENT FLÜGELGEWICHT	MAX. 300KG
(B)	VLEUGELGEWICHT POIDS DU VANTAIL WEIGHT OF THE VENT FLÜGELGEWICHT	MIN. 300KG MAX. 400KG
	HOOGTE HAUTEUR HEIGHT HOEHE	MIN. 1895 MM

A - A

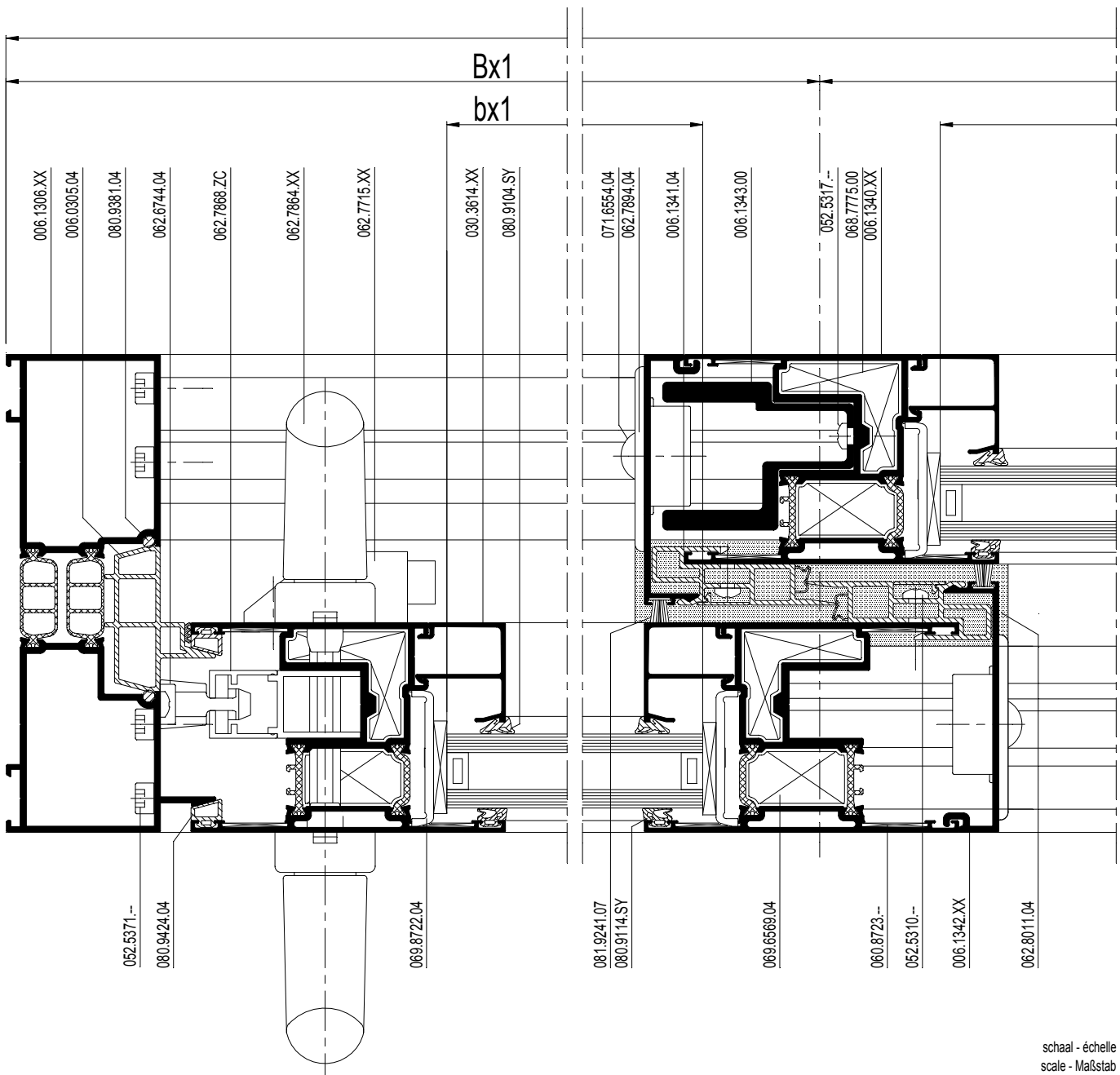

schaal - échelle
 scale - Maßstab
 1/2
 D0013939

		or		or	
	---	or	---	or	097.0436.00
	---	or	---	or	097.0437.00

		or	
	095.A700.00	or	095.B300.00
	095.A730.00		095.B323.00

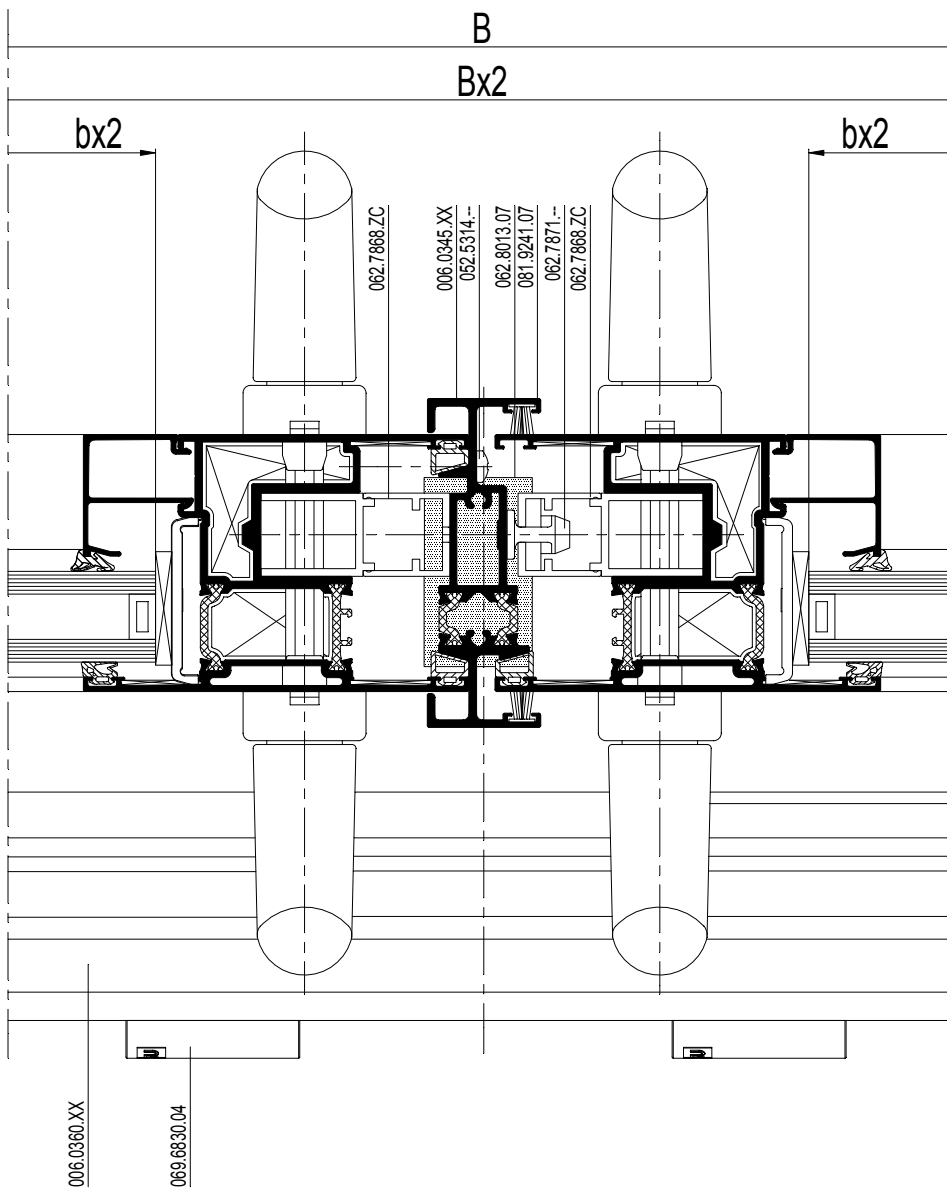

schaal - échelle
 scale - Maßstab
 1/2

D0013839

CP 155-LS

2-RAIL XXXX
 2-RAIL XXXX
 2-RAIL XXXX
 2-RAIL XXXX

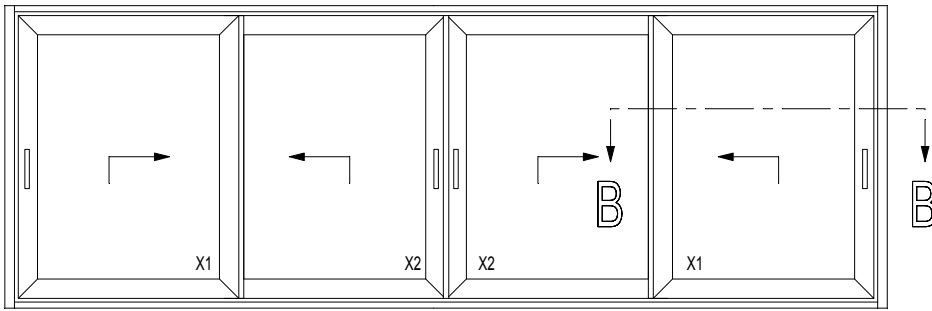





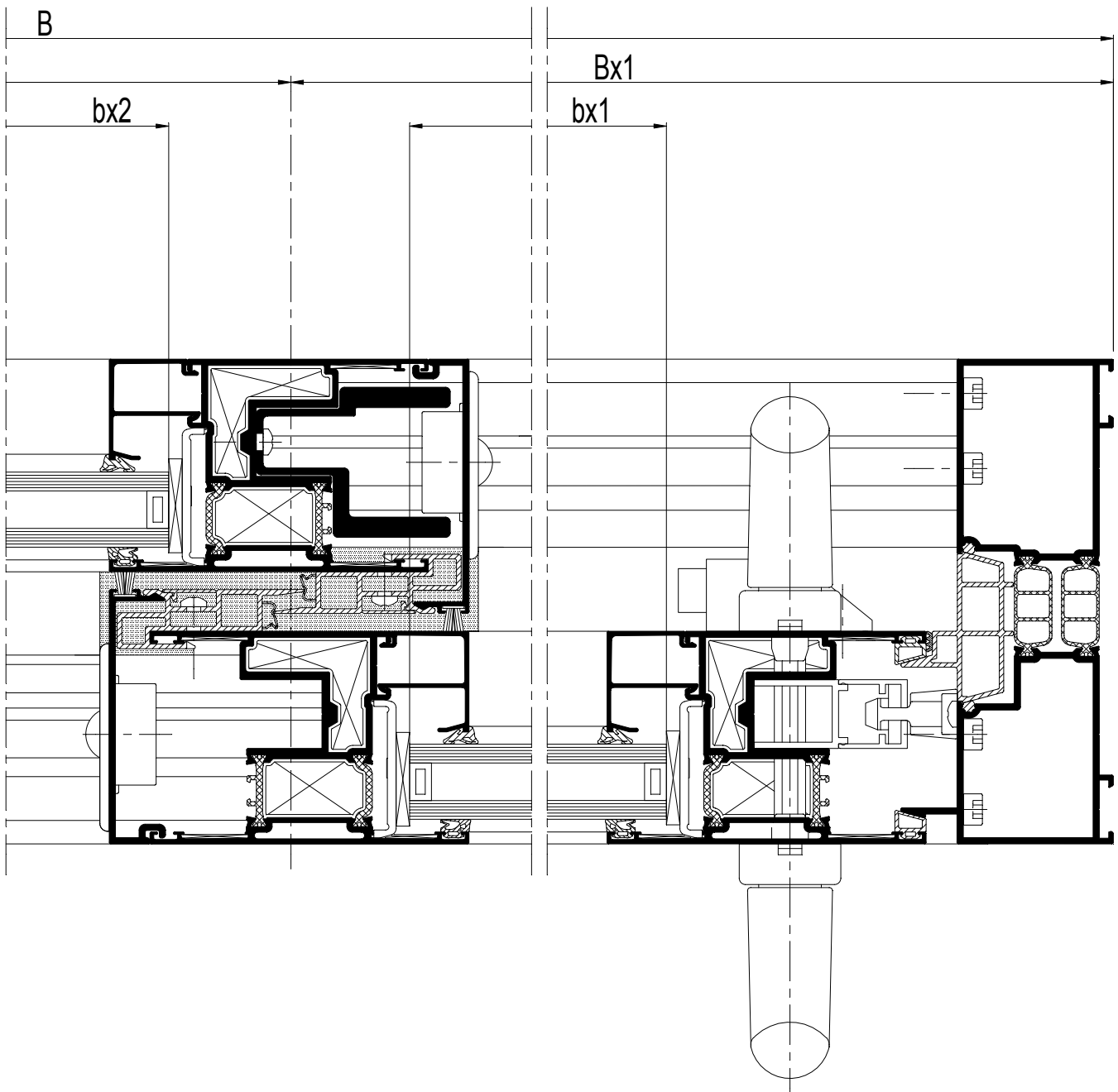









































B - B

(A)	VLEUGELGEWICHT POIDS DU VANTAIL WEIGHT OF THE VENT FLÜGELGEWICHT	MAX. 300KG
(B)	VLEUGELGEWICHT POIDS DU VANTAIL WEIGHT OF THE VENT FLÜGELGEWICHT	MIN. 300KG MAX. 400KG
	HOOGTE HAUTEUR HEIGHT HOEHE	MIN. 1895 MM



schaal - échelle
 scale - Maßstab
 1/2

D0013940

			#	
	052.5371.--		16	34.G...
	062.9396.--		2	34.G...
	068.7775.00		16	34.G...
	069.6569.04		16	34.G...
	060.8723.--		48	34.G...
	062.7894.04		4	34.G...
	052.5317.--		8	34.G...
	071.6554.XX		8	34.G...
(A)	062.7867.--		4	34.G...
(B)	062.7867.--		4	34.G...
	062.7903.--		4	34.G...
(*)	062.7902.ZC		4	34.G...
	062.7868.ZC		4	34.G...
	062.7871.--		1	34.G...
	062.7864.XX		4	34.G...
	061.7038.--		4	34.G...
(A)	062.7715.XX		2	34.G...
	050.5051.--		2	34.G...
(B)	062.7715.XX		4	34.G...
	050.5051.--		4	34.G...
	062.7717.04		2	34.G...
	062.6744.04		4	34.G...
	052.5412.--		4	34.G...
	062.8045.04		8	34.G...
	062.8011.04		2	34.G...
	062.8036.04		2	34.G...
	052.5317.--		4	34.G...
	062.8013.07		1	34.G...
	052.5317.--		4	34.G...
	052.5310.--		4xH (3/m)	34.G...
	052.5317.--		2xH (3/m)	34.G...
	052.5314.--		H (3/m)	34.G...
	062.9372.04		1	34.G...
	062.9375.04		1	34.G...
(A)	069.8722.04		32 (-250KG)	34.G...
(A)	069.8722.04		24 (+250KG)	34.G...
	069.8724.04		8	34.G...
(B)	069.8722.04		24	34.G...
	069.8724.04		16	34.G...
	062.6857.04		2	34.G...
	069.6830.04		min. 2	34.G...
	080.9104.SY		(2xB)+(8xH)	34.G...
	080.9114.SY		(2xB)+(8xH)	34.G...
	080.9381.04		(2xB)+(4xH)	34.G...
	080.9424.04		(4xB)+(7xH)	34.G...
	081.9241.07		6xH	34.G...

(*) Afhankelijk van de hoogte
Dépend de l'hauteur
Dependent of the height
Von der Höhe abhängig

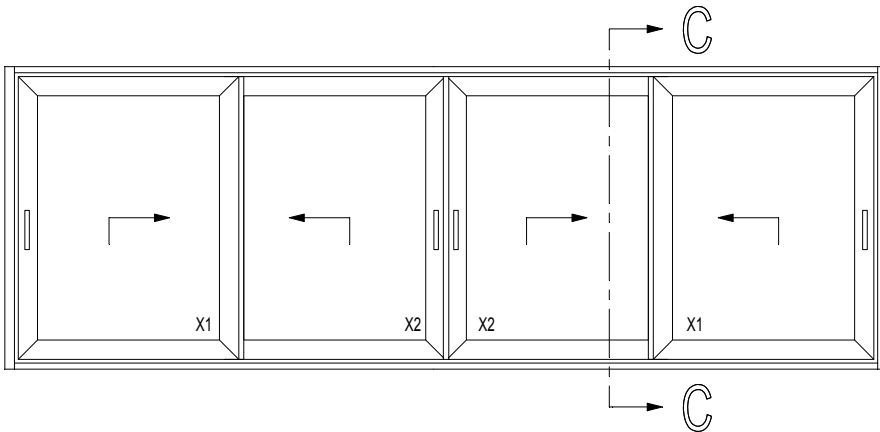

(A)	VLEUGELGEWICHT POIDS DU VANTAIL WEIGHT OF THE VENT FLÜGELGEWICHT	MAX. 300KG
(B)	VLEUGELGEWICHT POIDS DU VANTAIL WEIGHT OF THE VENT FLÜGELGEWICHT	MIN. 300KG MAX. 400KG
	HOOGTE HAUTEUR HEIGHT HOEHE	MIN. 1895 MM

			#	$\leftarrow L_m \rightarrow$	
006.1300.XX 006.1301.04			1	B-100	34.C....
011.4631.--			2	B-100	34.C....
006.1302.XX			1	B-100	34.C....
006.1303.04			1	B-100	34.C....
006.1306.XX			2	H	34.C....
006.0305.04			2	H - 150	34.C....
006.1340.XX			4	$(Bx:2)+40.5$	34.C....
			4	Bq-15.5	
			8	H-114	
006.1342.XX			4	H-114	34.C....
006.1341.04			4	H-114	34.C....
006.1343.00			2	H-171	34.C....
006.0345.XX			1	H-114	34.C....
030.3614.XX			4	$(Bx2:2)-113.5$	34.C....
			4	Bx1-169.5	
			8	H-318	
(A) 0M0.1505.XX			2	$(Bx2:2)-622.5$	34.C....
			2	Bx1-678.5	
(B) 0M0.1505.XX			8	40	34.C....
			2	$(Bx2:2)-1278.5$	
			2	Bx1-1334.5	

$bx2 = (Bx2:2)-125.5$
$hx2 = H-280$
$bx1 = Bx1-181.5$
$hx1 = H-280$

C - C

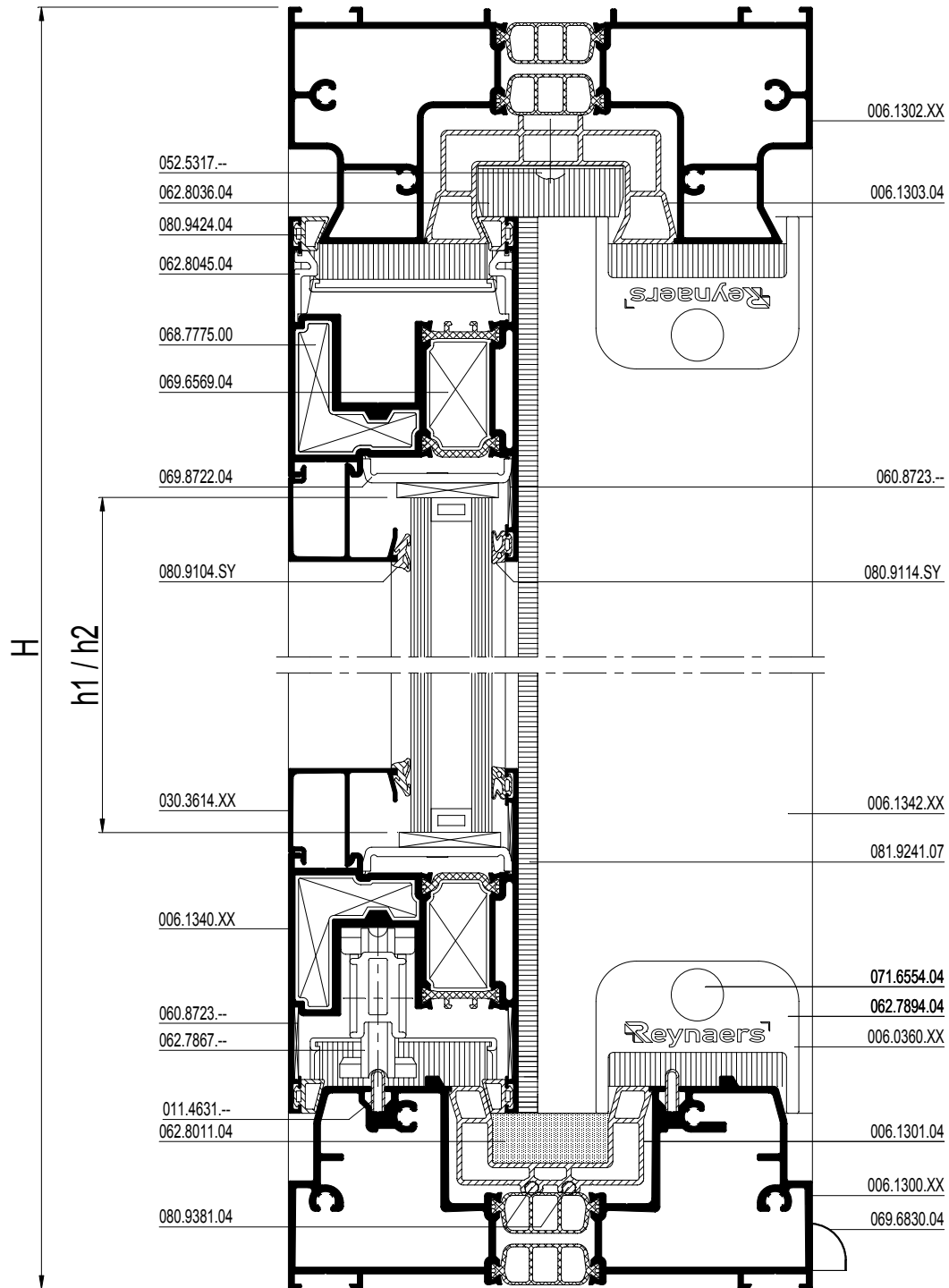

CP 155-LS

2-RAIL QXQ
 2-RAIL QXQ
 2-RAIL QXQ
 2-RAIL QXQ

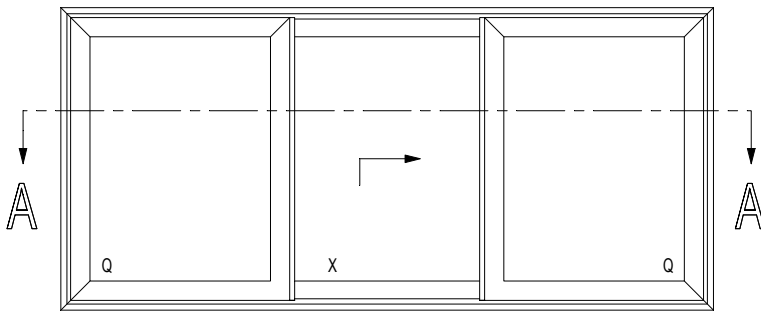

(A)	VLEUGELGEWICHT POIDS DU VANTAIL WEIGHT OF THE VENT FLÜGELGEWICHT	MAX. 300KG
-----	---	------------

(B)	VLEUGELGEWICHT POIDS DU VANTAIL WEIGHT OF THE VENT FLÜGELGEWICHT	MIN. 300KG MAX. 400KG
-----	---	--------------------------

	HOOGTE HAUTEUR HEIGHT HOEHE	MIN. 1895 MM
--	--------------------------------------	--------------

A - A

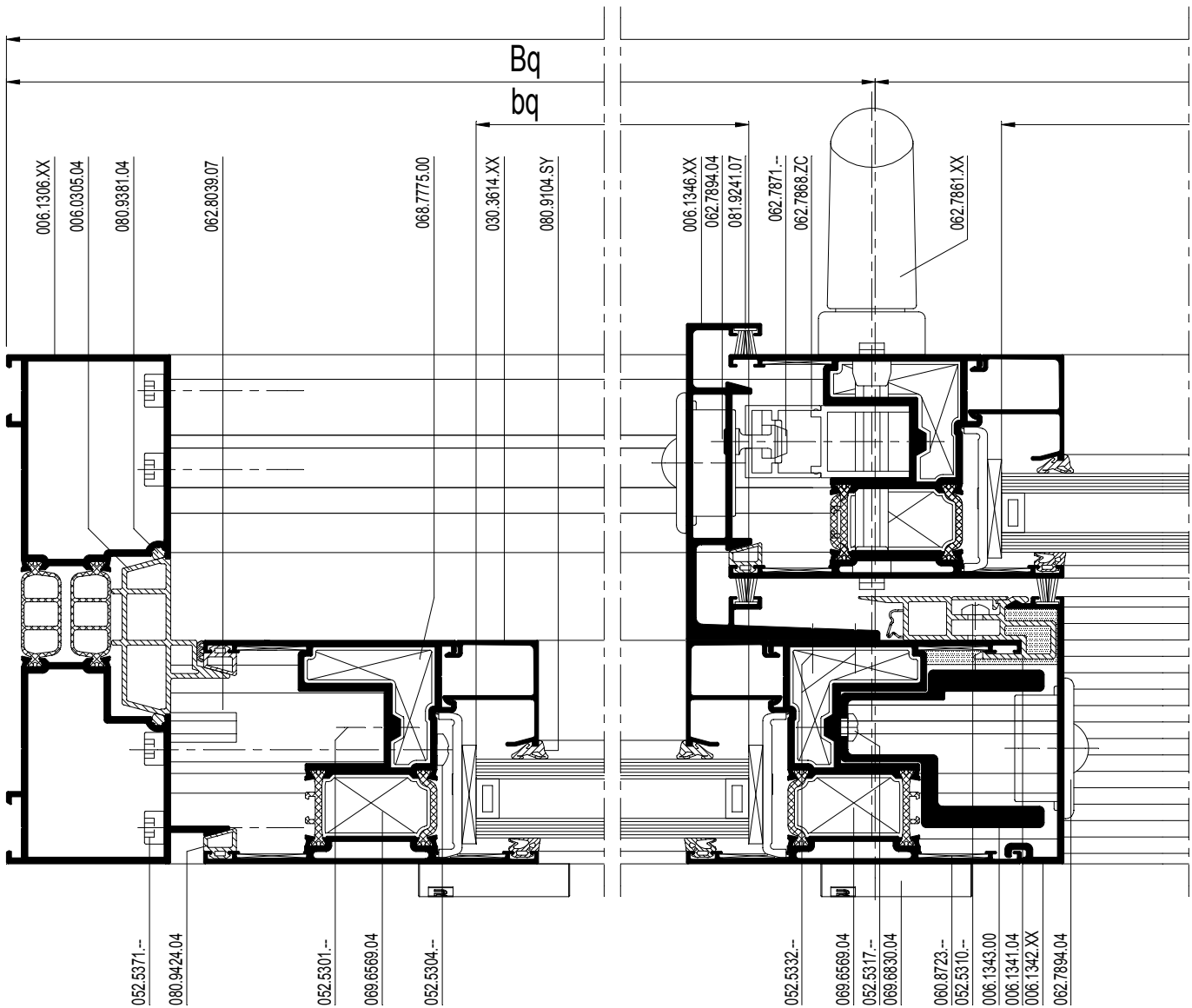

schaal - échelle
 scale - Maßstab
 1/2
 D0046860

	---	or	---	or 097.0436.00
	---	or	---	or 097.0437.00

	095.A700.00 or 095.B300.00		
	095.A730.00	095.B323.00	

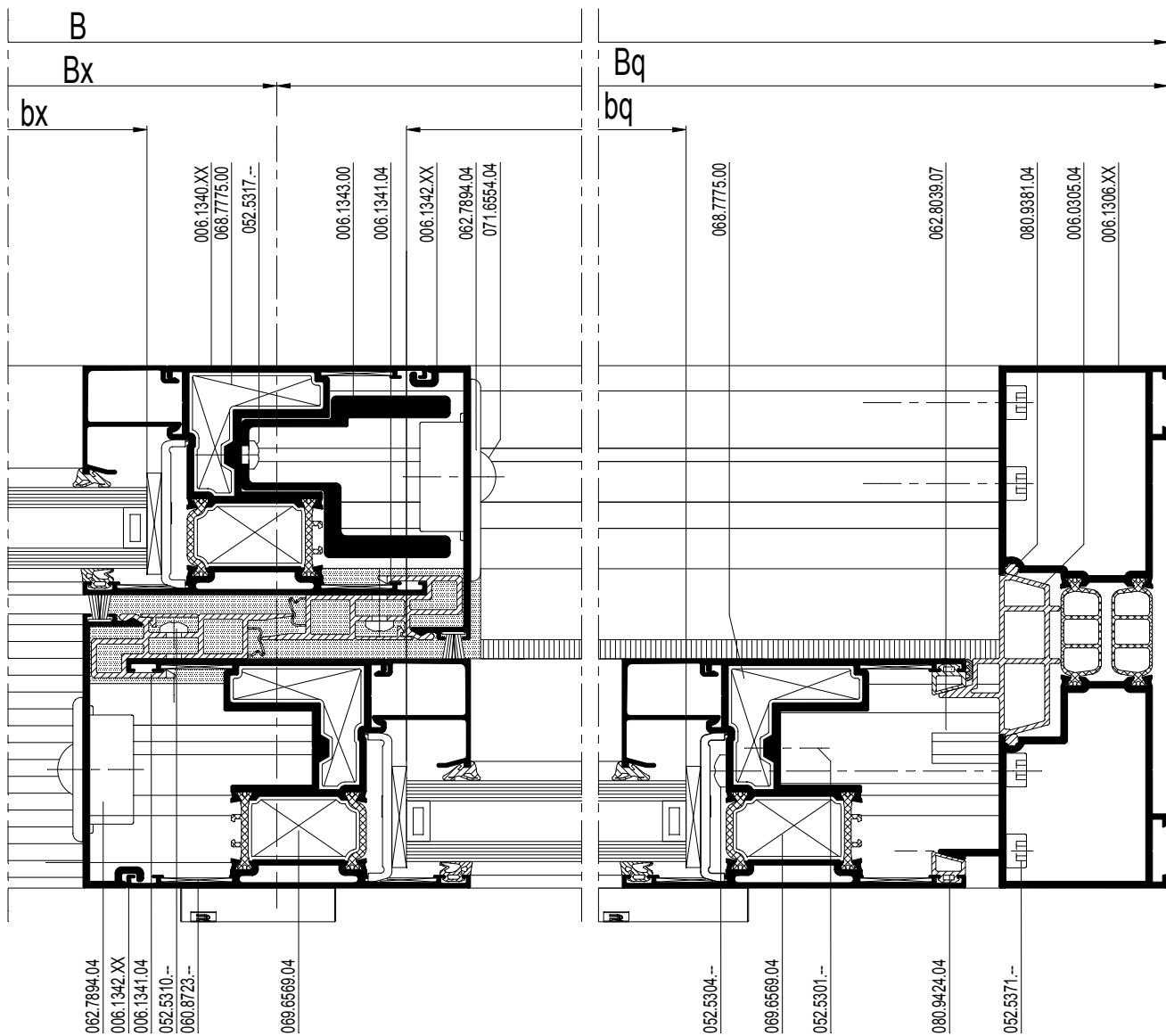

schaal - échelle
 scale - Maßstab
 1/2

D0046860

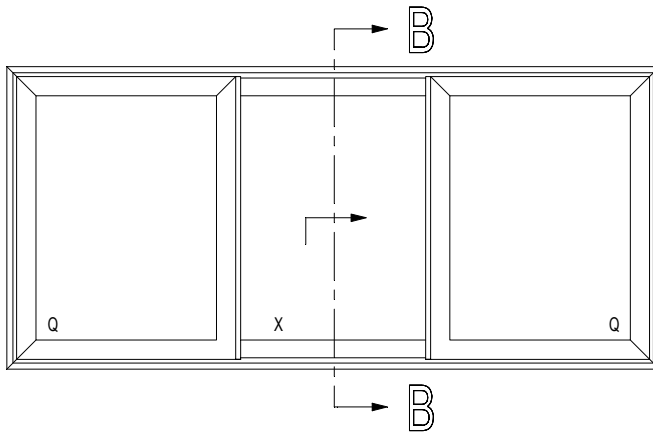

			#	$\leftarrow L_m \rightarrow$	
006.1300.XX 006.1301.04			1	B-100	34.C....
011.4631.--			1	B-100	34.C....
006.1302.XX			1	B-100	34.C....
006.1303.04			1	B-100	34.C....
006.1306.XX			2	H	34.C....
006.0305.04			2	H - 150	34.C....
006.1340.XX			2	Bx+89	34.C....
			4	Bq-15.5	
			6	H-114	
006.1342.XX			3	H-114	34.C....
006.1346.XX			1	H-114	34.C....
006.1341.04			3	H-114	34.C....
006.1343.00			2	H-171	34.C....
030.3614.XX			2	Bx-65	34.C....
			4	Bq-169.5	
			6	H-318	
006.0360.XX			1	Bx-121	34.C....
(A) 0M0.1505.XX			1	Bx-574	34.C....
(B) 0M0.1505.XX			2	40	34.C....
			1	Bx-1230	34.C....

		#	
052.5371.--		16	34.G....
062.9396.--		2	34.G....
068.7775.00		12	34.G....
069.6569.04		12	34.G....
060.8723.--		36	34.G....
062.7894.04		4	34.G....
052.5317.--		8	34.G....
071.6554.04		8	34.G....
(A) 062.7867.--		1	34.G....
(B) 062.7867.--		1	34.G....
		062.7903.--	1
(*) 062.7902.ZC <small>OF-DIJOOR-ODER</small>		1	34.G....
		062.7868.ZC	1
062.7871.--		1	34.G....
062.7861.XX		1	34.G....
(A) 062.7715.XX		1	34.G....
050.5051.--		1	34.G....
(B) 062.7715.XX		2	34.G....
		050.5051.--	2
062.8038.07		6	34.G....
052.5301.--		6	34.G....
062.8039.07		6	34.G....
052.5301.--		6	34.G....
052.5304.--		12	34.G....
062.8045.04		2	34.G....
062.8011.04		2	34.G....
062.8036.04		2	34.G....
053.5317.--		4	34.G....
052.5310.--		3xH (3/m)	34.G....
052.5317.--		2xH (3/m)	34.G....
052.5332.--		H (6/m)	34.G....
062.9372.04		1	34.G....
062.9375.04		1	34.G....
(A) 069.8722.04		24 (-250KG)	34.G....
(A) 069.8722.04		18 (+250KG)	34.G....
		069.8724.04	6
(B) 069.8722.04		18	34.G....
		069.8724.04	12
062.6857.04		2	34.G....
069.6830.04		min. 2	34.G....
080.9104.SY		(2xB)+(6xH)	34.G....
080.9114.SY		(2xB)+(6xH)	34.G....
080.9381.04		(2xB)+(4xH)	34.G....
080.9424.04		(4xB)+(5xH)	34.G....
081.9241.07		(5xH)+(Bx)	34.G....

(*) Afhankelijk van de hoogte
Dépend de l'hauteur
Dependent of the height
Von der Höhe abhängig

HOOGTE HAUTEUR HEIGHT HOEHE	MIN. 1895 MM
--------------------------------------	--------------

(A) VLEUGELGEWICHT POIDS DU VANTAIL WEIGHT OF THE VENT FLÜGELGEWICHT	MAX. 300KG
---	------------

(B) VLEUGELGEWICHT POIDS DU VANTAIL WEIGHT OF THE VENT FLÜGELGEWICHT	MIN. 300KG MAX. 400KG
---	--------------------------

bx = Bx-77
hx = H-280
bq = Bq-181.5
hq = H-280

B - B

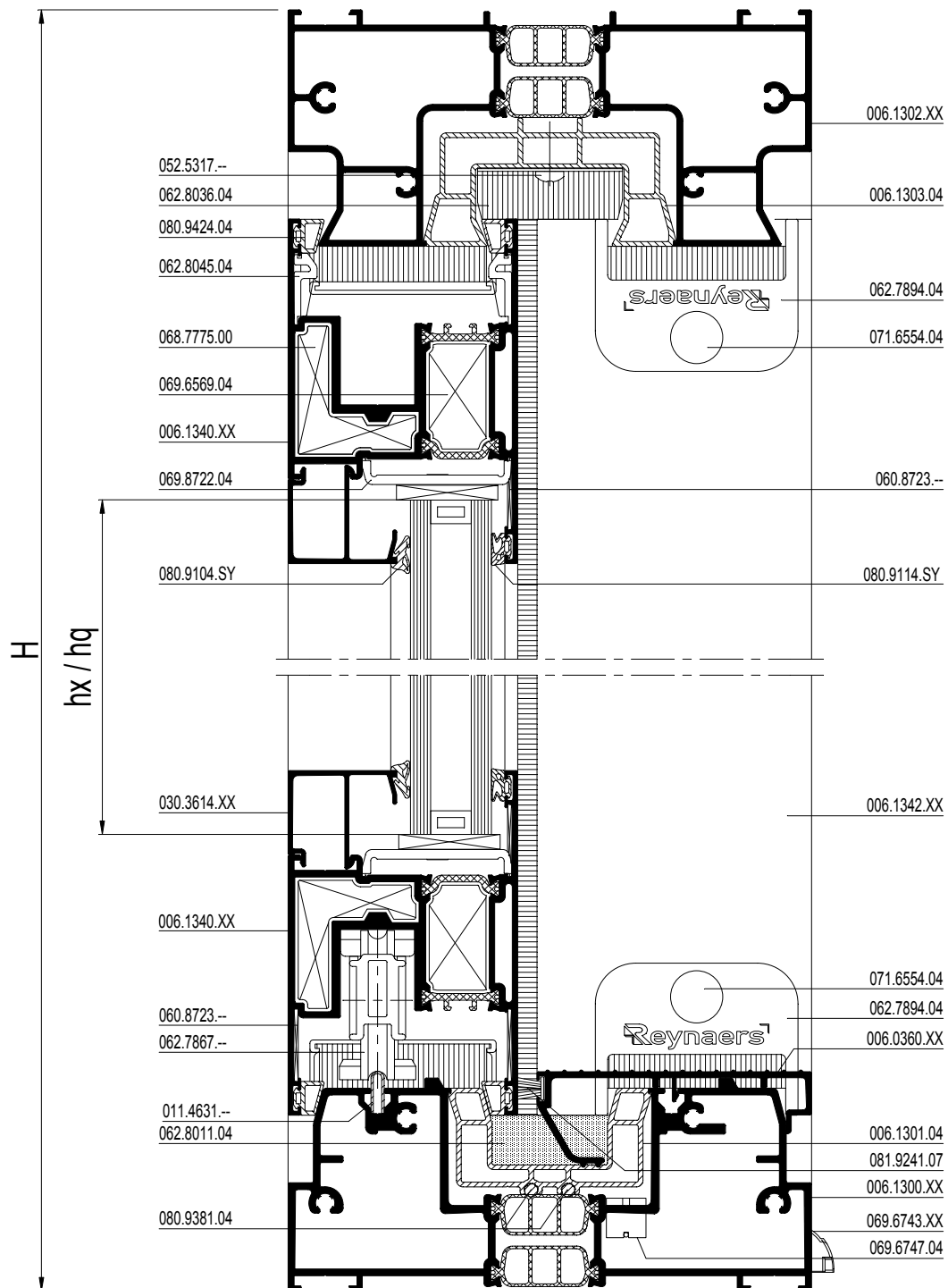

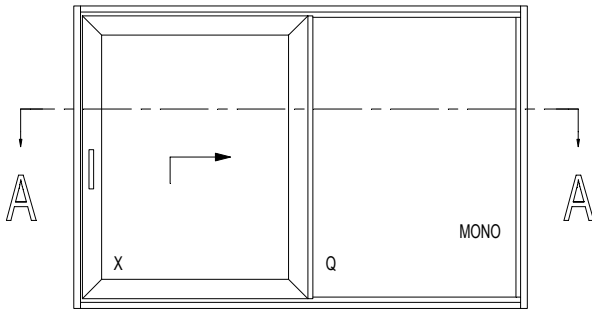

(A)	VLEUGELGEWICHT POIDS DU VANTAIL WEIGHT OF THE VENT FLÜGELGEWICHT	MAX. 300KG
-----	---	------------

(B)	VLEUGELGEWICHT POIDS DU VANTAIL WEIGHT OF THE VENT FLÜGELGEWICHT	MIN. 300KG MAX. 400KG
-----	---	--------------------------

	HOOGTE HAUTEUR HEIGHT HOEHE	MIN. 1895 MM
--	--------------------------------------	--------------

A - A

B

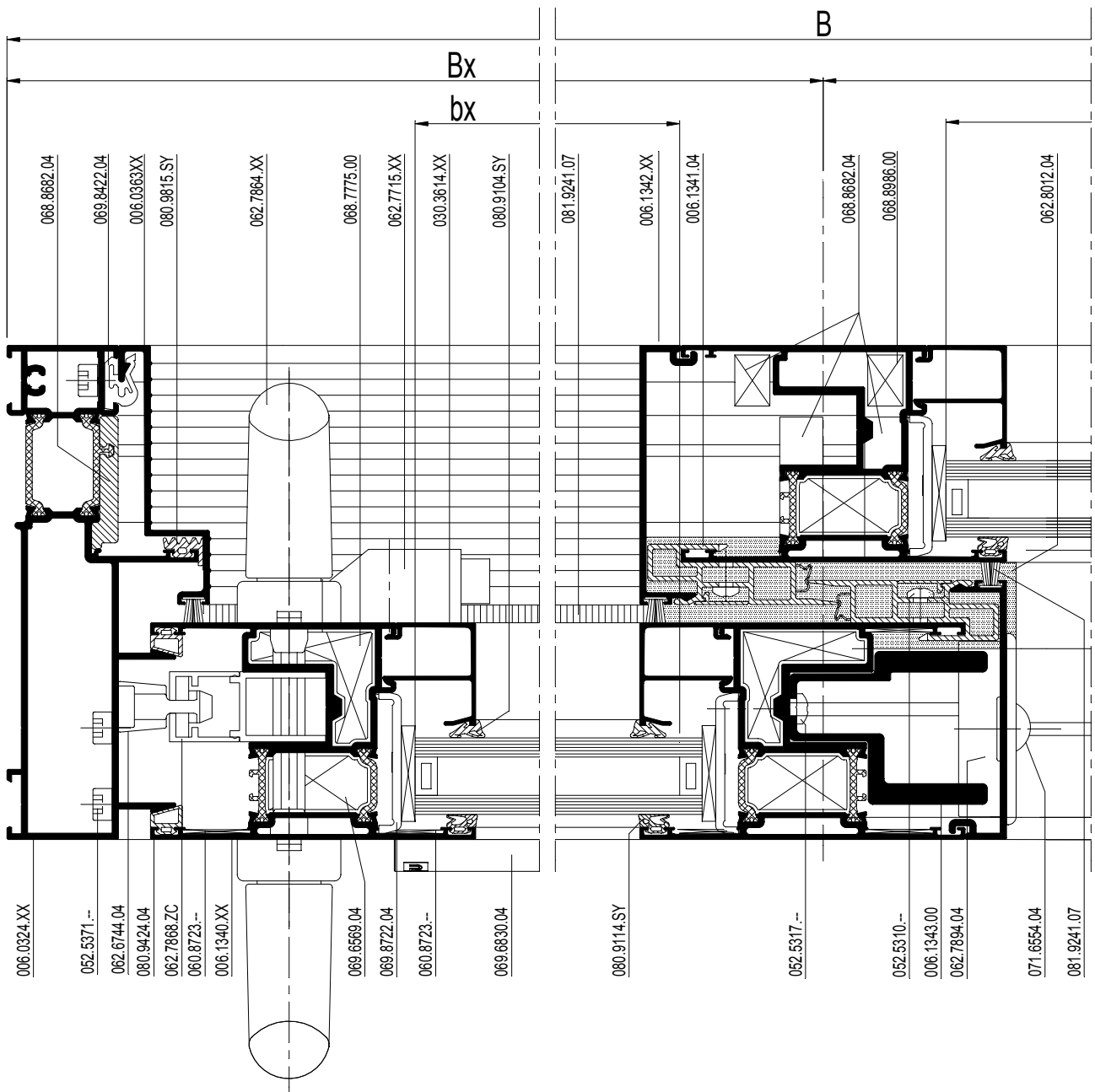

006.0324.XX

052.5371.--

062.6744.04

080.9424.04

062.7868.ZC

060.8723.--

006.1340.XX

069.6569.04

069.8722.04

060.8723.--

069.6830.04

080.9114.SY

052.5317.--

052.5310.--

006.1343.00

062.7894.04

071.6554.04

081.9241.07

068.8682.04

069.8422.04

006.0363.XX

080.9815.SY

062.7864.XX

068.7775.00

062.7715.XX

030.3614.XX

080.9104.SY

081.9241.07

006.1342.XX

006.1341.04

068.8682.04

068.8986.00

062.8012.04

		or		or	
	---	or	---	or	097.0436.00
	---	or	---	or	097.0437.00

		or	
	095.A700.00	or	095.B300.00
	095.A730.00		095.B323.00

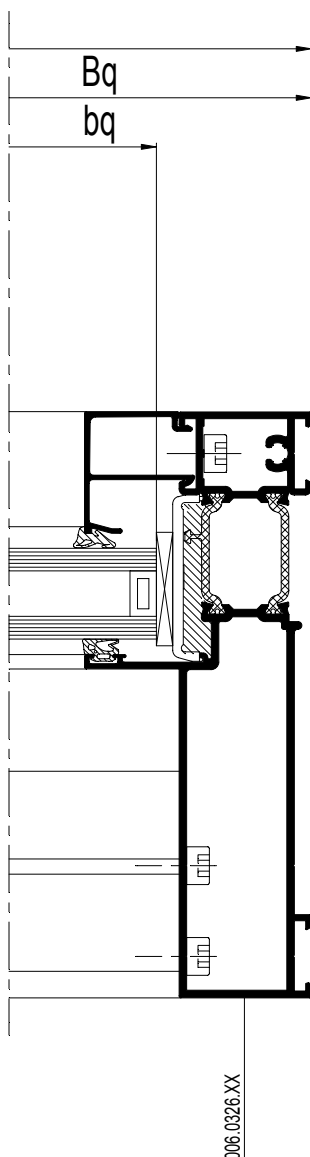

			#	
	052.5371.--		12	34.G...
	062.9397.--		2	34.G...
	068.8682.04		12	34.G...
	068.7775.00		4	34.G...
	069.6569.04		4	34.G...
	060.8723.--		12	34.G...
	068.8730.00		4	34.G...
	052.5333.--		2	34.G...
	050.5153.--		2	34.G...
	062.7894.04		1	34.G...
	052.5317.--		2	34.G...
	071.6554.XX		2	34.G...
(A)	062.7867.--		1	34.G...
(B)	062.7867.--		1	34.G...
	062.7903.--		1	34.G...
(*)	062.7902.ZC		1	34.G...
	062.7868.ZC		1	34.G...
	062.7864.XX		1	34.G...
	061.7038.--		1	34.G...
(A)	062.7715.XX		1	34.G...
	050.5051.--		1	34.G...
(B)	062.7715.XX		2	34.G...
	050.5051.--		2	34.G...
	062.6744.04		2	34.G...
	053.5412.--		2	34.G...
	062.8045.04		2	34.G...
	062.8012.04		1	34.G...
	062.8037.04		1	34.G...
	052.5317.--		2	34.G...
	052.5310.--		2xH (3/m)	34.G...
	052.5317.--		H (3/m)	34.G...
(A)	069.8722.04		16 (-250KG)	34.G...
(A)	069.8722.04		12 (+250KG)	34.G...
	069.8724.04		4	34.G...
(B)	069.8722.04		12	34.G...
	069.8724.04		8	34.G...
	069.8422.04		B (3/m)+H (3/m)	34.G...
	069.6830.04		min. 2	34.G...
	069.6747.04		2	34.G...
	080.9104.SY		(2xB)+(4xH)	34.G...
	080.9114.SY		(2xB)+(4xH)	34.G...
	080.9424.04		(2xB)+(2xH)	34.G...
	081.9241.07		(1xB)+(3xH)	34.G...
	080.9815.SY		B+H	34.G...



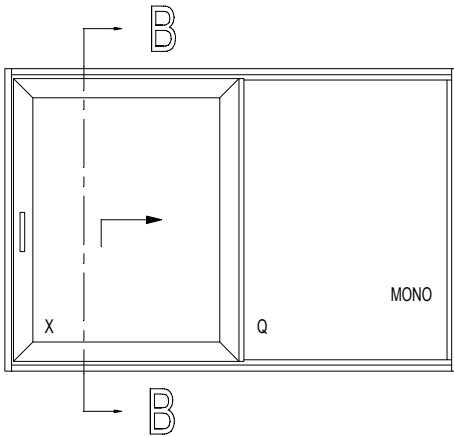



































(*) Afhankelijk van de hoogte
Dépend de l'hauteur
Dependent of the height
Von der Höhe abhängig



(A)	VLEUGELGEWICHT POIDS DU VANTAIL WEIGHT OF THE VENT FLÜGELGEWICHT	MAX. 300KG
-----	---	------------

(B)	VLEUGELGEWICHT POIDS DU VANTAIL WEIGHT OF THE VENT FLÜGELGEWICHT	MIN. 300KG MAX. 400KG
-----	---	--------------------------

	HOOGTE HAUTEUR HEIGHT HOEHE	MIN. 1895 MM
--	--------------------------------------	--------------

			#	$\leftarrow L_m \rightarrow$	
006.0320.XX			1	B-70	34.C...
006.1322.XX			1	B-70	34.C...
006.0324.XX			1	H	34.C...
006.0326.XX			1	H	34.C...
011.4631.--			1	B-70	34.C...
006.0362.XX			2	Bx-92.5	34.C...
006.0363.XX			1	H-128	34.C...
006.1340.XX			2	Bx-0.5	34.C...
			2	H-104	
			1	H-70	
006.1342.XX			1	H-104	34.C...
			1	H-70	
006.1341.04			2	H-104	34.C...
006.1343.00			1	H-161	34.C...
030.3614.XX			2	Bx-154.5	34.C...
			2	H-308	
			2	Bq-67.5	
			2	H-120	
(A) 0M0.1505.XX			2	Bx-678.5	34.C...
(B) 0M0.1505.XX			2	40	34.C...
			1	Bx-1334.5	

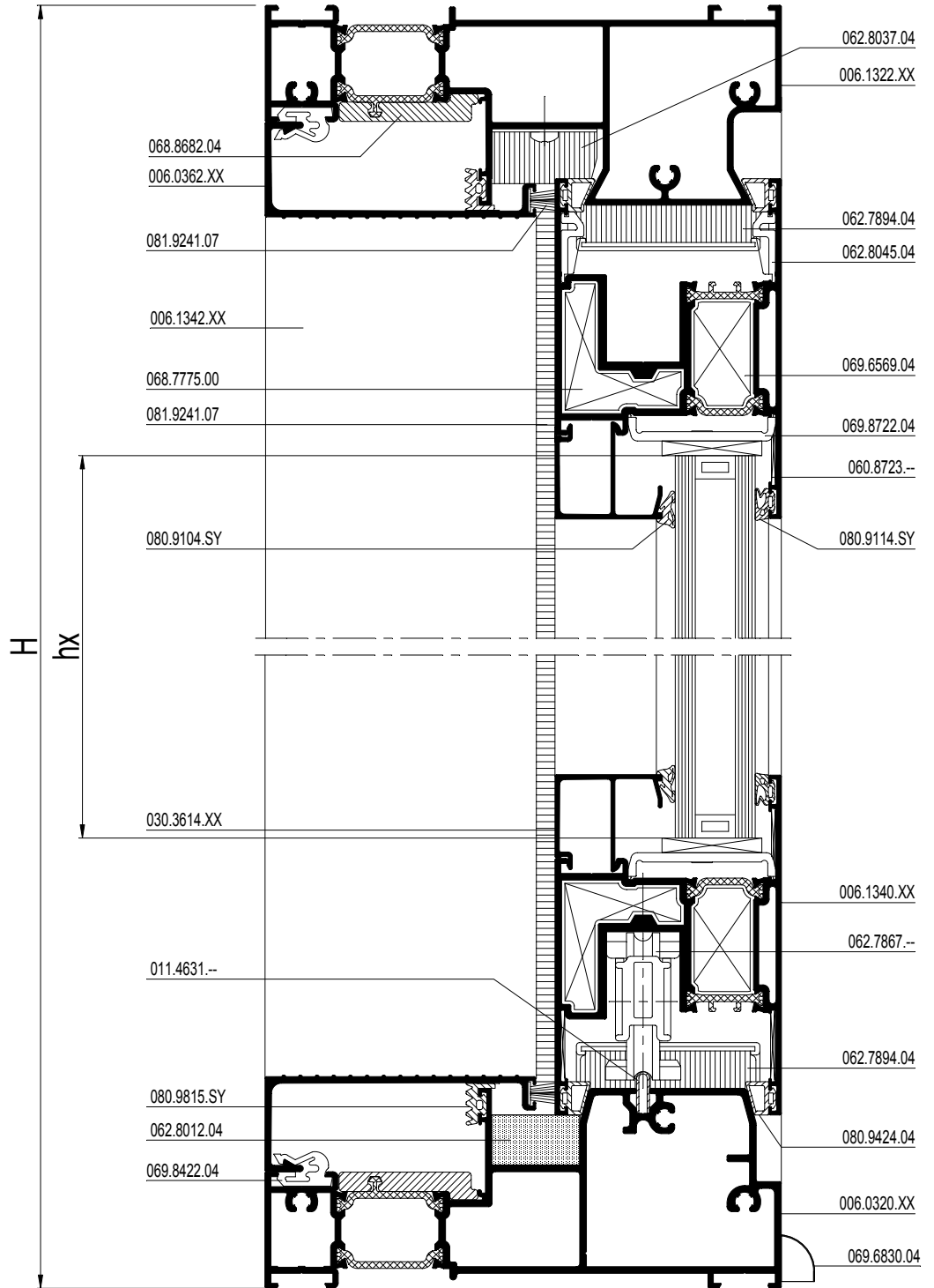

bx = Bx-167
hx = H-270
bq = Bq-80
hq = H-82

B - B

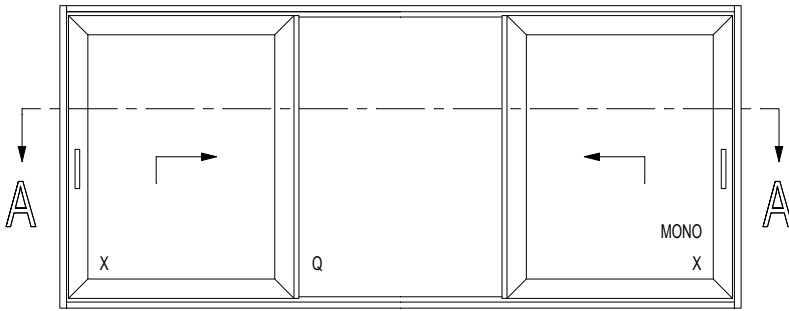

schaal - échelle
 scale - Maßstab
 1/2

D00013943



(A)	VLEUGELGEWICHT POIDS DU VANTAIL WEIGHT OF THE VENT FLÜGELGEWICHT	MAX. 300KG
-----	---	------------

(B)	VLEUGELGEWICHT POIDS DU VANTAIL WEIGHT OF THE VENT FLÜGELGEWICHT	MIN. 300KG MAX. 400KG
-----	---	--------------------------

	HOOGTE HAUTEUR HEIGHT HOEHE	MIN. 1895 MM
--	--------------------------------------	--------------

A - A

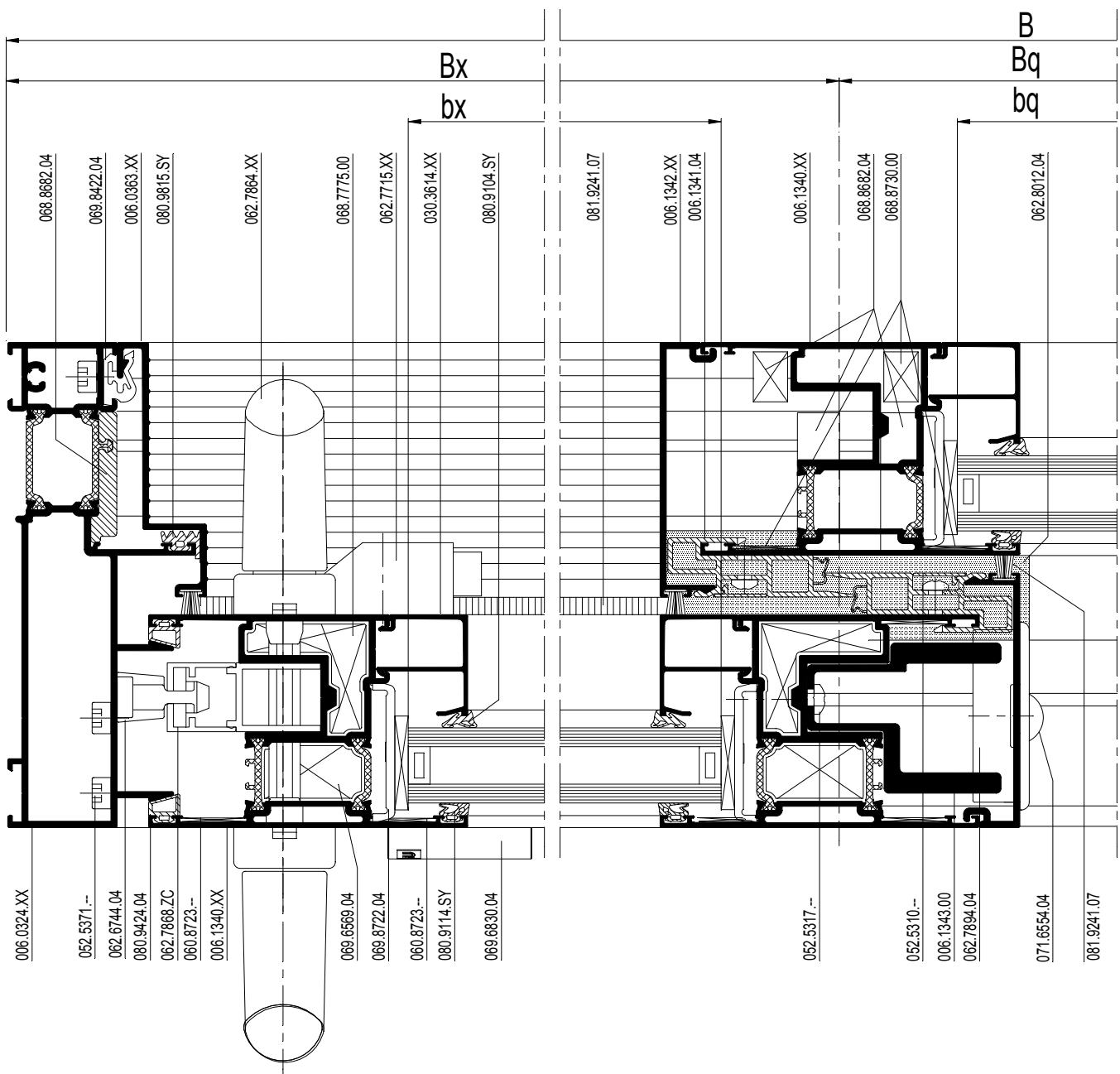

schaal - échelle
 scale - Maßstab
 1/2
 D0013944

CP 155-LS

MONORAIL XQX
 MONORAIL XQX
 MONORAIL XQX
 MONORAIL XQX



		or		or	
	---	or	---	or	097.0436.00
	---	or	---	or	097.0437.00

		or	
	095.A700.00	or	095.B300.00
	095.A730.00		095.B323.00

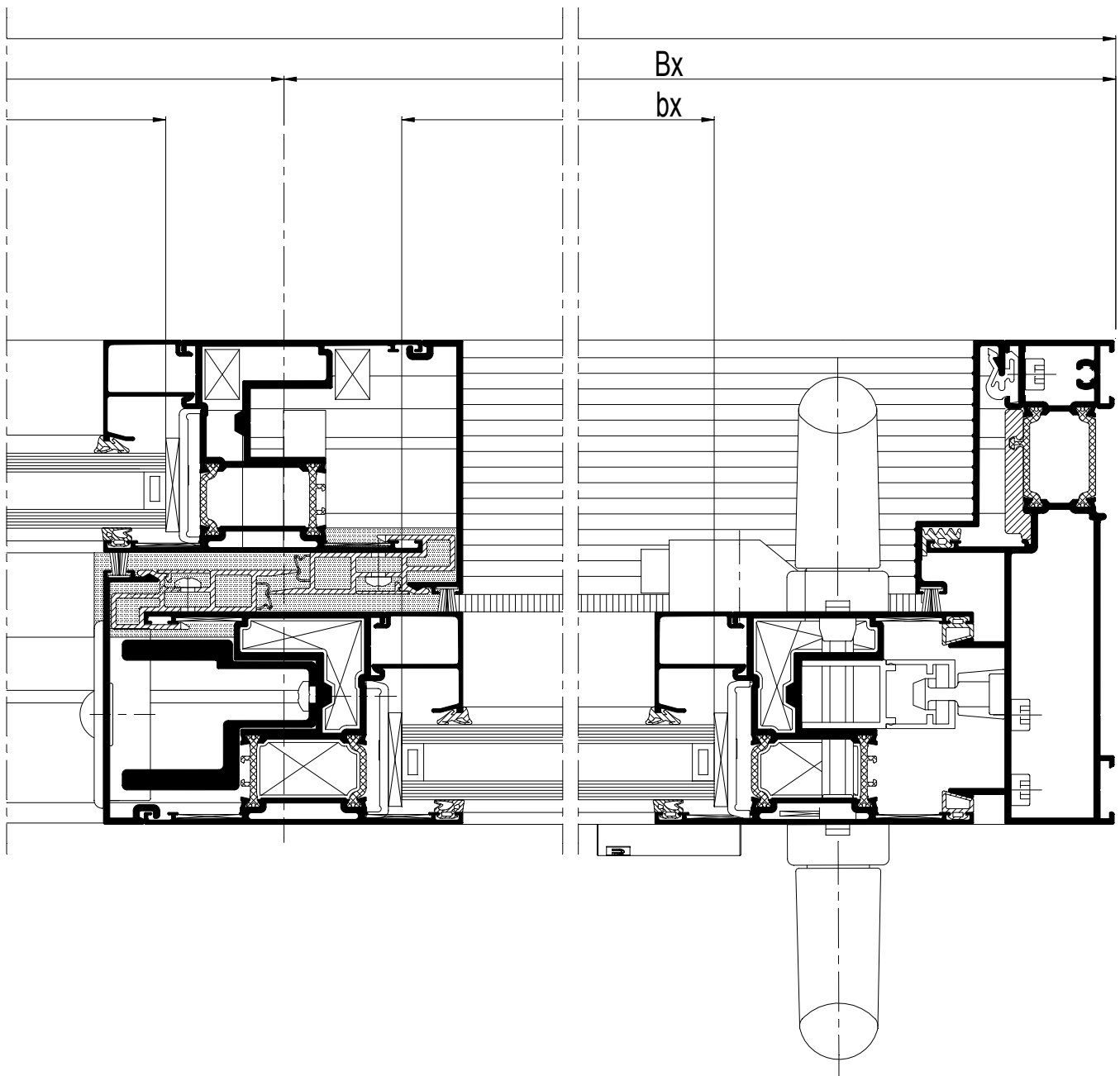

schaal - échelle
 scale - Maßstab
 1/2

D001394

CP 155-LS

MONORAIL XQX
MONORAIL XQX
MONORAIL XQX
MONORAIL XQX

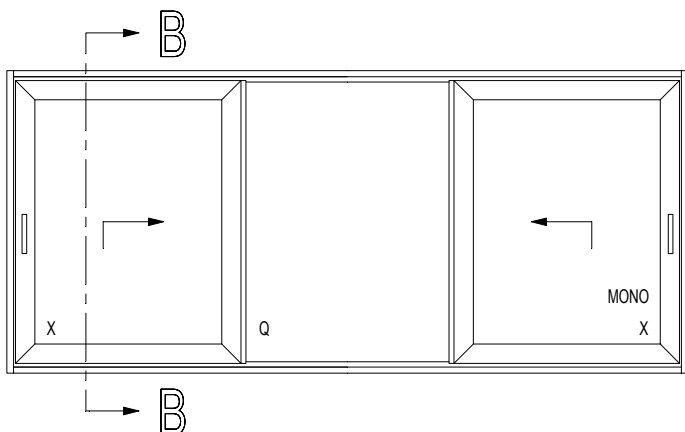

(A)	VLEUGELGEWICHT POIDS DU VANTAIL WEIGHT OF THE VENT FLÜGELGEWICHT	MAX. 300KG
-----	---	------------

(B)	VLEUGELGEWICHT POIDS DU VANTAIL WEIGHT OF THE VENT FLÜGELGEWICHT	MIN. 300KG MAX. 400KG
-----	---	--------------------------

	HOOGTE HAUTEUR HEIGHT HOEHE	MIN. 1895 MM
--	--------------------------------------	--------------

schaal - échelle
scale - Maßstab
1/2
D0013945

B - B

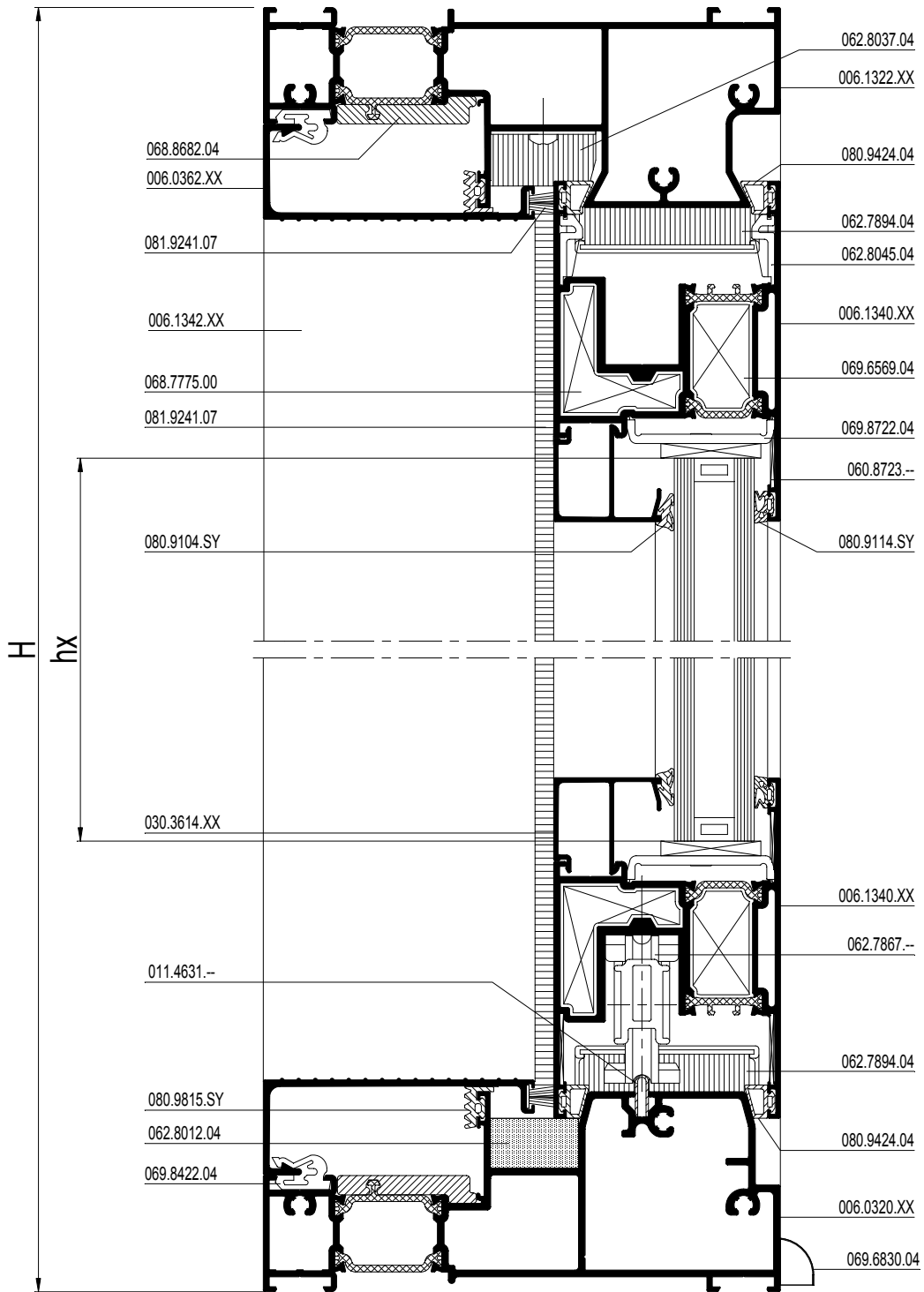

schaal - échelle
 scale - Maßstab
 1/2



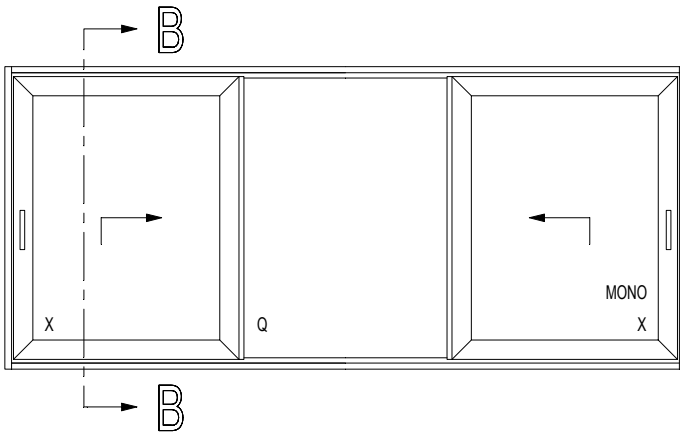











































D00013945



(A)	VLEUGELGEWICHT POIDS DU VANTAIL WEIGHT OF THE VENT FLÜGELGEWICHT	MAX. 300KG
(B)	VLEUGELGEWICHT POIDS DU VANTAIL WEIGHT OF THE VENT FLÜGELGEWICHT	MIN. 300KG MAX. 400KG
	HOOGTE HAUTEUR HEIGHT HOEHE	MIN. 1895 MM

			#	$\leftarrow L_m \rightarrow$	
006.0320.XX			1	B-70	34.C...
006.1322.XX			1	B-70	34.C...
006.0324.XX			2	H	34.C...
011.4631.--			1	B-70	34.C...
006.0362.XX			4	Bx-92.5	34.C...
006.0363.XX			2	H-128	34.C...
006.1340.XX			4	Bx+5.5	34.C...
			4	H-104	
			2	H-70	
006.1342.XX			2	H-104	34.C...
			2	H-70	
006.1341.04			4	H-104	34.C...
006.1343.00			2	H-161	34.C...
030.3614.XX			4	Bx-154.5	34.C...
			4	H-308	
			2	Bq-67.5	
			2	H-120	
(A) 0M0.1505.XX			2	Bx-678.5	34.C...
(B) 0M0.1505.XX			4	40	34.C...
			2	Bx-1334.5	

bx = Bx-167
hx = H-270
bq = Bq-77
hq = H-82

			#	
	052.5371.--		12	34.G...
	062.9397.--		2	34.G...
	068.8682.04		16	34.G...
	068.7775.00		8	34.G...
	069.6569.04		8	34.G...
	060.8723.--		24	34.G...
	068.8730.00		8	34.G...
	052.5333.--		4	34.G...
	050.5153.--		4	34.G...
	062.7894.04		2	34.G...
	052.5317.--		4	34.G...
	071.6554.XX		4	34.G...
(A)	062.7867.--		2	34.G...
(B)	062.7867.--		2	34.G...
	062.7903.--		2	34.G...
(*)	062.7902.ZC <small>OF-OU-OR-OSER</small>		2	34.G...
	062.7868.ZC		2	34.G...
	062.7864.XX		2	34.G...
	061.7038.--		2	34.G...
(A)	062.7715.XX		2	34.G...
	050.5051.--		2	34.G...
(B)	062.7715.XX		4	34.G...
	050.5051.--		4	34.G...
	062.6744.04		4	34.G...
	052.5412.--		4	34.G...
	062.8045.04		4	34.G...
	062.8012.04		2	34.G...
	062.8037.04		2	34.G...
	052.5317.--		4	34.G...
	052.5310.--		4xH (3/m)	34.G...
	052.5317.--		2xH (3/m)	34.G...
(A)	069.8722.04		24 (-250KG)	34.G...
(A)	069.8722.04		20 (+250KG)	34.G...
	069.8724.04		4	34.G...
(B)	069.8722.04		18	34.G...
	069.8724.04		8	34.G...
	069.8422.04		4xBx (3/m)	34.G...
	069.8422.04		2xH (3/m)	34.G...
	069.6830.04		min. 2	34.G...
	069.6747.04		4	34.G...
	080.9104.SY		(2xB)+(6xH)	34.G...
	080.9114.SY		(2xB)+(4xH)	34.G...
	080.9424.04		(8xB)+(4xH)	34.G...
	081.9241.07		(4xBx)+(6xH)	34.G...
	080.9815.SY		(4xBx)+(2xH)	34.G...

(*) Afhankelijk van de hoogte
Dépend de l'hauteur
Dependent of the height
Von der Höhe abhängig

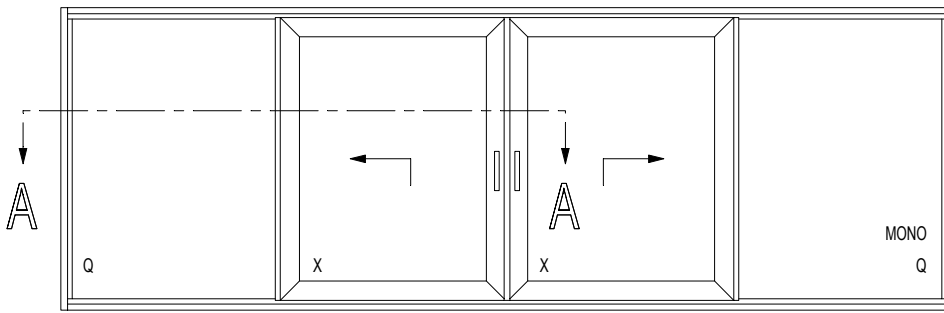

(A)	VLEUGELGEWICHT POIDS DU VANTAIL WEIGHT OF THE VENT FLÜGELGEWICHT	MAX. 300KG
-----	---	------------

(B)	VLEUGELGEWICHT POIDS DU VANTAIL WEIGHT OF THE VENT FLÜGELGEWICHT	MIN. 300KG MAX. 400KG
-----	---	--------------------------

	HOOGTE HAUTEUR HEIGHT HOEHE	MIN. 1895 MM
--	--------------------------------------	--------------

A - A

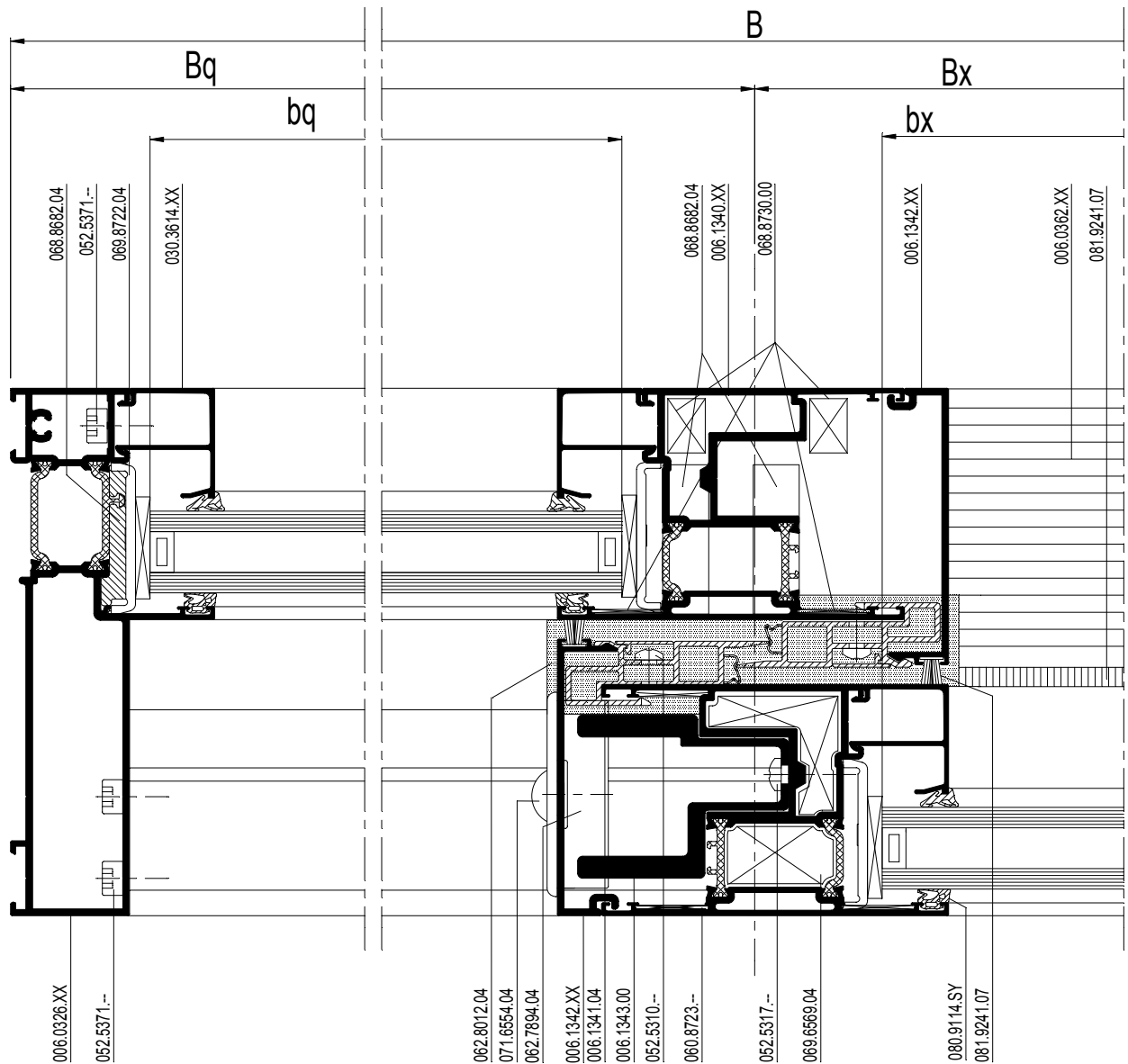

schaal - échelle
 scale - Maßstab
 1/2

D0013946

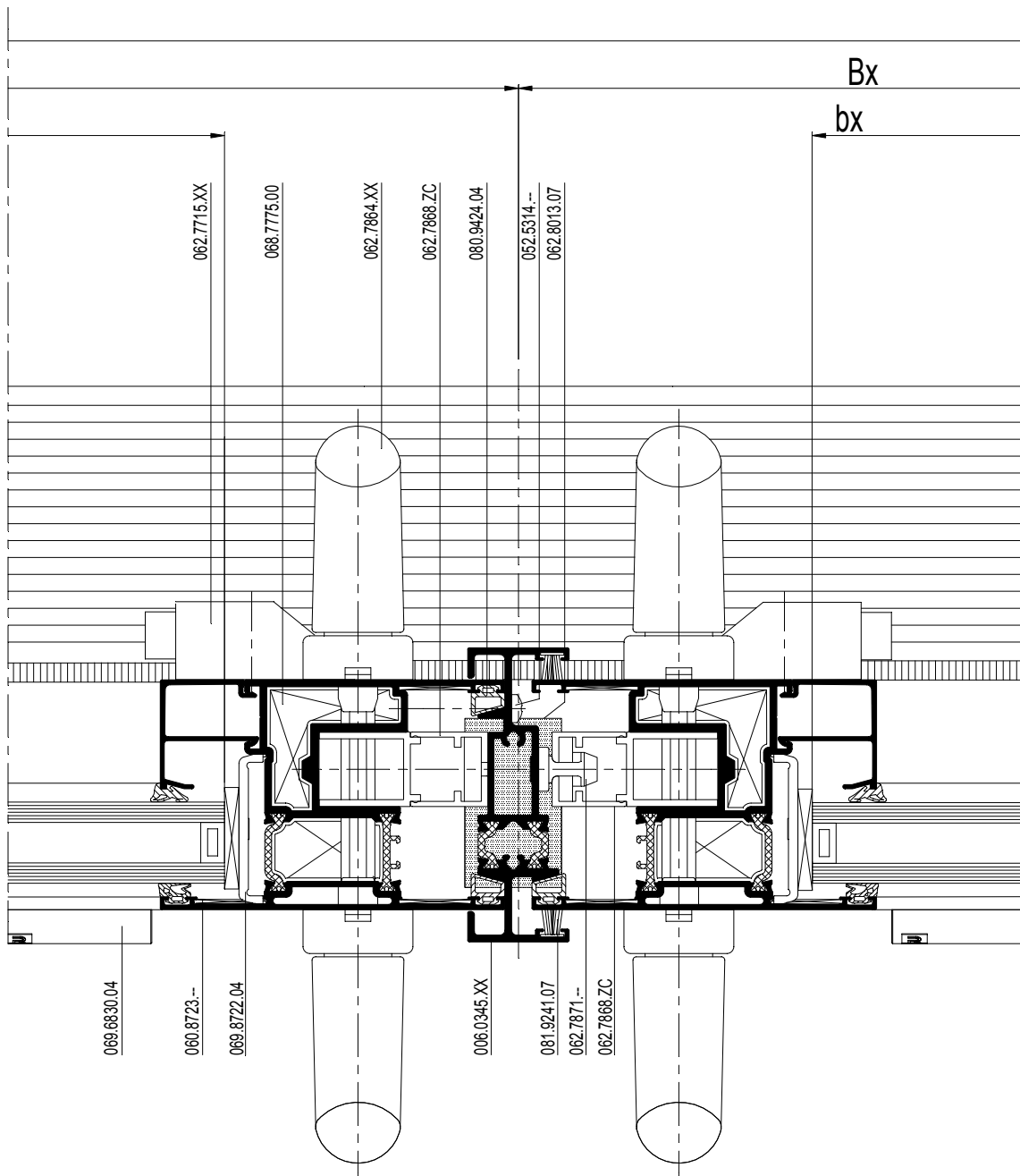

schaal - échelle
scale - Maßstab
1/2

D0013946

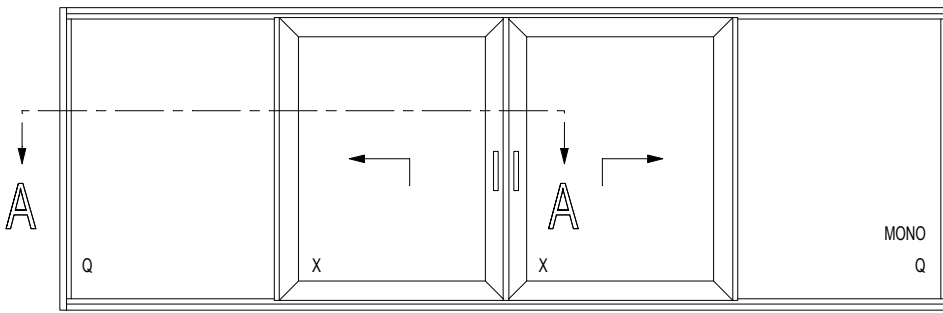





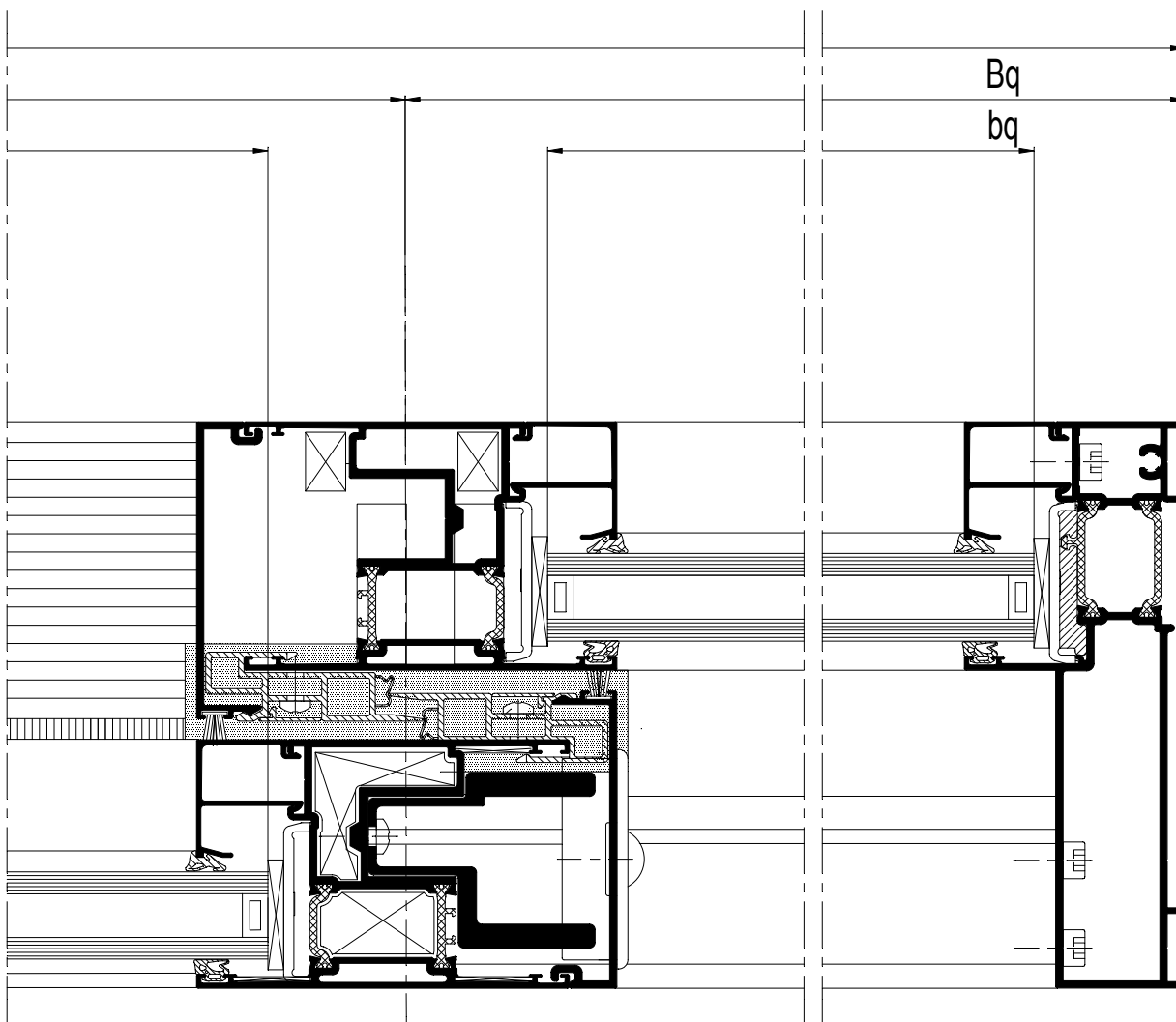









































(A)	VLEUGELGEWICHT POIDS DU VANTAIL WEIGHT OF THE VENT FLÜGELGEWICHT	MAX. 300KG
(B)	VLEUGELGEWICHT POIDS DU VANTAIL WEIGHT OF THE VENT FLÜGELGEWICHT	MIN. 300KG MAX. 400KG
	HOOGTE HAUTEUR HEIGHT HOEHE	MIN. 1895 MM

B - B



schaal - échelle
 scale - Maßstab
 1/2
 D0013947

			#	
			12	34.G...
			2	34.G...
			16	34.G...
			8	34.G...
			8	34.G...
			24	34.G...
			8	34.G...
			4	34.G...
			4	34.G...
			2	34.G...
			4	34.G...
			4	34.G...
(A)			2	34.G...
(B)			2	34.G...
			2	34.G...
(*)			2	34.G...
			2	34.G...
			1	34.G...
			2	34.G...
(A)			2	34.G...
			2	34.G...
(B)			4	34.G...
			4	34.G...
			2	34.G...
			4	34.G...
			2	34.G...
			2	34.G...
			2	34.G...
			2	34.G...
			4	34.G...
			1	34.G...
			4	34.G...
			4xH (3/m)	34.G...
			2xH (3/m)	34.G...
			H (3/m)	34.G...
(A)			32 (-250KG)	34.G...
			28 (+250KG)	34.G...
(A)			4	34.G...
(B)			28	34.G...
			8	34.G...
			2xBx (3/m)	34.G...
			min. 2	34.G...
			4	34.G...
			(2xB)+(8xH)	34.G...
			(2xB)+(8xH)	34.G...
			(8xBx)+(3xH)	34.G...
			(6xH)+(2xBx)	34.G...
			2xBx	34.G...

(*) Afhankelijk van de hoogte
Dépend de l'hauteur
Dependent of the height
Von der Höhe abhängig

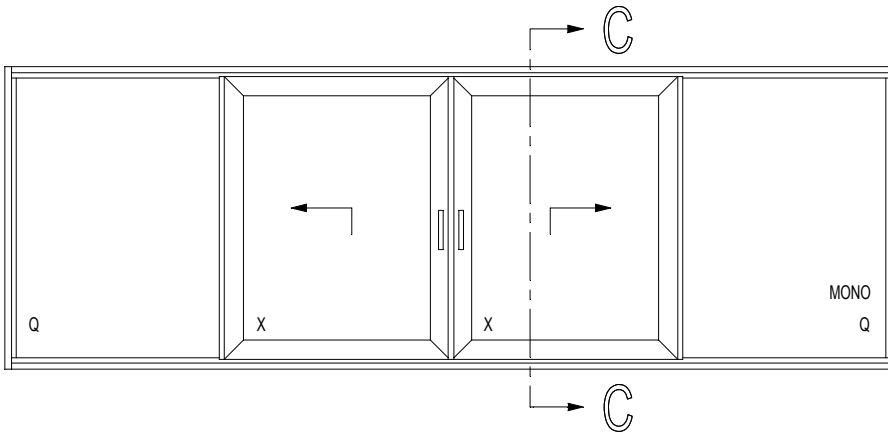

(A)	VLEUGELGEWICHT POIDS DU VANTAIL WEIGHT OF THE VENT FLÜGELGEWICHT	MAX. 300KG
(B)	VLEUGELGEWICHT POIDS DU VANTAIL WEIGHT OF THE VENT FLÜGELGEWICHT	MIN. 300KG MAX. 400KG
	HOOGTE HAUTEUR HEIGHT HOEHE	MIN. 1895 MM

			#	$\leftarrow L_m \rightarrow$	
006.0320.XX			1	B-70	34.C...
006.1322.XX			1	B-70	34.C...
006.0326.XX			2	H	34.C...
011.4631.--			1	B-70	34.C...
006.0362.XX			2	Bx-128	34.C...
006.1340.XX			4	(Bx:2)+40.5	34.C...
			4	H-104	
			2	H-70	
006.1342.XX			2	H-104	34.C...
			2	H-70	
006.1341.04			4	H-104	34.C...
006.1343.00			2	H-161	34.C...
006.0345.XX			1	H-104	34.C...
030.3614.XX			4	(Bx:2)-113.5	34.C...
			4	H-308	
			2	Bq-67.5	
			2	H-120	
(A) 0M0.1505.XX			2	(Bx:2)-623.5	34.C...
(B) 0M0.1505.XX			4	40	34.C...
			2	(Bx:2)-1278.5	

bx = (Bx:2)-126
hx = H-270
bq = Bq-80
hq = H-82

C-C

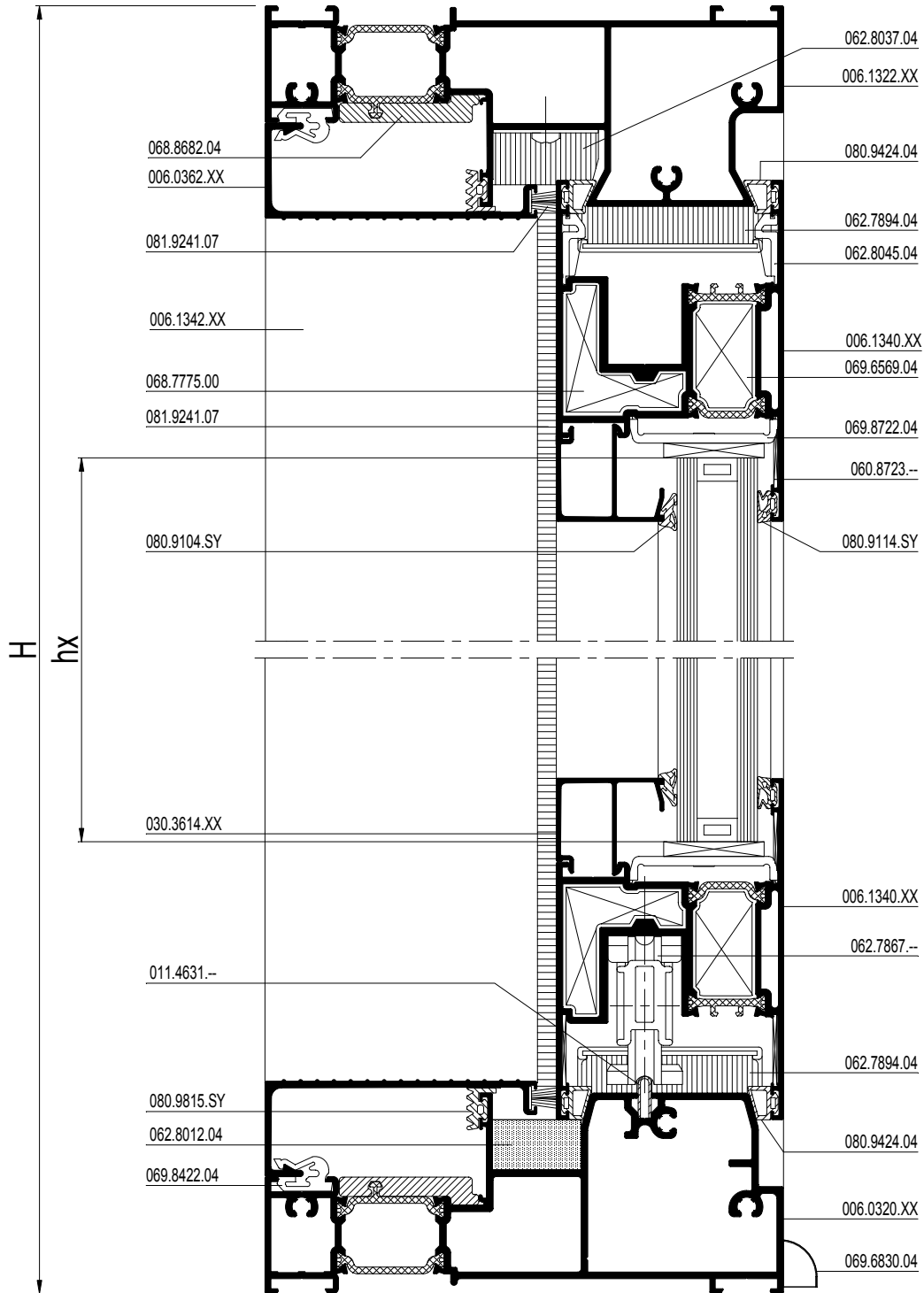

schaal - échelle
 scale - Maßstab
 1/2

D0013948

(A)	VLEUGELGEWICHT POIDS DU VANTAIL WEIGHT OF THE VENT FLÜGELGEWICHT	MAX. 300KG
-----	---	------------

(B)	VLEUGELGEWICHT POIDS DU VANTAIL WEIGHT OF THE VENT FLÜGELGEWICHT	MIN. 300KG MAX. 400KG
-----	---	--------------------------

A - A



schaal - échelle
 scale - Maßstab
 1/2
 D0044654

HOOGTE HAUTEUR HEIGHT HOEHE	MIN. 1895 MM
--------------------------------------	--------------

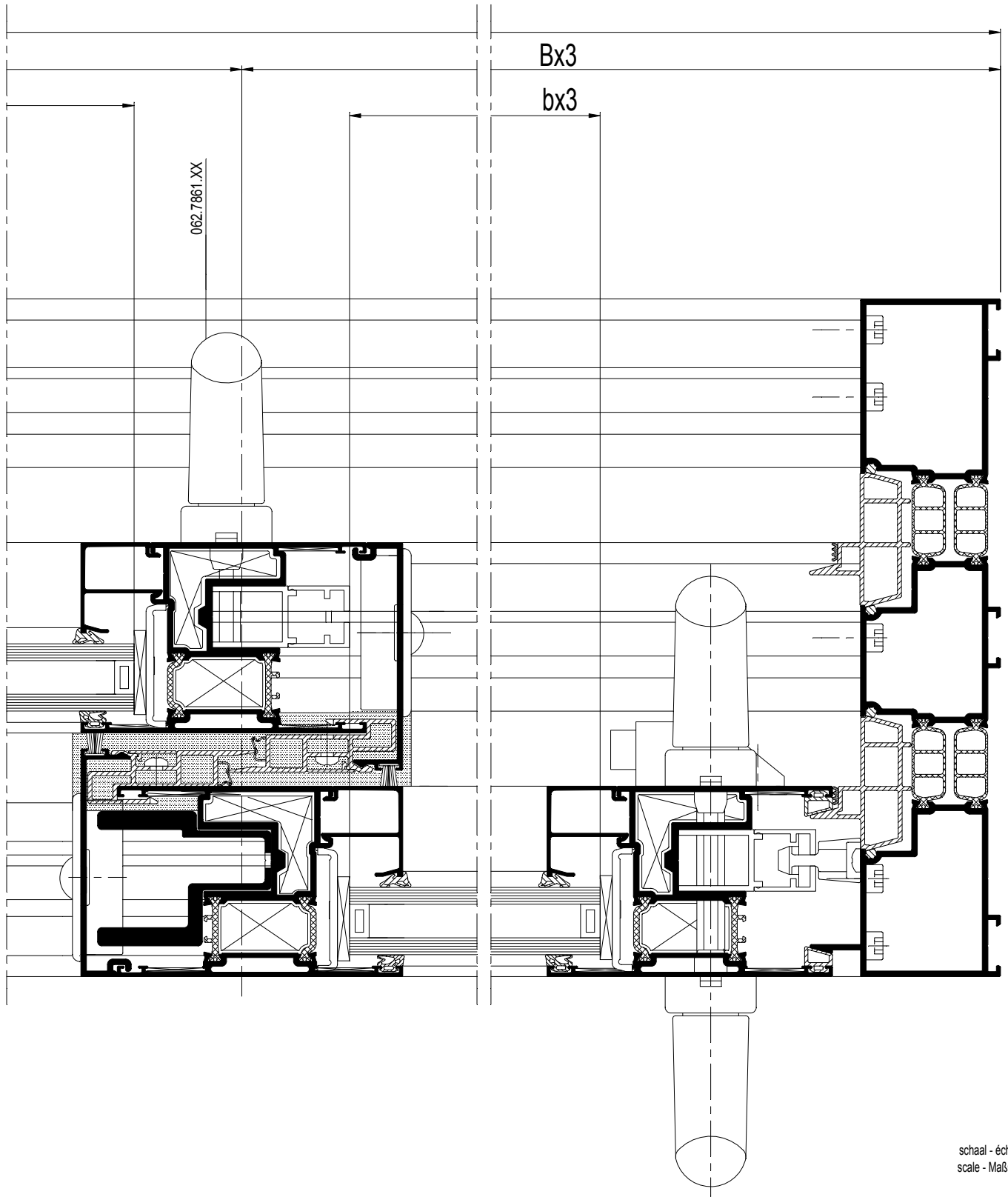

schaal - échelle
 scale - Maßstab
 1/2

D0044654

CP 155-LS

3-RAIL XXX
3-RAIL XXX
3-RAIL XXX
3-RAIL XXX

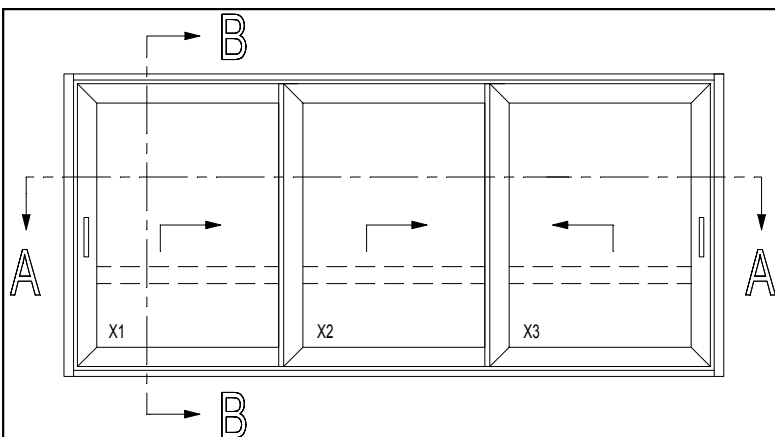

(A)	VLEUGELGEWICHT POIDS DU VANTAIL WEIGHT OF THE VENT FLÜGELGEWICHT	MAX. 300KG
-----	---	------------

(B)	VLEUGELGEWICHT POIDS DU VANTAIL WEIGHT OF THE VENT FLÜGELGEWICHT	MIN. 300KG MAX. 400KG
-----	---	--------------------------

	HOOGTE HAUTEUR HEIGHT HOEHE	MIN. 1895 MM
--	--------------------------------------	--------------

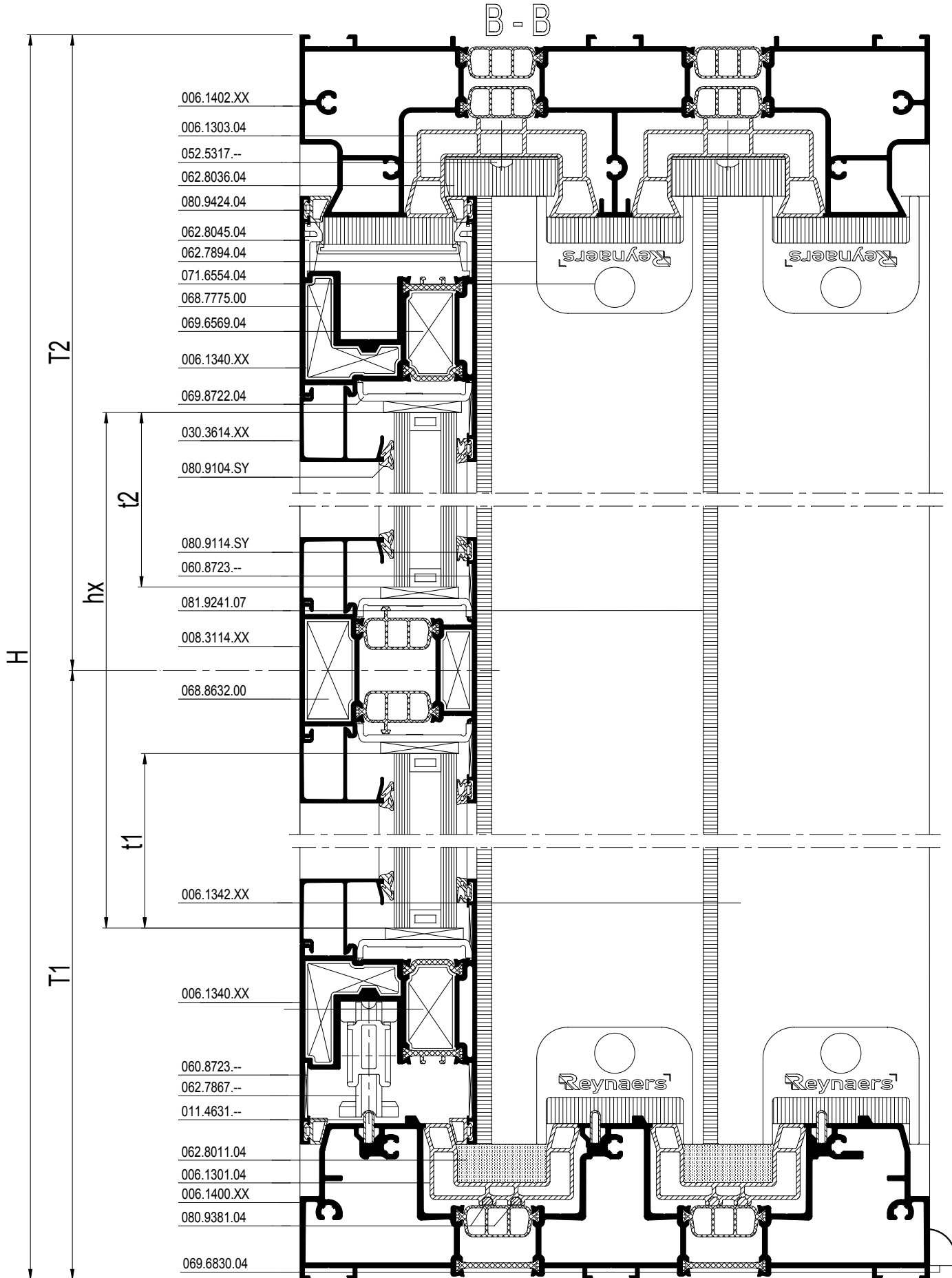

D0044639

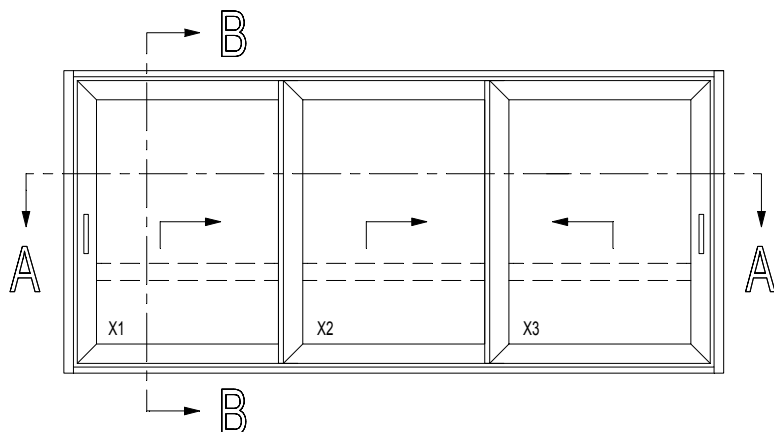

(A)	VLEUGELGEWICHT POIDS DU VANTAIL WEIGHT OF THE VENT FLÜGELGEWICHT	MAX. 300KG
-----	---	------------

(B)	VLEUGELGEWICHT POIDS DU VANTAIL WEIGHT OF THE VENT FLÜGELGEWICHT	MIN. 300KG MAX. 400KG
-----	---	--------------------------

	HOOGTE HAUTEUR HEIGHT HOEHE	MIN. 1895 MM
--	--------------------------------------	--------------

			#	← Lm →	
006.1400.XX			1	B-100	34.C...
006.1301.04			2	B-100	34.C...
011.4631.-			3	B-100	34.C...
006.1402.XX			1	B-100	34.C...
006.1303.04			2	B-100	34.C...
006.1406.XX			2	H	34.C...
006.0305.XX			4	H - 150	34.C...
006.1340.XX			2	Bx1-15.5	34.C...
			2	Bx2+89	
			2	Bx3-15.5	
			6	H-114	
006.1342.XX			4	H-114	34.C...
006.1341.04			4	H-114	34.C...
006.1343.00			2	H-171	34.C...
030.3614.XX			2	Bx1-169.5	34.C...
			2	Bx2-65	
			2	Bx3-169.5	
			6	H-318	



bx1 = Bx1-181.5
hx1= H-280
bx2 = Bx2-77
hx2 = H-280
bx3 = Bx3-181.5
hx3 = H-280

met dwarsstijl
avec traverse
with transom
mit Sprossenprofil

t1= T1-167
t2 = T2-177

				#	$\leftarrow L_m$	
(A)	OM0.1505.XX			1	Bx1-678.5	34.c.043
				1	Bx2-574	
				1	Bx3-678.5	
(B)	OM0.1505.XX			6	40	34.C.021
				1	Bx1-1334.5	
				1	Bx2-1230	
				1	Bx3-1334.5	

met dwarsstijl
avec traverse
with transom
mit Sprossenprofil
+

008.3114.XX			1	Bx1-176	34.c.043
			1	Bx2-78	
			1	Bx3-176	

			#	
052.5371.--			20	34.G...
062.9399.--			2	34.G...
068.7775.00			12	34.G...
069.6569.04			12	34.G...
060.8723.--			36	34.G...
062.7894.04			4	34.G...
052.5317.--			8	34.G...
071.6554.04			8	34.G...
(A) 062.7867.--			3	34.G...
(B) 062.7867.--			3	34.G...
(B) 062.7903.--			3	34.G...
(*) 062.7902.ZC			3	34.G...
(*) 062.7868.ZC			3	34.G...
062.7864.XX			2	34.G...
062.7861.XX			1	34.G...
061.7038.--			2	34.G...
(A) 062.7715.XX			2	34.G...
(B) 050.5051.--			2	34.G...
(B) 062.7715.XX			4	34.G...
(B) 050.5051.--			4	34.G...
062.6744.04			4	34.G...
053.5412.--			4	34.G...
062.8045.04			6	34.G...
062.8011.04			2	34.G...
062.8036.04			2	34.G...
052.5317.--			4	34.G...
052.5310.--			4xH (3/m)	34.G...
052.5317.--			2xH (3/m)	34.G...
062.9375.04			4	34.G...
(A) 069.8722.04			24	34.G...
(B) 069.8722.04			18	34.G...
(B) 069.8724.04			12	34.G...
062.6857.04			2	34.G...
069.6830.04			min. 2	34.G...
080.9104.SY			(2xB)+(6xH)	34.G...
080.9114.SY			(2xB)+(6xH)	34.G...
080.9381.04			(4xB)+(8xH)	34.G...
080.9424.04			4xH	34.G...
081.9241.07			(4xB)+(4xH)	34.G...

met dwarsstijl
avec traverse
with transom
mit Sprossenprofil
+

068.8732.00			6	34.G...
069.8722.04			24	34.G...
080.9104.SY			2xB	34.G...
080.9114.SY			2xB	34.G...

(*) Afhankelijk van de hoogte
Dépend de l'hauteur
Dependent of the height
Von der Höhe abhängig

HOOGTE HAUTEUR HEIGHT HOEHE	MIN. 1895 MM
--------------------------------------	--------------

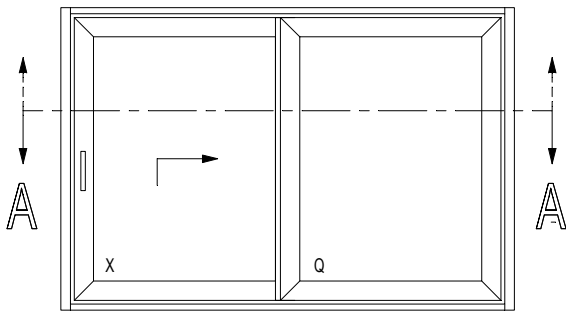

A - A

B

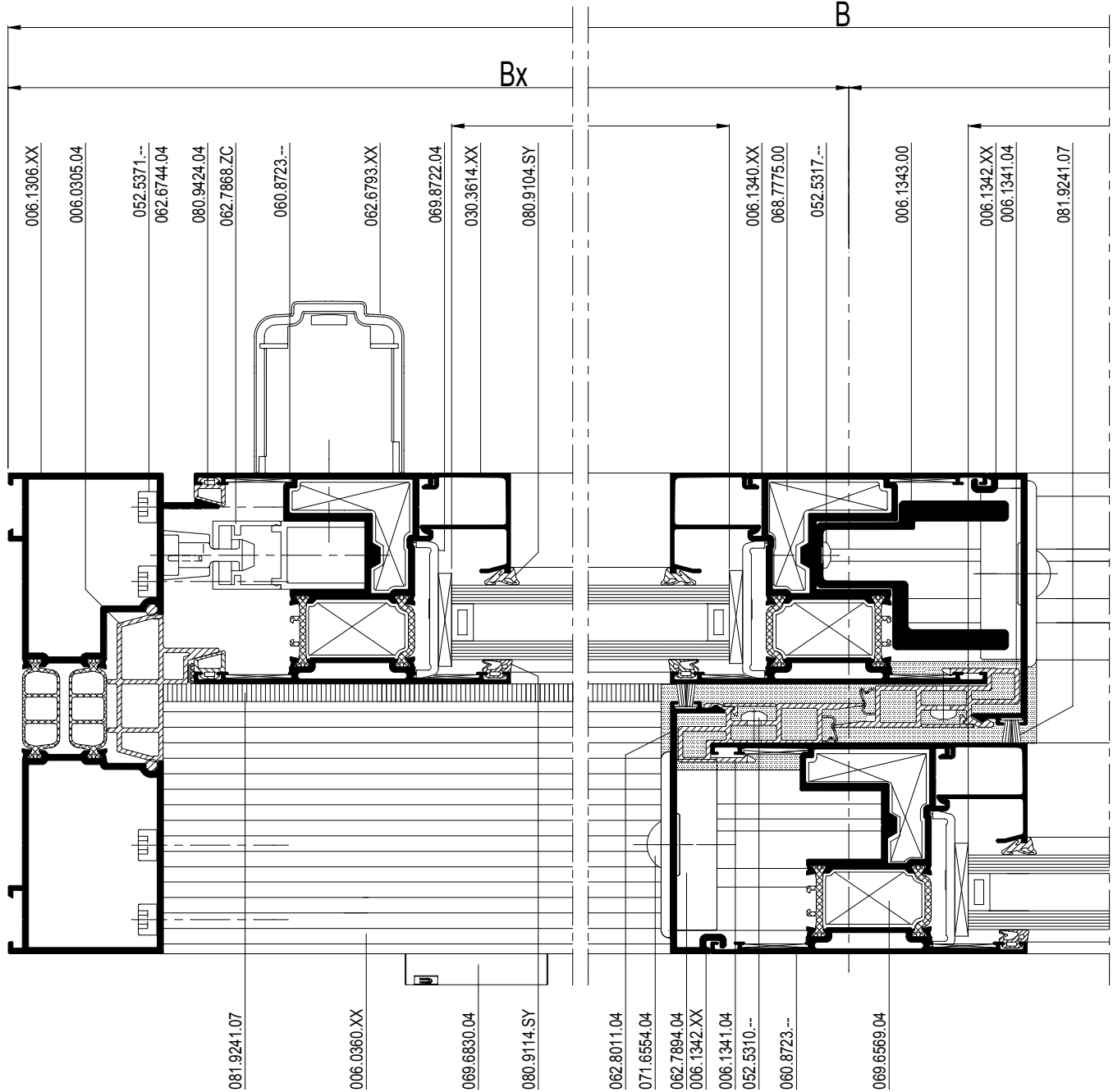

D0059817

CP 155-LS

AUTOMATISCHE HEFSCHUIFDEUR
 SOULEV. COULISSANT AUTOMATIQUE
 AUTOMATIC LIFT AND SLIDING DOOR
 AUTOMATISCHE HEBESCHIEBETUER



		or		or	
	---	or	---	or	097.0436.00
	---	or	---	or	097.0437.00

		or	
	095.A700.00	or	095.B300.00
	095.A730.00		095.B323.00

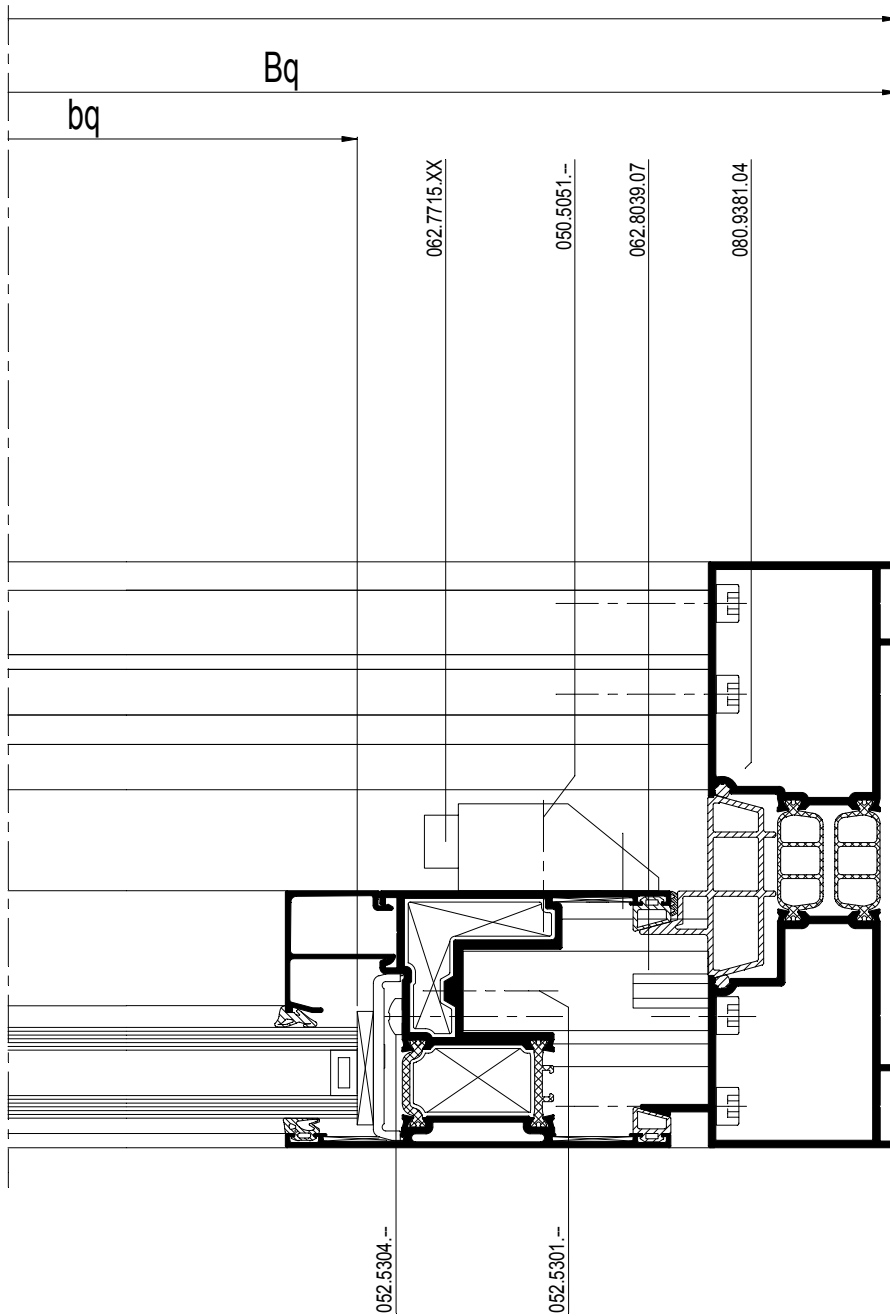

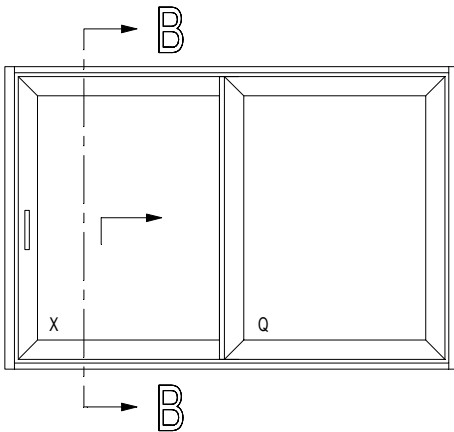

	bx = Bx-181.5
	hx = H-280
	bq = Bq-181.5
	hq = H-280

			#	$\leftarrow L_m \rightarrow$	
006.1300.XX 006.1301.04			1	B-100	34.C....
011.4631.--			1	B-100	34.C....
006.1302.XX			1	B-100	34.C....
006.1303.04			1	B-100	34.C....
006.1306.XX			2	H	34.C....
006.0305.04			2	H-150	34.C....
006.1340.XX			2	Bx-15.5	34.C....
			2	Bq-15.5	
			4	H-114	
006.1342.XX			2	H-114	34.C....
006.1341.04			2	H-114	34.C....
006.1343.00			1	H-173	34.C....
030.3614.XX			2	Bx-169.5	34.C....
			2	Bq-169.5	
			4	H-318	
006.0360.XX			1	Bx-110.5	34.C....
(A) 0M0.1505.XX			1	Bx-678.5	34.C....
(B) 0M0.1505.XX			2	40	34.C....
			1	Bx-1334.5	34.C....
006.0365.XX			1	B-120	34.C....

062.6790.SY		1	34.G....
062.6793.XX		1	

			#	
	052.5371.--		16	34.G....
	062.9396.--		2	34.G....
	068.7775.00		8	34.G....
	069.6569.04		8	34.G....
	060.8723.--		24	34.G....
	062.7894.04		2	34.G....
	052.5317.--		4	34.G....
	071.6554.XX		4	34.G....
(A)	062.7867.--		1	34.G....
(B)	062.7867.--		1	34.G....
	062.7903.--		1	34.G....
(*)	062.7902.ZC		1	34.G....
	062.7868.ZC		1	34.G....
	062.7864.XX		1	34.G....
	061.7038.--		1	34.G....
(A)	062.7715.XX		1	34.G....
	050.5051.--		1	34.G....
(B)	062.7715.XX		2	34.G....
	050.5051.--		2	34.G....
	062.6744.04		2	34.G....
	053.5412.--		2	34.G....
	062.8038.07		3	34.G....
	052.5301.--		3	34.G....
	062.8039.07		3	34.G....
	052.5301.--		3	34.G....
	052.5304.--		6	34.G....
	062.8045.04		2	34.G....
	062.8011.04		1	34.G....
	062.8036.04		1	34.G....
	053.5317.--		2	34.G....
	052.5310.--		2xH (3/m)	34.G....
	052.5317.--		H (3/m)	34.G....
	062.9375.04		2	34.G....
(A)	069.8722.04		16 (-250KG)	34.G....
(A)	069.8722.04		12 (+250KG)	34.G....
	069.8724.04		4	34.G....
(B)	069.8722.04		12	34.G....
	069.8724.04		8	34.G....
	062.6857.04		1	34.G....
	069.6830.04		min. 2	34.G....
	069.6747.04		3	34.G....
	080.9104.SY		(2xB)+(4xH)	34.G....
	080.9114.SY		(2xB)+(4xH)	34.G....
	080.9381.04		(2xB)+(4xH)	34.G....
	080.9424.04		(4xB)+(4xH)	34.G....
	081.9241.07		(2xH)+(Bx)	34.G....

HOOGTE HAUTEUR HEIGHT HOEHE	MIN. 1895 MM
--------------------------------------	--------------

B - B

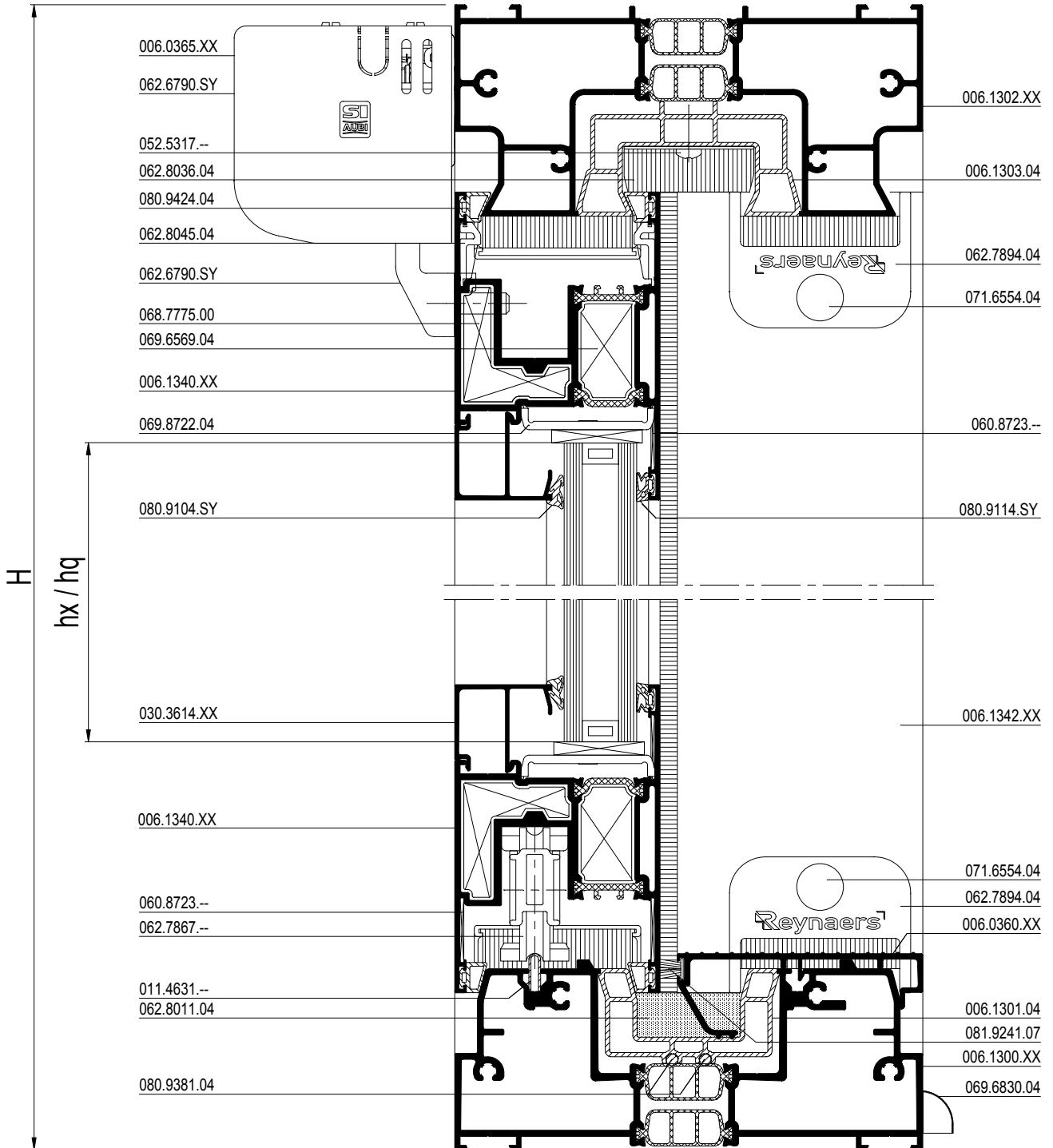

(*) Afhankelijk van de hoogte
 Dépend de l'hauteur
 Dependent of the height
 Von der Höhe abhängig

(A)	VLEUGELGEWICHT POIDS DU VANTAIL WEIGHT OF THE VENT FLÜGELGEWICHT	MAX. 300KG	(B)	VLEUGELGEWICHT POIDS DU VANTAIL WEIGHT OF THE VENT FLÜGELGEWICHT	MIN. 300KG MAX. 400KG

CP 155-LS

AUTOMATISCHE HEFSCHUIFDEUR
SOULEV. COULISSANT AUTOMATIQUE
AUTOMATIC LIFT AND SLIDING DOOR
AUTOMATISCHE HEBESCHIEBETUER



F

Montagetekeningen

Fabrication et montage

Assembly drawings

Montagezeichnungen

CP 155

HOEKVERBINDING
EQUERRE
CORNER CLEAT
ECKVERBINDER



095.30PN.00

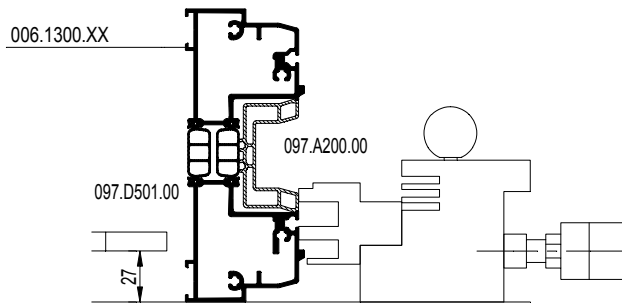
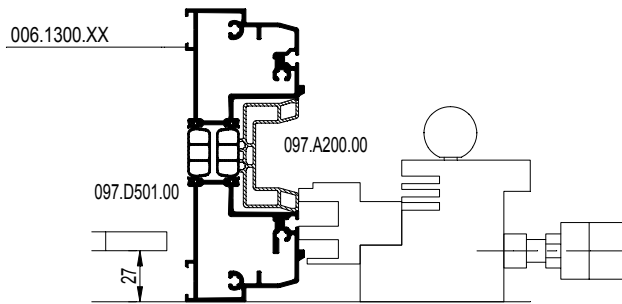

095.B500.00

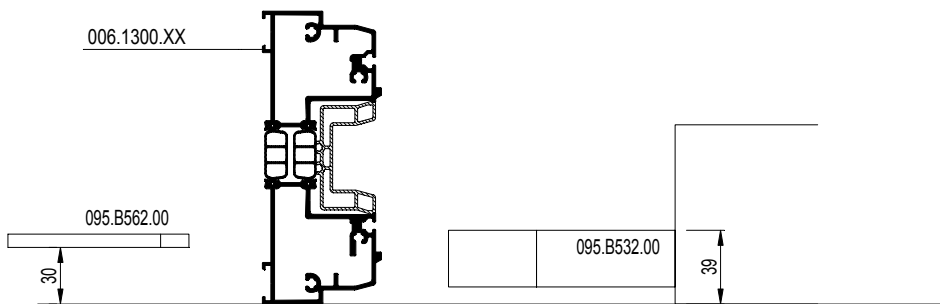
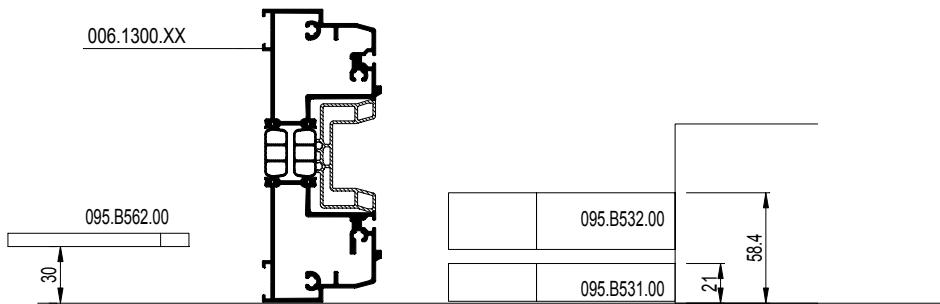

Pershoeken

VOLGORDE

1. Correct zagen
2. Ontbramen (indien noodzakelijk)
3. Stof en zaagresten verwijderen
4. Ontvetten met Degreaser, art. nr. 086.9182.--
5. Anticorrosieproduct aanbrengen, art. nr. 086.9610.--
6. Afdichten op de zaagsnedes door middel van een neutraal, elastisch dichtingsmiddel
7. Verlijmen in de profielkamer door middel van tweekomponentenlijm, art. nr. 084.9070.--
8. Verbinding tot stand brengen en persen
9. Zichtvlakken reinigen met Reynaclean, art. nr. 086.9203.--

Equerres à serrer

ORDRE

1. Tronçonnage correct
2. Ebavurage (si nécessaire)
3. Enlèvement de poussières et de copeaux de sciage
4. Dégraissage avec Degreaser, art. n° 086.9182.--
5. Application du produit anti-corrosion, art. n° 086.9610.--
6. Etanchement des coupes au moyen d'une matière d'étanchéité neutre, élastique
7. Encollage dans la chambre du profilé au moyen de colle bicomposants, art. n° 084.9070.--
8. Assemblage et sertissage
9. Nettoyage des surfaces visibles au moyen de Reynaclean, art. n° 086.9203.--

Crimp corner cleats

SEQUENCE

1. Correct sawing
2. Deburring (if necessary)
3. Removing dust and saw-dust
4. Degreasing with Degreaser, art. no 086.9182.--
5. Applying anti-corrosion product, art. no 086.9610.--
6. Sealing on the saw cuts by means of a neutral, elastic sealing agent
7. Glueing in the profile chamber by means of glue for corner connections, art. no. 084.9070.--
8. Assembly and crimping
9. Cleaning visible surfaces by means of Reynaclean art. no. 086.9203.--

Presseckwinkel

REIHENFOLGE

1. Zuschneiden
2. Entgraten (falls erforderlich)
3. Staub und Sägereste entfernen
4. Entfetten mit Degreaser, Art. nr. 086.9182.--
5. Korrosionsschutzprodukt aufbringen, Art. nr. 086.9610.--
6. Die Schnittflächen mit einer neutralen, elastischen Dichtungsmasse versehen
7. Klebereinsatz in die Eckwinkelkammer mit Zweikomponentenkleber, Art. nr. 084.9070.--
8. Verbinden und verpressen
9. Die Sichtseiten säubern mit Reynaclean, Art. nr. 086.9203.--

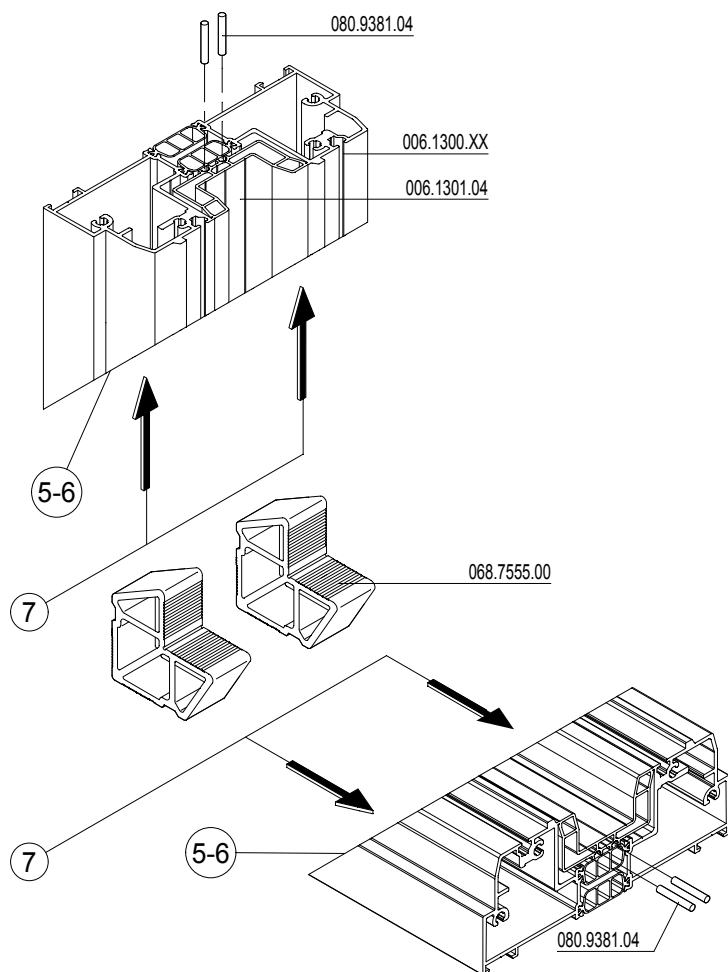

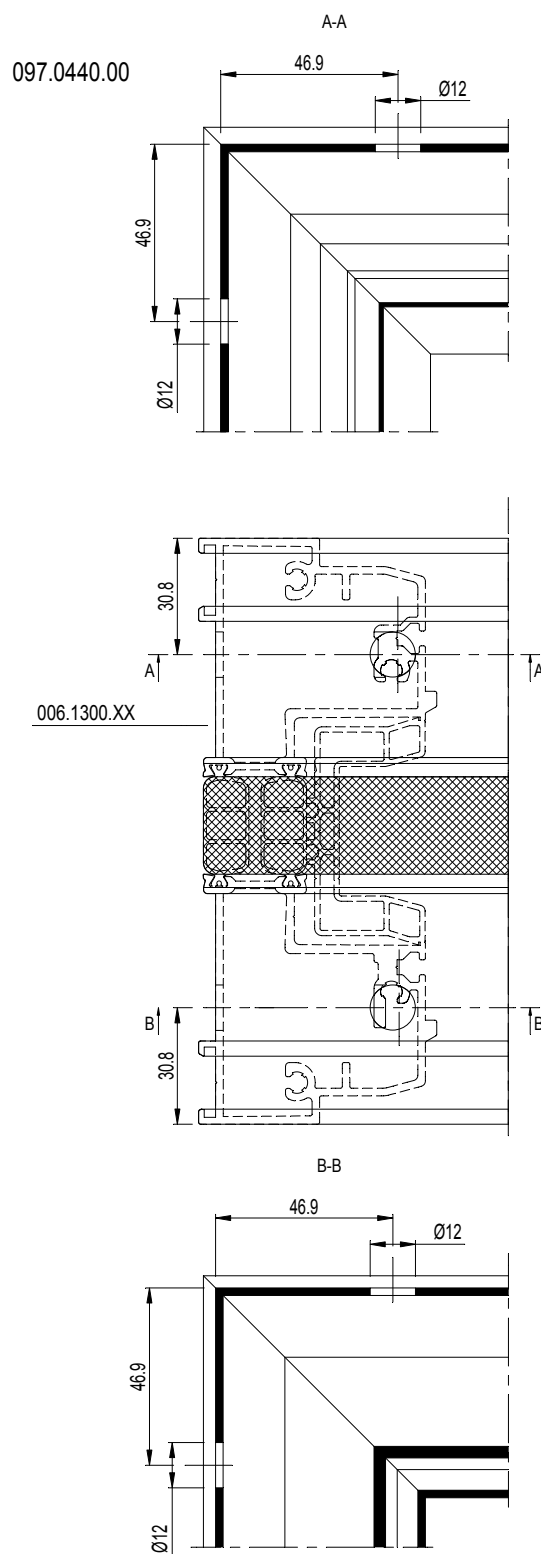

Schroefhoeken

VOLGORDE

1. Correct zagen
2. Ontbramen (indien noodzakelijk)
3. Stof en zaagresten verwijderen
4. Ontvetten met Degreaser, art. nr. 086.9182.--
5. Anticorrosieproduct aanbrengen, art. nr. 086.9610.--
6. Afdichten op de zaagsnedes door middel van een neutraal, elastisch dichtingsmiddel
7. Verlijmen in de profielkamer door middel van tweekomponentenlijm, art. nr. 084.9070.--
8. Verbinding tot stand brengen en schroeven
9. Zichtvlakken reinigen met Reynaclean, art. nr. 086.9203.--

Equerres à blocage

ORDRE

1. Tronçonnage correct
2. Ebavurage (si nécessaire)
3. Enlèvement de poussières et de copeaux de sciage
4. Dégraissage avec Degreaser, art. n° 086.9182.--
5. Application du produit anti-corrosion, art. n° 086.9610.--
6. Etanchement des coupes au moyen d'une matière d'étanchéité neutre, élastique
7. Encollage dans la chambre du profilé au moyen de colle bicomposants, art. n° 084.9070.--
8. Assemblage et vissage
9. Nettoyage des surfaces visibles au moyen de Reynaclean, art. n° 086.9203.--

Screw corner cleats

SEQUENCE

1. Correct sawing
2. Deburring (if necessary)
3. Removing dust and saw-dust
4. Degreasing with Degreaser, art. no 086.9182.--
5. Applying anti-corrosion product, art. no 086.9610.--
6. Sealing on the saw cuts by means of a neutral, elastic sealing agent
7. Glueing in the profile chamber by means of glue for corner connections, art. no. 084.9070.--
8. Assembly and screwing
9. Cleaning visible surfaces by means of Reynaclean art. no. 086.9203.--

Schraubeckwinkel

REIHENFOLGE

1. Zuschneiden
2. Entgraten (falls erforderlich)
3. Staub und Sägereste entfernen
4. Entfetten mit Degreaser, Art. nr. 086.9182.--
5. Korrosionsschutzprodukt aufbringen, Art. nr. 086.9610.--
6. Die Schnittflächen mit einer neutralen, elastischen Dichtungsmasse versehen
7. Klebereinsatz in die Eckwinkelkammer mit Zweikomponentenkleber, Art. nr. 084.9070.--
8. Verbinden und verschrauben
9. Die Sichtseiten säubern mit Reynaclean, Art. nr. 086.9203.--

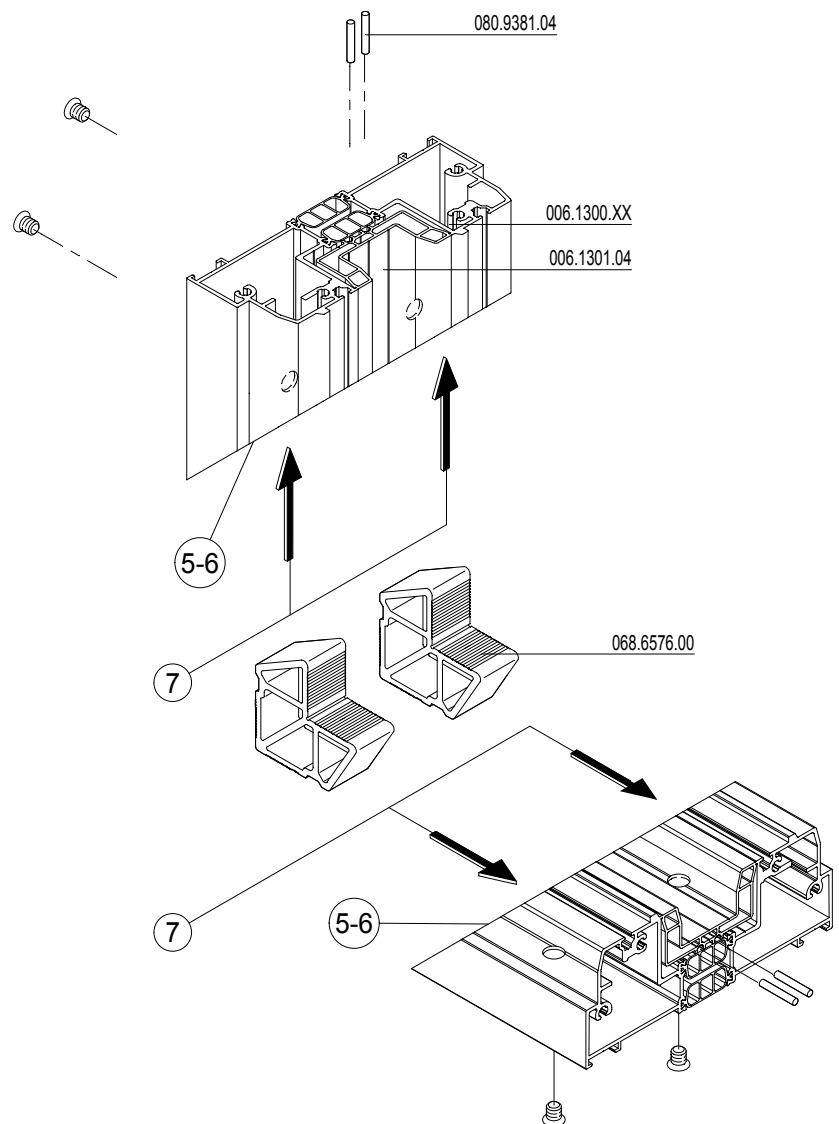

095.30PN.00

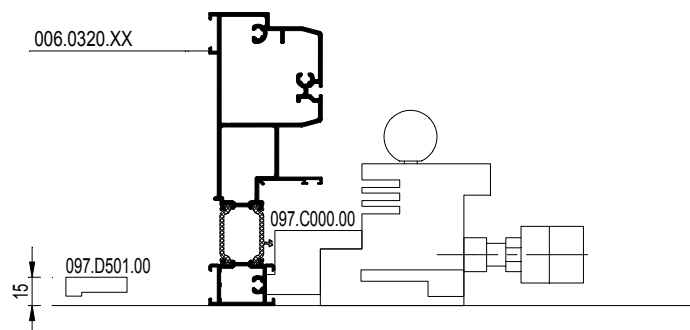
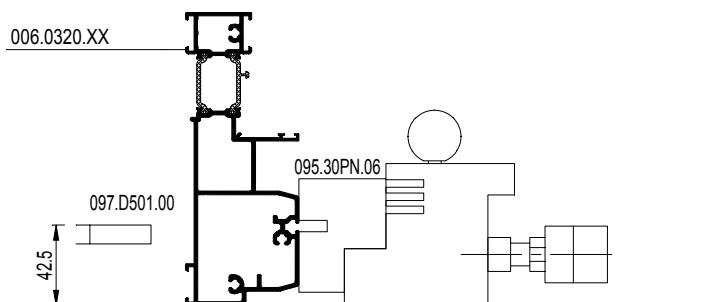

095.B500.00

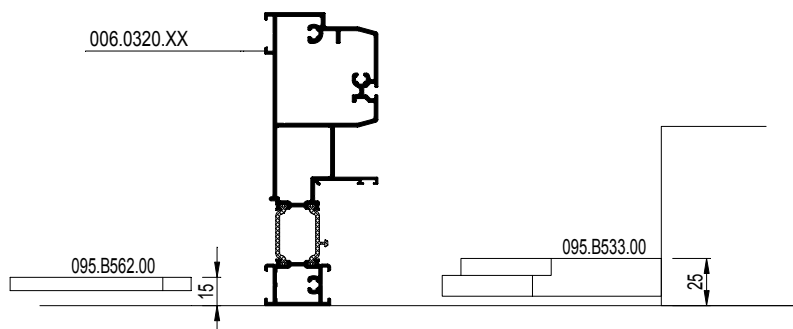
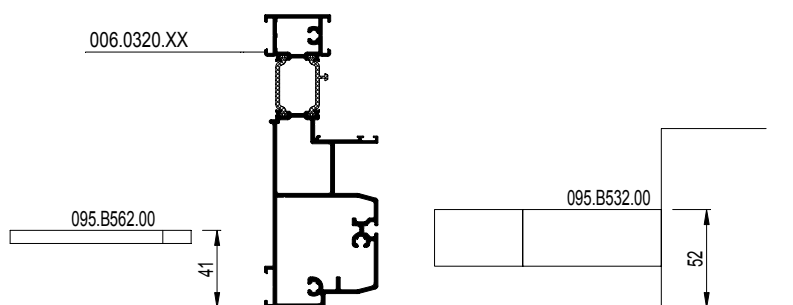

Pershoeken

VOLGORDE

1. Correct zagen
2. Ontbramen (indien noodzakelijk)
3. Stof en zaagresten verwijderen
4. Ontvetten met Degreaser, art. nr. 086.9182.--
5. Anticorrosieproduct aanbrengen, art. nr. 086.9610.--
6. Afdichten op de zaagsnedes door middel van een neutraal, elastisch dichtingsmiddel
7. Verflijmen: - in de profielkamer
- op de plaats waar de steunhoek komt
door middel van tweekomponentenlijm, art. nr. 084.9070.--
8. Verbinding tot stand brengen en persen
9. Zichtvlakken reinigen met Reynaclean, art. nr. 086.9203.--

Equerres à serrer

ORDRE

1. Tronçonnage correct
2. Ebavurage (si nécessaire)
3. Enlèvement de poussières et de copeaux de sciage
4. Dégraissage avec Degreaser, art. n° 086.9182.--
5. Application du produit anti-corrosion, art. n° 086.9610.--
6. Etanchement des coupes au moyen d'une matière d'étanchéité neutre, élastique
7. Encollage: - dans la chambre du profilé
- dans la rainure destinée à la cale de feuillure
au moyen de colle bicomposants, art. n° 084.9070.--
8. Assemblage et sertissage
9. Nettoyage des surfaces visibles au moyen de Reynaclean, art. n° 086.9203.--

Crimp corner cleats

SEQUENCE

1. Correct sawing
2. Deburring (if necessary)
3. Removing dust and saw-dust
4. Degreasing with Degreaser, art. no 086.9182.--
5. Applying anti-corrosion product, art. no 086.9610.--
6. Sealing on the saw cuts by means of a neutral, elastic sealing agent
7. Glueing: - in the profile chamber
- in the area where the rebate support will be inserted
by means of glue for corner connections, art. no. 084.9070.--
8. Assembly and crimping
9. Cleaning visible surfaces by means of Reynaclean art. no. 086.9203.--

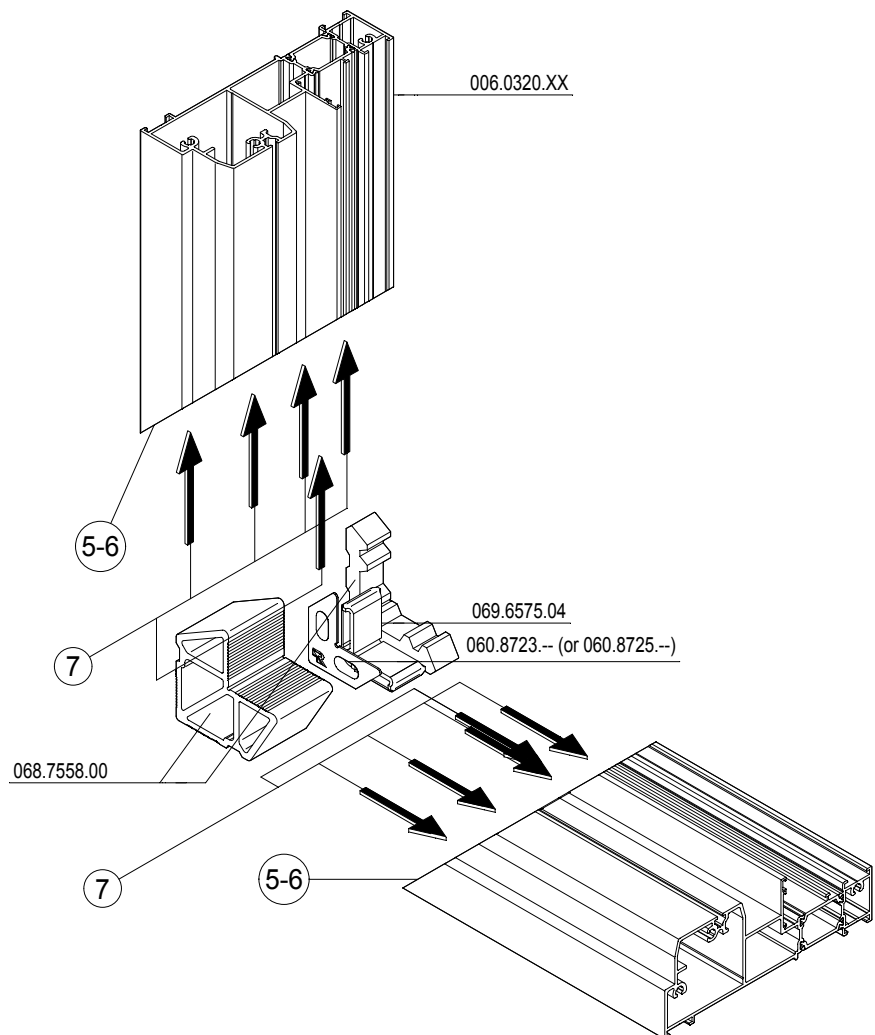

Presseckwinkel

REIHENFOLGE

1. Zuschneiden
2. Entgraten (falls erforderlich)
3. Staub und Sägereste entfernen
4. Entfetten mit Degreaser, Art. nr. 086.9182.--
5. Korrosionsschutzprodukt aufbringen, Art. nr. 086.9610.--
6. Die Schnittflächen mit einer neutralen, elastischen Dichtungsmasse versehen
7. Klebereinsatz: - in die Eckwinkelkammer
- im Bereich des Glasanschlagwinkels
mit Zweikomponentenkleber, Art. nr. 084.9070.--
8. Verbinden und verpressen
9. Die Sichtseiten säubern mit Reynaclean, Art. nr. 086.9203.--

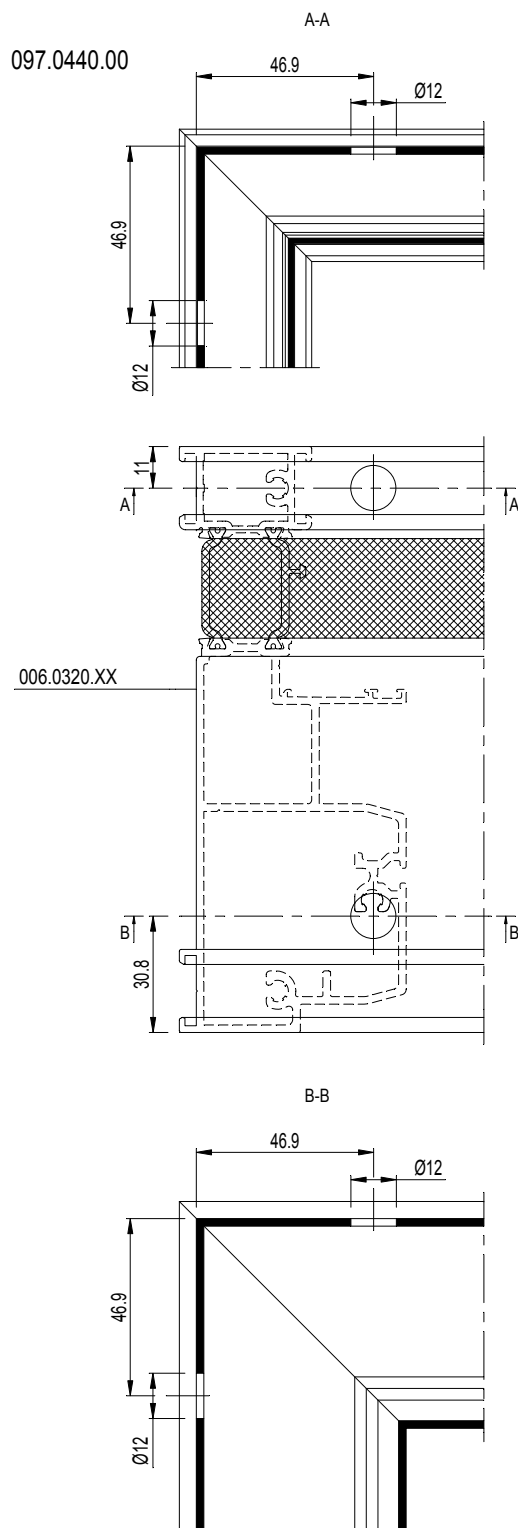

Schroefhoeken

VOLGORDE

1. Correct zagen
2. Ontbramen (indien noodzakelijk)
3. Stof en zaagresten verwijderen
4. Ontvetten met Degreaser, art. nr. 086.9182.--
5. Anticorrosieproduct aanbrengen, art. nr. 086.9610.--
6. Afdichten op de zaagsnedes door middel van een neutraal, elastisch dichtingsmiddel
7. Verlijmen: - in de profielkamer
 - op de plaats waar de steunhoek komt
 door middel van tweekomponentenlijm, art. nr. 084.9070.--
8. Verbinding tot stand brengen en schroeven
9. Zichtvlakken reinigen met Reynaclean, art. nr. 086.9203.--

Equerres à blocage

ORDRE

1. Tronçonnage correct
2. Ebavurage (si nécessaire)
3. Enlèvement de poussières et de copeaux de sciage
4. Degraissage avec Degreaser, art. n° 086.9182.--
5. Application du produit anti-corrosion, art. n° 086.9610.--
6. Etanchement des coupes au moyen d'une matière d'étanchéité neutre, élastique
7. Encollage: - dans la chambre du profilé
 - dans la rainure destinée à la cale de feuillure
 au moyen de colle bicomposants, art. n° 084.9070.--
8. Assemblage et vissage
9. Nettoyage des surfaces visibles au moyen de Reynaclean, art. n° 086.9203.--

Screw corner cleats

SEQUENCE

1. Correct sawing
2. Deburring (if necessary)
3. Removing dust and saw-dust
4. Degreasing with Degreaser, art. no 086.9182.--
5. Applying anti-corrosion product, art. no 086.9610.--
6. Sealing on the saw cuts by means of a neutral, elastic sealing agent
7. Gluing: - in the profile chamber
 - in the area where the rebate support will be inserted
 by means of glue for corner connections, art. no. 084.9070.--
8. Assembly and screwing
9. Cleaning visible surfaces by means of Reynaclean art. no. 086.9203.--

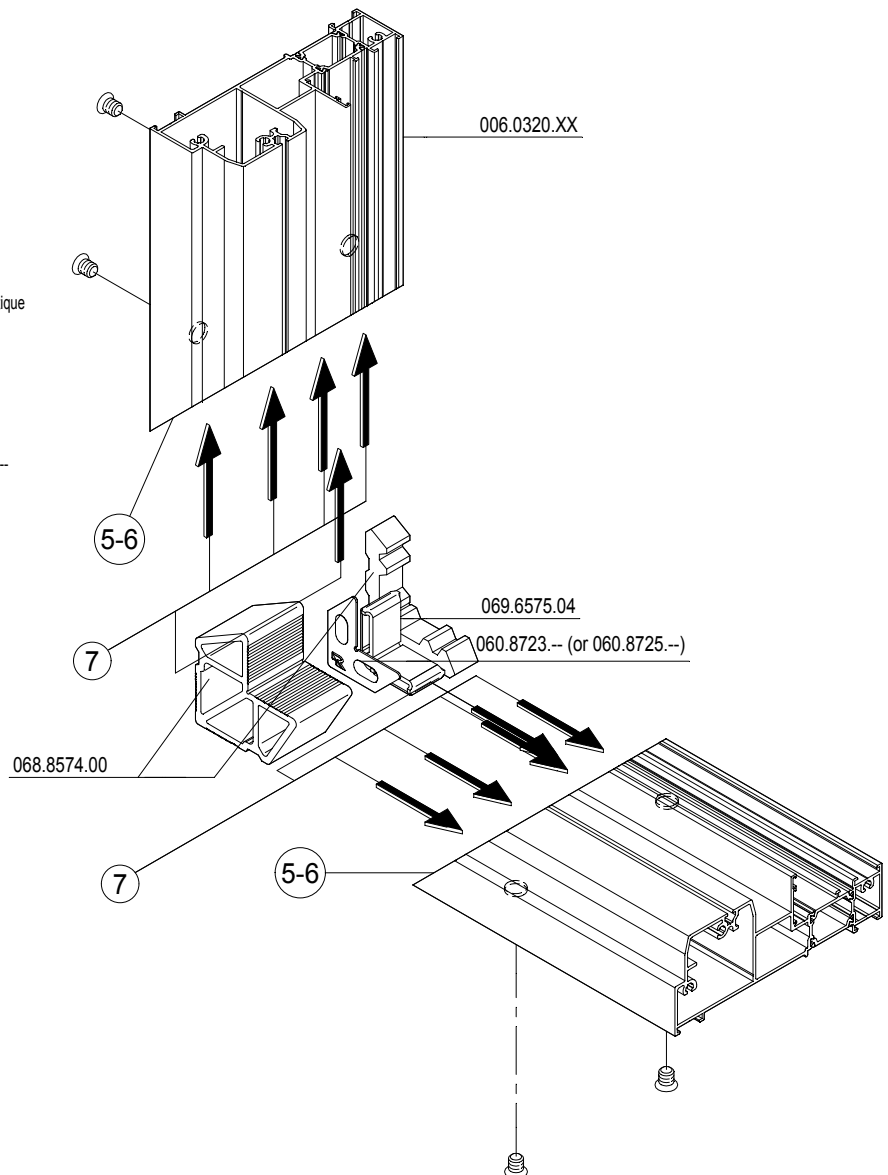

Schraubeckwinkel

REIHENFOLGE

1. Zuschneiden
2. Entgraten (falls erforderlich)
3. Staub und Sägereste entfernen
4. Entfetten mit Degreaser, Art. nr. 086.9182.--
5. Korrosionsschutzprodukt aufbringen, Art. nr. 086.9610.--
6. Die Schnittflächen mit einer neutralen, elastischen Dichtungsmasse versehen
7. Klebereinsatz: - in die Eckwinkelkammer
 - im Bereich des Glasanschlagwinkels
 mit Zweikomponentenkleber, Art. nr. 084.9070.--
8. Verbinden und verschrauben
9. Die Sichtseiten säubern mit Reynaclean, Art. nr. 086.9203.--

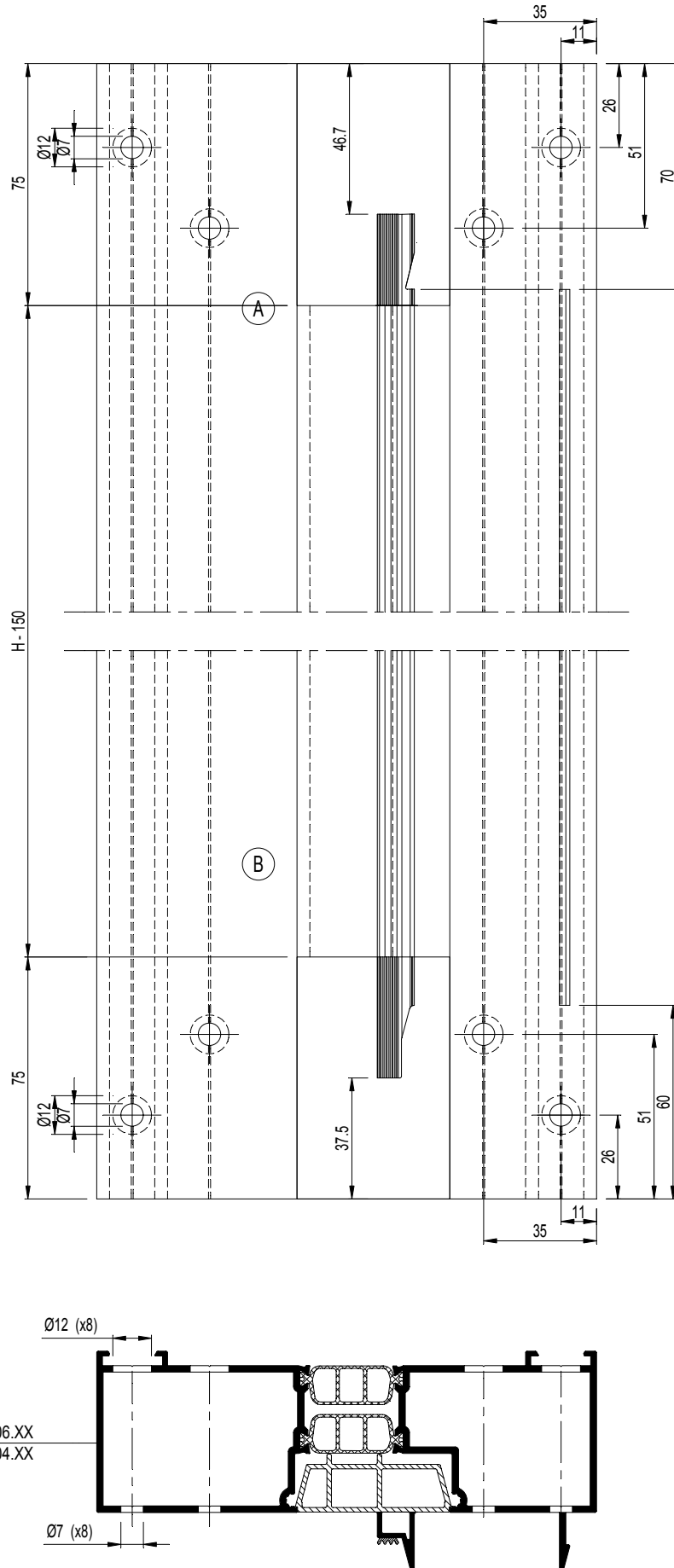

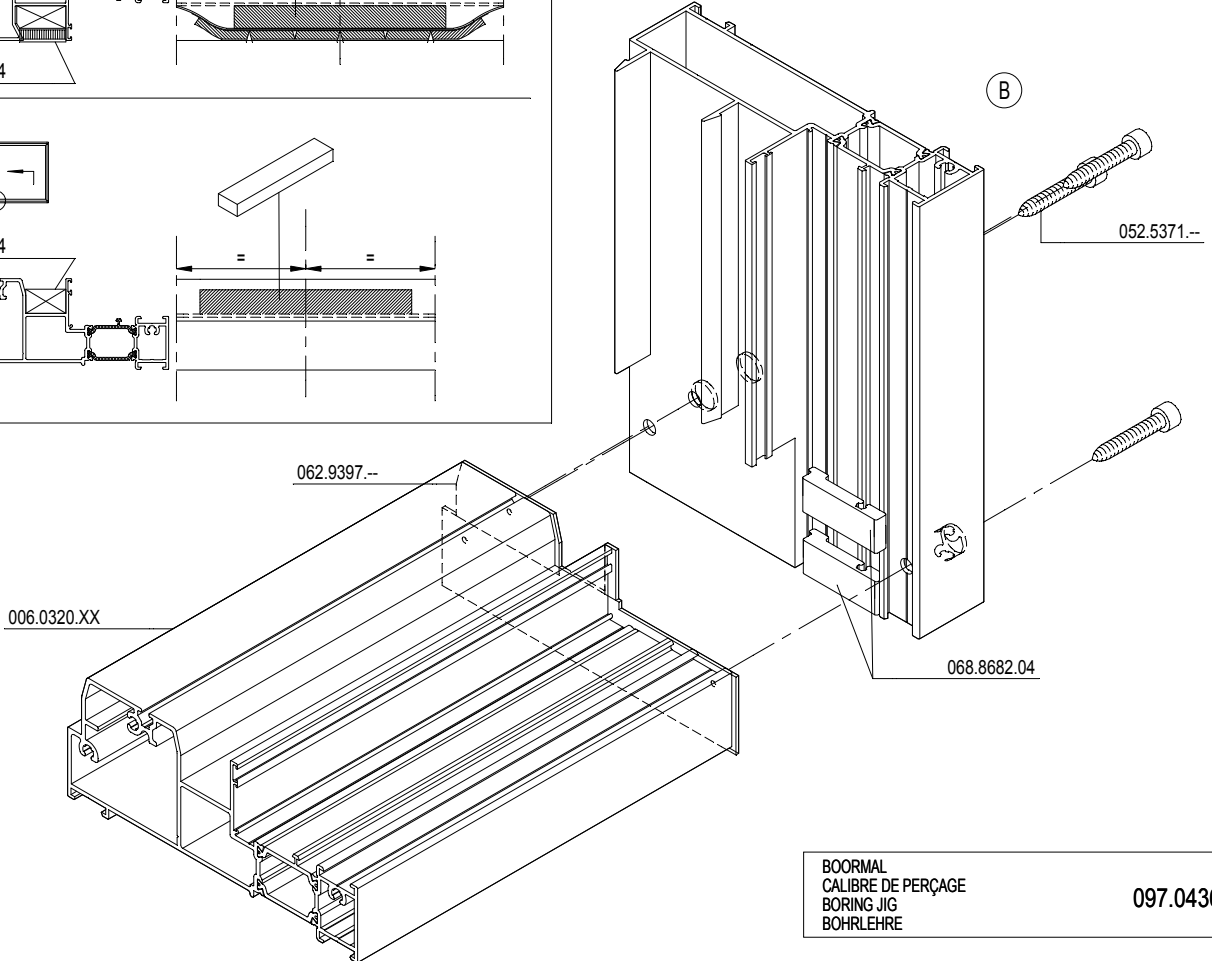
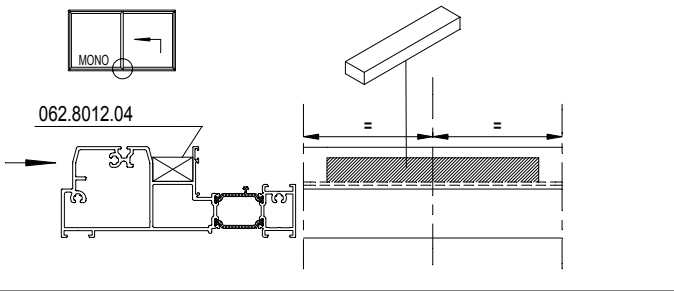
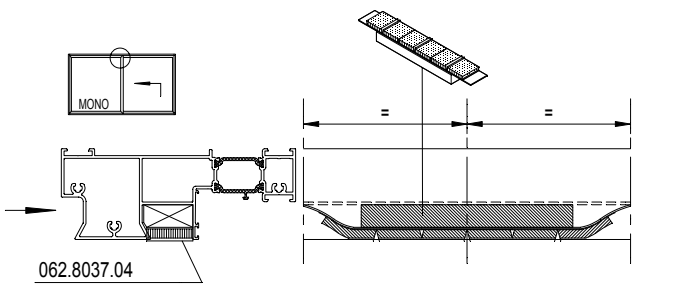
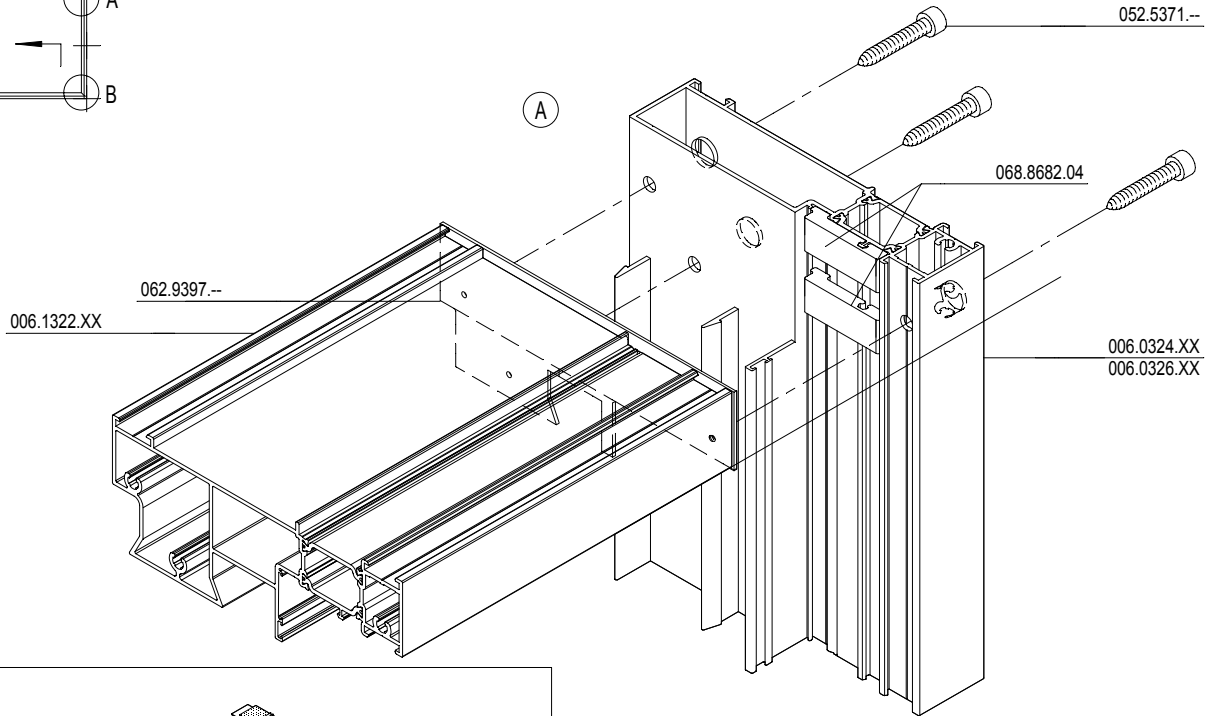
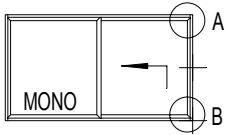

BOORMAL
 CALIBRE DE PERÇAGE
 BORING JIG
 BOHRLEHRE

097.0436.00

D0013956

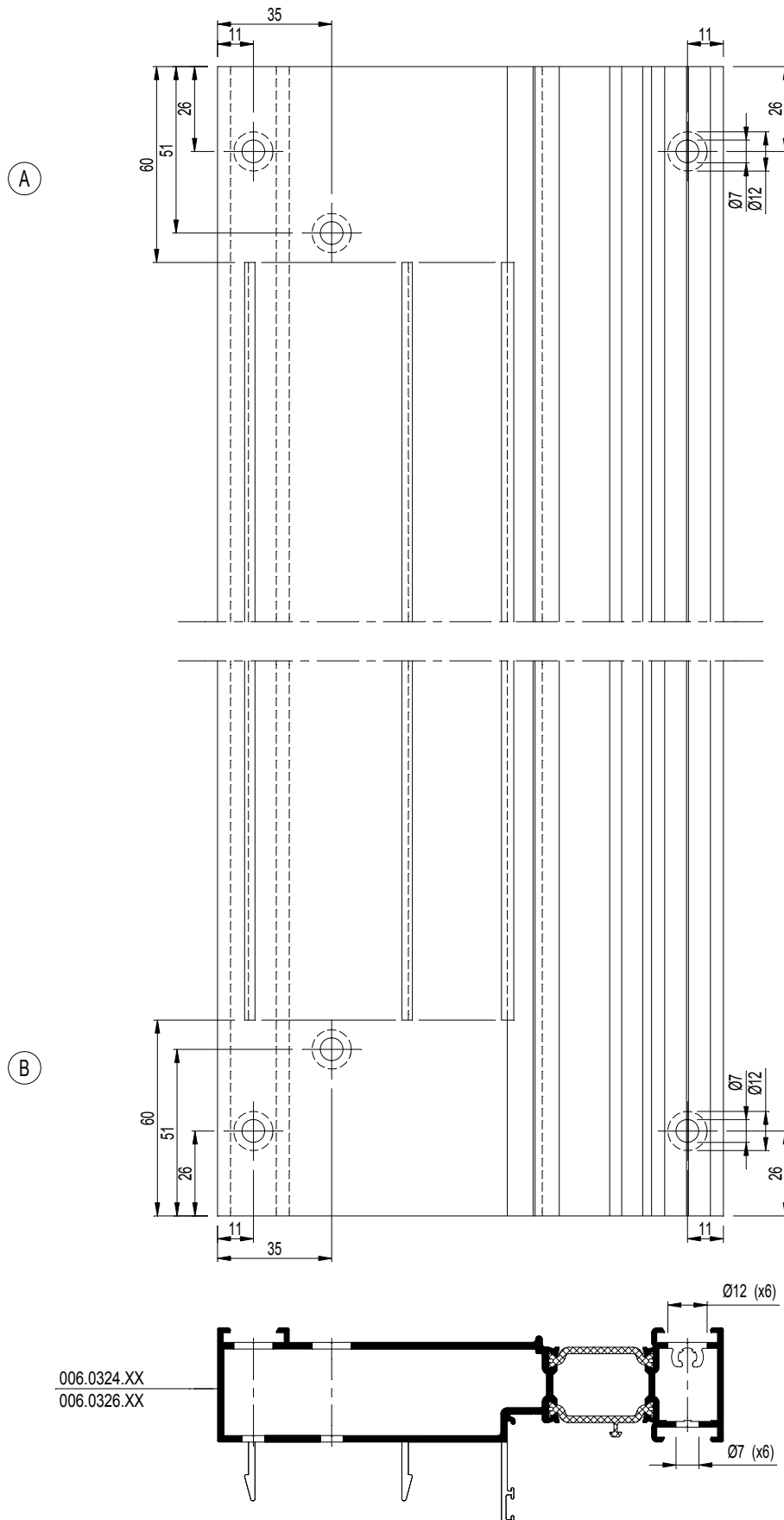

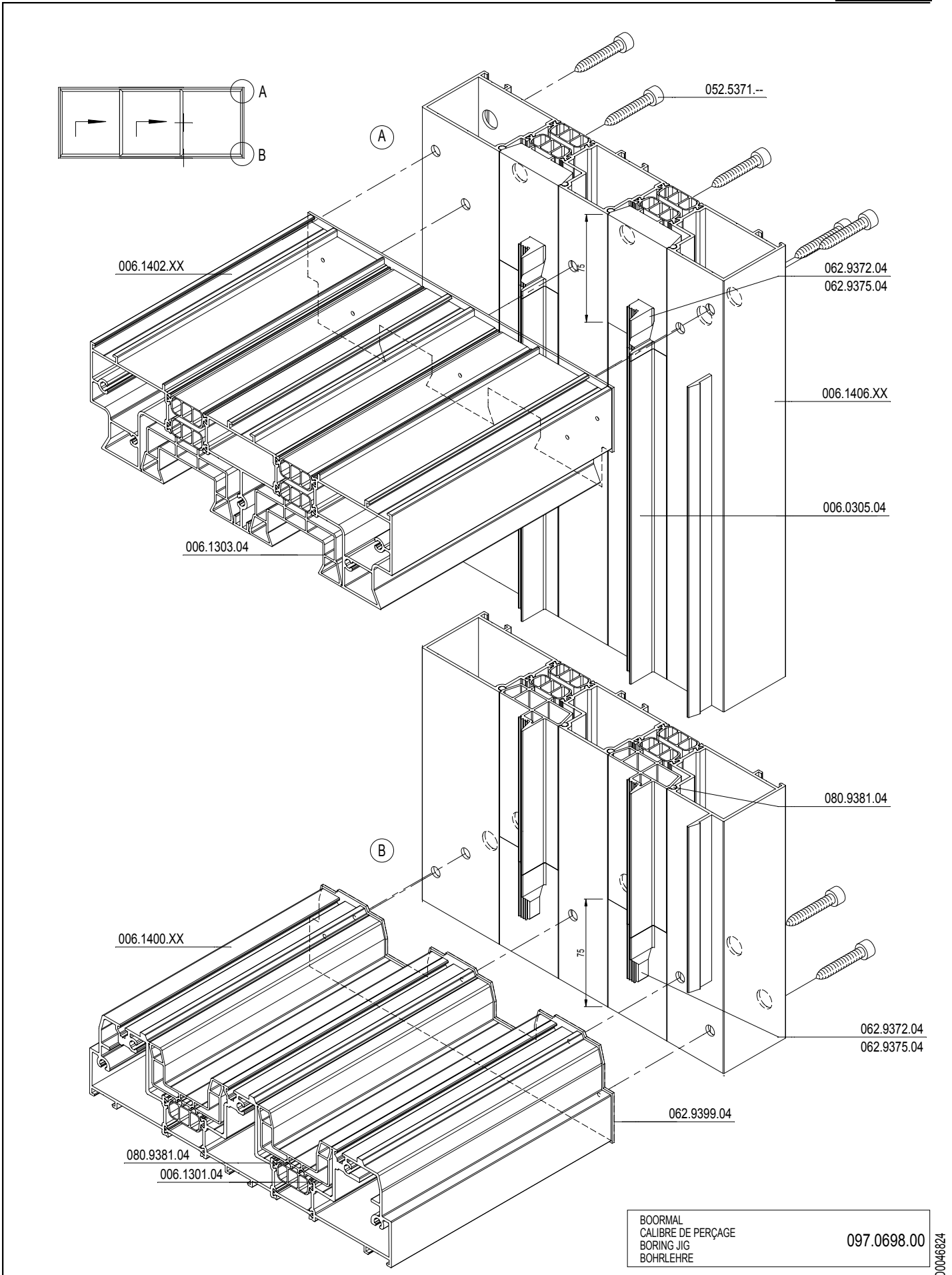

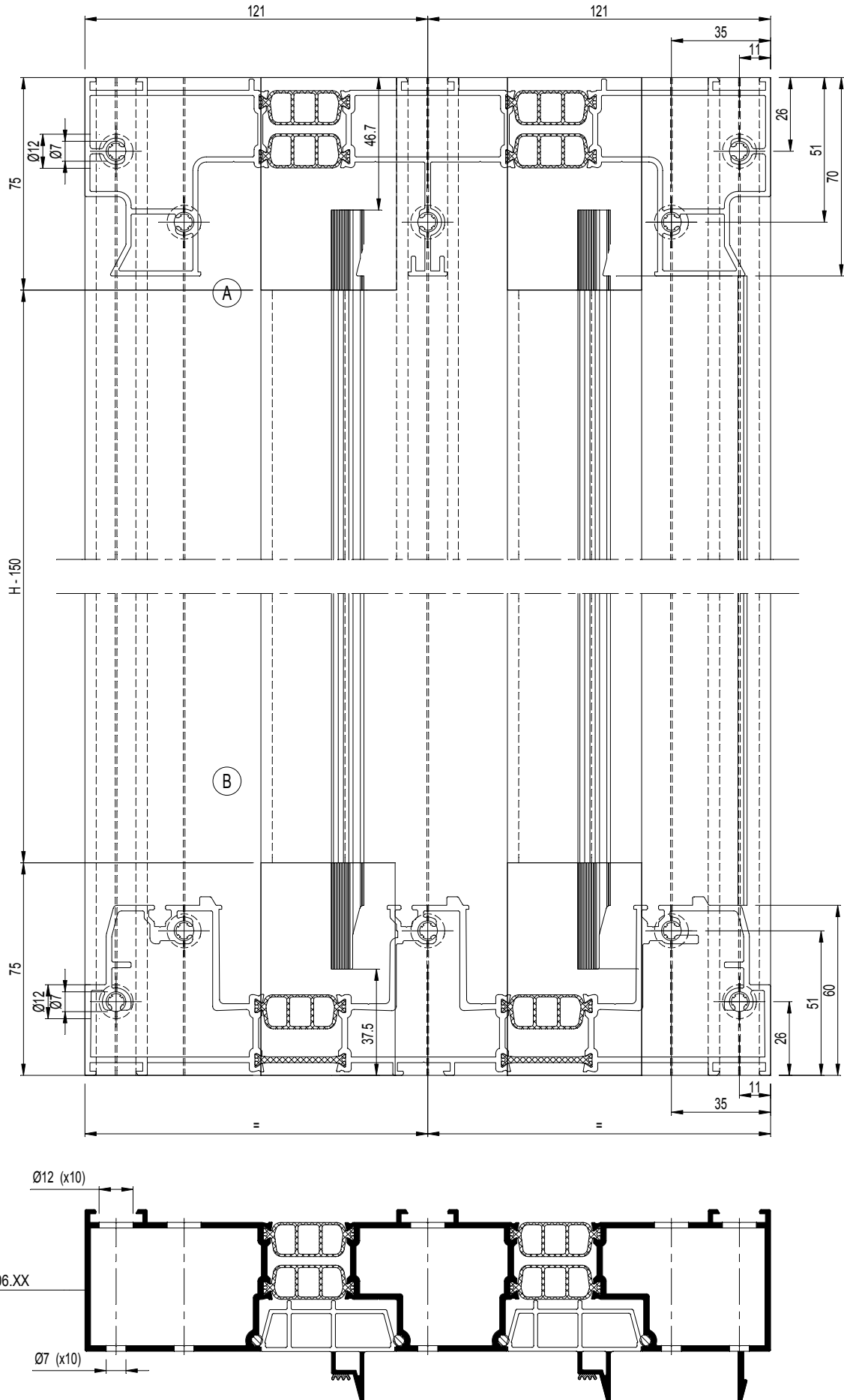

CP 155 CP 155-LS

HOEKVERBINDING VLEUGEL
ASSEMBLAGE ANGULAIRE OUVRANT
CORNER CONNECTION VENT
ECKVERBINDUNG FLUEGEL

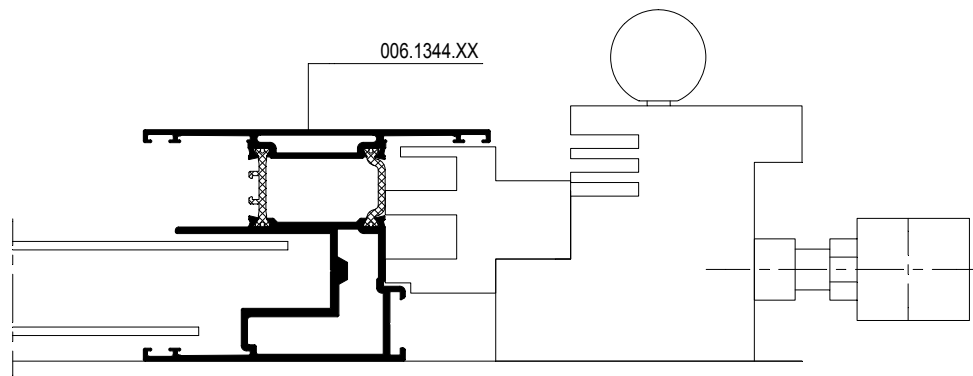
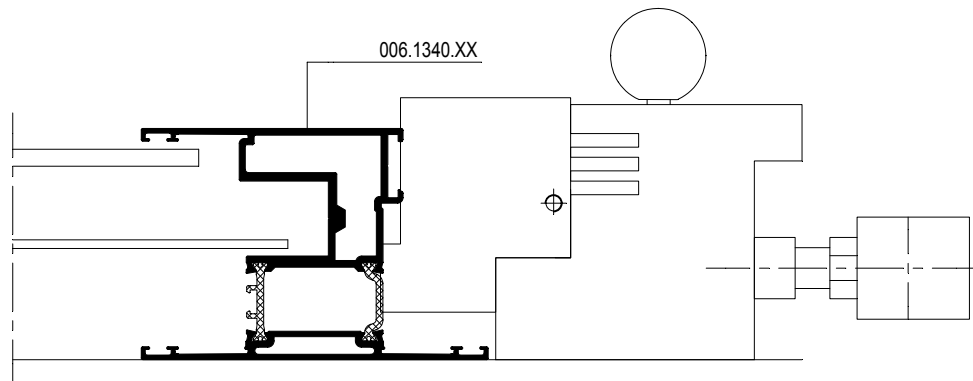
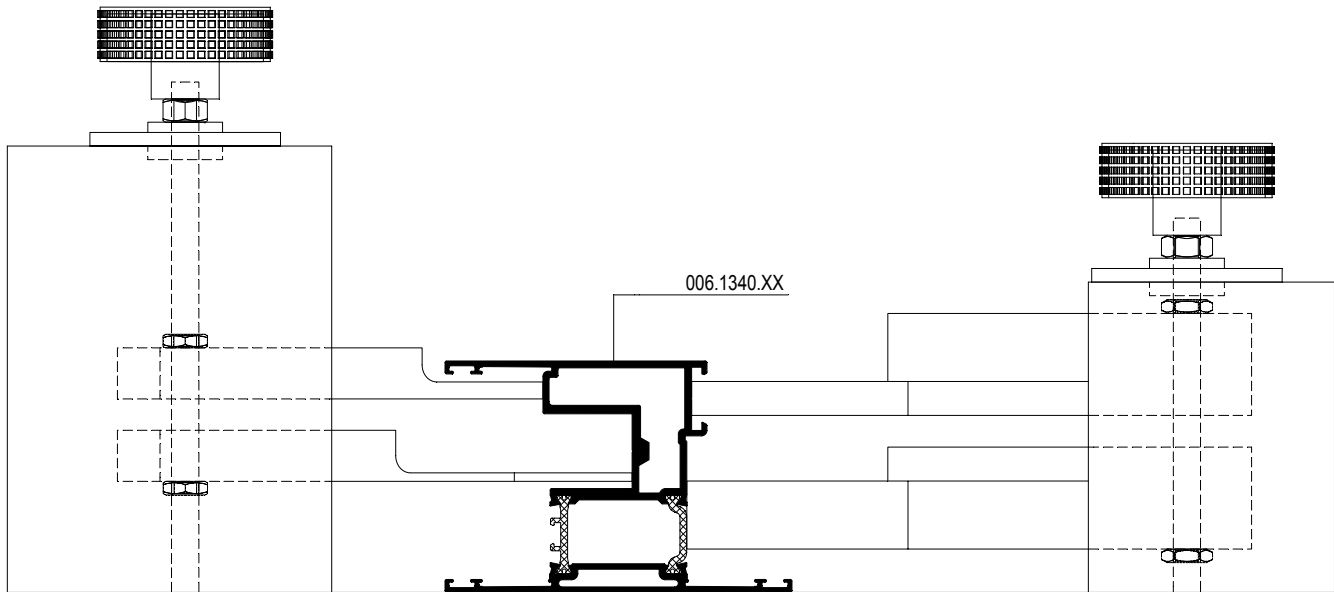

CP 155 CP 155-LS

T-VERBINDINGEN
RACCORDEMENTS-T
T-CONNECTIONS
T-VERBINDUNGEN



T-verbindingen

VOLGORDE

1. Correct zagen, ponsen of boren
2. Ontbramen (indien noodzakelijk)
3. Stof en zaagresten verwijderen
4. Ontvetten met Degreaser, art.nr. 086.9182.--
5. Anticorrosieproduct aanbrengen, art.nr. 086.9610.--
6. Afdichten (x) door middel van een neutraal, elastisch dichtingsmiddel
7. Verbinding tot stand brengen
8. Zichtvlakken reinigen met Reynaclean, art.nr. 086.9203.--

T-Verbinder

REIHENFOLGE

1. Zuschneiden, stanzen oder bohren
2. Entgraten (falls erforderlich)
3. Staub und Sägereste entfernen
4. Entfetten mit Degreaser, Art.-Nr. 086.9182.--
5. Korrosionsschutzprodukt aufbringen, Art.-Nr. 086.9610.--
6. Mit einer neutralen, elastischen Dichtungsmasse abdichten (x)
7. Verbinden
8. Die Sichtseiten säubern mit Reynaclean, Art.-Nr. 086.9203.--

T-brackets

SEQUENCE

1. Correct sawing, punching or drilling
2. Deburring (if necessary)
3. Removing dust and saw-dust
4. Degreasing by means of Degreaser, art.no. 086.9182.--
5. Applying anti-corrosion product, art.no. 086.9610.--
6. Sealing (x) by means of a neutral, elastic sealing agent
7. Making the connection
8. Cleaning visible surfaces by means of Reynaclean, art.no. 086.9203.--

Assemblages T

ORDRE

1. Tronçonnage, poinçonnage ou forage correct
2. Ebavurage (si nécessaire)
3. Enlèvement des poussières et des copeaux de sciage
4. Dégraissage avec Degreaser, art.n° 086.9182.--
5. Application du produit anti-corrosion, art.n° 086.9610.--
6. Etanchement (x) au moyen d'une matière d'étanchéité neutre, élastique
7. Assemblage
8. Nettoyage des surfaces visibles au moyen de Reynaclean, art.n° 086.9203.--

CP 155 CP 155-LS

T-VERBINDER MET SCHROEF
JONCTION-T AVEC VIS
T-BRACKET WITH SCREW
T-VERBINDER MIT SCHRAUBE



MULTIFUNCTIONELE MATRIJS 097.P800.00
MATRICE GUIDEE MULTIFUNCTIONELLE (*) 097.O900.00
MULTIFUNCTIONAL PUNCH TOOL
MEHRZWECKSTANZWERKZEUG 097.P000.00

MULTIFUNCTIONELE MATRIJS 097.P800.00
MATRICE GUIDEE MULTIFUNCTIONELLE (**) 097.P100.00
MULTIFUNCTIONAL PUNCH TOOL
MEHRZWECKSTANZWERKZEUG 097.P200.00

BOORMAL 097.0410.00
CALIBRE DE PERÇAGE
BORING JIG
BOHRLEHRE

GELEIDE MATRIJS (*) 097.F800.00
MATRICE GUIDEE
PUNCH TOOL
STANZWERKZEUG (**) 097.F900.00

(*) 008.3113.XX
(**) 008.1370.XX / 008.3114.XX / 008.3123.XX / 008.3824.XX

T-verbinder enkel horizontaal te gebruiken
Jonction-T seulement pour des applications horizontales
T-bracket only for horizontal use
T-verbinder nur für horizontale Anwendung

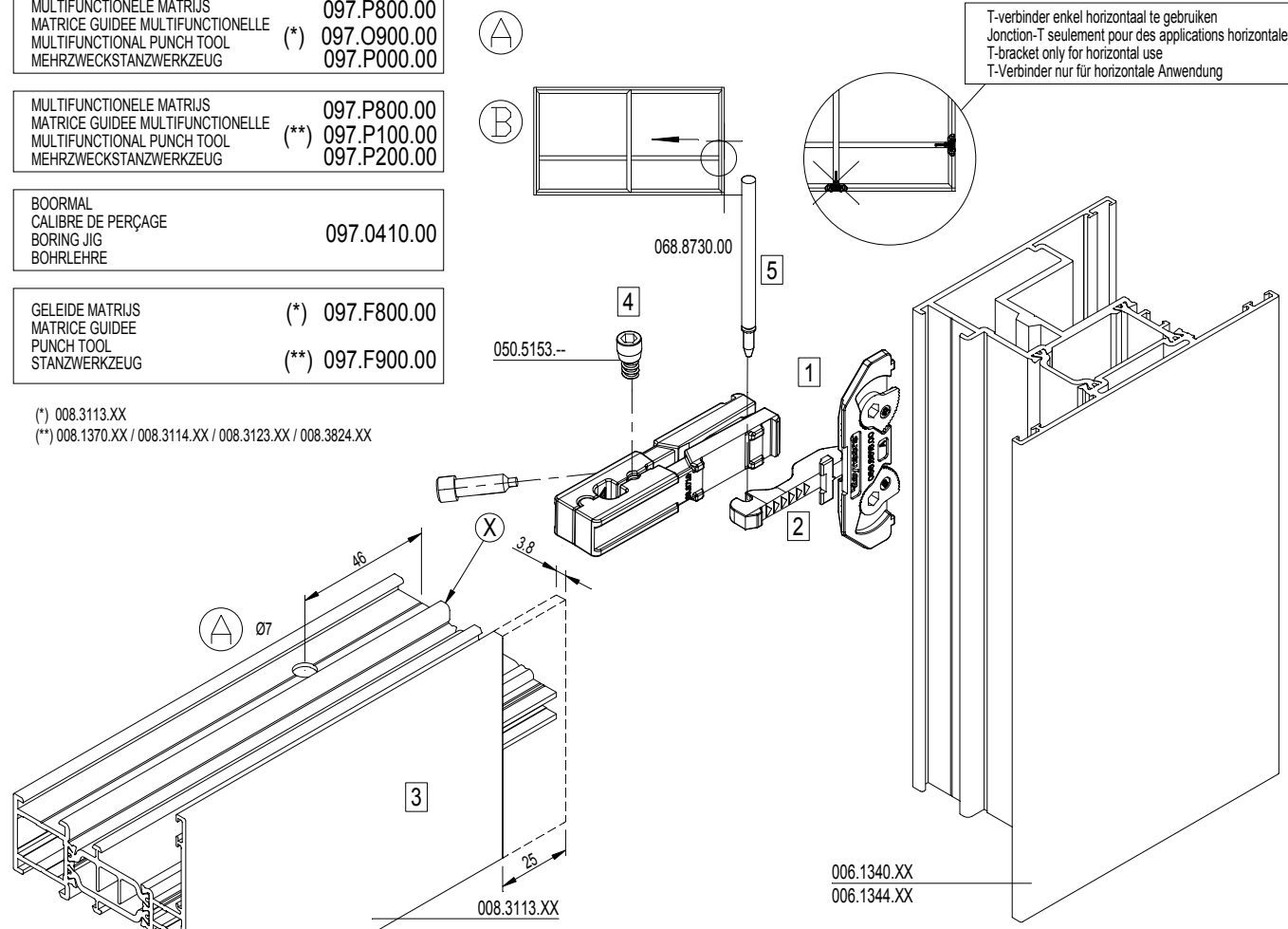

(X) DICHTINGSMIDDEL
MATIERE D'ETANCHEITE
SEALING AGENT
ABDICHTUNG

MONTAGEVOLGORDE
L'ORDRE DE MONTAGE
THE ORDER OF ASSEMBLY
MONTAGEREIHENFOLGE

1	2	3	.
---	---	---	---

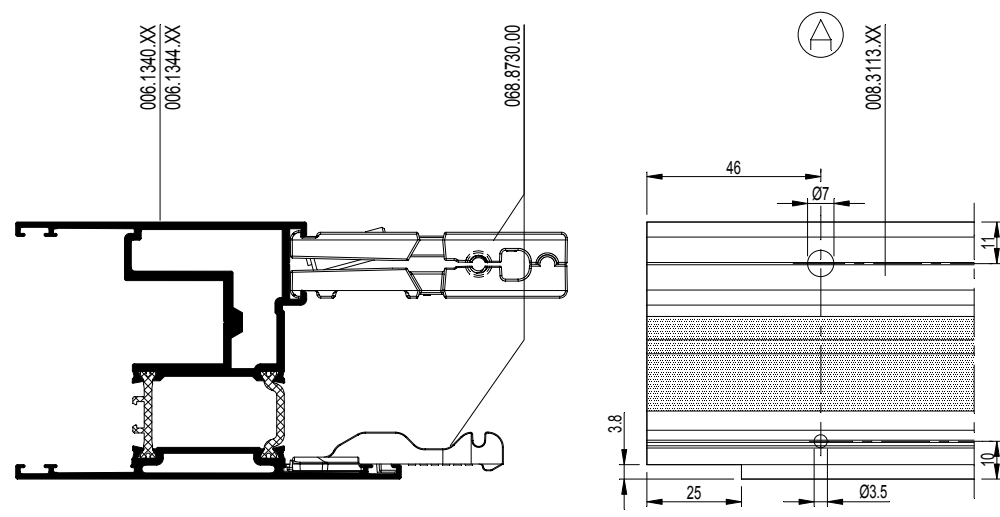

CP 155 CP 155-LS

T-VERBINDER MET NAGEL
JONCTION-T AVEC CHEVILLE
T-BRACKET WITH DRIVE PIN
T-VERBINDER MIT STIFT

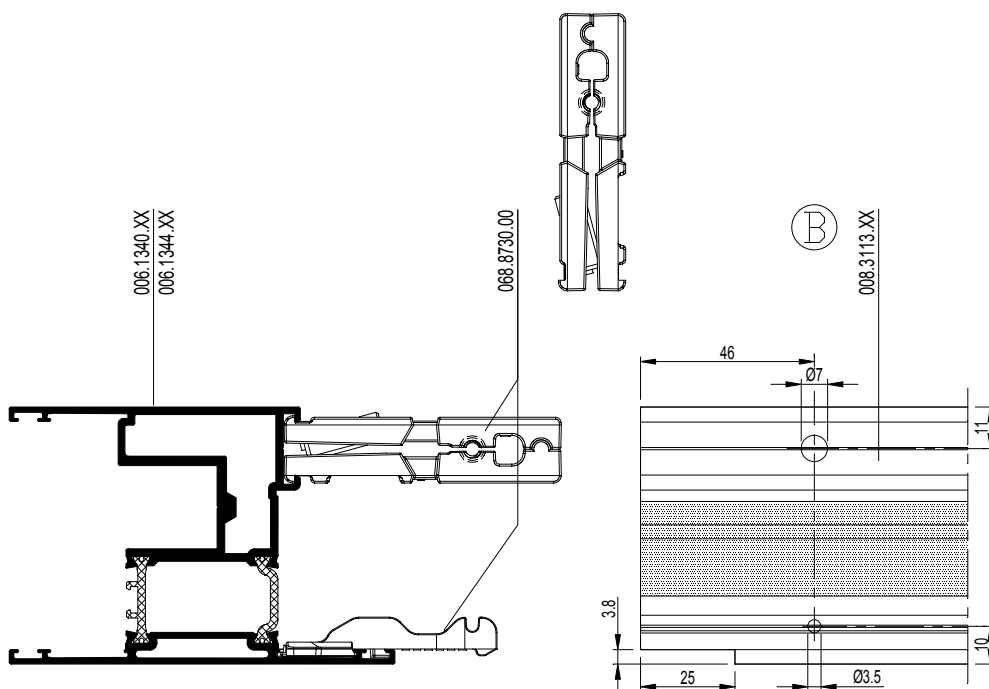
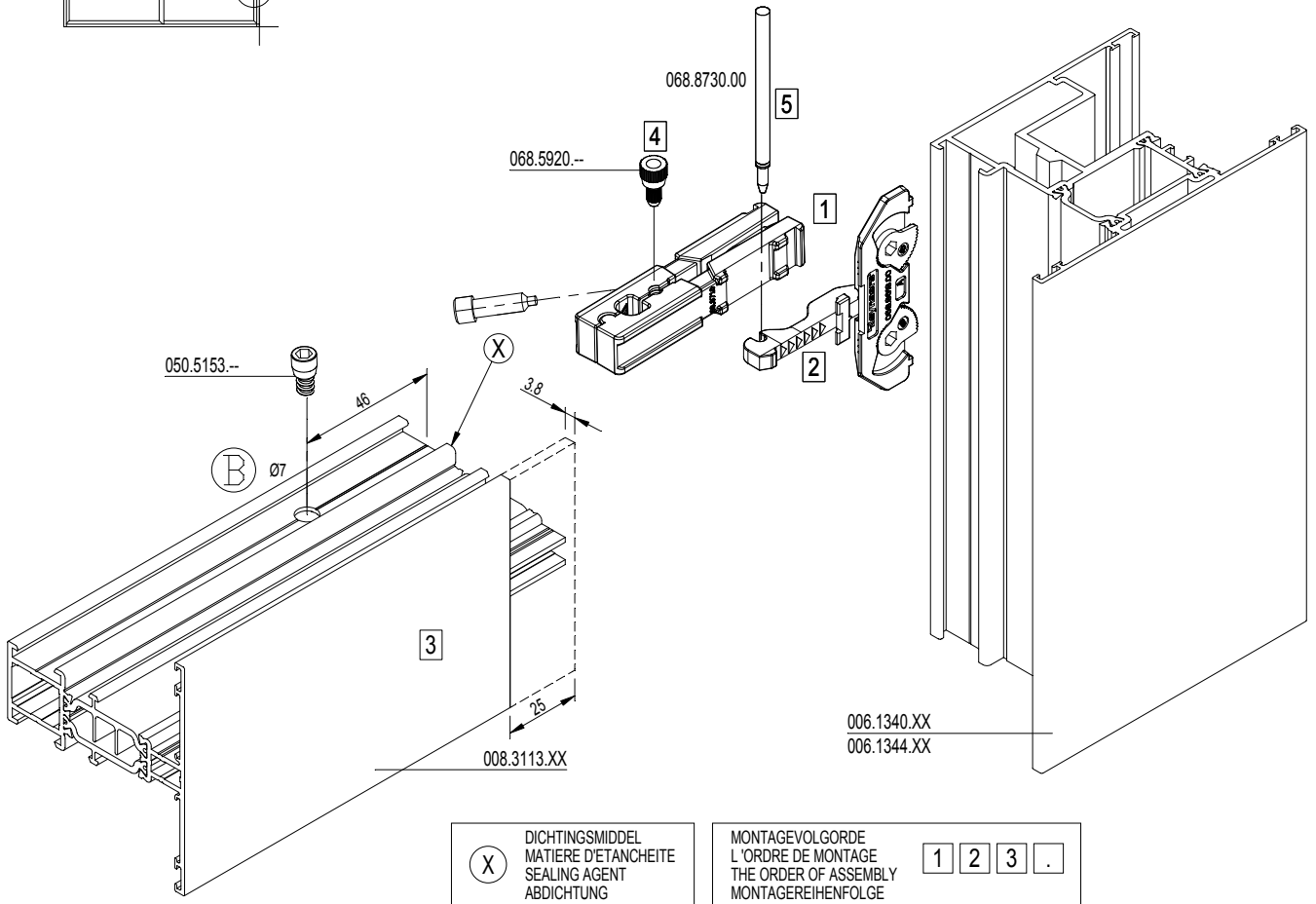
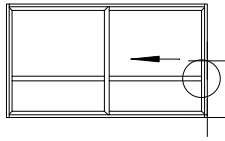

CP 155 CP 155-LS

T-VERBINDING MONORAIL
RACCORDEMENT-T MONORAIL
T-CONNECTION MONORAIL
T-VERBINDUNG MONORAIL

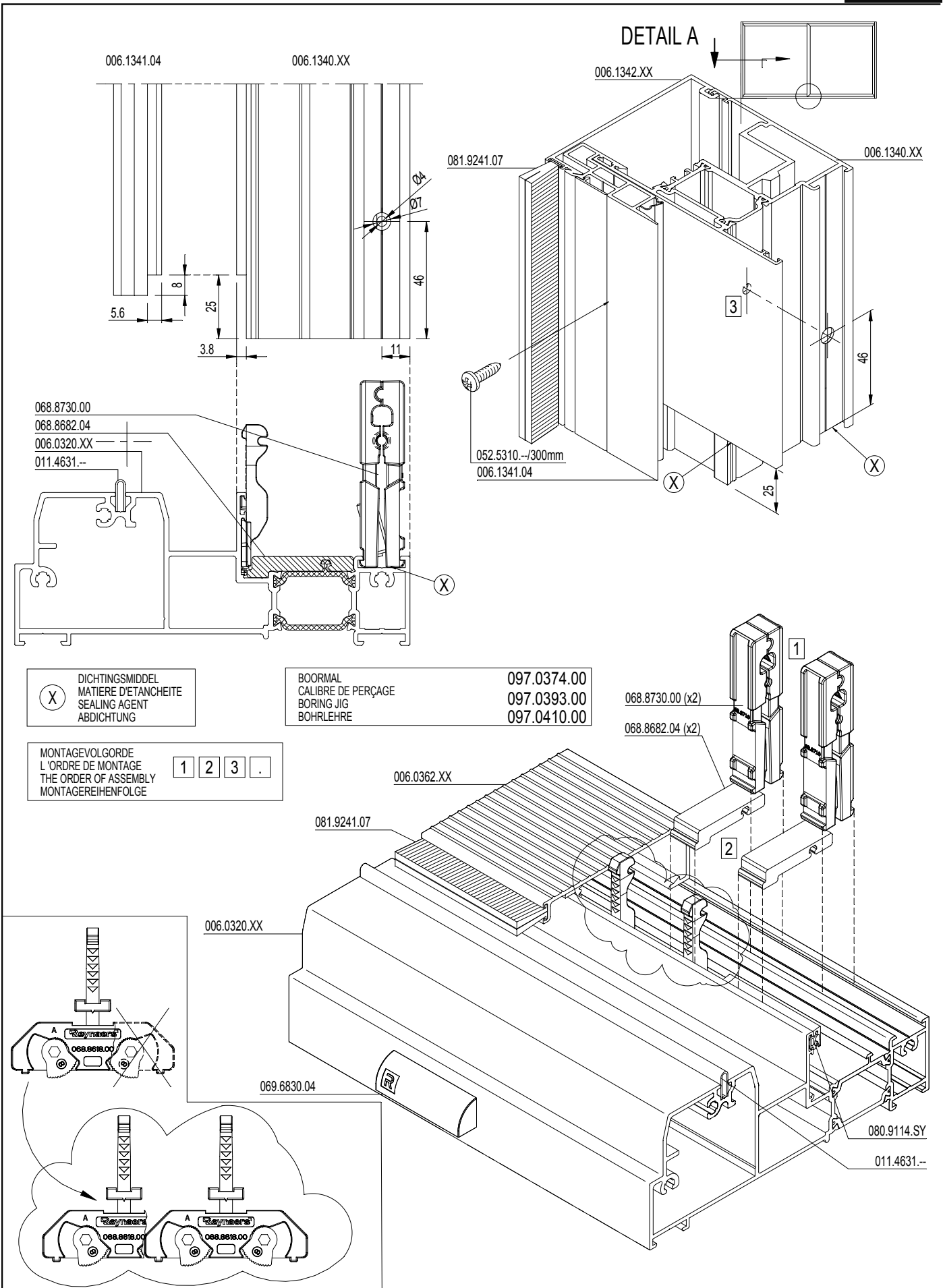

(X) DICHTINGSMIDDEL
MATIÈRE D'ÉTANCHEITÉ
SEALING AGENT
ABDICHTUNG

BOORMAL
CALIBRE DE PERÇAGE
BORING JIG
BOHRLEHRE

097.0374.00
097.0393.00
097.0410.00

MONTAGEVOLGORDE
L'ORDRE DE MONTAGE
THE ORDER OF ASSEMBLY
MONTAGEREIHENFOLGE

1 2 3 .

D0013960

DETAIL A

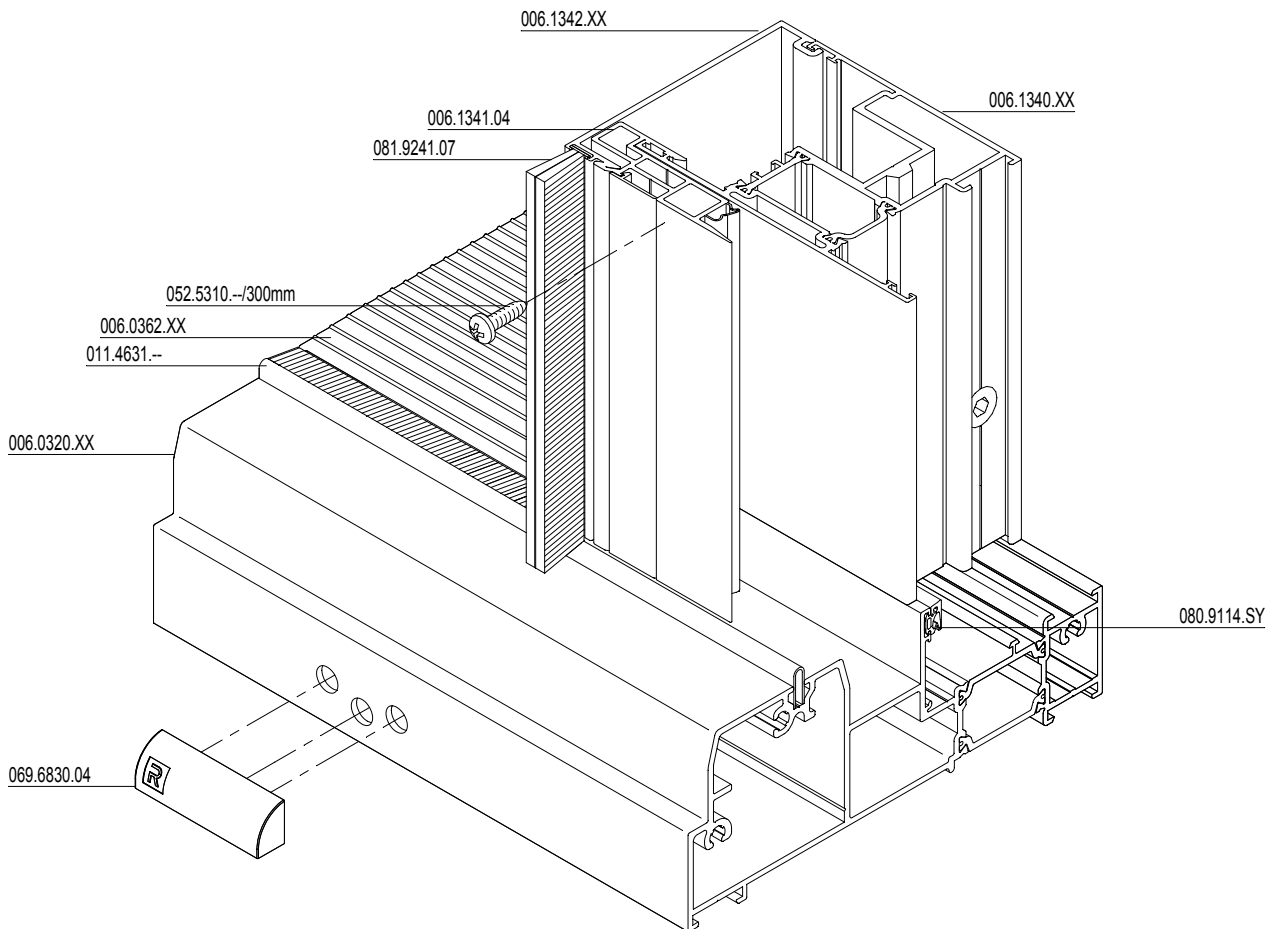
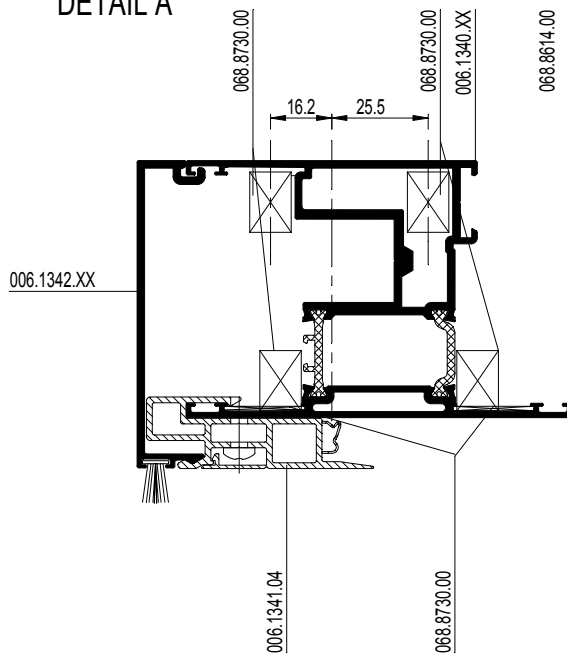

CP 155 CP 155-LS

T-VERBINDING MONORAIL
RACCORDÉMENT-T MONORAIL
T-CONNECTION MONORAIL
T-VERBINDUNG MONORAIL



CP 155 CP 155-LS

T-VERBINDING MONORAIL
RACCORDEMENT-T MONORAIL
T-CONNECTION MONORAIL
T-VERBINDUNG MONORAIL



BOORMAL	097.0374.00
CALIBRE DE PERÇAGE	097.0393.00
BORING JIG	097.0410.00
BOHRLEHRE	097.0410.00

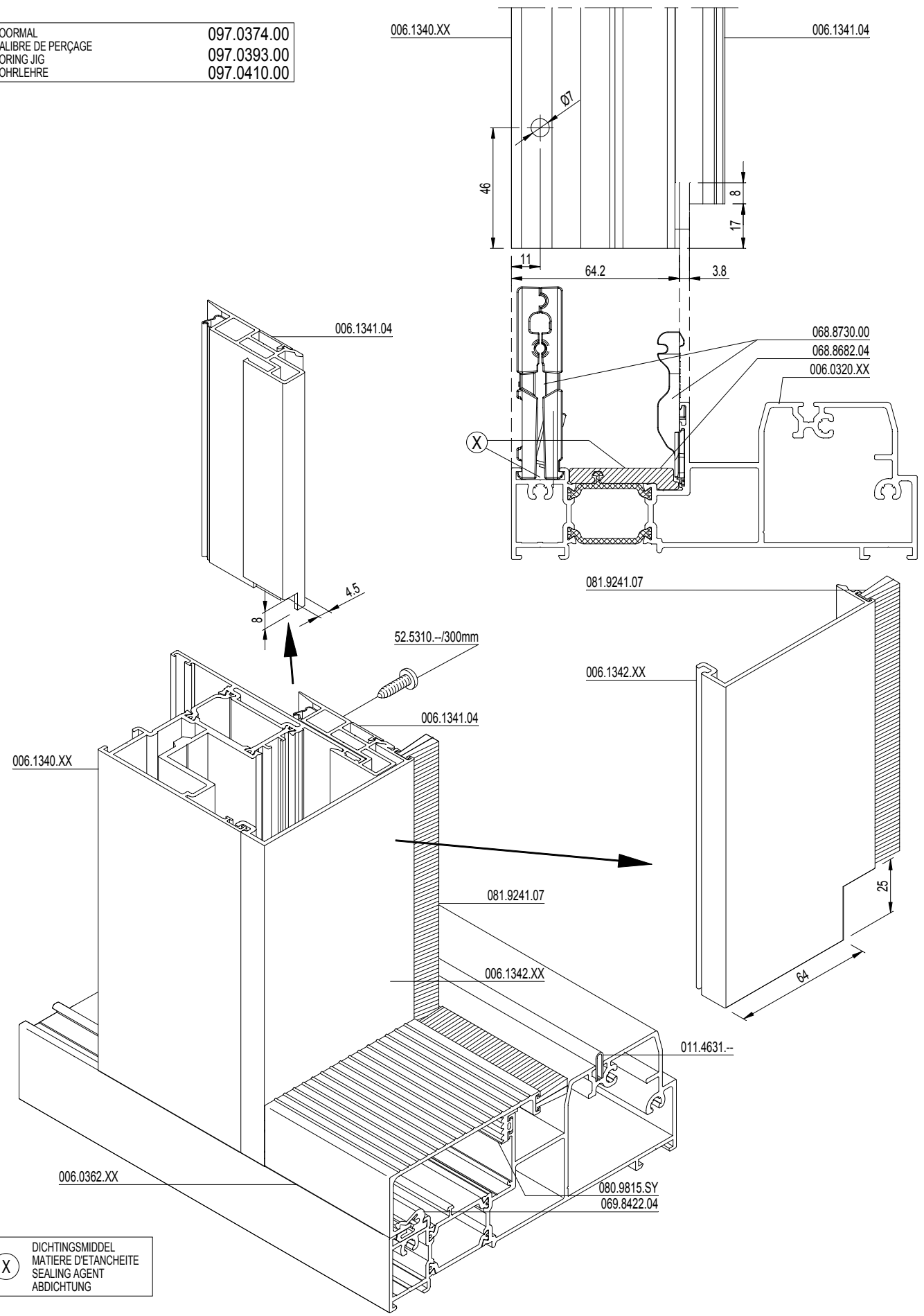

(X) DICHTINGSMIDDEL
MATIERE D'ETANCHEITE
SEALING AGENT
ABDICHTUNG

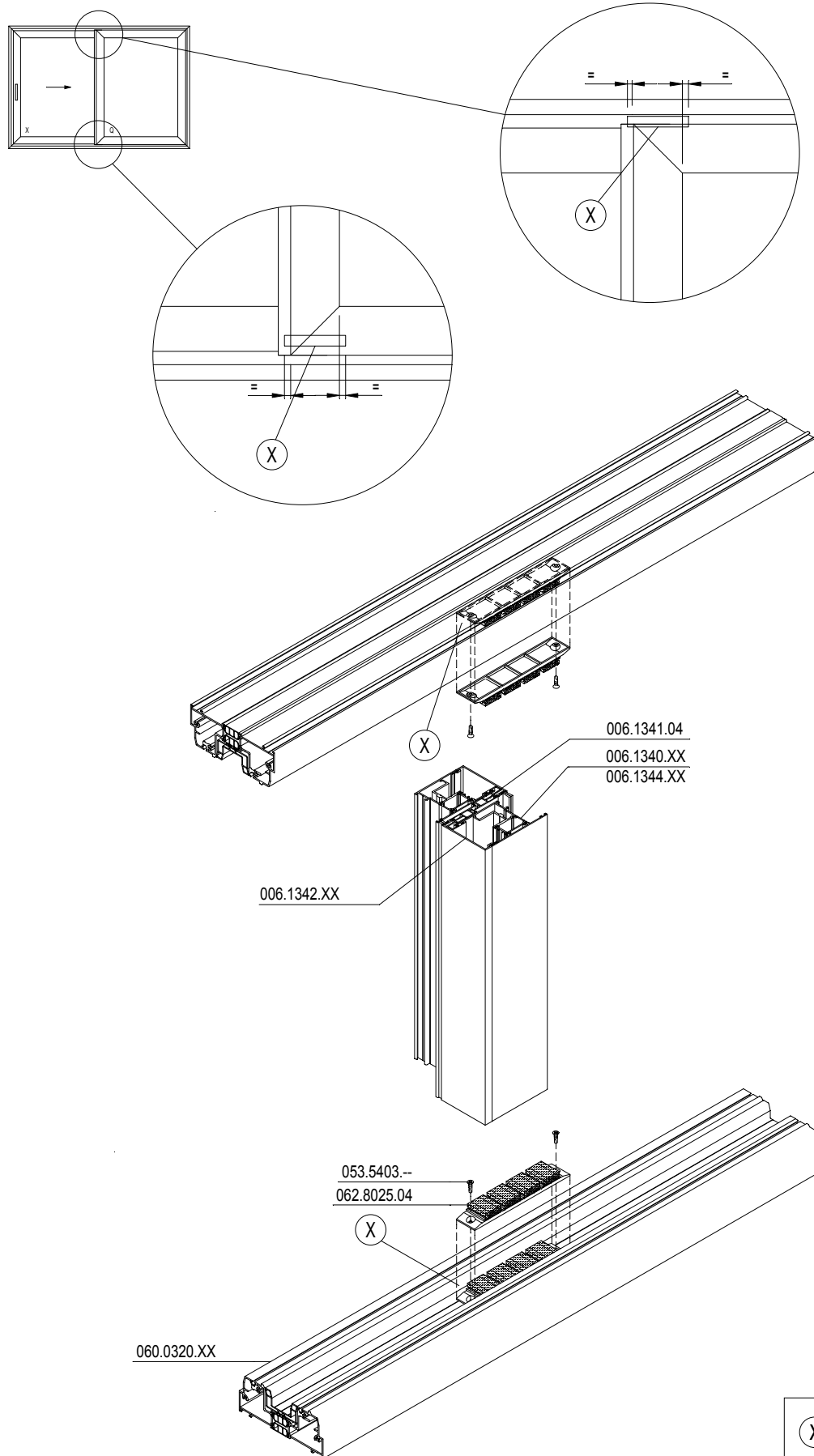

(X) DICHTINGSMIDDEL
 MATIERE D'ETANCHEITE
 SEALING AGENT
 ABDICHTUNG

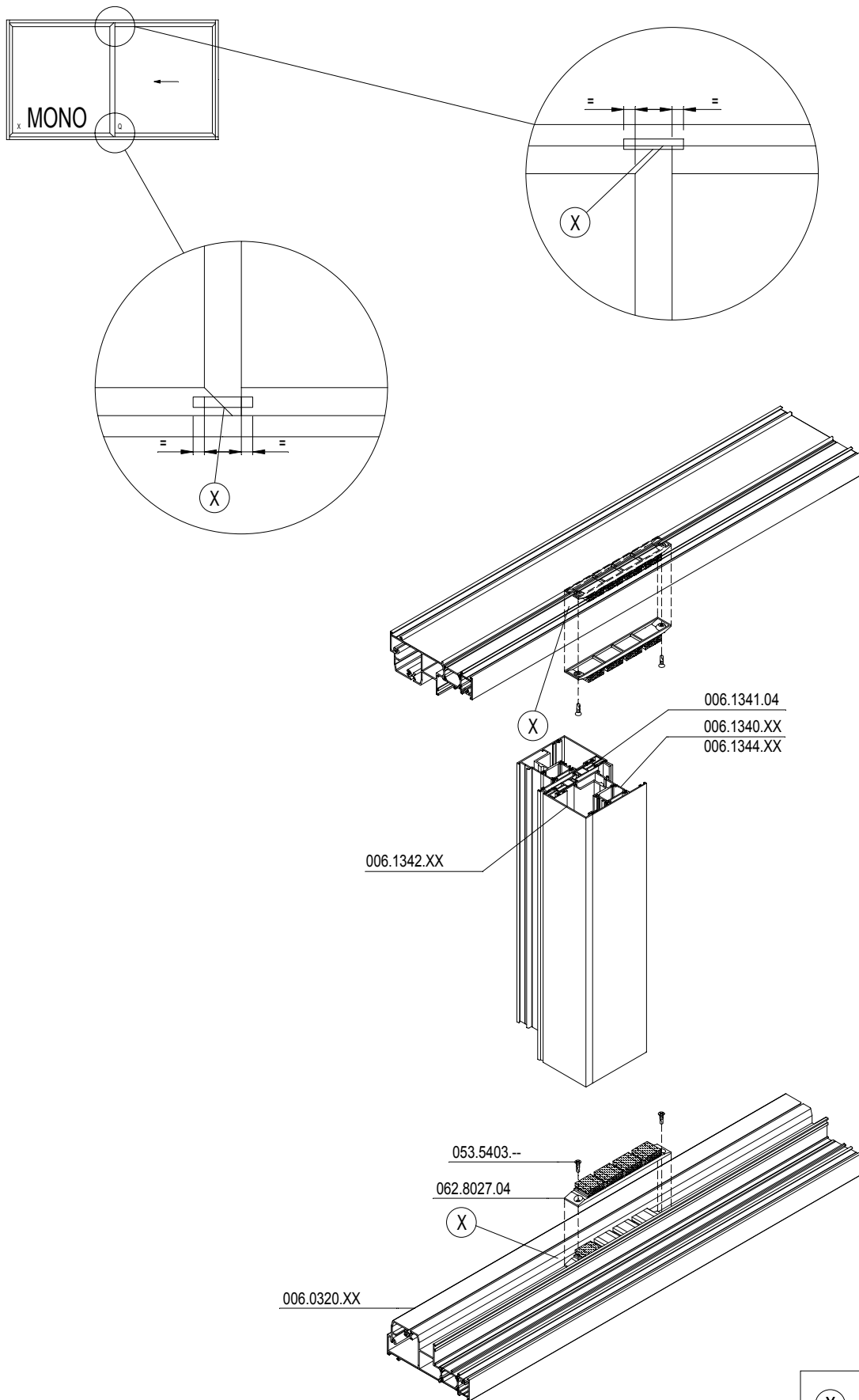

(X) DICHTINGSMIDDEL
 MATIERE D'ETANCHEITE
 SEALING AGENT
 ABDICHTUNG

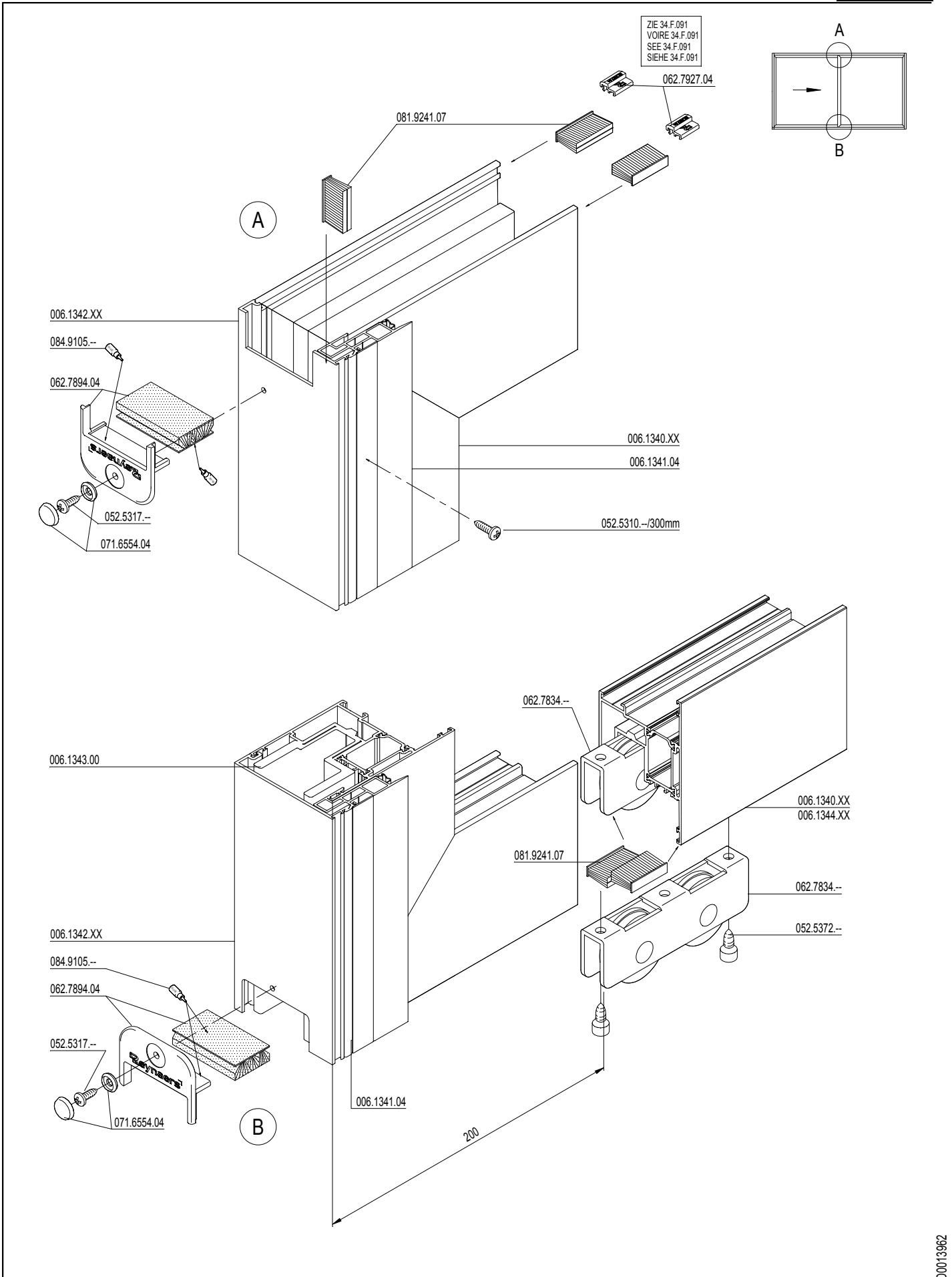

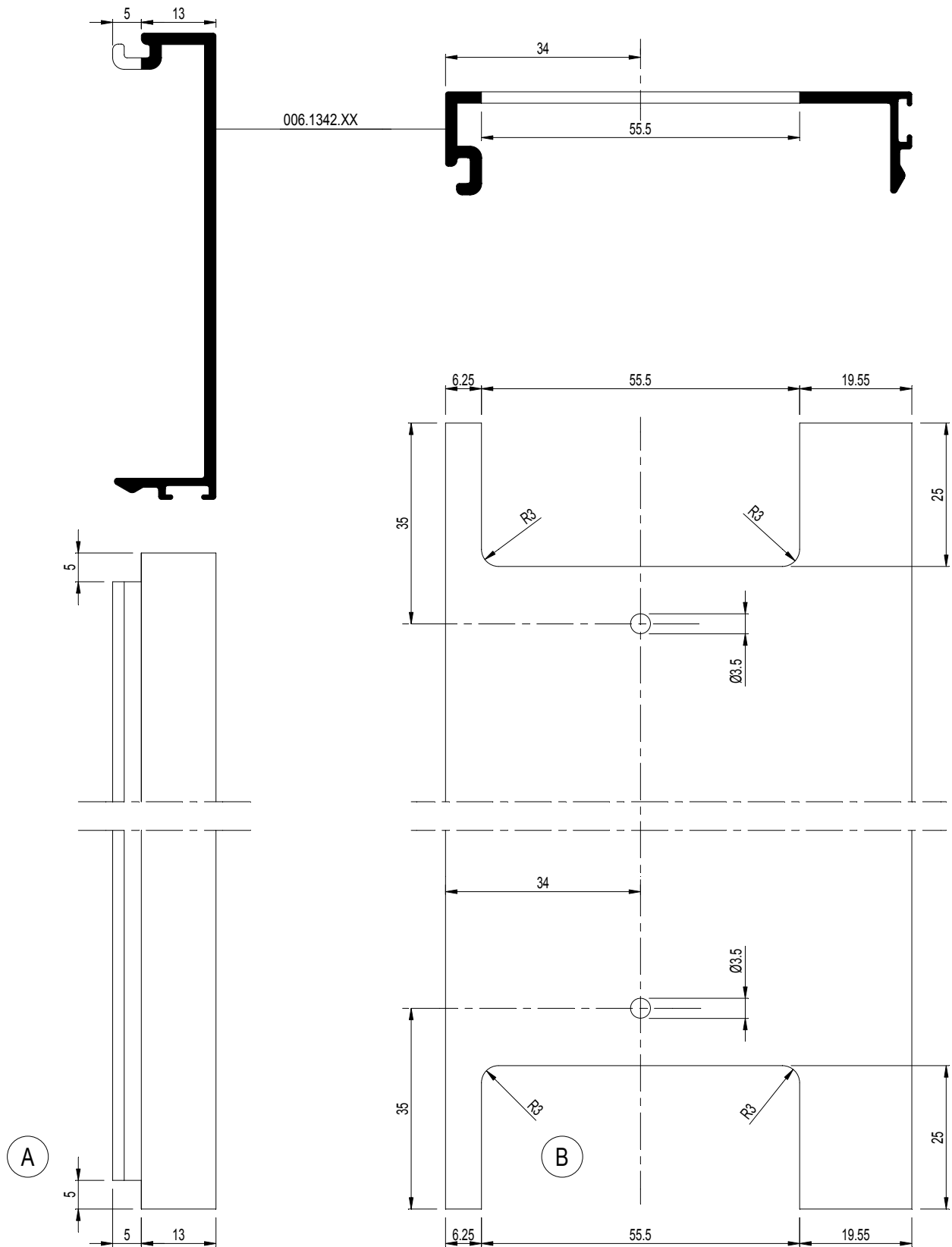

	097.U300.00	A
	+ 097.U400.00	B

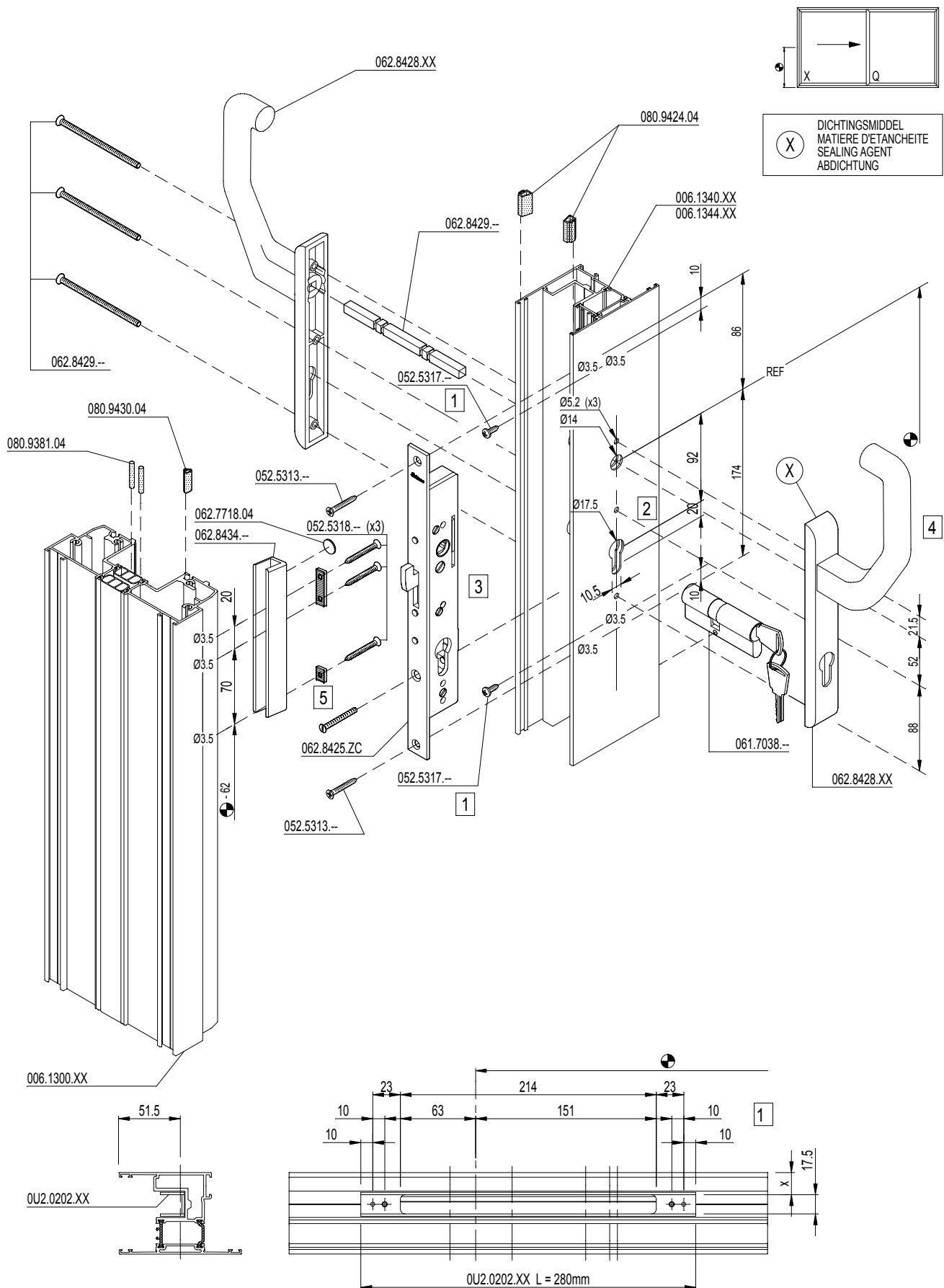

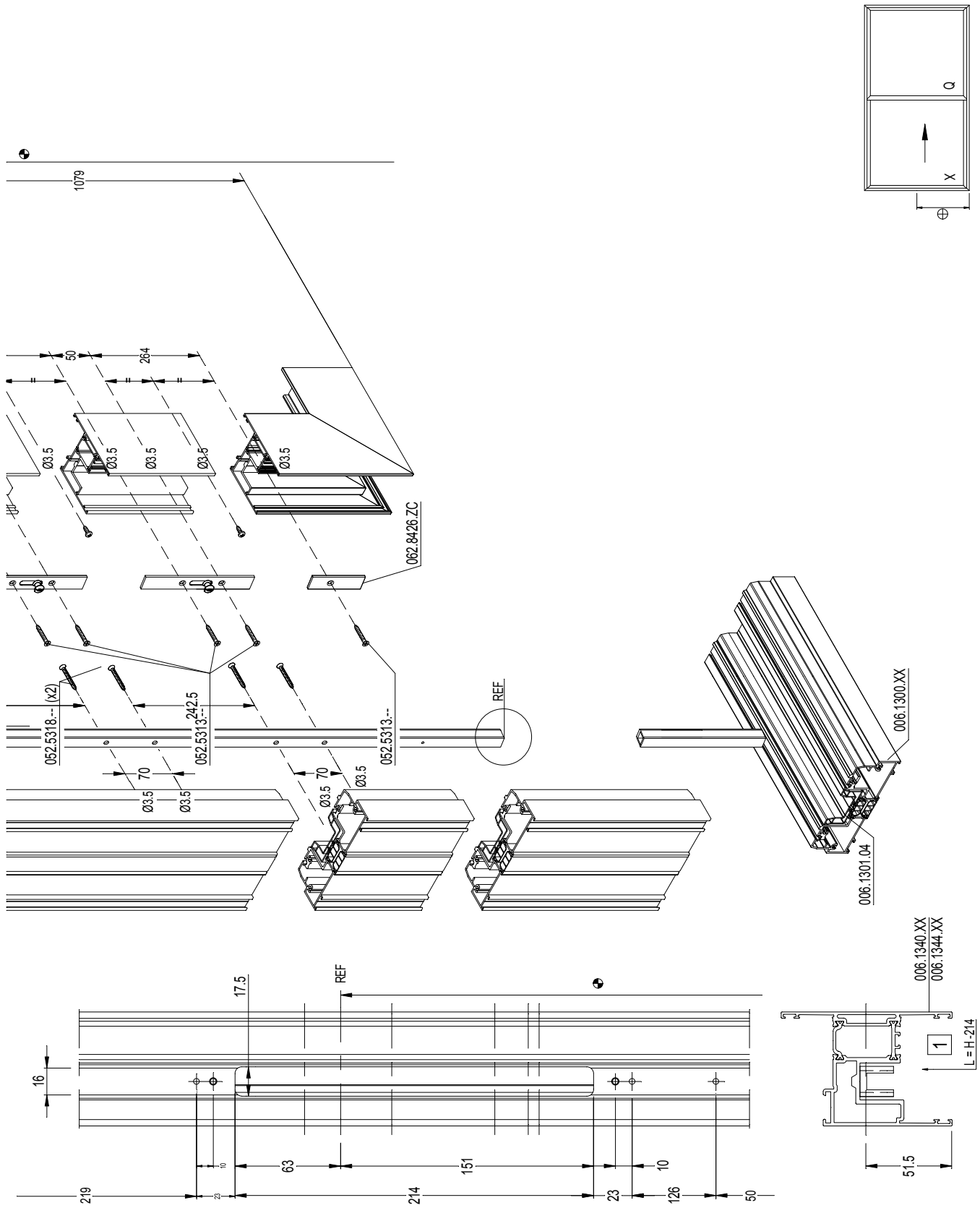

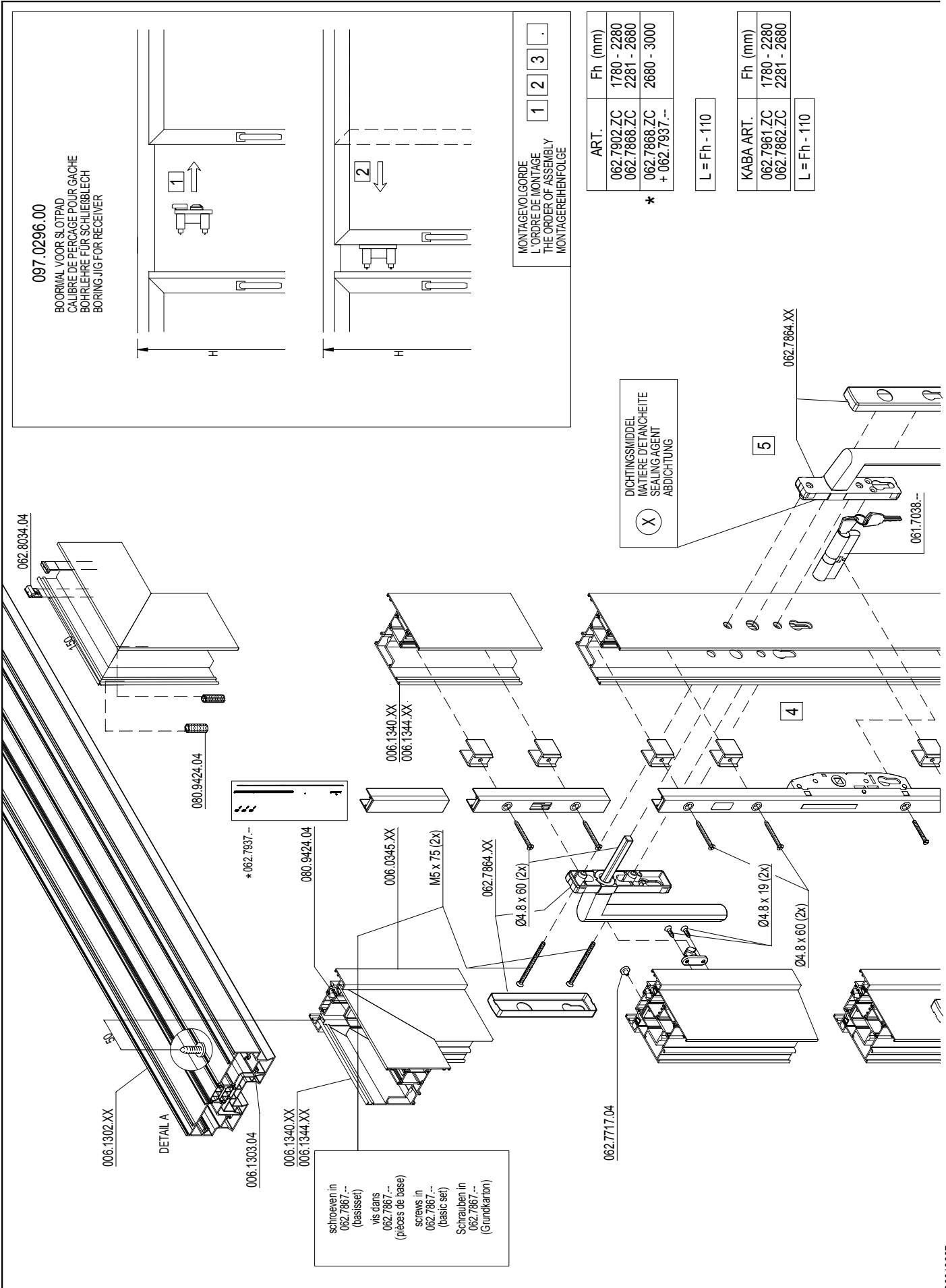

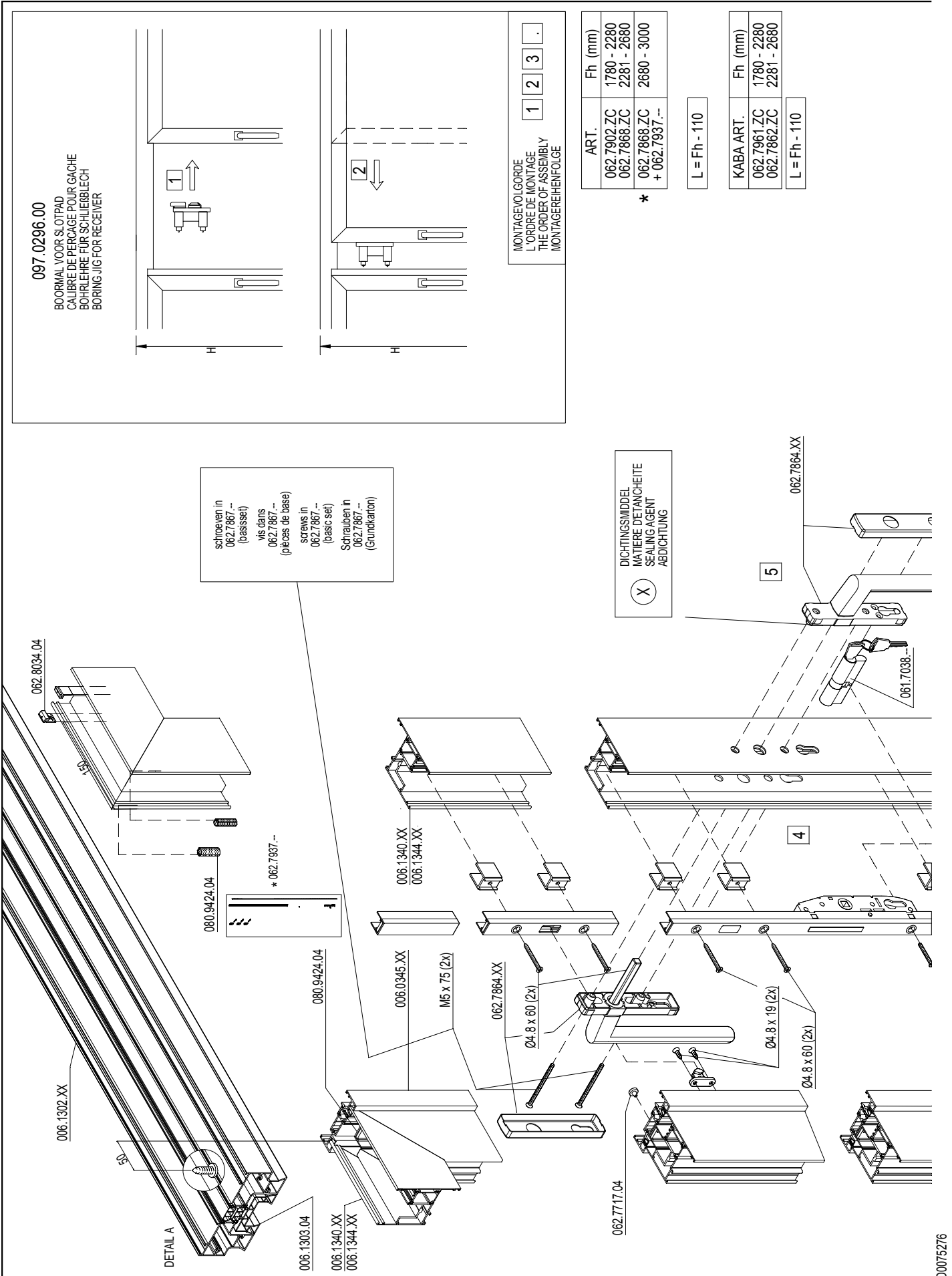

CP 155

INBOUW BASISSET HEFSCHUIFDEUR 4-RAIL MIN. 300KG MAX. 400KG
 ENCASTREMENT PIECES DE BASE SOULEV. COULISS. 4-RAIL MIN.
 EMBEDDING BASIC SET LIFT AND SLIDING DOOR 4-RAIL MIN. 300KG
 EINBAU GRUNDKARTON HEBESCHIEBETUER 4-RAIL MIN. 300KG MAX.

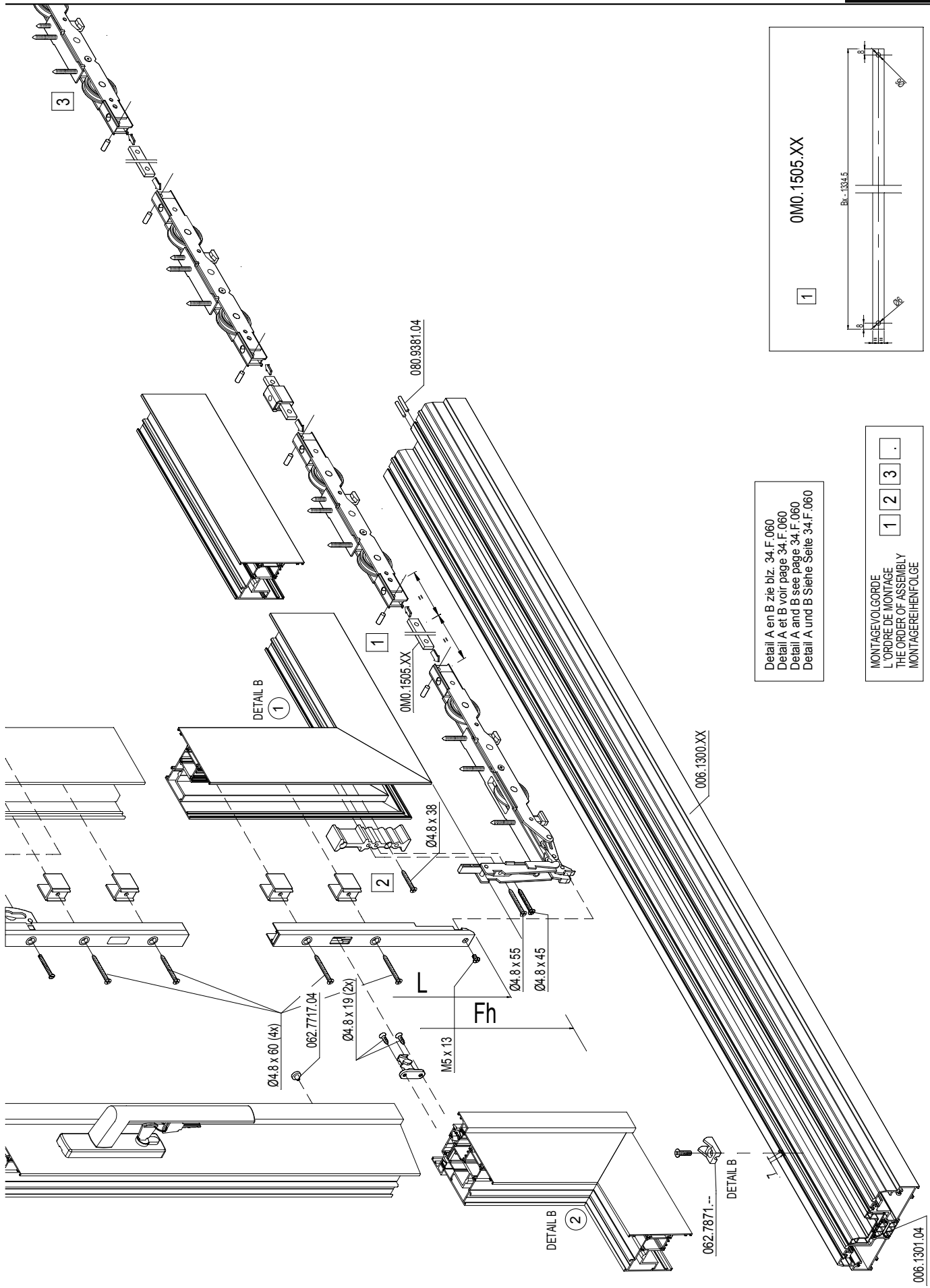

CP 155-LS

INBOUW BASISSET HEFSCHUIFDEUR 4-RAIL
ENCASTREMENT PIECES DE BASE SOULEV. COULISS. 4-RAIL
EMBEDDING BASIC SET LIFT AND SLIDING DOOR 4-RAIL
EINBAU GRUNDKARTON HEBESCHIEBETUER 4-RAIL



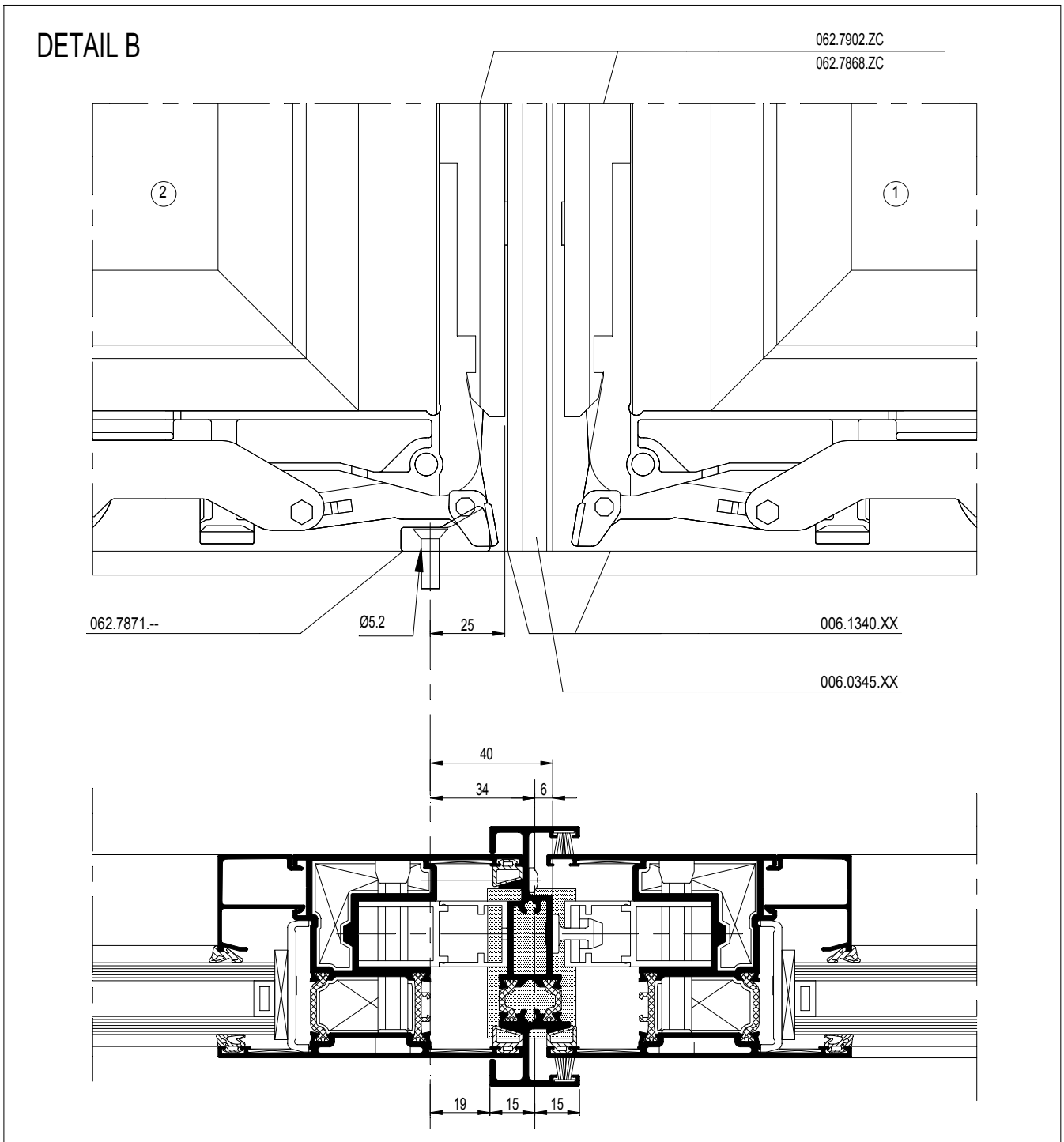
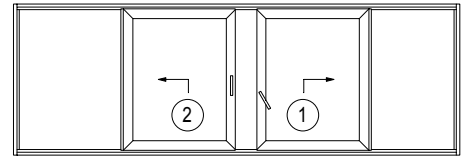
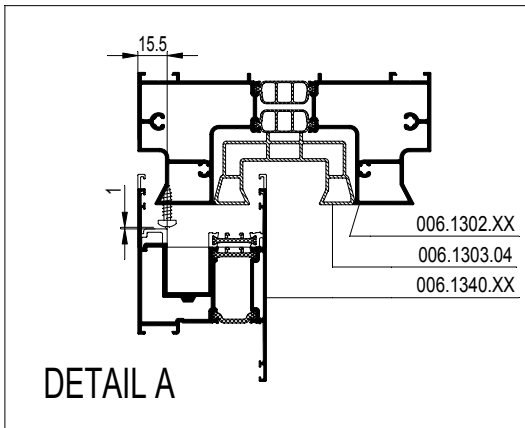

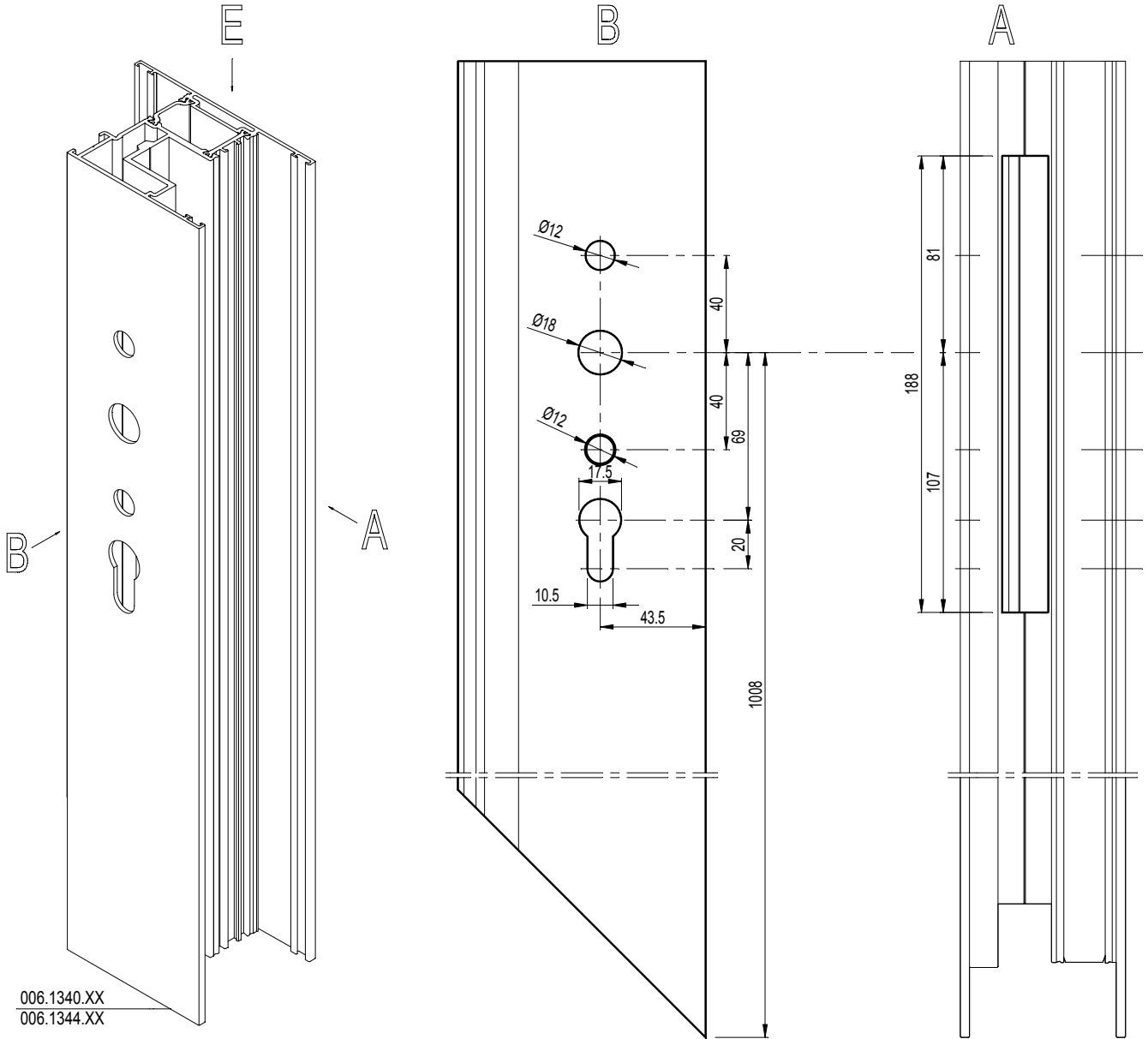

006.1340.XX
 006.1344.XX

	095.A700.00
	095.A730.00
	095.B300.00
	095.B323.00

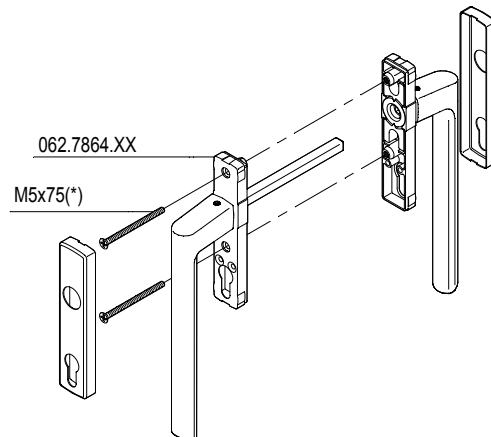

006.1340.XX
 006.1344.XX

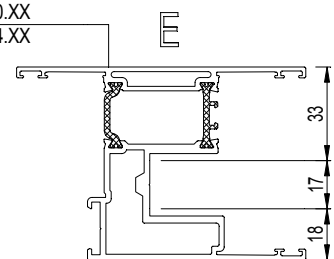

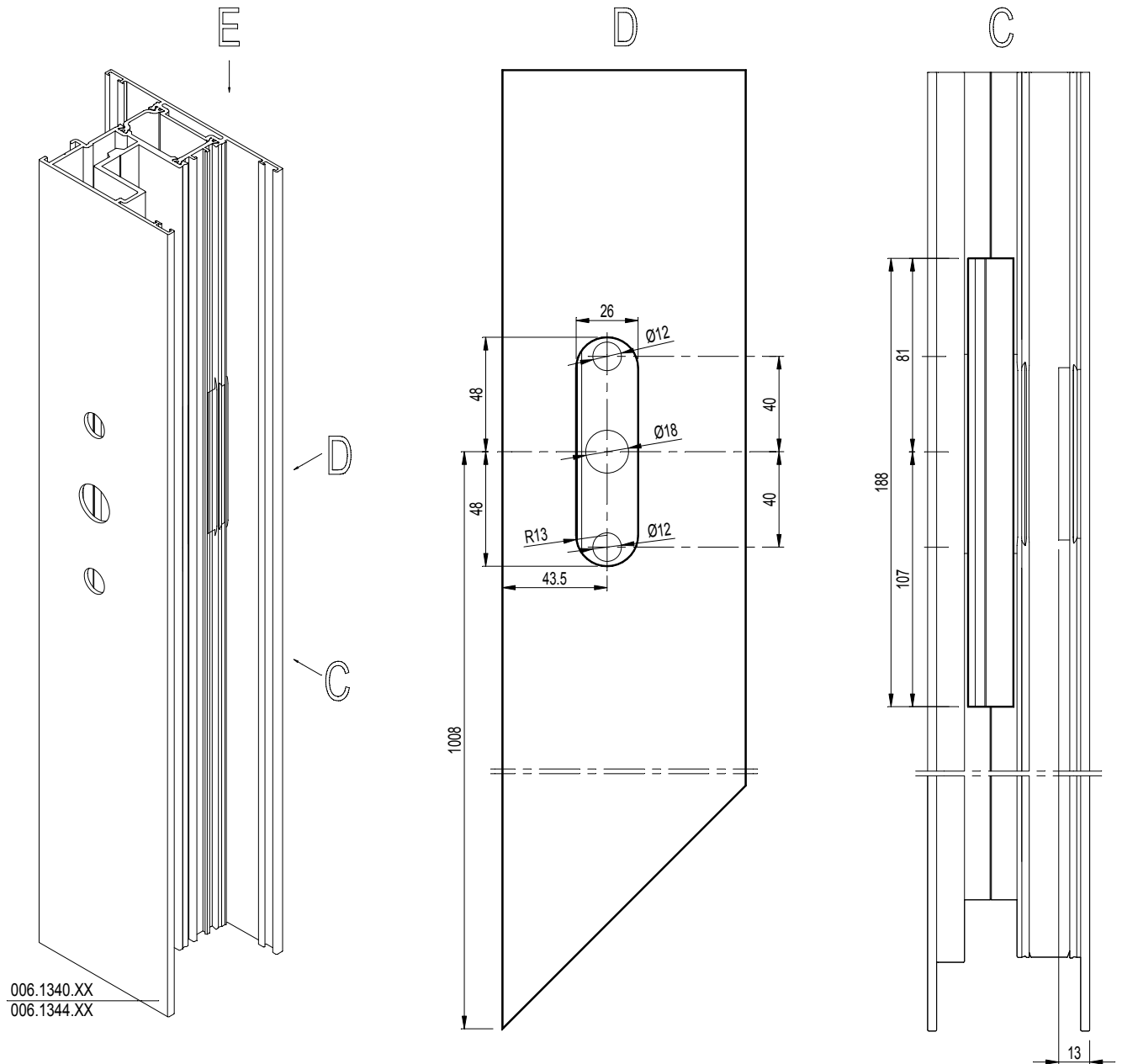

006.1340.XX
 006.1344.XX

	095.A700.00
	095.A730.00
	095.B300.00
	095.B323.00

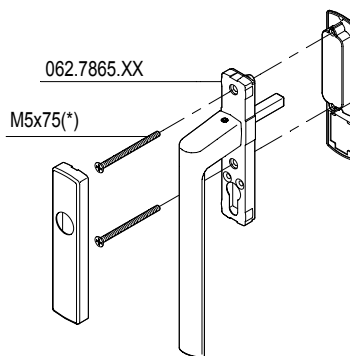

(*) SCHROEVEN M5x75 IN BASISSET
 VIS M5x75 DANS SET DE BASE
 SCREWS M5x75 IN BASIC SET
 SCHRAUBEN M5x75 IM GRUNDKARTON

062.7867.--

CP 155-LS

MONTAGE DEURKRUK KABA
ASSEMBLAGE BEQUILLE KABA
ASSEMBLY DOOR HANDLE KABA
MONTAGE TUERDRUECKER KABA



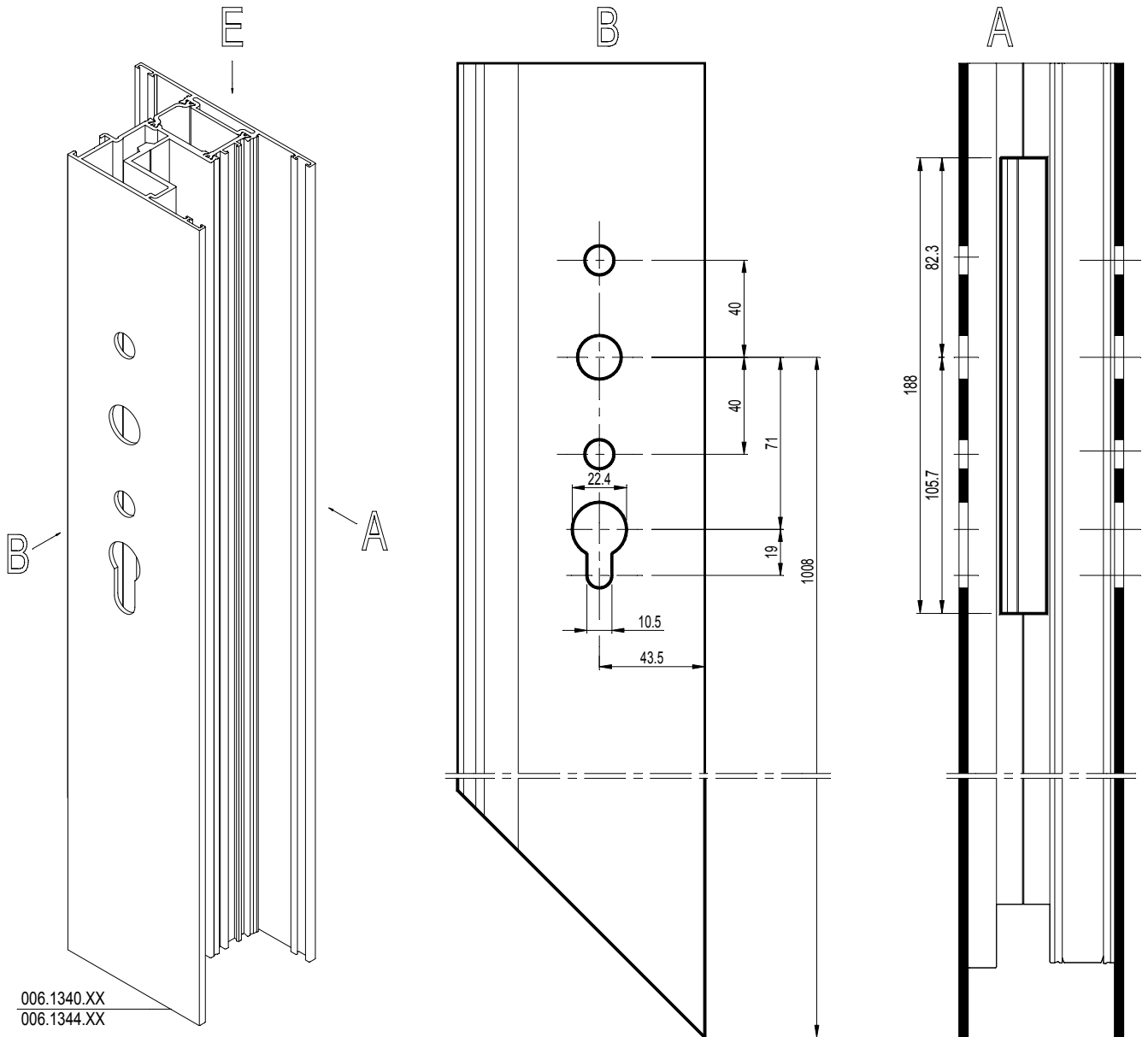

006.1340.XX
 006.1344.XX

	095.A700.00
	095.A730.00
	095.B300.00
	095.B323.00

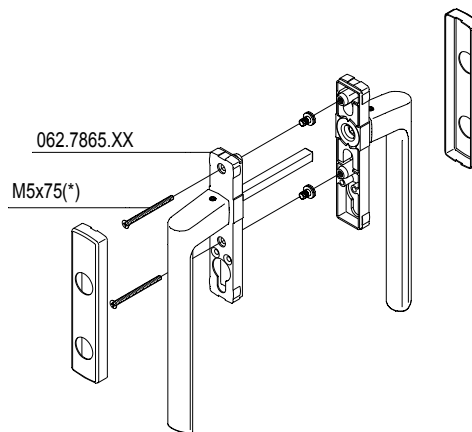

006.1340.XX
 006.1344.XX

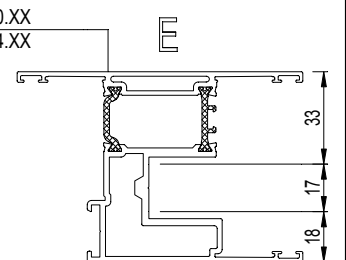

(*) SCHROEVEN M5x75 IN BASISSET
 VIS M5x75 DANS SET DE BASE
 SCREWS M5x75 IN BASIC SET
 SCHRAUBEN M5x75 IM GRUNDKARTON

062.7867.--

CP 155 CP 155-LS

INBRAAKWEREND
PROTECTION ANTI-VOL
BURGLAR PROTECTION
EINBRUCHHEMMEND

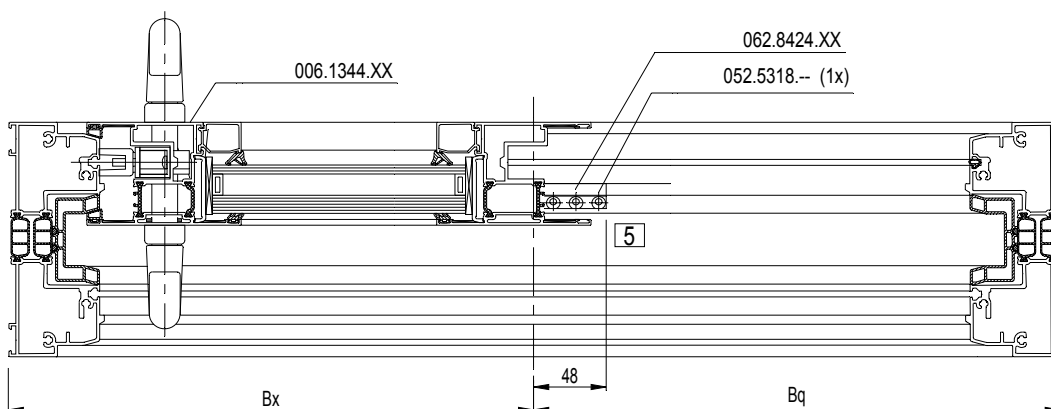
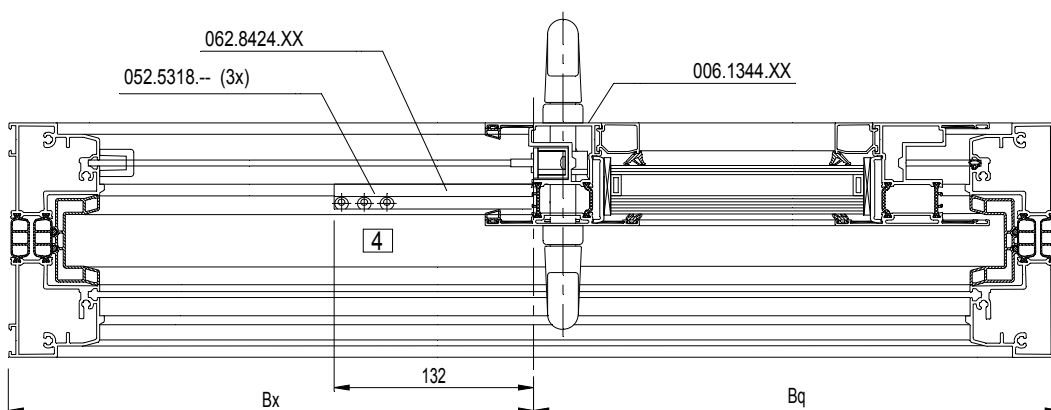
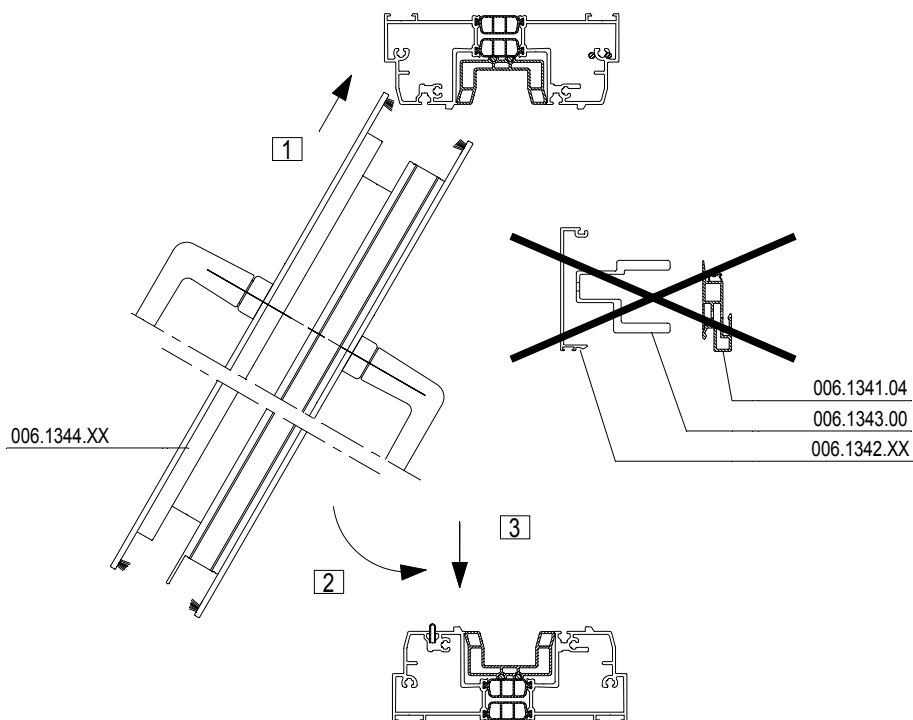

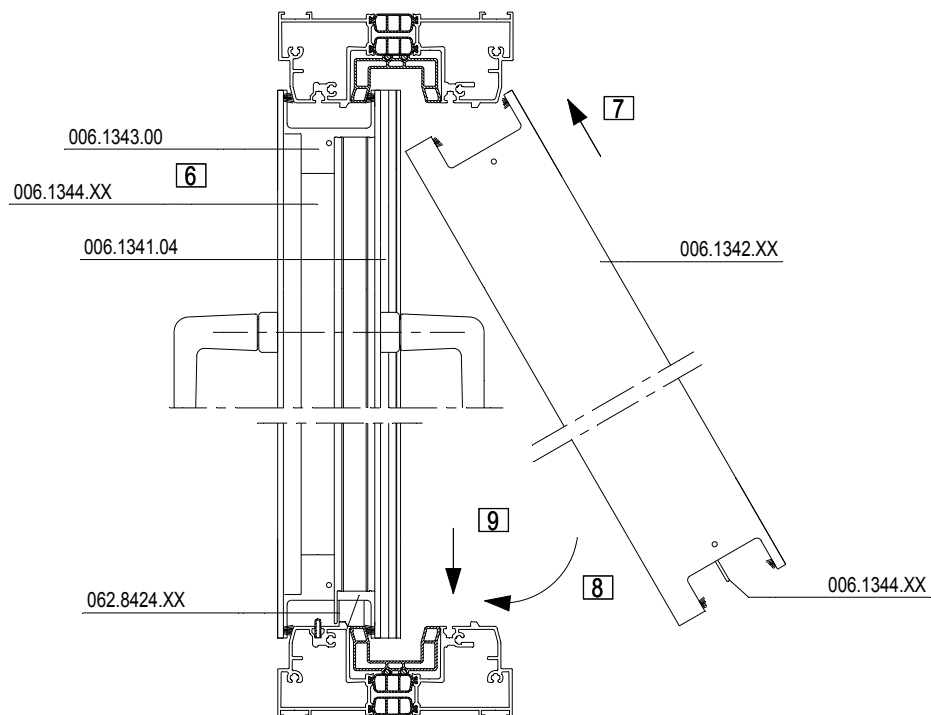

1-3: DE SCHUIVENDE VLEUGEL MONTEREN TUSSEN HET BUITENKADER OP DE BINNENRAIL.
DE SCHUIVENDE VLEUGEL IS NIET VOORZIEN VAN DE HULPPROFIELEN: 006.1341.04,
006.1342.XX EN 006.1343.00.

4: DE SCHUIVENDE VLEUGEL NAAR RECHTS SCHUIVEN.
DE INBRAAKBEVEILIGING 062.8424.XX BEVESTIGEN OP HET BUITENKADER
MET DE SCHROEF 052.5318.-- (3x).

5: DE SCHUIVENDE VLEUGEL NAAR LINKS SCHUIVEN EN DE INBRAAKBEVEILIGING
062.8424.XX VERDER BEVESTIGEN MET DE SCHROEF 052.5318.-- (1x).

6: DE SCHUIVENDE VLEUGEL VOORZIEN VAN DE HULPPROFIELEN 006.1341.04,
006.1342.XX EN 006.1343.00.

7-9: DE VASTE VLEUGEL TUSSEN HET BUITENKADER MONTEREN.

1-3: MONTER L'OUVRANT COULISSANT ENTRE LE DORMANT SUR LE RAIL INTERIEUR.
L'OUVRANT COULISSANT N'EST PAS MUNI DES PROFILES DE SUPPORT: 006.1341.04,
006.1342.XX ET 006.1343.00.

4: POUSSER L'OUVRANT COULISSANT VERS LA DROITE.
FIXER LA PROTECTION ANTIVOL 062.8424.XX SUR LE DORMANT AU MOYEN
DE LA VIS 052.5318.-- (3x).

5: POUSSER L'OUVRANT COULISSANT VERS LA GAUCHE ET CONTINUER A FIXER
LA PROTECTION ANTIVOL 062.8424.XX AU MOYEN DE LA VIS 052.5318.-- (1x).

6: MUNIR L'OUVRANT COULISSANT DES PROFILES DE SUPPORT 006.1341.04,
006.1342.XX ET 006.1343.00.

7-9: MONTER L'OUVRANT FIXE ENTRE LE DORMANT.

1-3: FIT THE SLIDING PANEL BETWEEN THE OUTER FRAME ON THE INSIDE RAIL.
THE SLIDING PANEL IS NOT EQUIPPED WITH THE SUPPORTING PROFILES: 006.1341.04,
006.1342.XX AND 006.1343.00.

4: PUSH THE SLIDING PANEL TO THE RIGHT.
FIX THE BURGLAR PROTECTION 062.8424.XX ON THE OUTER FRAME
BY MEANS OF SCREW 052.5318.-- (3x).

5: PUSH THE SLIDING PANEL TO THE LEFT AND CONTINUE TO FIX
THE BURGLAR PROTECTION 062.8424.XX BY MEANS OF SCREW 052.5318.-- (1x).

6: EQUIP THE SLIDING PANEL WITH THE SUPPORTING PROFILES 006.1341.04,
006.1342.XX AND 006.1343.00.

7-9: FIT THE FIXED PANEL BETWEEN THE OUTER FRAME.

1-3: DEN SCHIEBEFLÜGEL ZWISCHEN DEN BLENDRAHMEN AUF DIE INNENSCHIENE MONTIEREN.
L'OUVRANT COULISSANT N'EST PAS MUNI DES PROFILES DE SUPPORT: 006.1341.04,
006.1342.XX UND 006.1343.00 AUSGESTATTET.

4: DEN SCHIEBEFLÜGEL NACH RECHTS SCHIEBEN.
DIE EINBRUCHSSICHERUNG 062.8424.XX AM BLENDRAHMEN BEFESTIGEN
MIT DER SCHRAUBE 052.5318.-- (3x).

5: DEN SCHIEBEFLÜGEL NACH LINKS SCHIEBEN UND
DIE EINBRUCHSSICHERUNG 062.8424.XX WEITER
MIT DER SCHRAUBE 052.5318.-- (1x) BEFESTIGEN.

6: DE? SCHIEBEFLÜGEL MIT DEN ZUSATZPROFILEN 006.1341.04,
006.1342.XX UND 006.1343.00 AUSSTATTEN.

7-9: DEN FESTEN FLÜGEL ZWISCHEN DEN BLENDRAHMEN MONTIEREN.

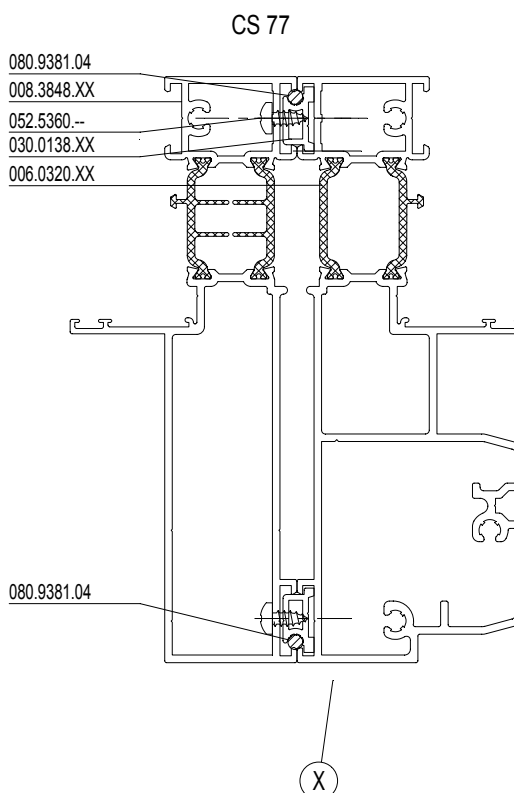
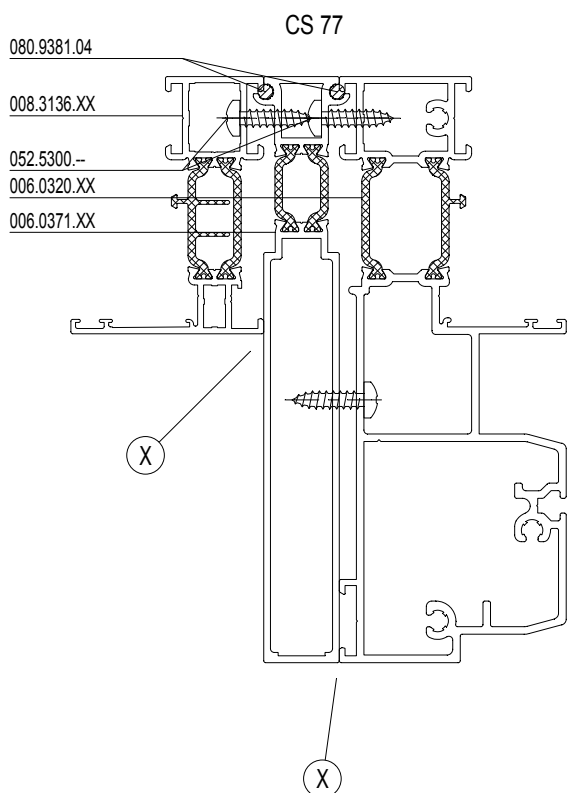
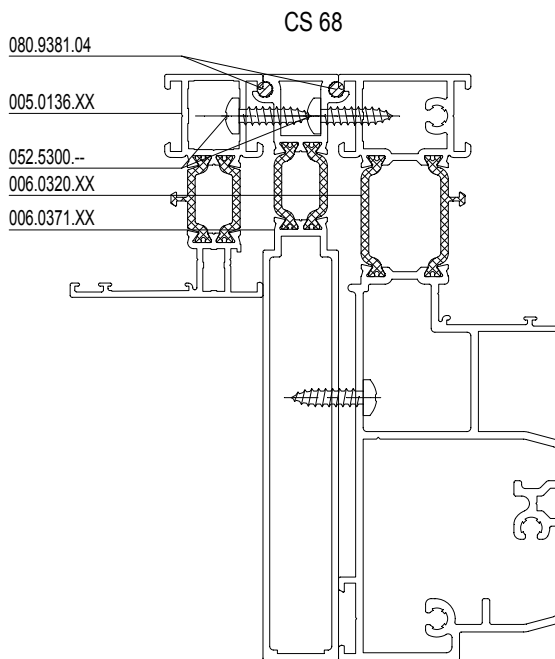
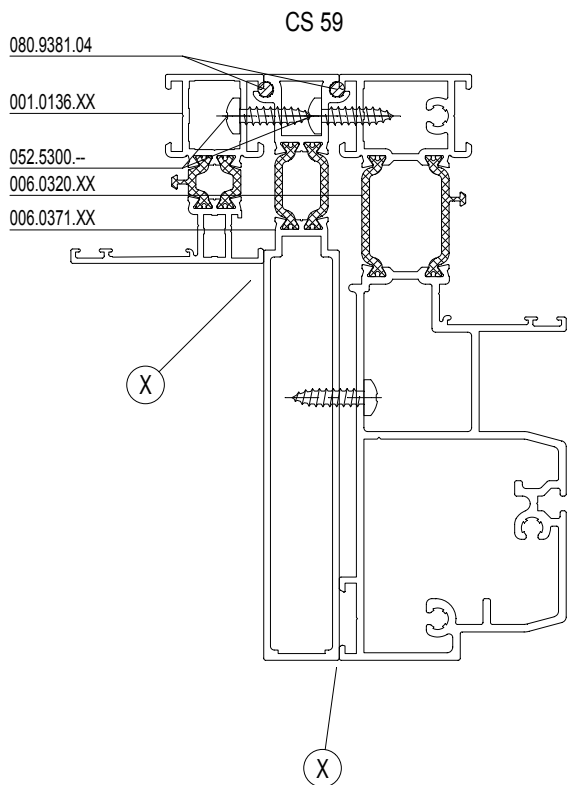

(X) DICHTINGSMIDDEL
MATIÈRE D'ÉTANCHEITE
SEALING AGENT
ABDICHTUNG

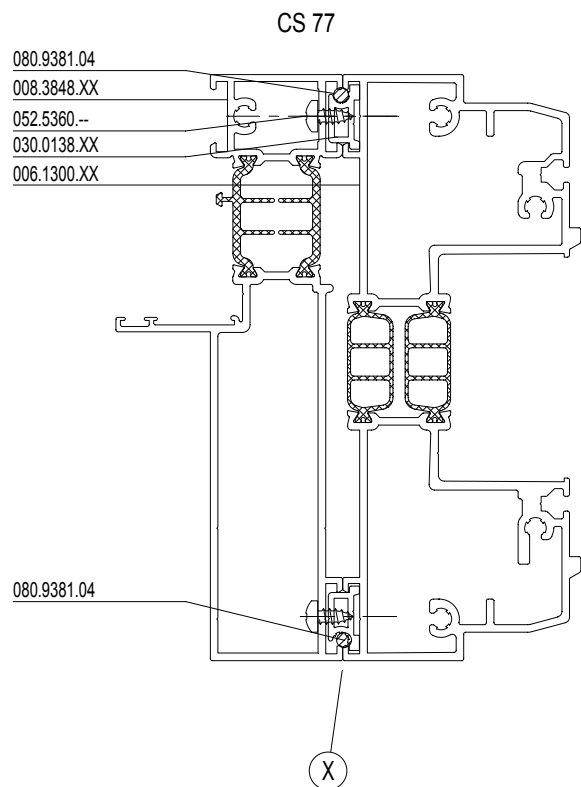
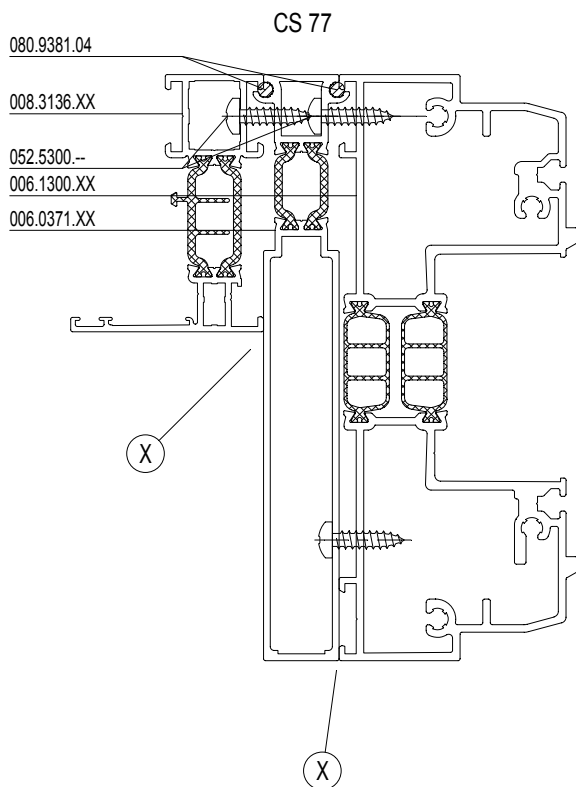
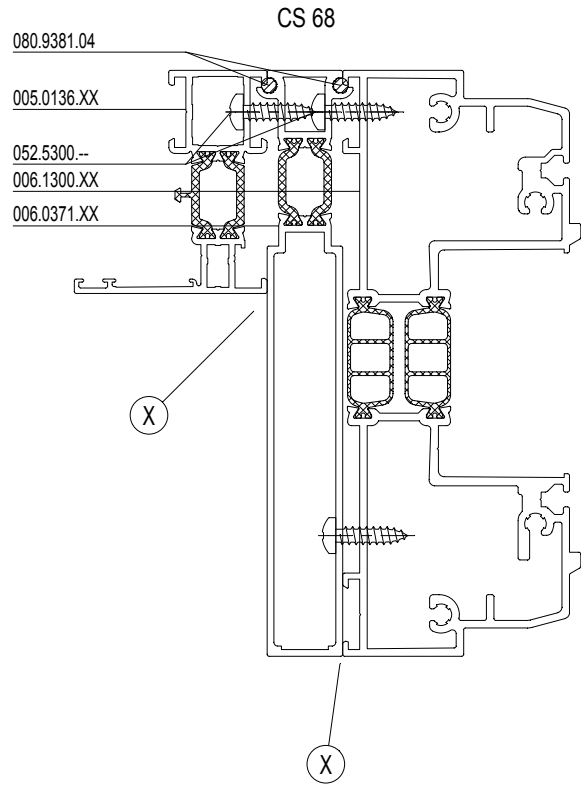
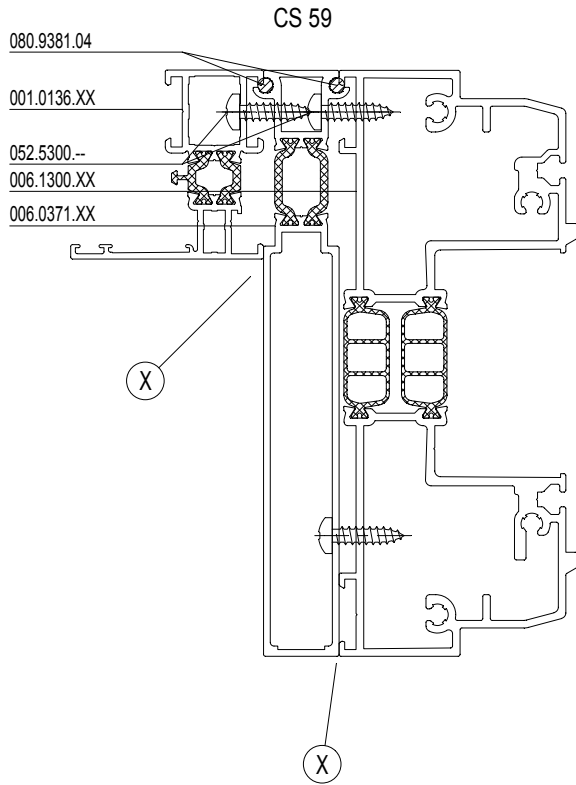

2-RAIL QXXQ

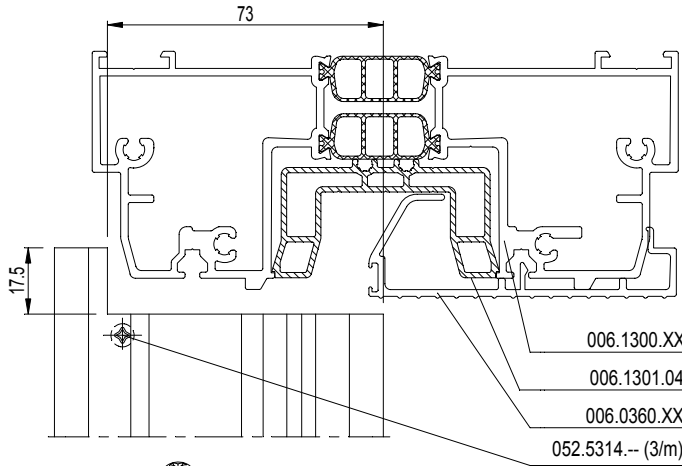
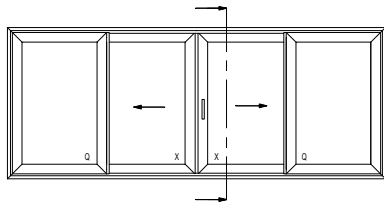

2-RAIL OXXO

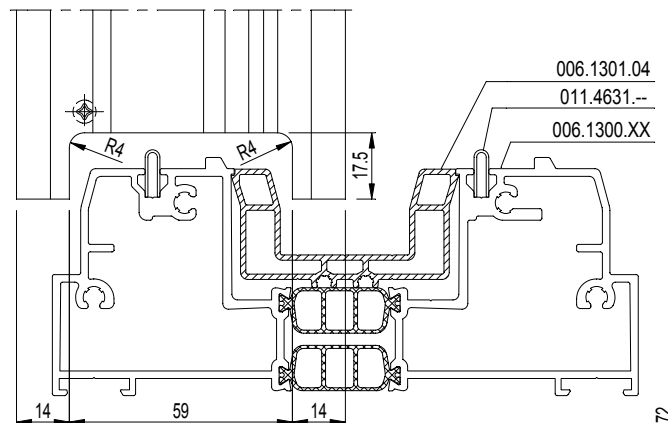
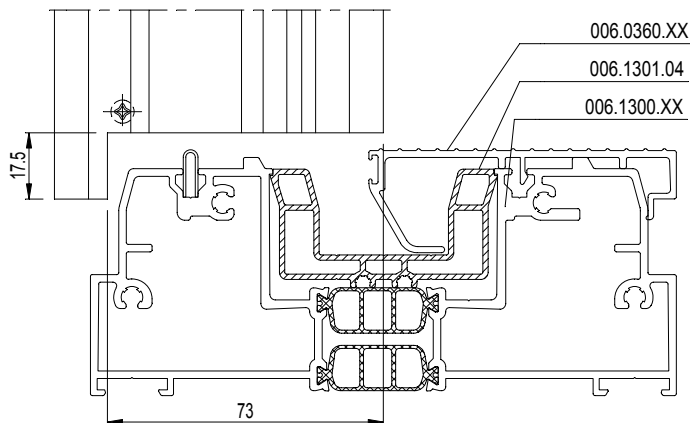
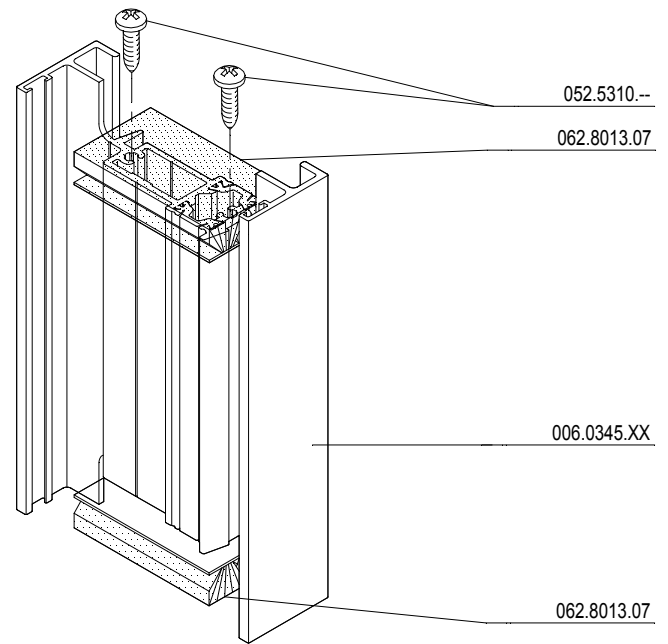
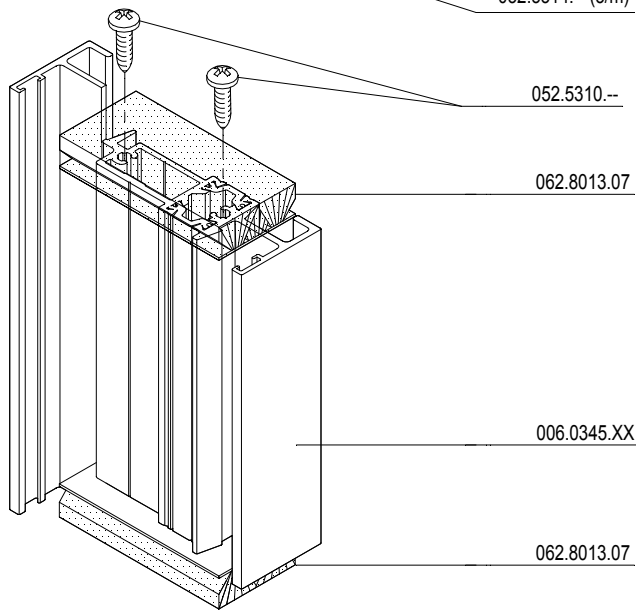
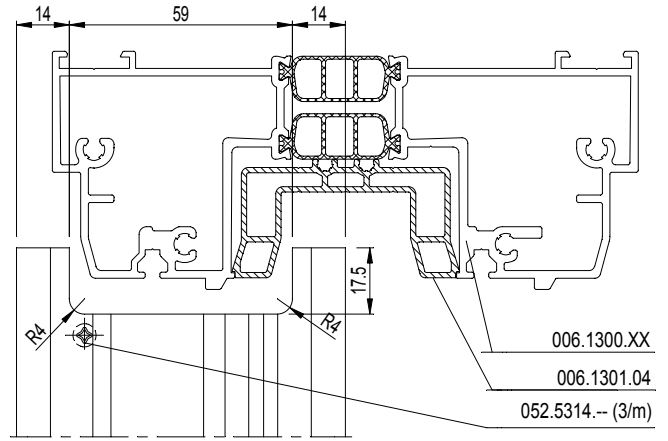
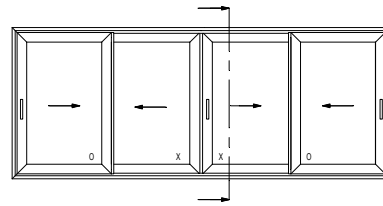

MONORAIL QXXQ

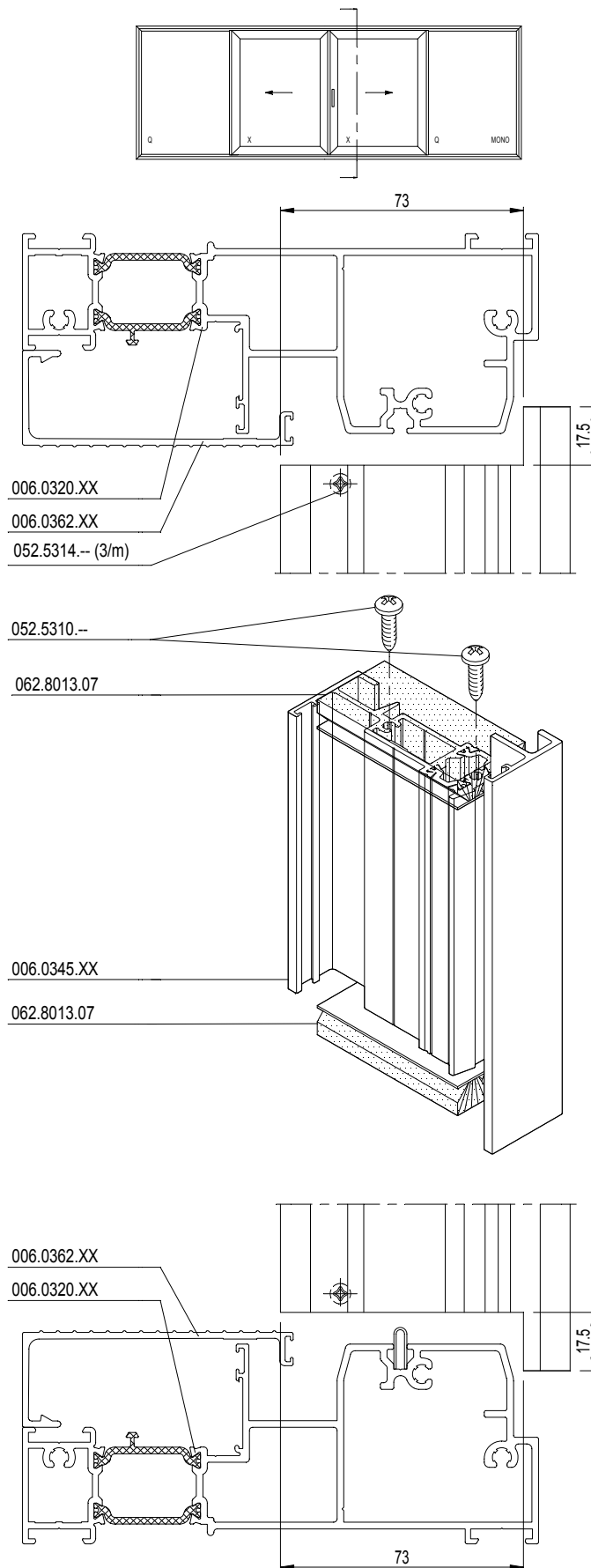

2-RAIL QXXQ

2-RAIL XXXX

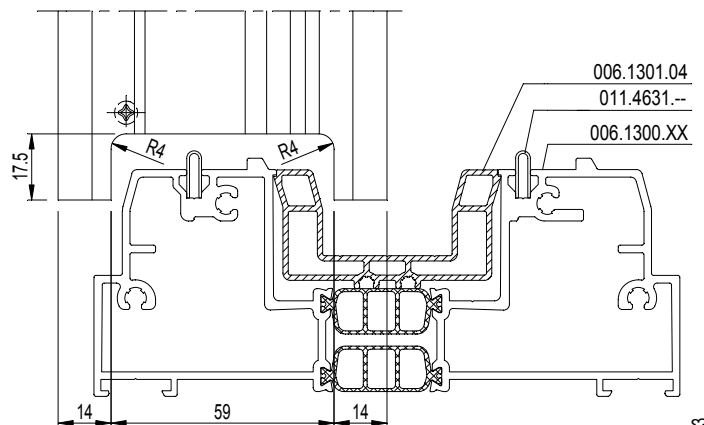
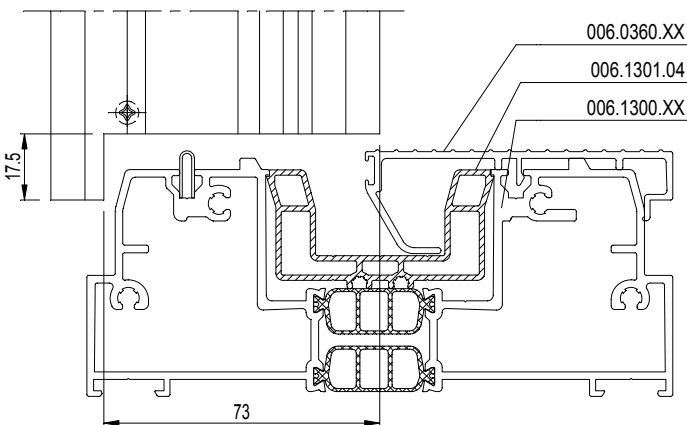
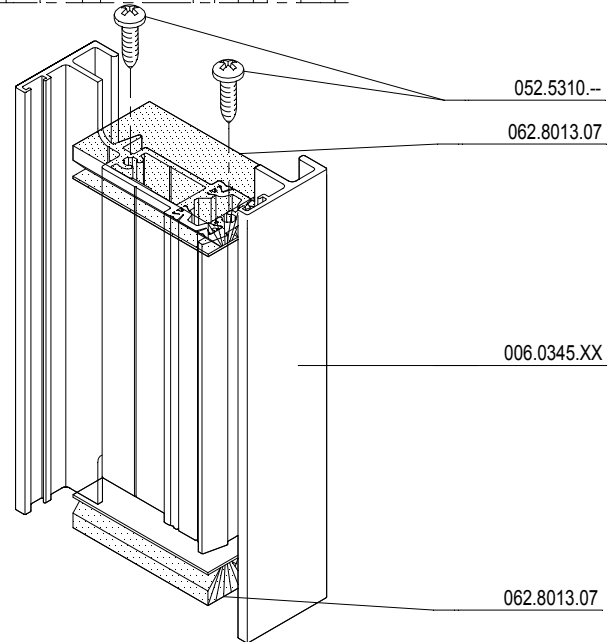
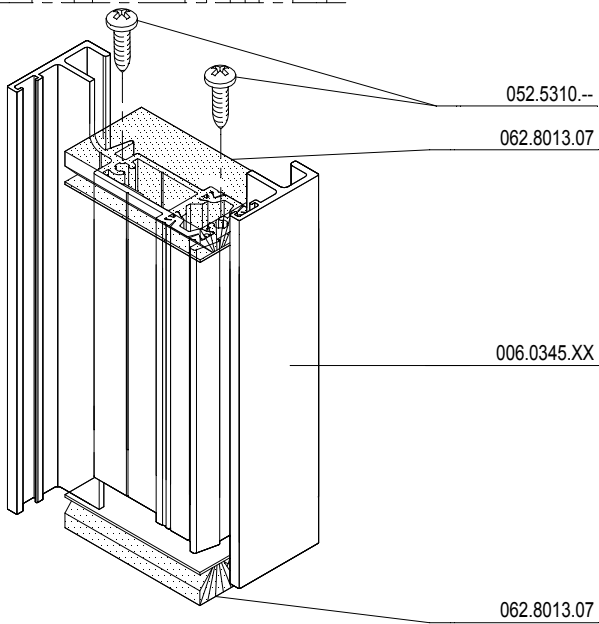
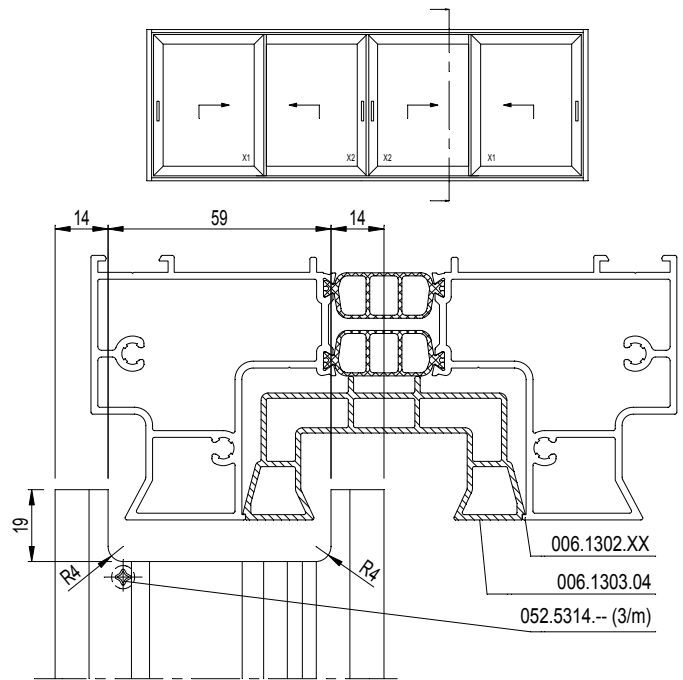
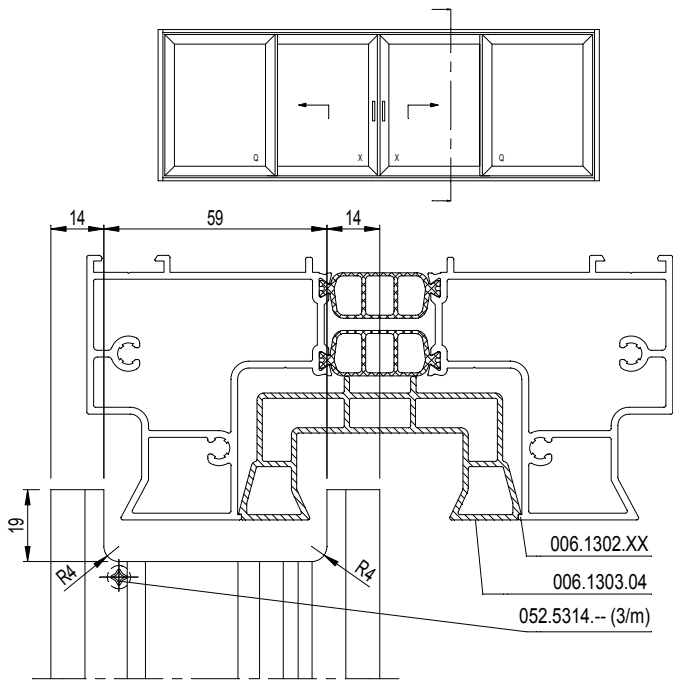

D0013973

MONORAIL QXXQ

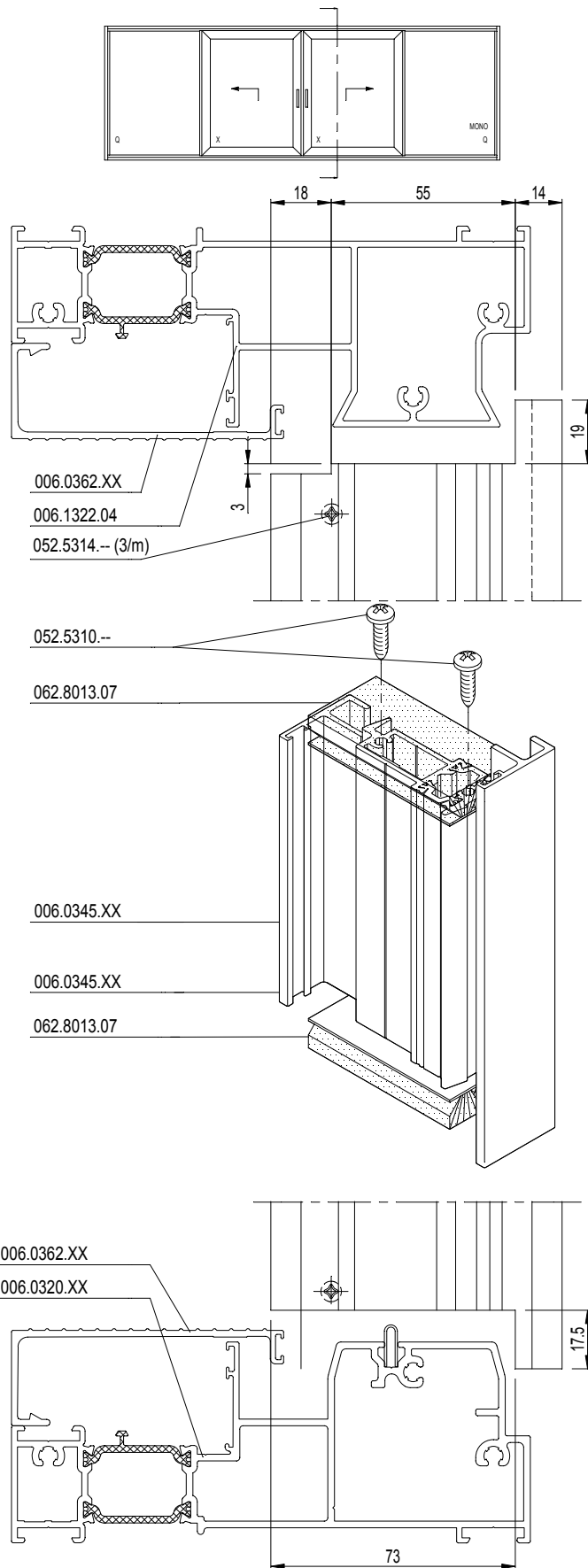

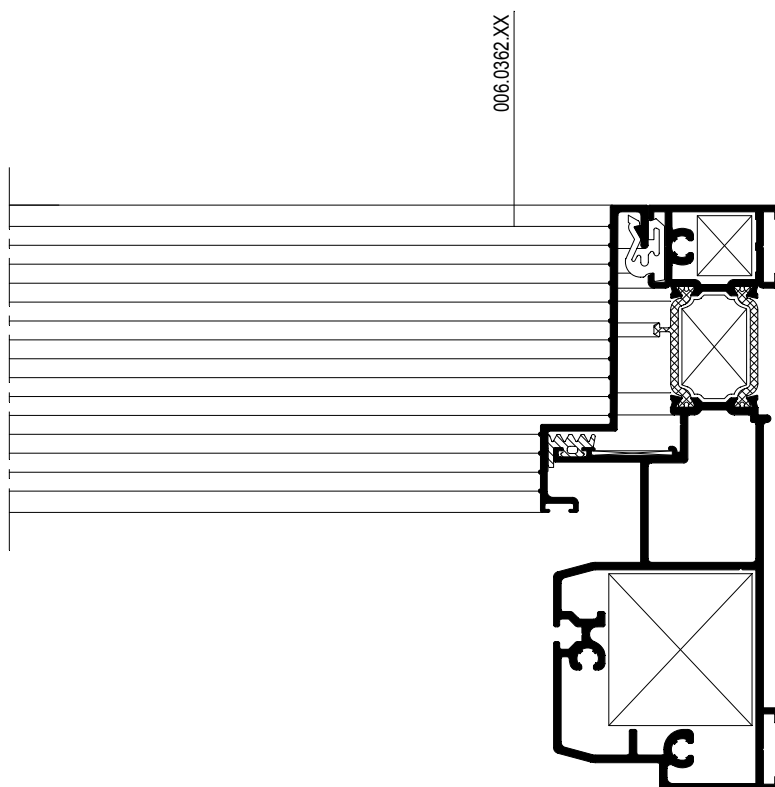
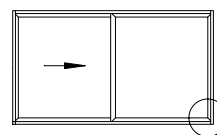

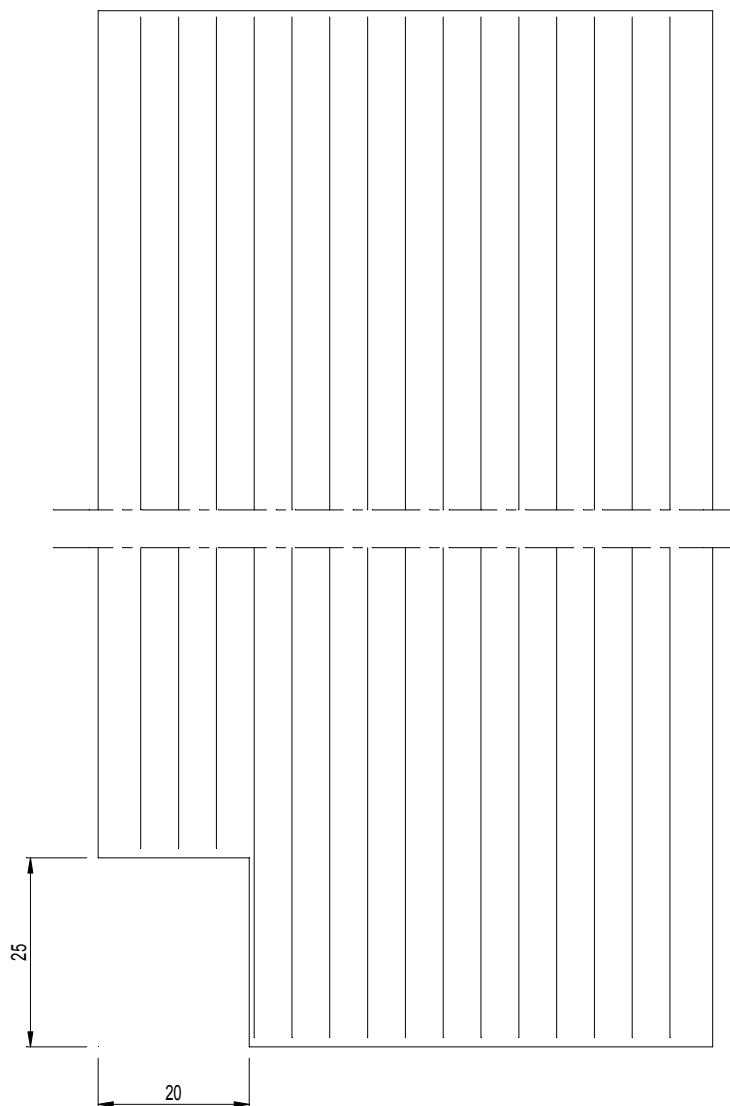
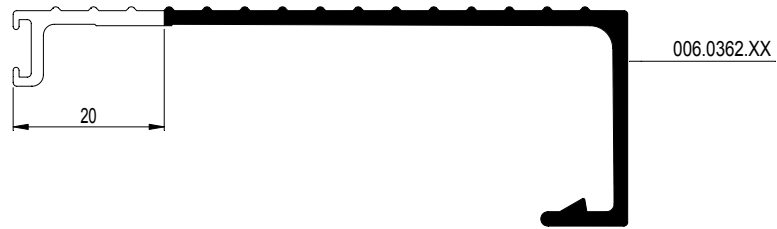

CP 155-LS

BEWERKEN MIDDENSTIJL 2-RAIL QXQ
USINER LIAISON CENTRALE 2-RAIL QXQ
PROCESSING MEETING STILE 2-RAIL QXQ
BEARBEITEN STULPPROFIL 2-RAIL QXQ



TYP QXQ

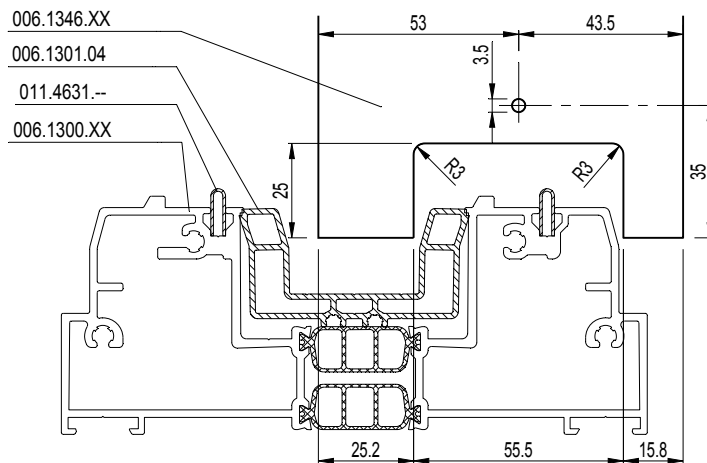
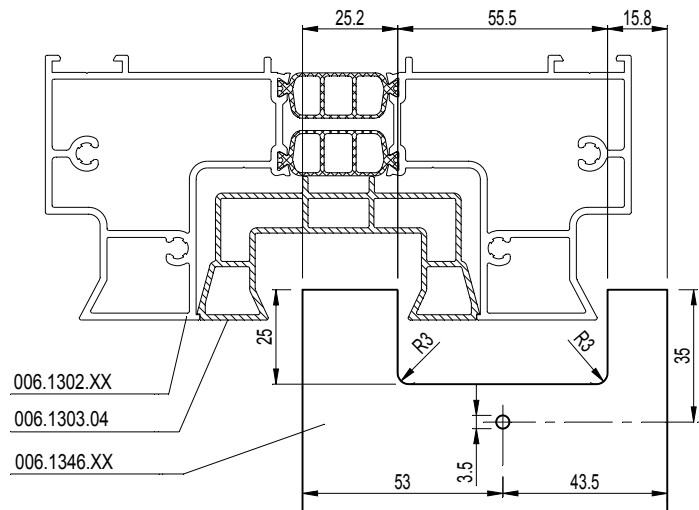
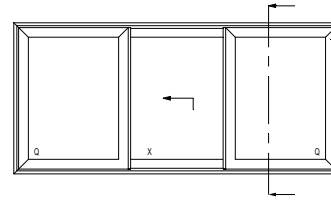

(A)	VLEUGELGEWICHT	MAX. 300KG
	POIDS DU VANTAIL	
	WEIGHT OF THE VENT	
	FLÜGELGEWICHT	

PLAATS VAN DE BUFFER TE BEPALEN MET OPEN VLEUGEL
 PLACE DE LA BUTEE A DETERMINER AVEC OUVRANT OUVERT
 PLACE OF BUFFER TO DETERMINE WITH OPEN VENT
 STELLE DES STOPPERS ZU BESTIMMEN MIT GEÖFFNETEM FLÜGEL

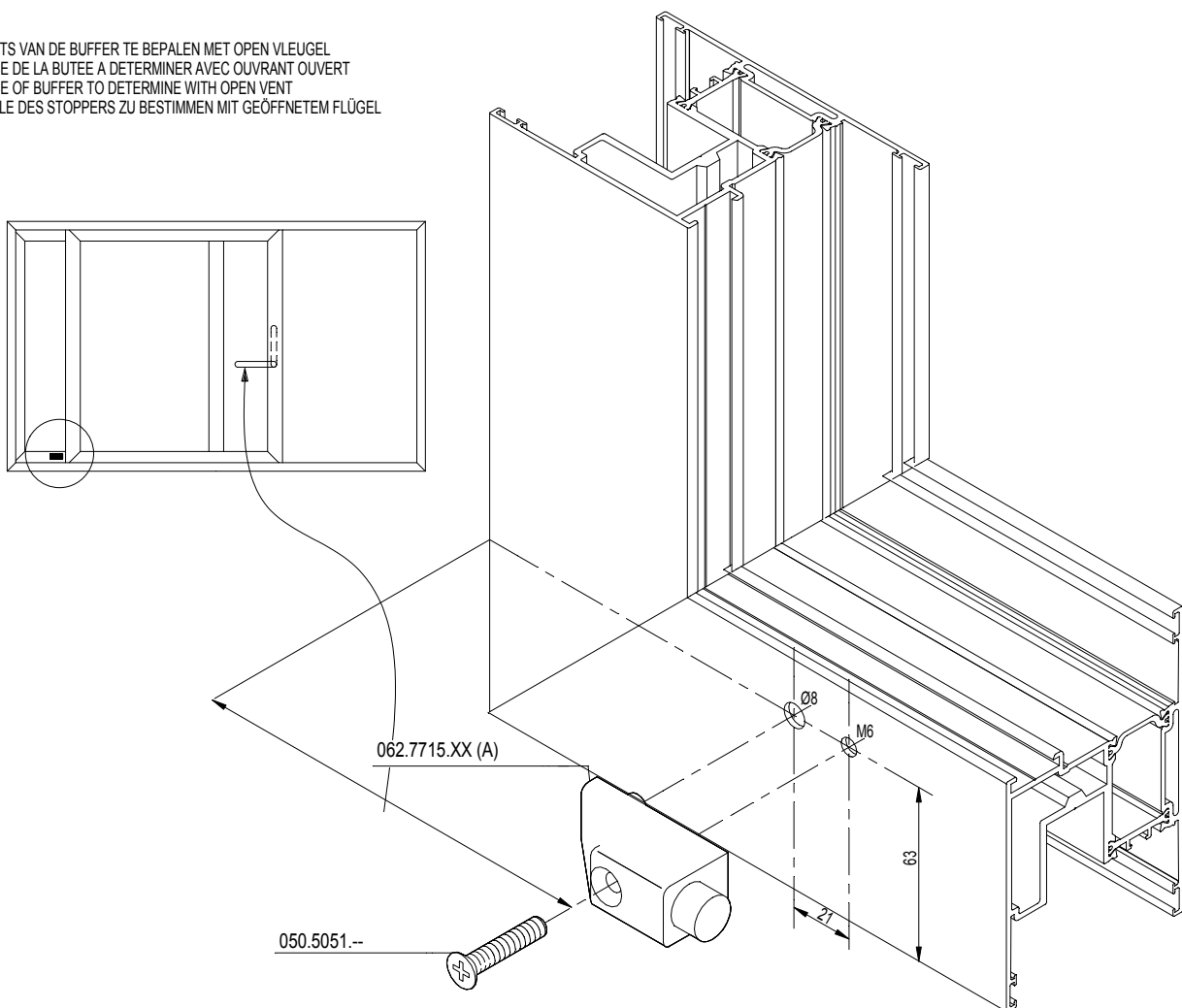

(B)	VLEUGELGEWICHT	MIN. 300KG MAX. 400KG
	POIDS DU VANTAIL	
	WEIGHT OF THE VENT	
	FLÜGELGEWICHT	

PLAATS VAN DE BUFFER TE BEPALEN MET OPEN VLEUGEL
PLACE DE LA BUTEE A DETERMINER AVEC OUVRANT OUVERT
PLACE OF BUFFER TO DETERMINE WITH OPEN VENT
STELLE DES STOPPERS ZU BESTIMMEN MIT GEÖFFNETEM FLÜGEL

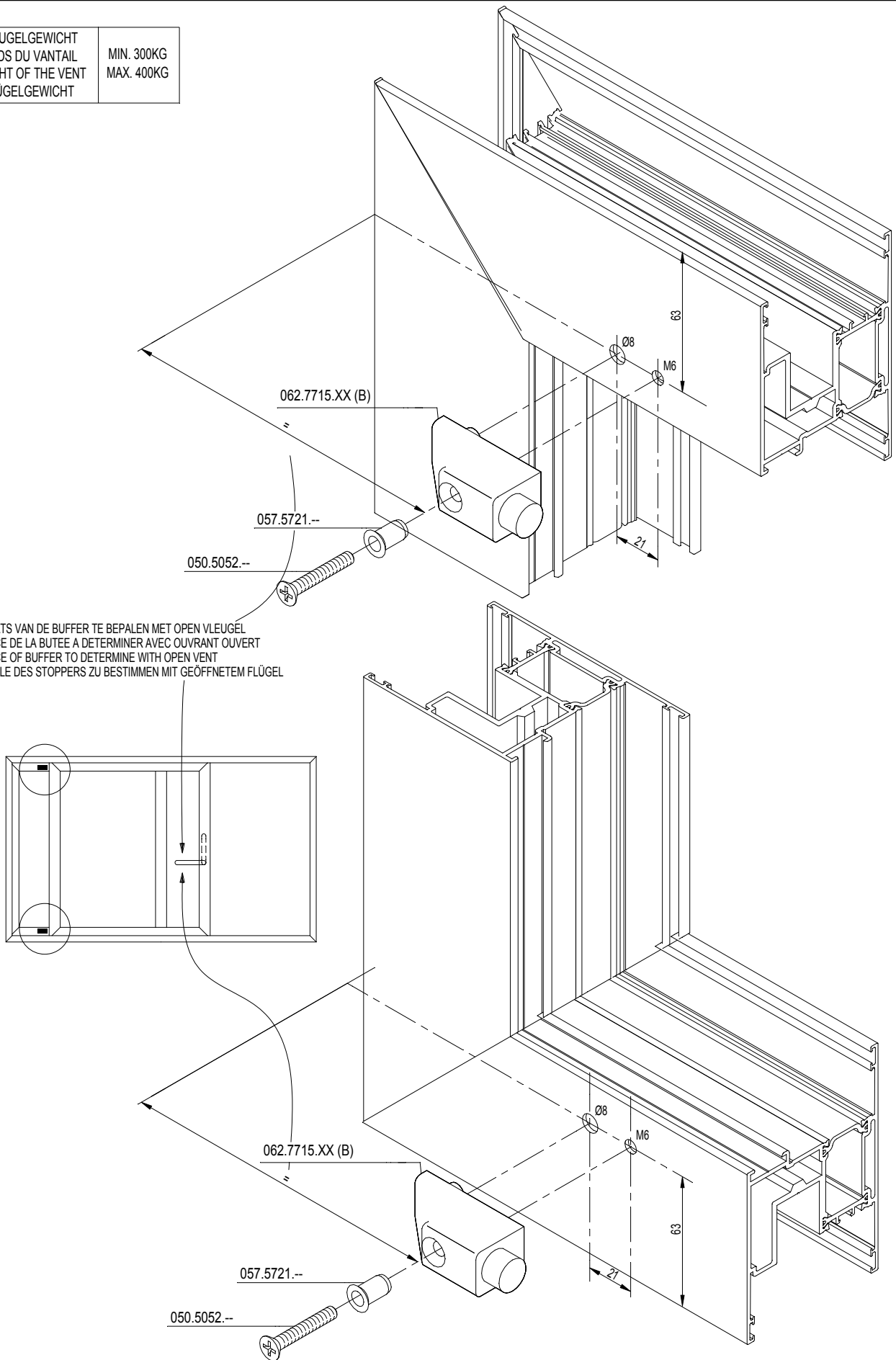

CP 155 CP 155-LS

ONTWATERING VLEUGEL
DRAINAGE OUVRANT
DRAINAGE VENT
ENTWÄSSERUNG FLUEGEL

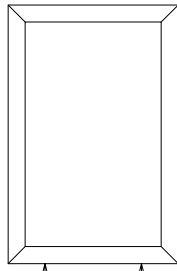

ONTWATERING Ø8 IN DE VLEUGELS
DRAINAGE Ø8 DANS LES OUVRANTS
DRAINING Ø8 IN THE VENTS
ENTWÄSSERUNG Ø8 IN DEN FLÜGELN

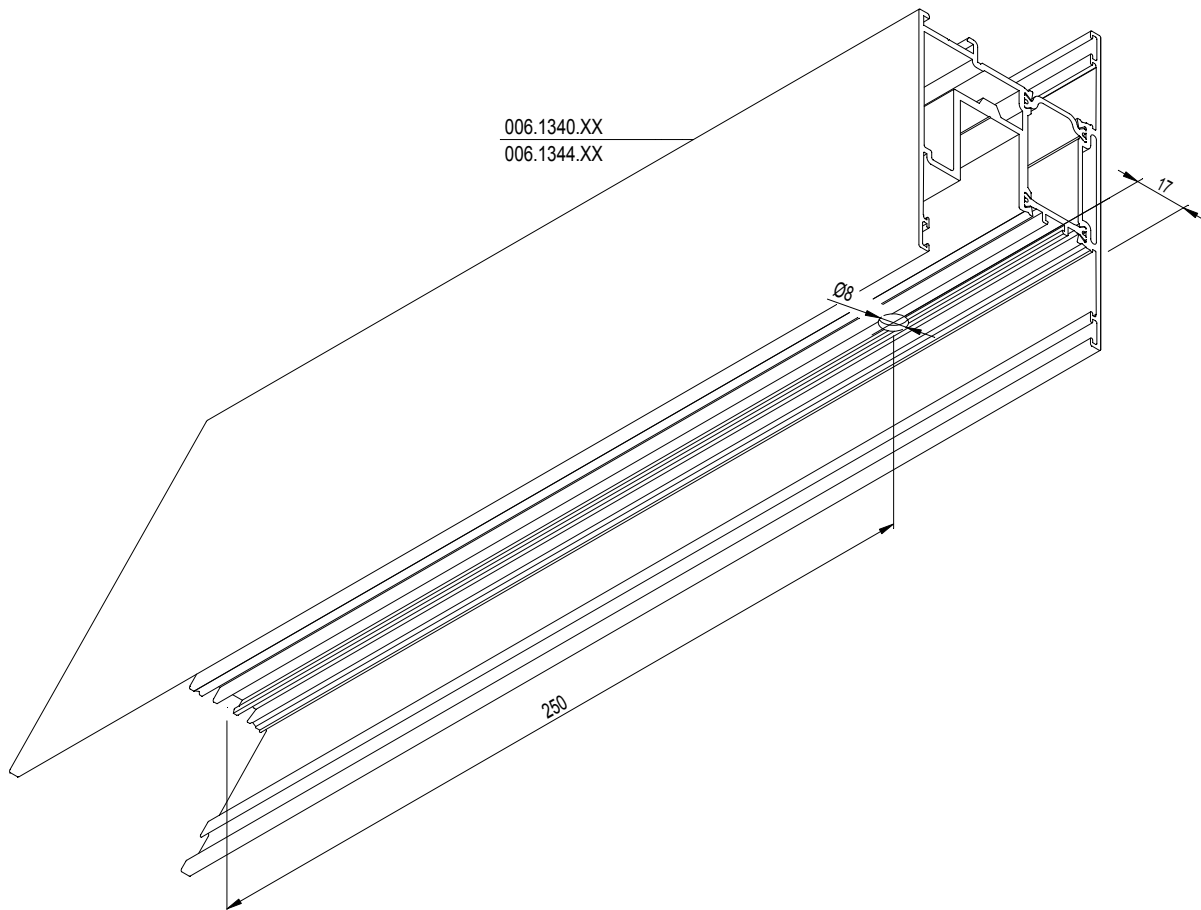
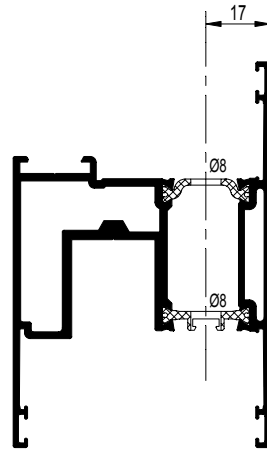

DECOMPRESSIE Ø5 IN DE VLEUGELS
DECOMPRESSION Ø5 DANS LES OUVRANTS
DECOMPRESSION Ø5 IN THE VENTS
DEKOMPRESSIÖN Ø5 IN DEN FLÜGELN

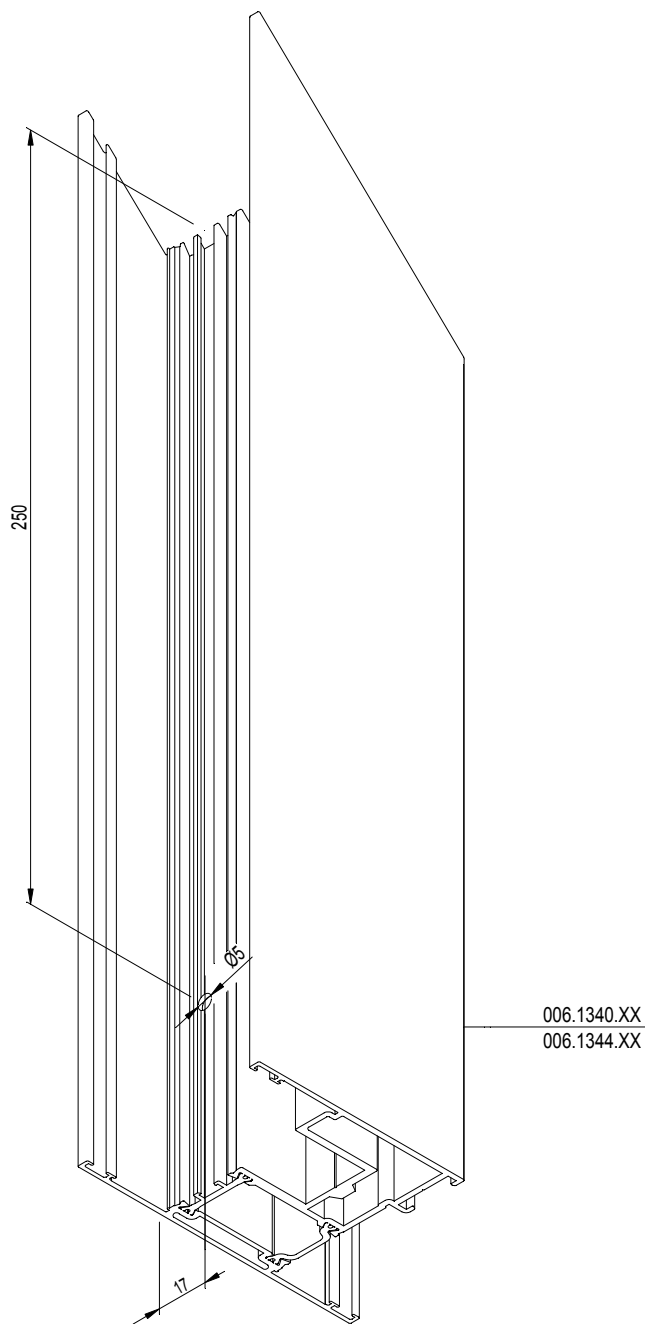
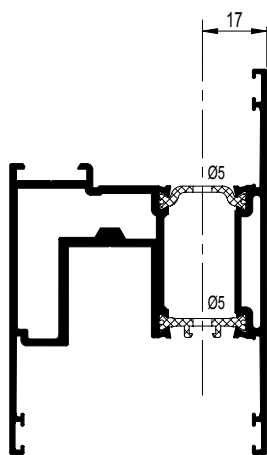
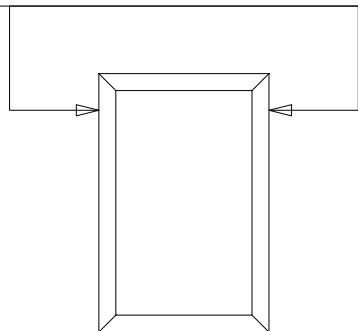

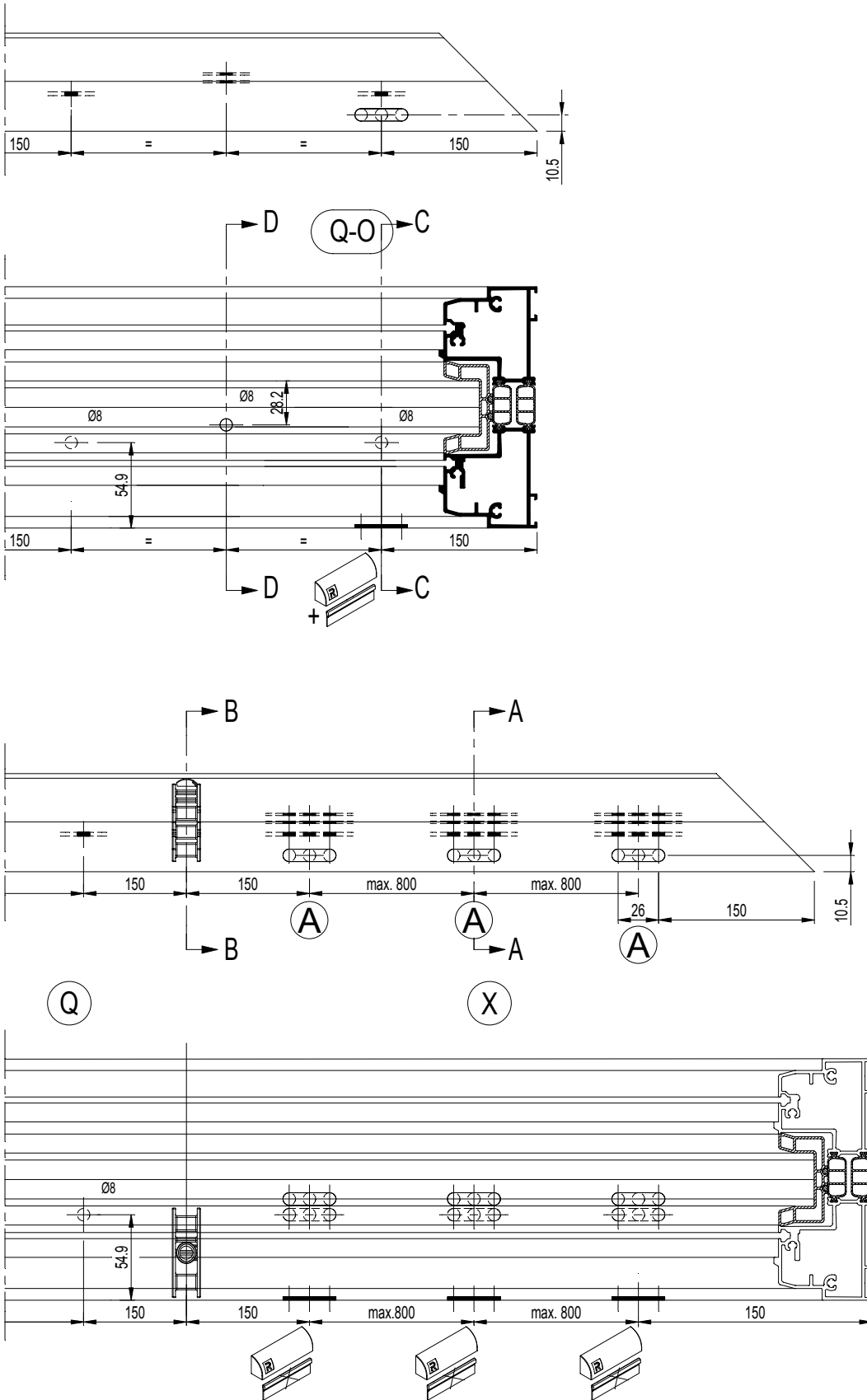

TYPE QXQ

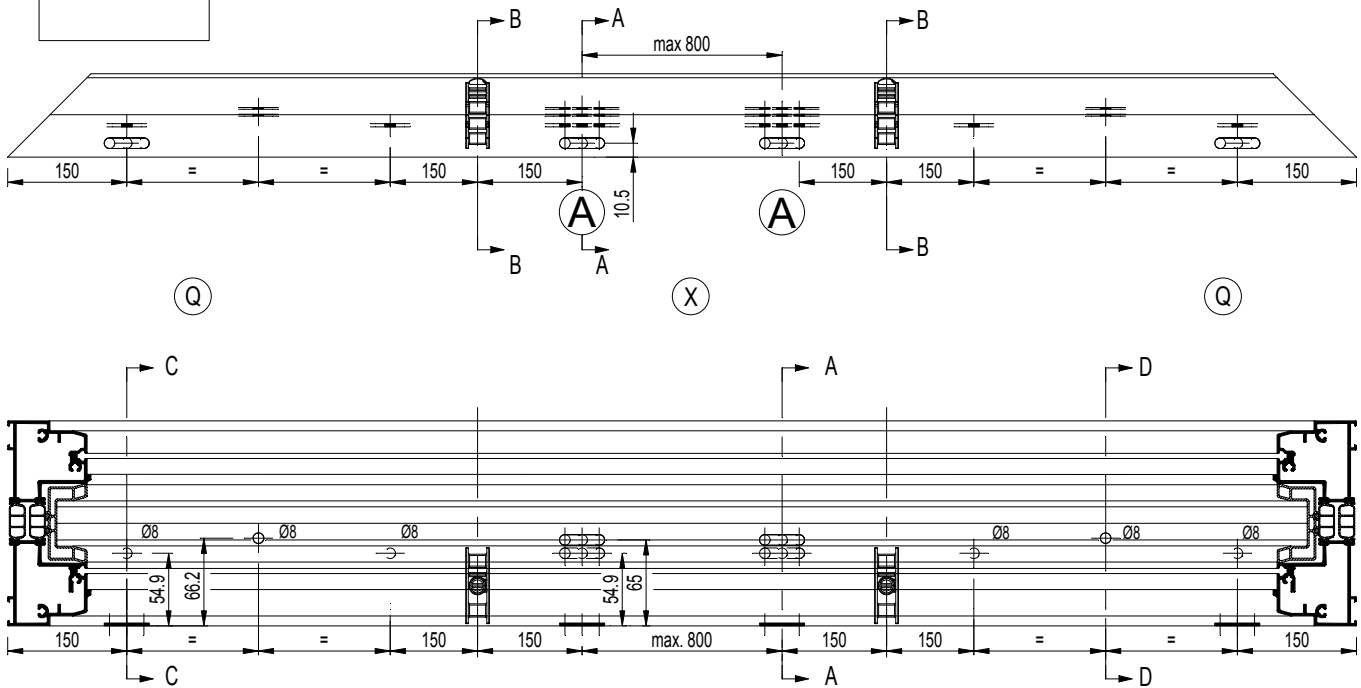

TYPE QXXQ
 TYPE OXXO

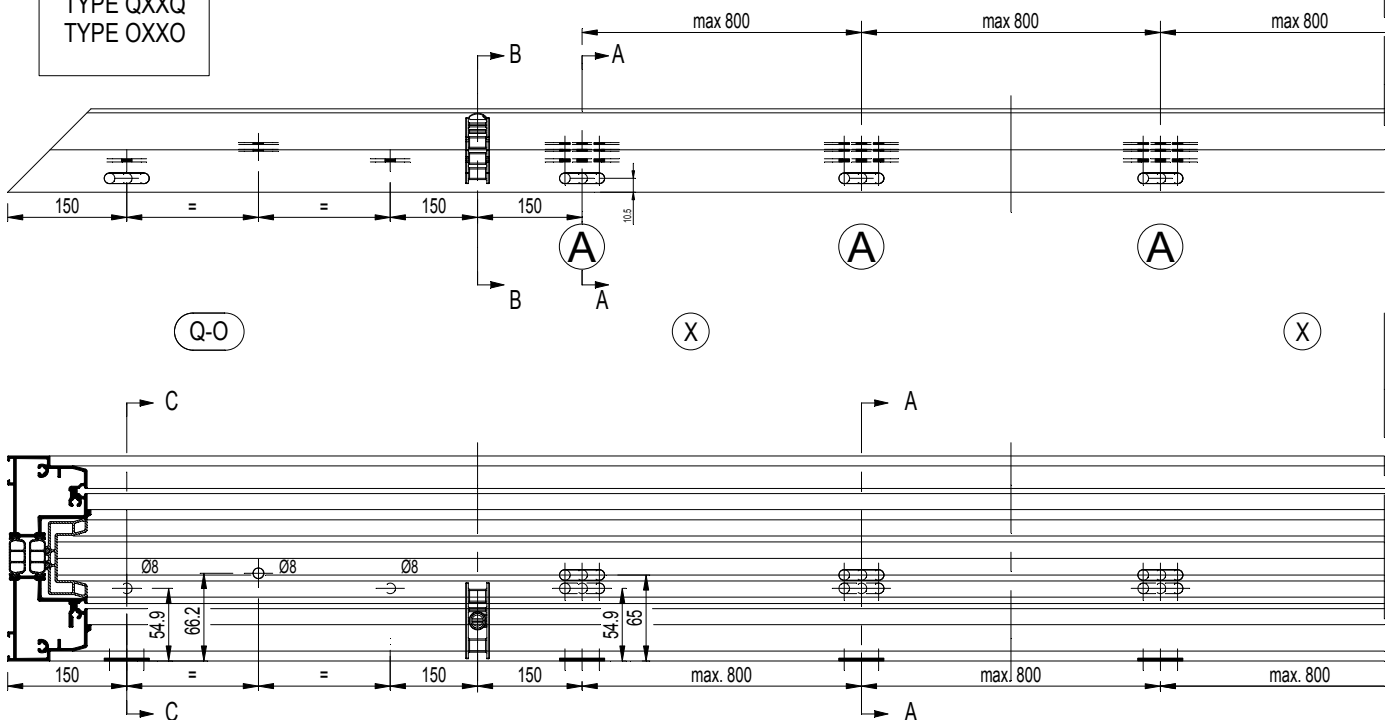

BOORMAL
 CALIBRE DE PERÇAGE
 BORING JIG
 BOHRLEHRE

097.0437.00



D0013978

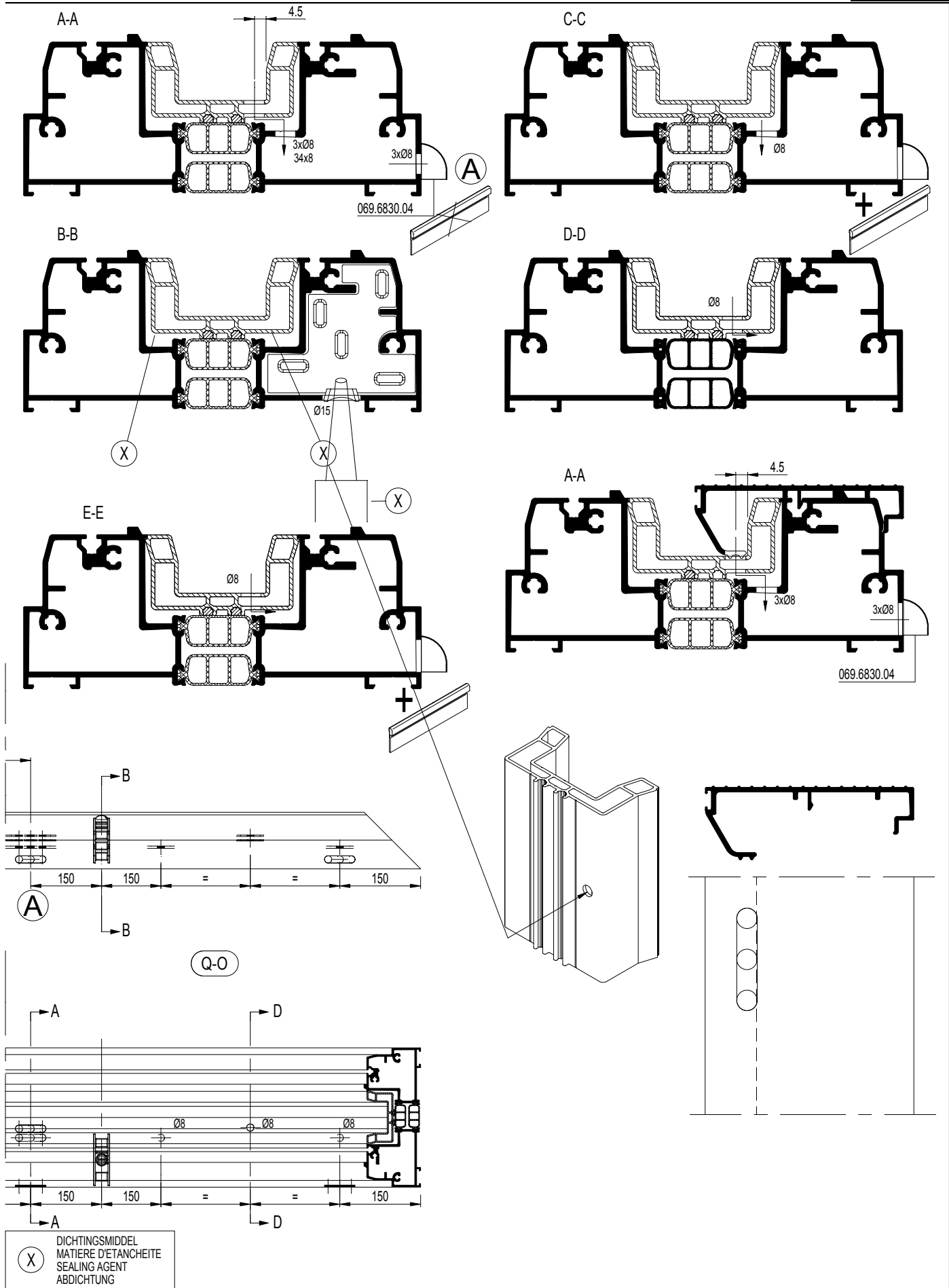

TYPE XQ
 TYPE XX

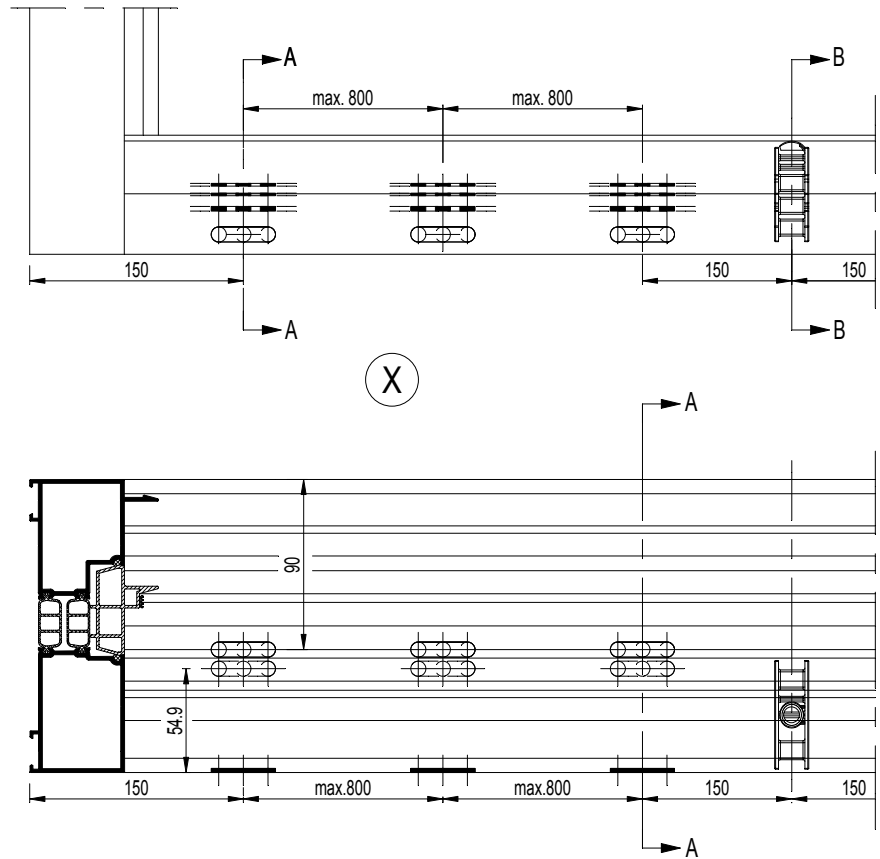

TYPE XQX

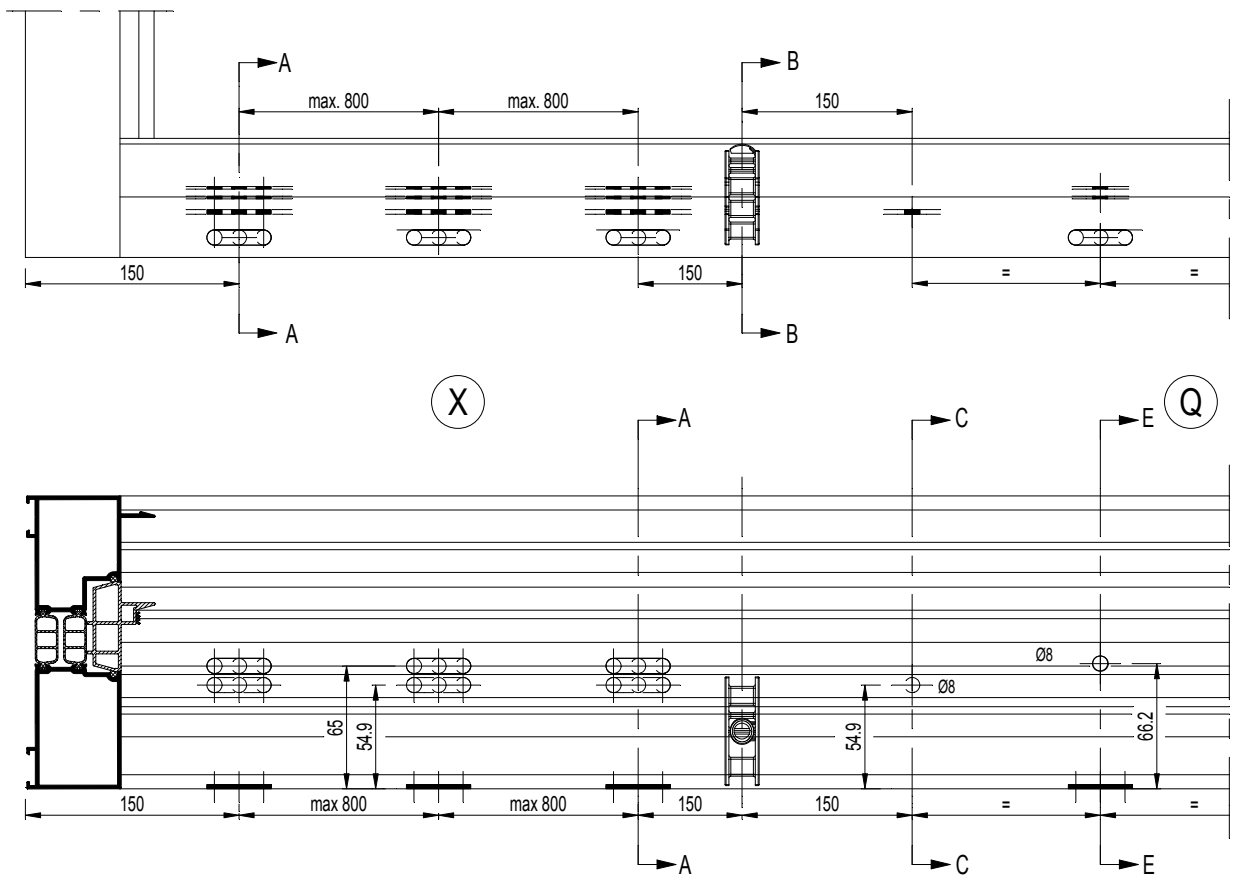

D0013979

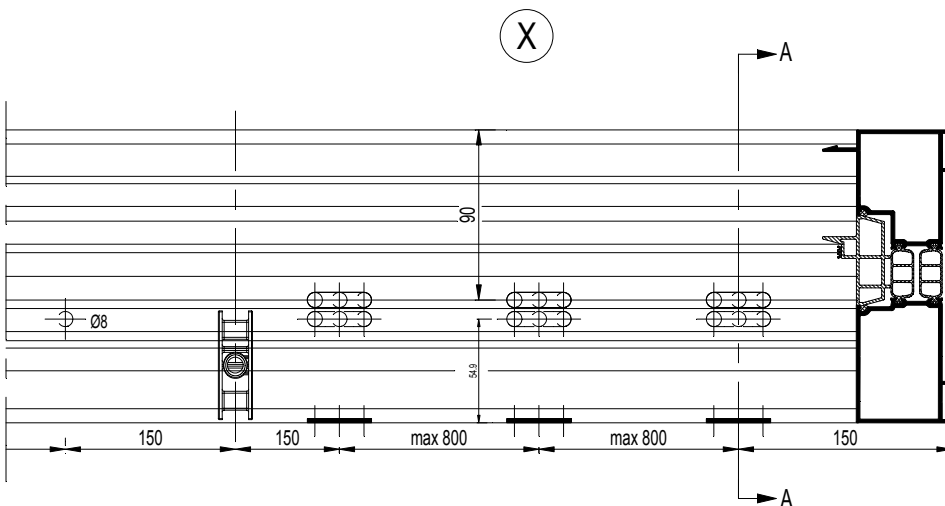
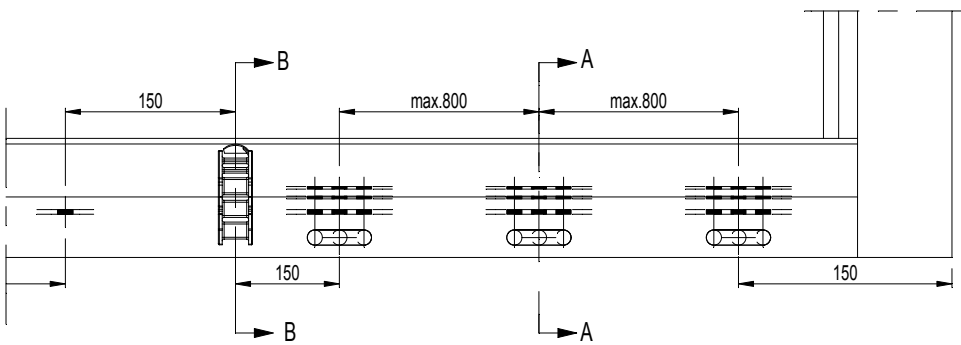
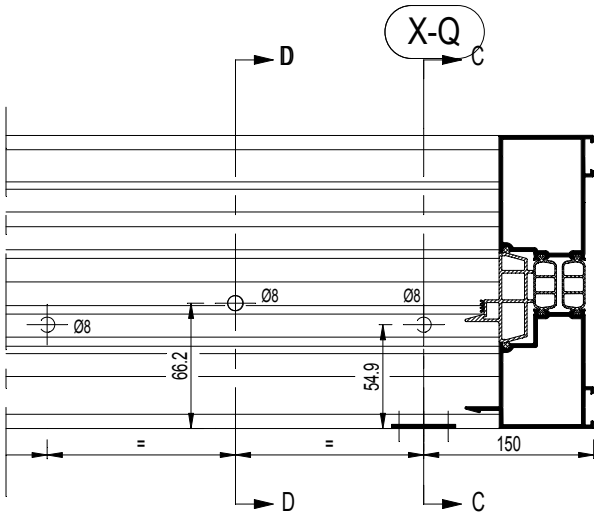
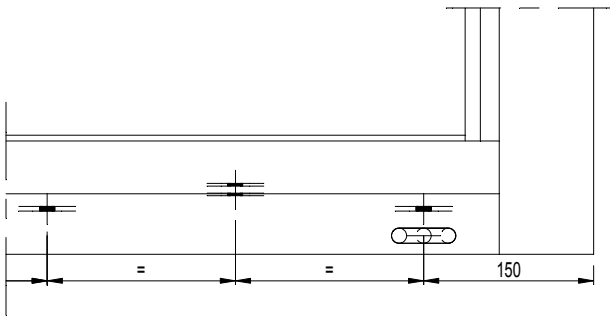

CP 155-LS

ONTWATERING TYPE QXQ QXXQ OXXO
 DRAINAGE TYPE QXQ QXXQ OXXO
 DRAINAGE TYPE QXQ QXXQ OXXO
 ENTWAESSERUNG TYP QXQ QXXQ OXXO

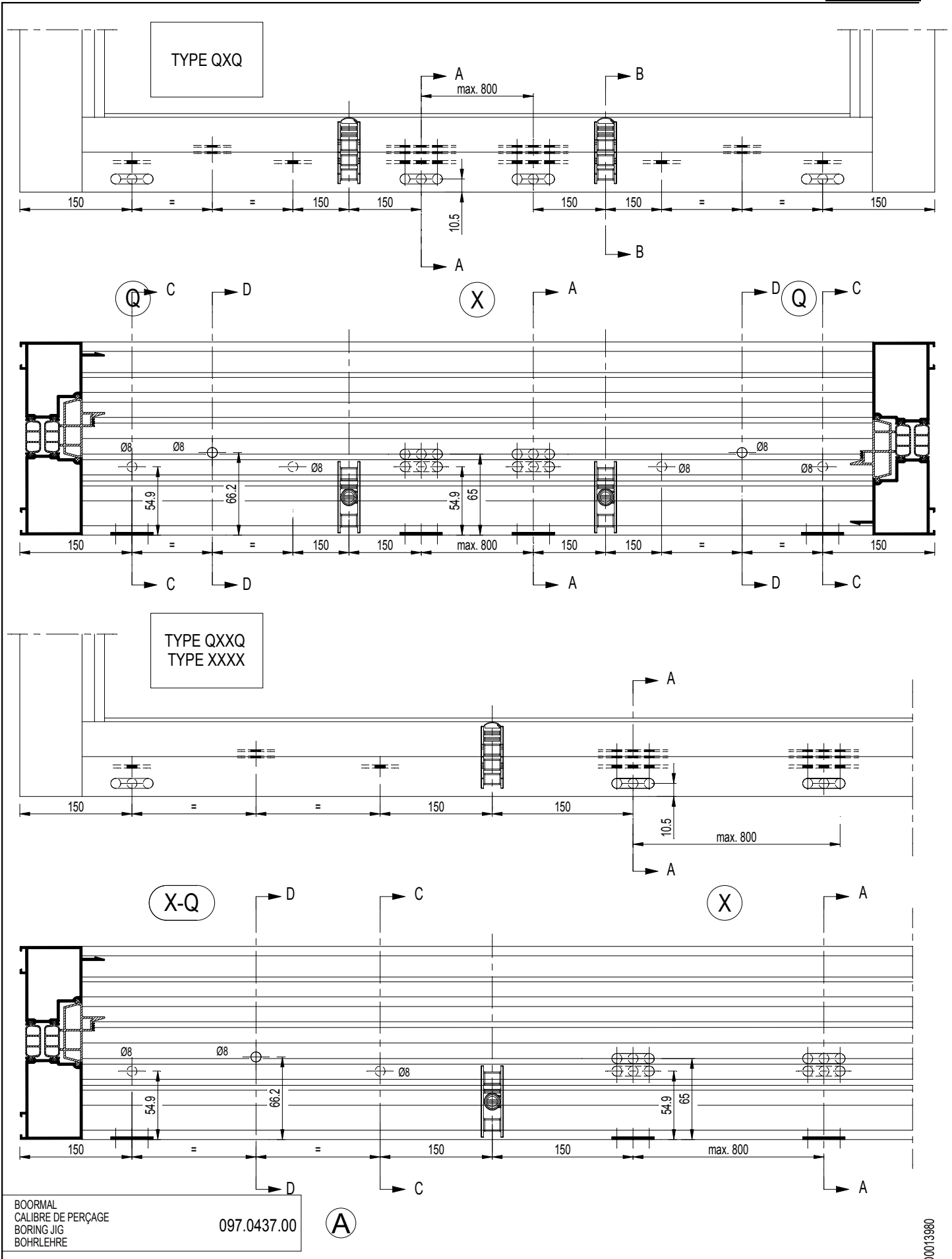

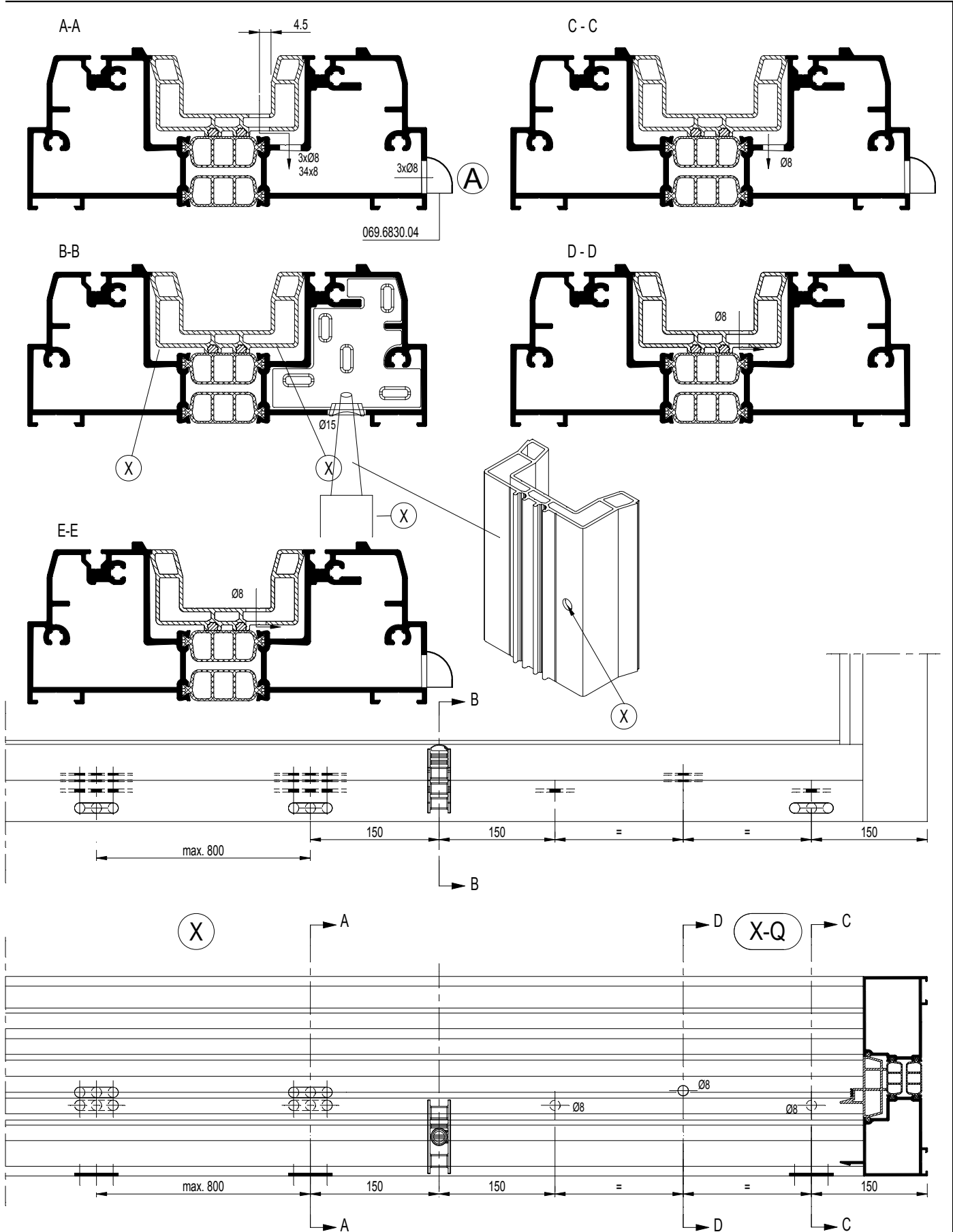

DECOMPRESSIE IN VAST RAAM MONORAIL
 DECOMPRESSION DANS CHASSIS FIXE MONORAIL
 DECOMPRESSION IN FIXED WINDOW MONORAIL
 DEKOMPRESSIE IN DER FESTVERGLASUNG MONORAIL

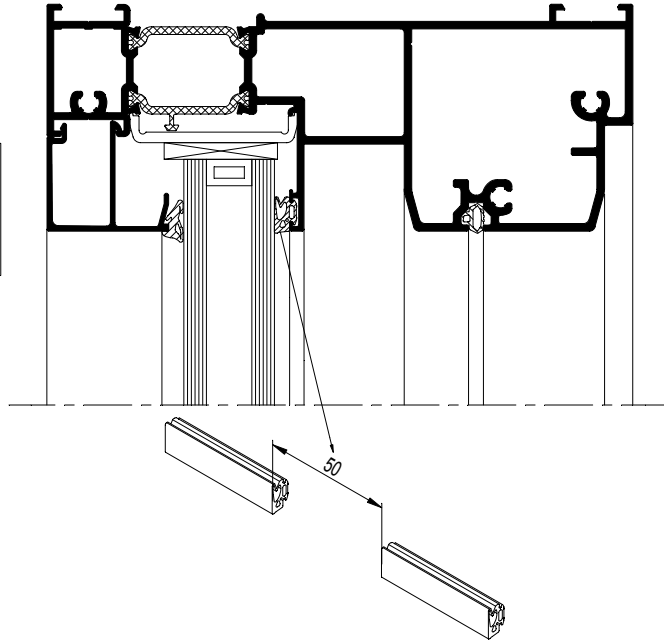
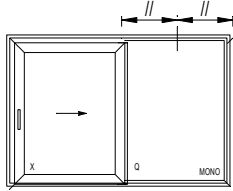

TYPE XQ

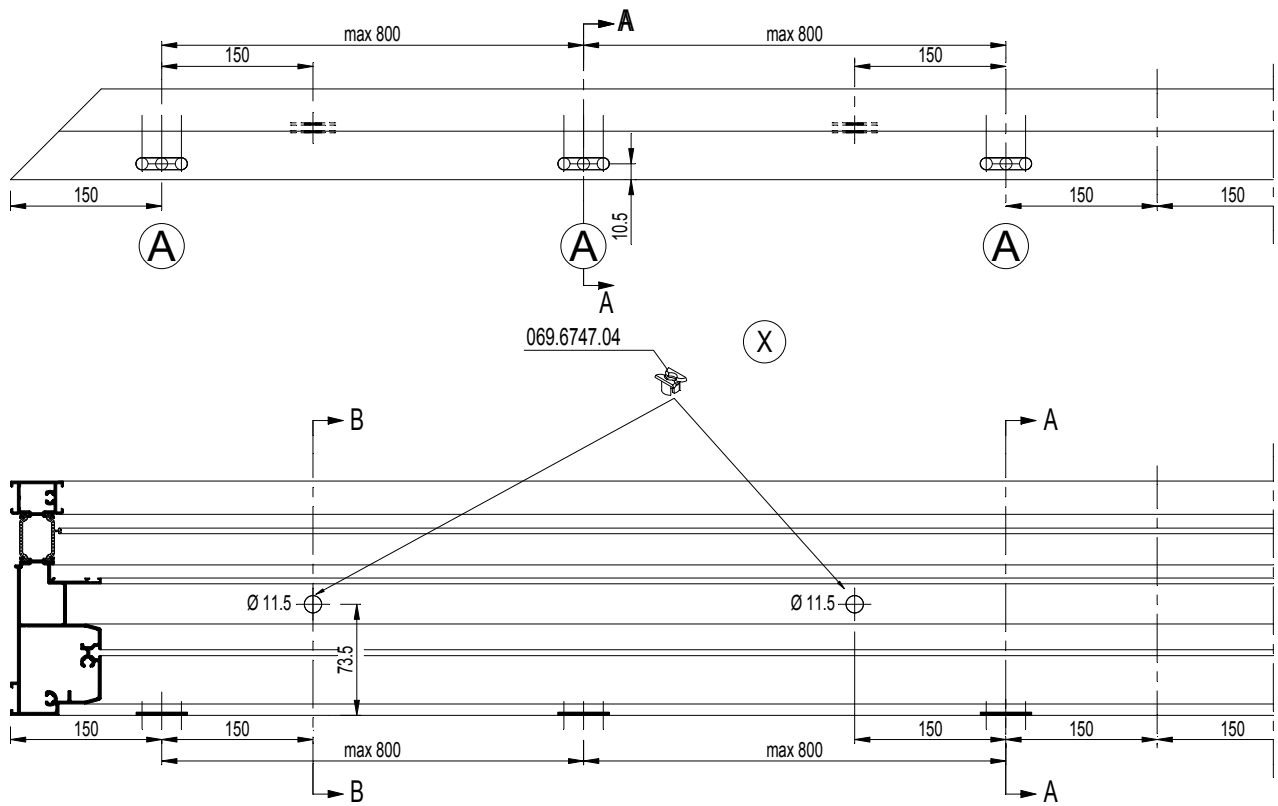

BOORMAL
 CALIBRE DE PERÇAGE
 BORING JIG
 BOHRLEHRE

097.0437.00



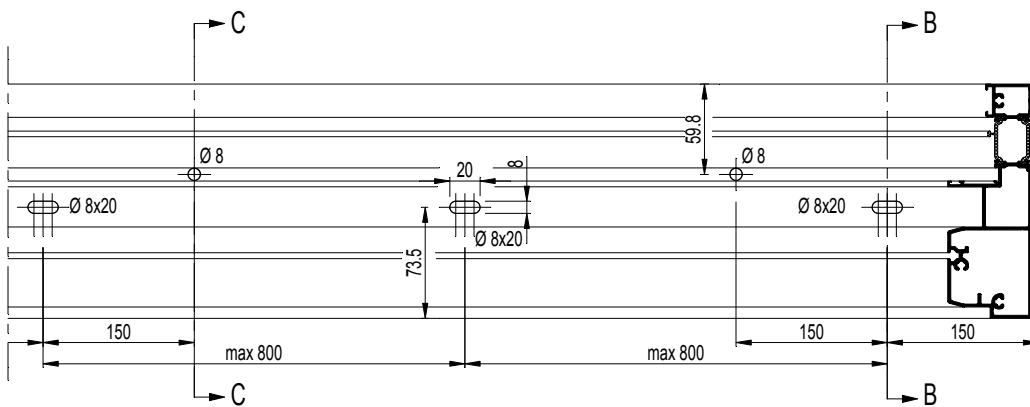
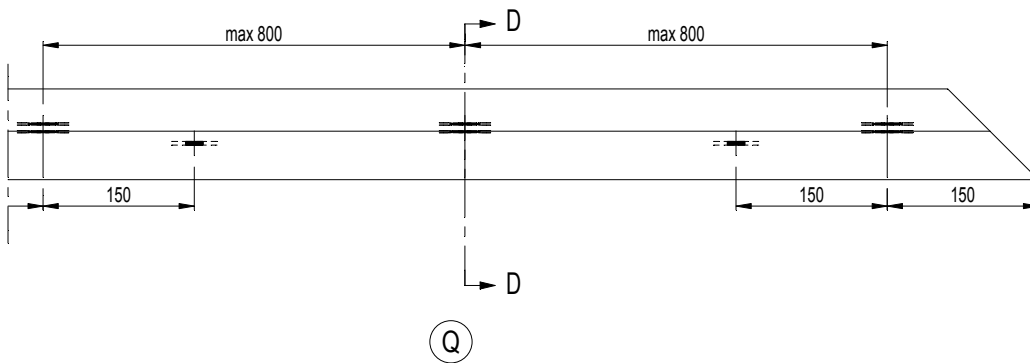
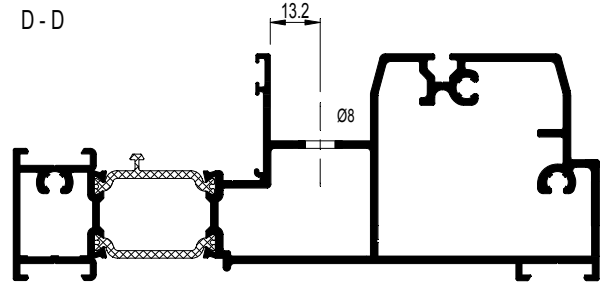
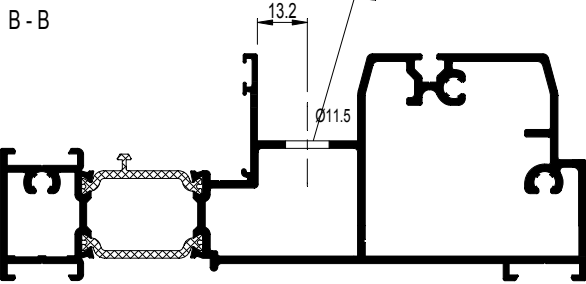
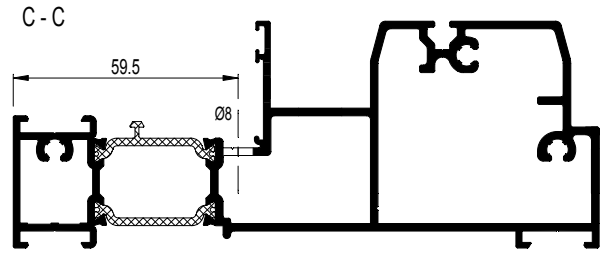
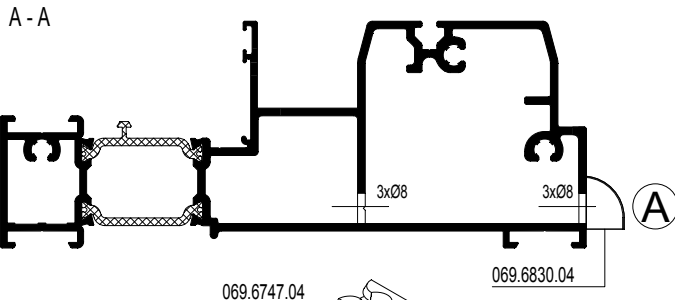

TYPE XQX

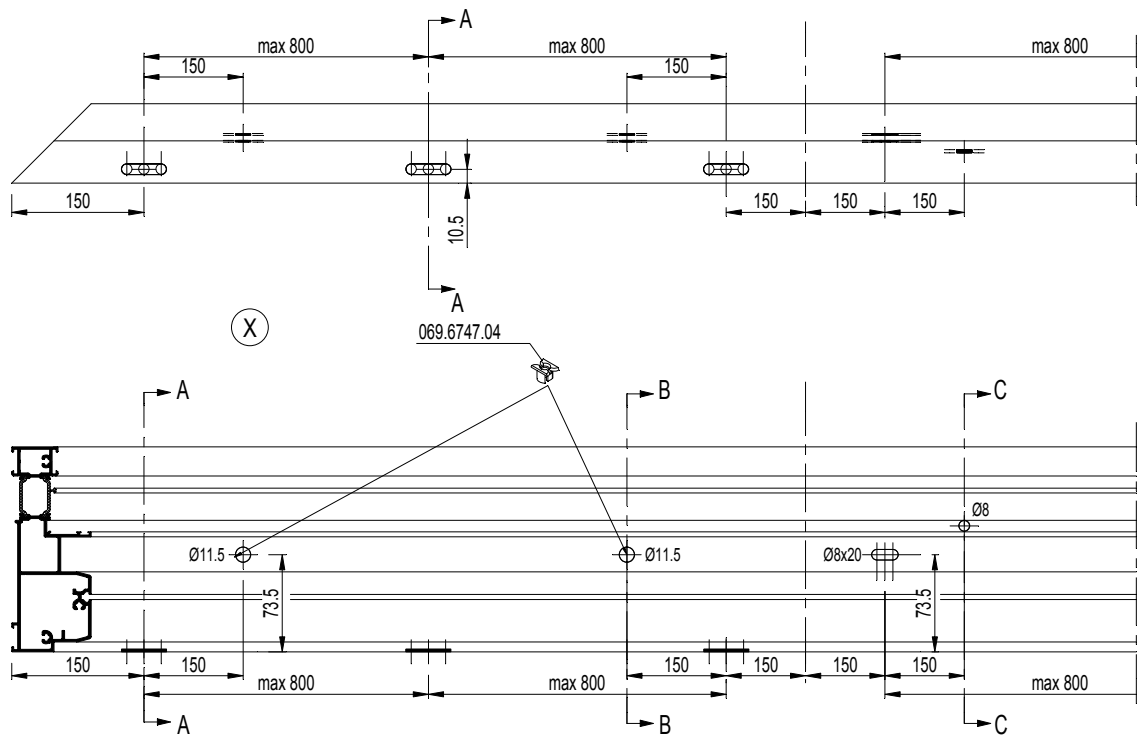

BOORMAL
 CALIBRE DE PERÇAGE
 BORING JIG
 BOHRLEHRE

097.0437.00

(A)

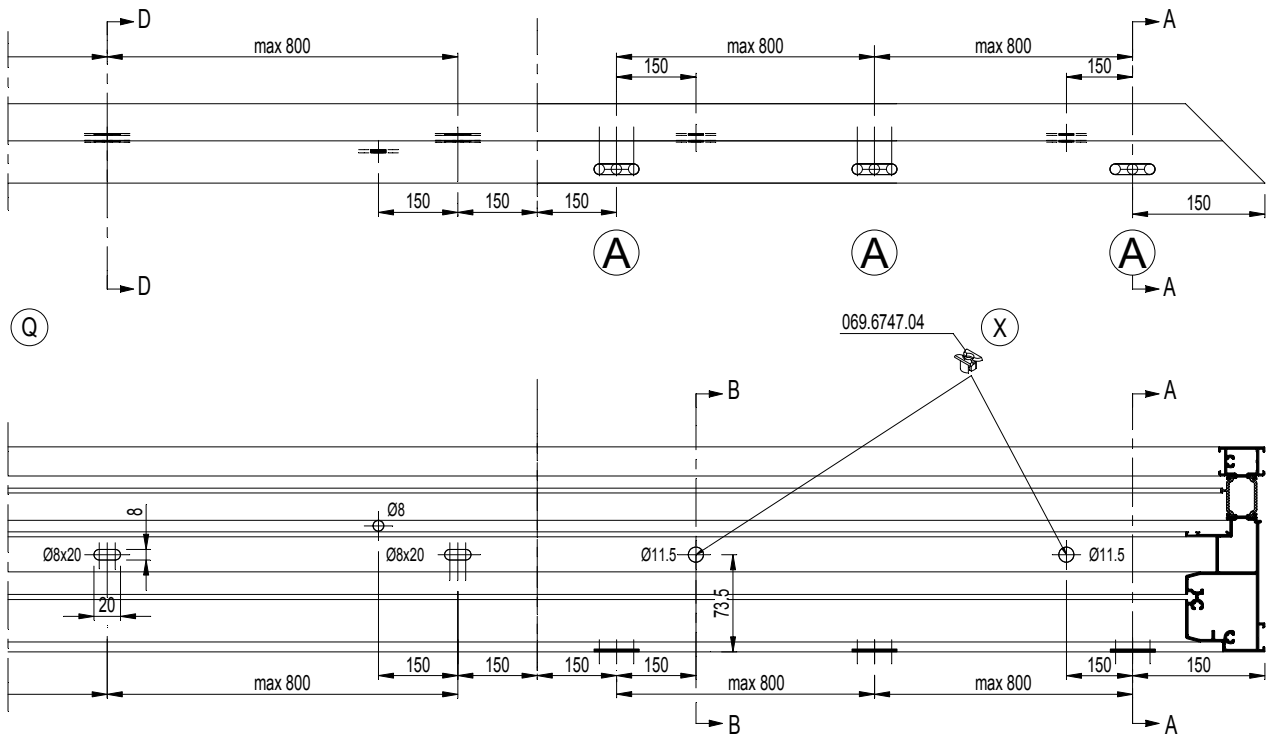
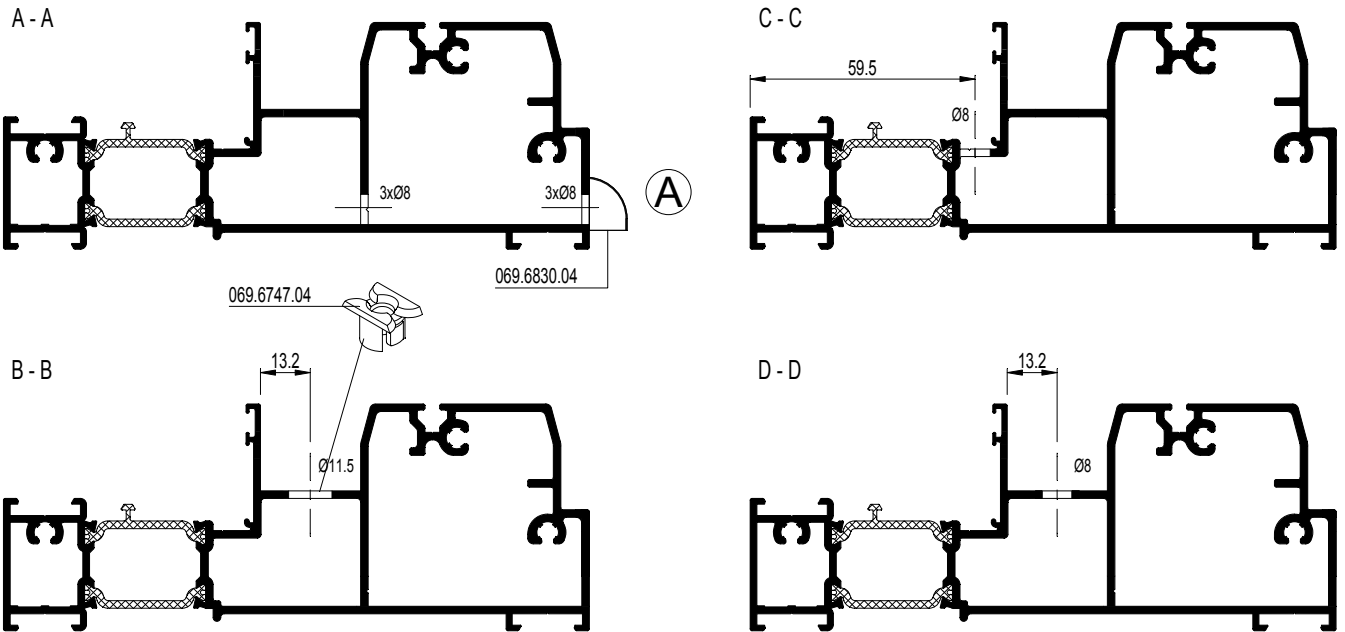

TYPE QXXQ

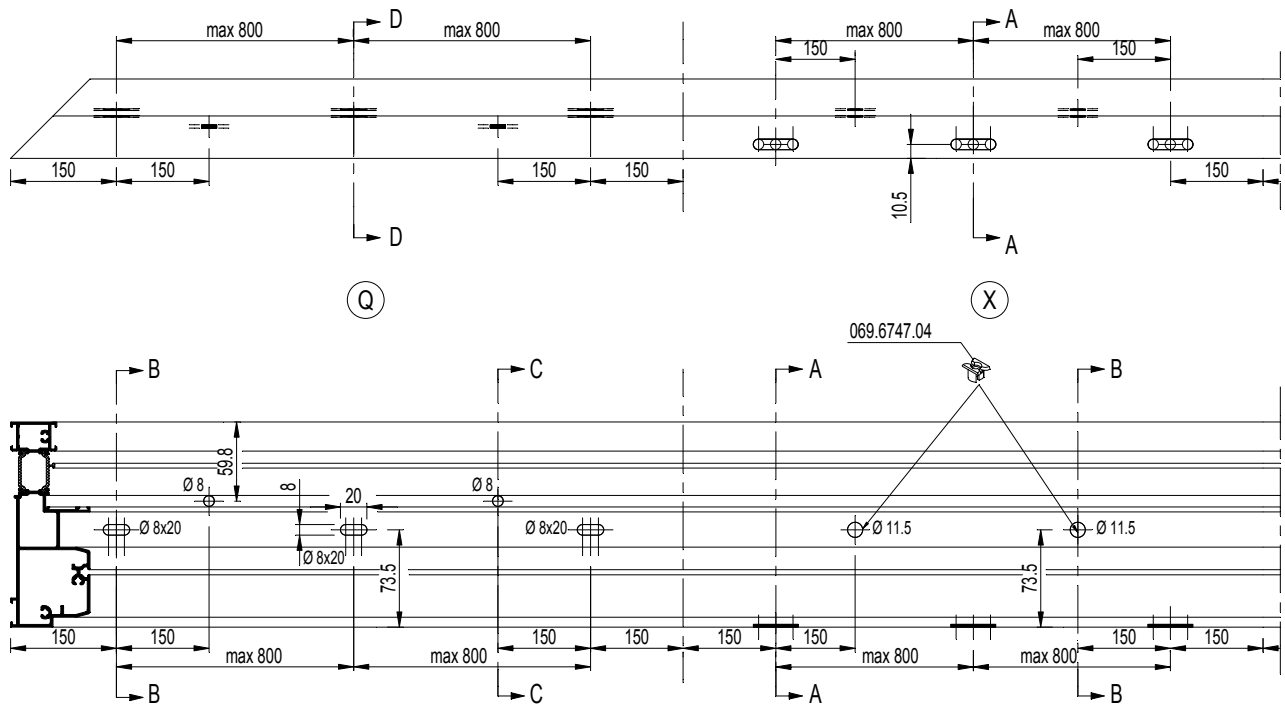

BOORMAL
 CALIBRE DE PERÇAGE
 BORING JIG
 BOHRLEHRE

097.0437.00

A

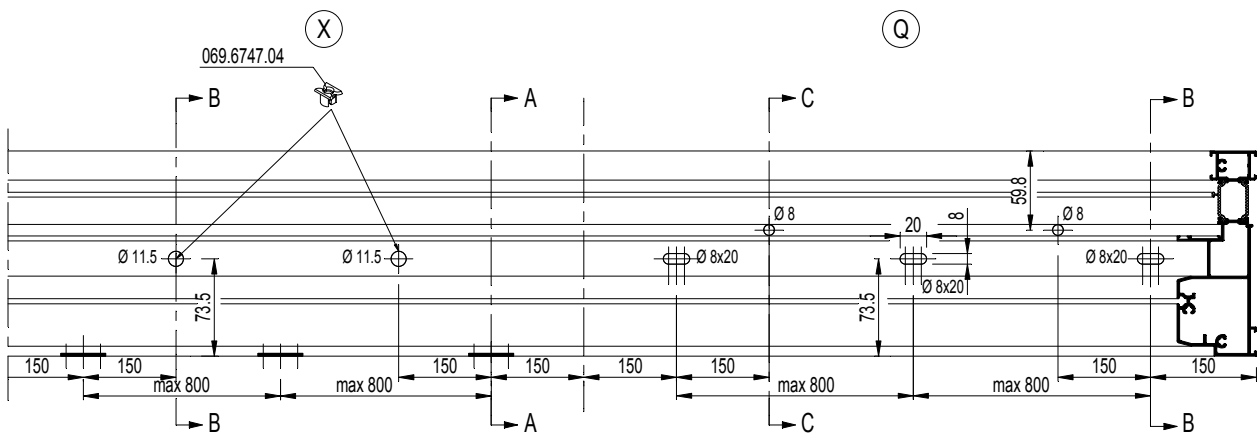
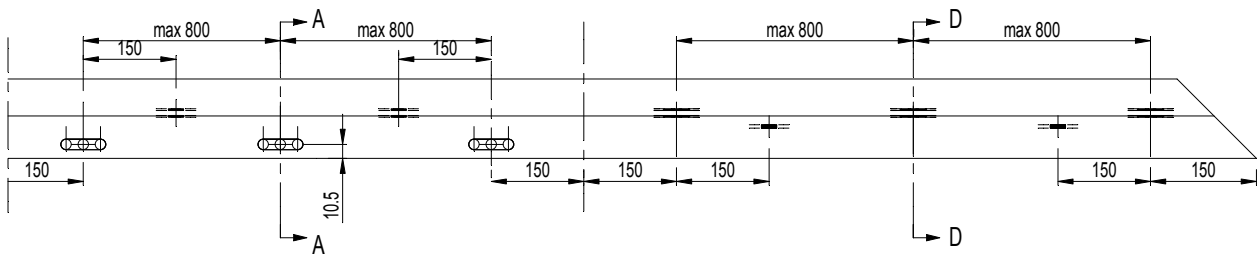
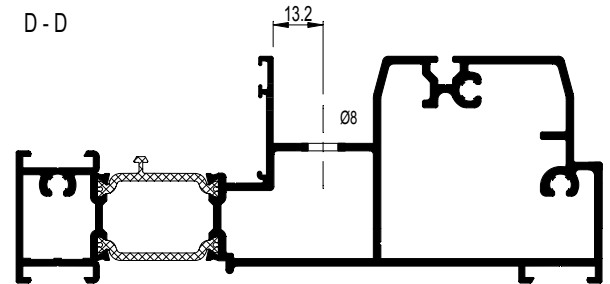
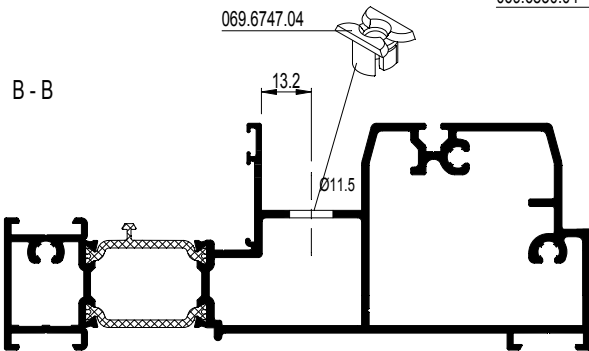
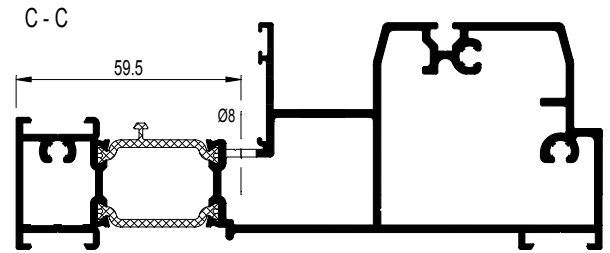
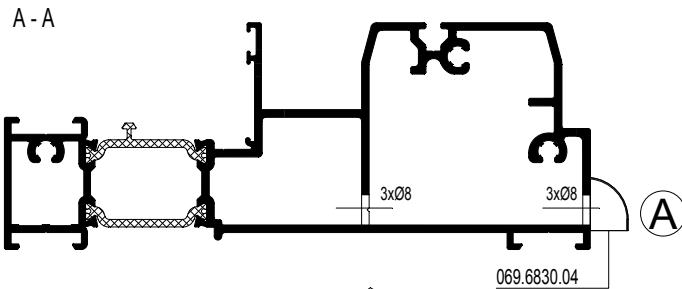

DECOMPRESSIE IN VAST RAAM MONORAIL
 DECOMPRESSION DANS CHASSIS FIXE MONORAIL
 DECOMPRESSION IN FIXED WINDOW MONORAIL
 DEKOMPRESSION IN DER FESTVERGLASUNG MONORAIL

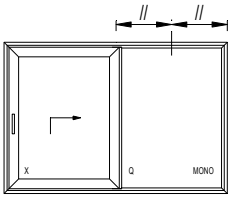
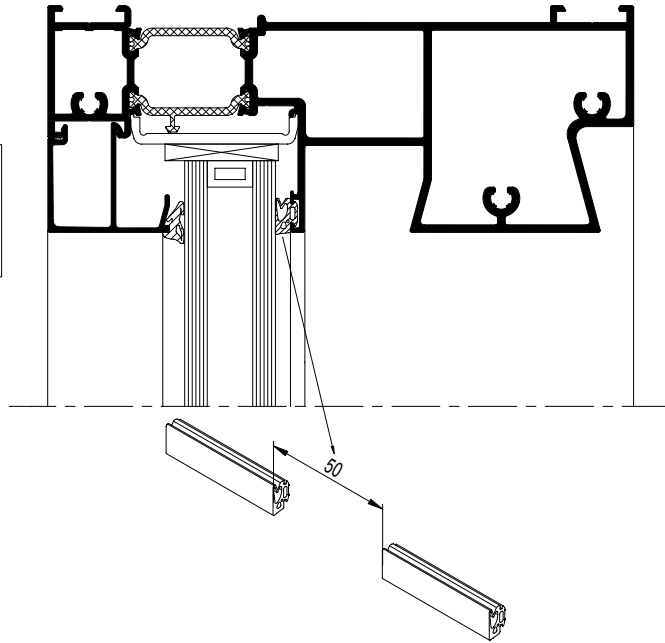

TYPE XQ

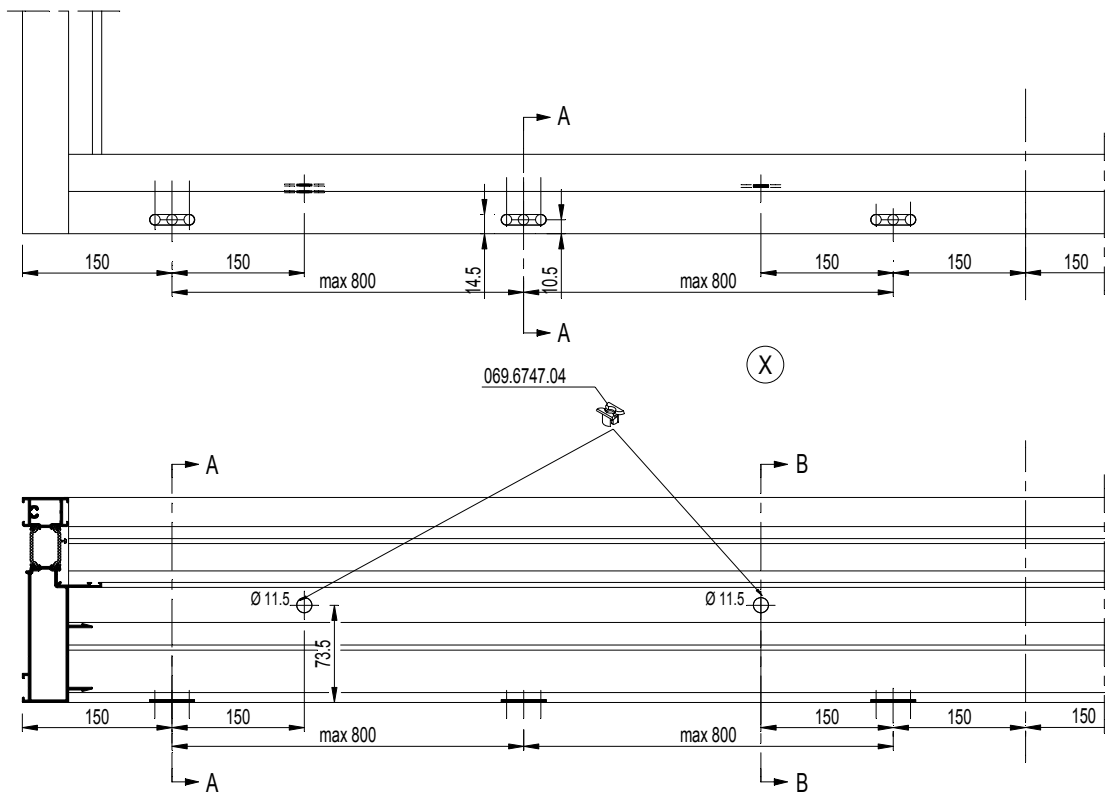

BOORMAL
 CALIBRE DE PERÇAGE
 BORING JIG
 BOHRLEHRE

097.0437.00



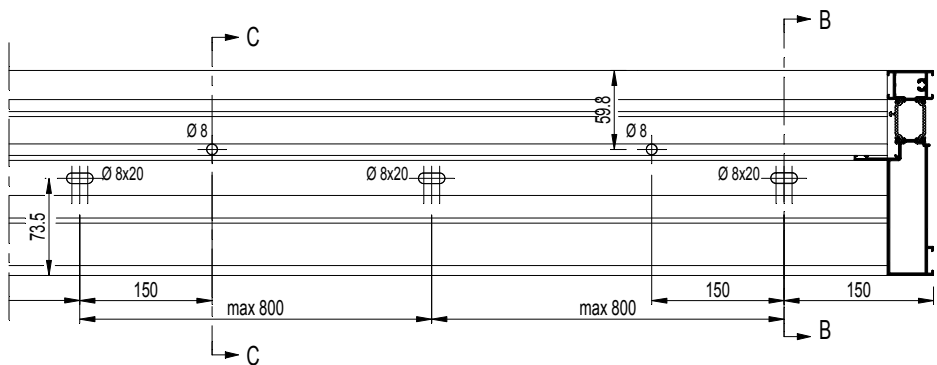
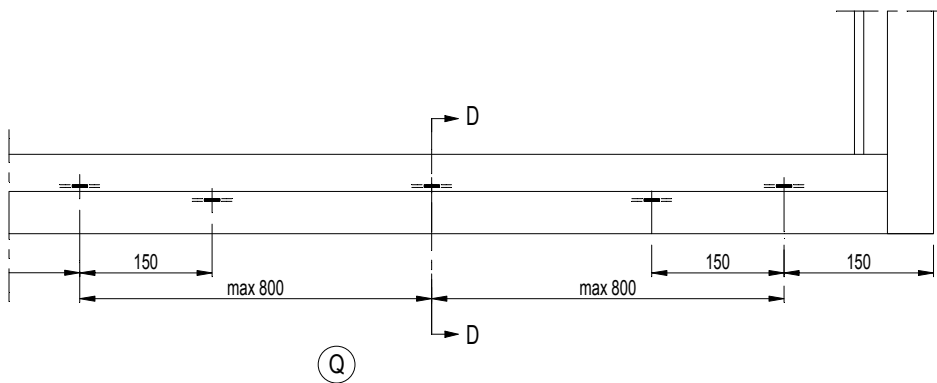
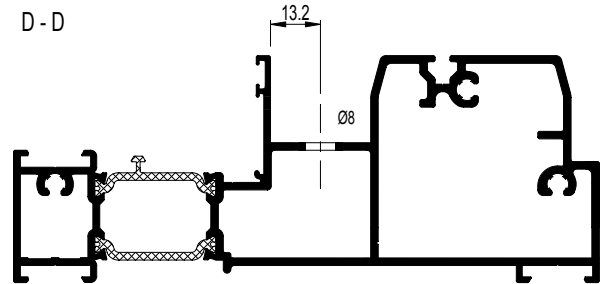
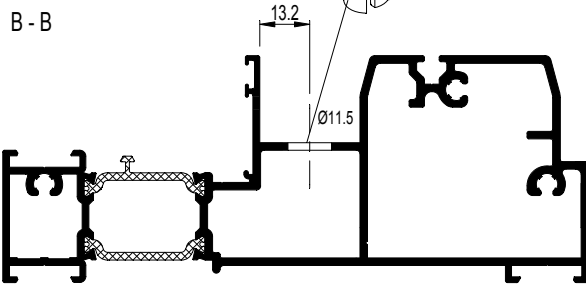
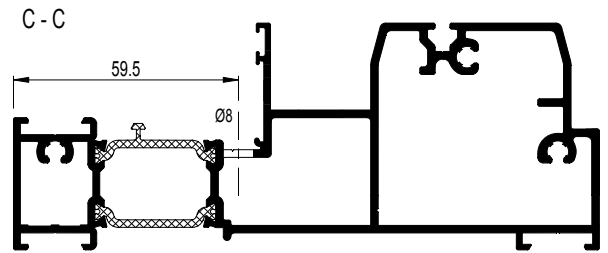
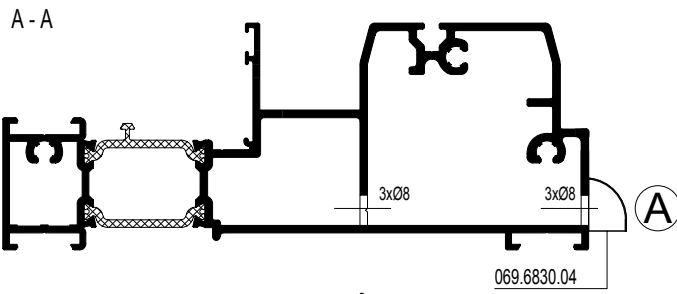

TYPE XQX

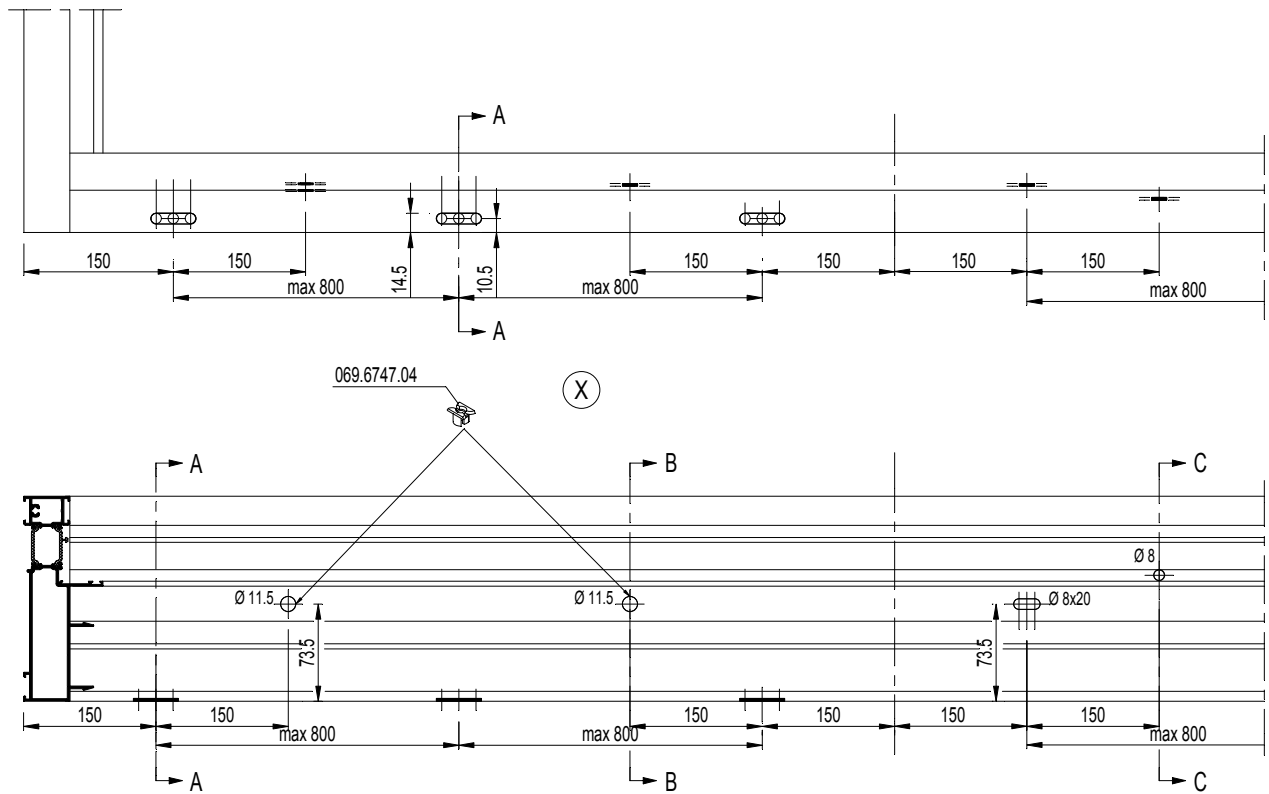

BOORMAL
 CALIBRE DE PERÇAGE
 BORING JIG
 BOHRLEHRE

097.0437.00

(A)

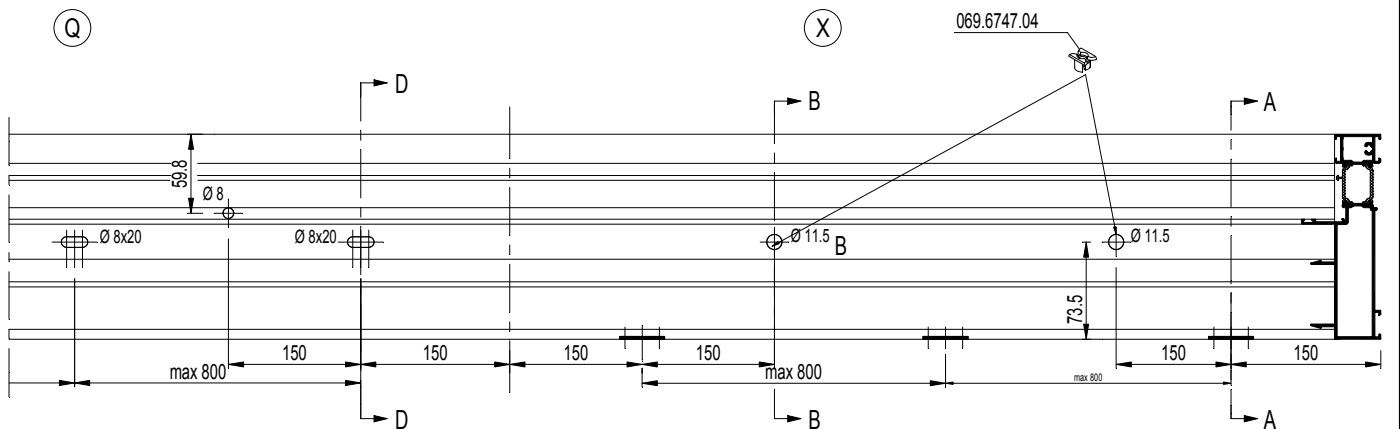
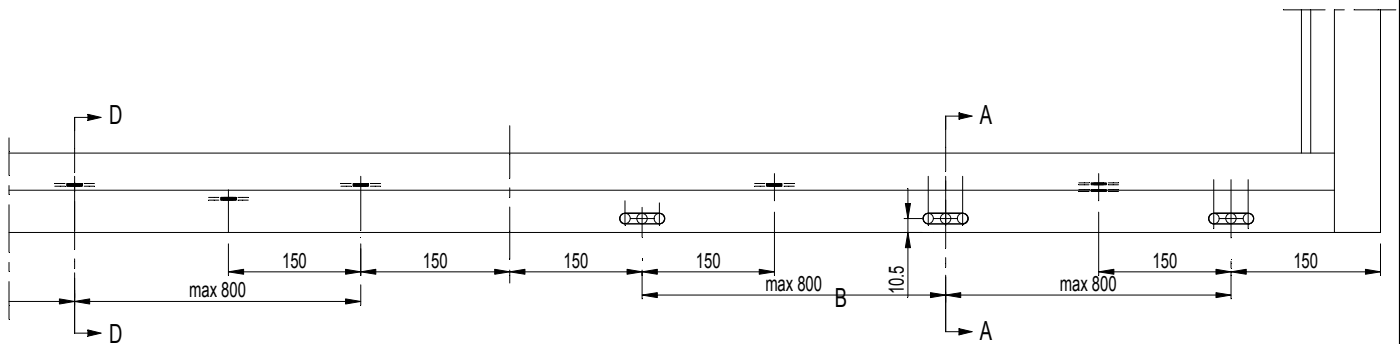
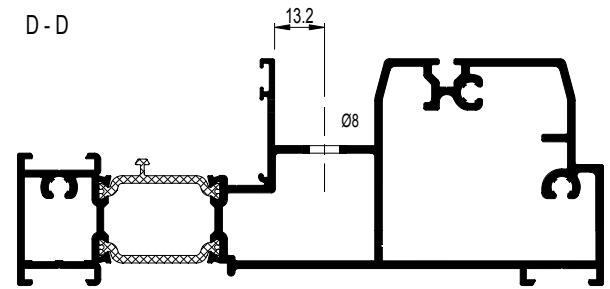
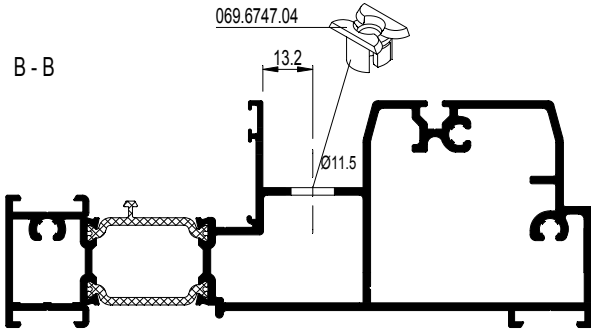
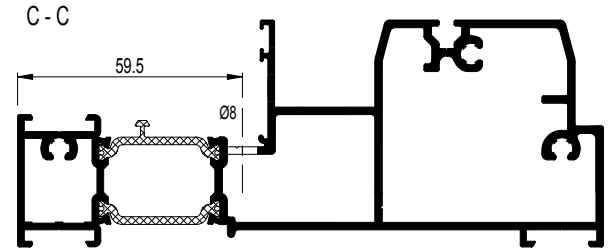
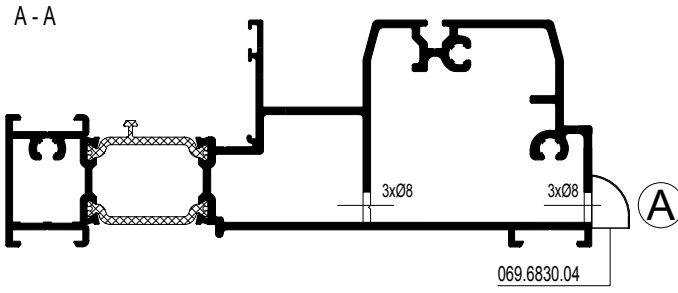

TYPE QXXQ

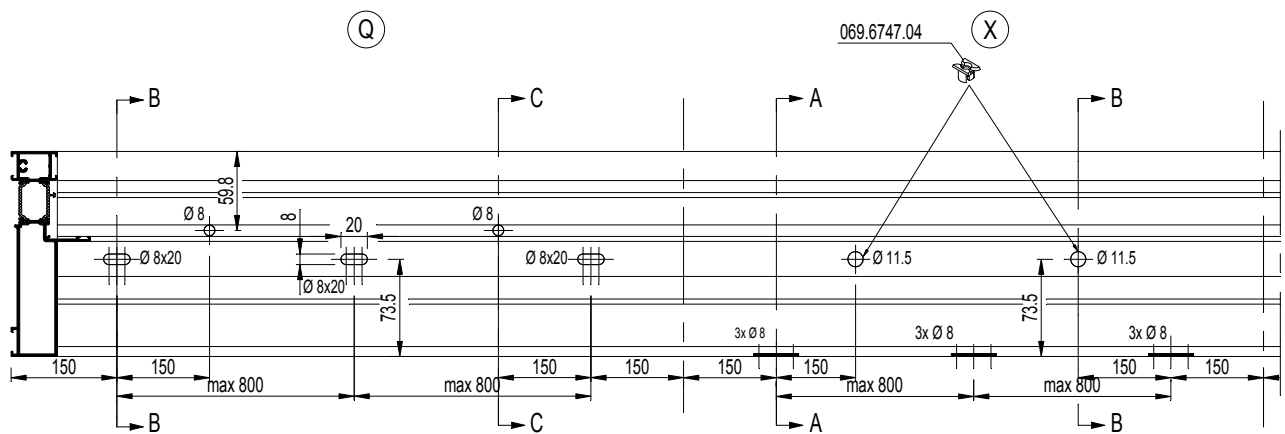
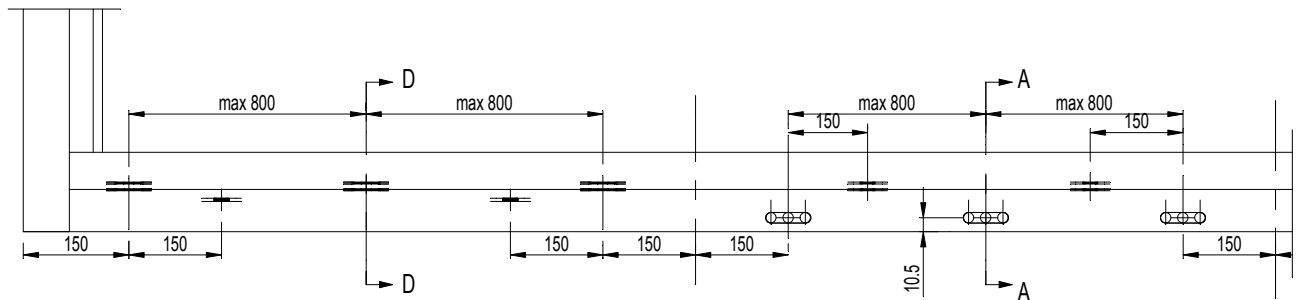

BOORMAL
 CALIBRE DE PERÇAGE
 BORING JIG
 BOHRLEHRE

097.0437.00

(A)

TYPE XXX
 TYPE XXQ

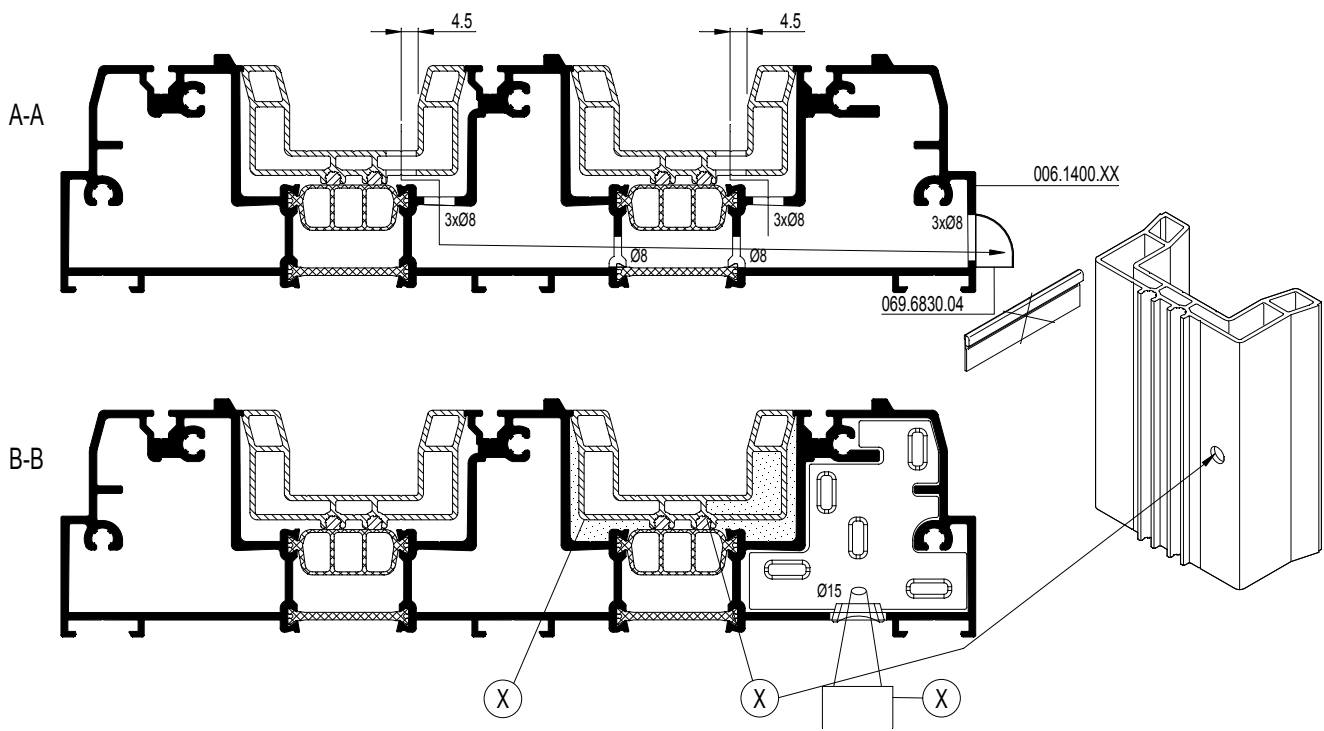
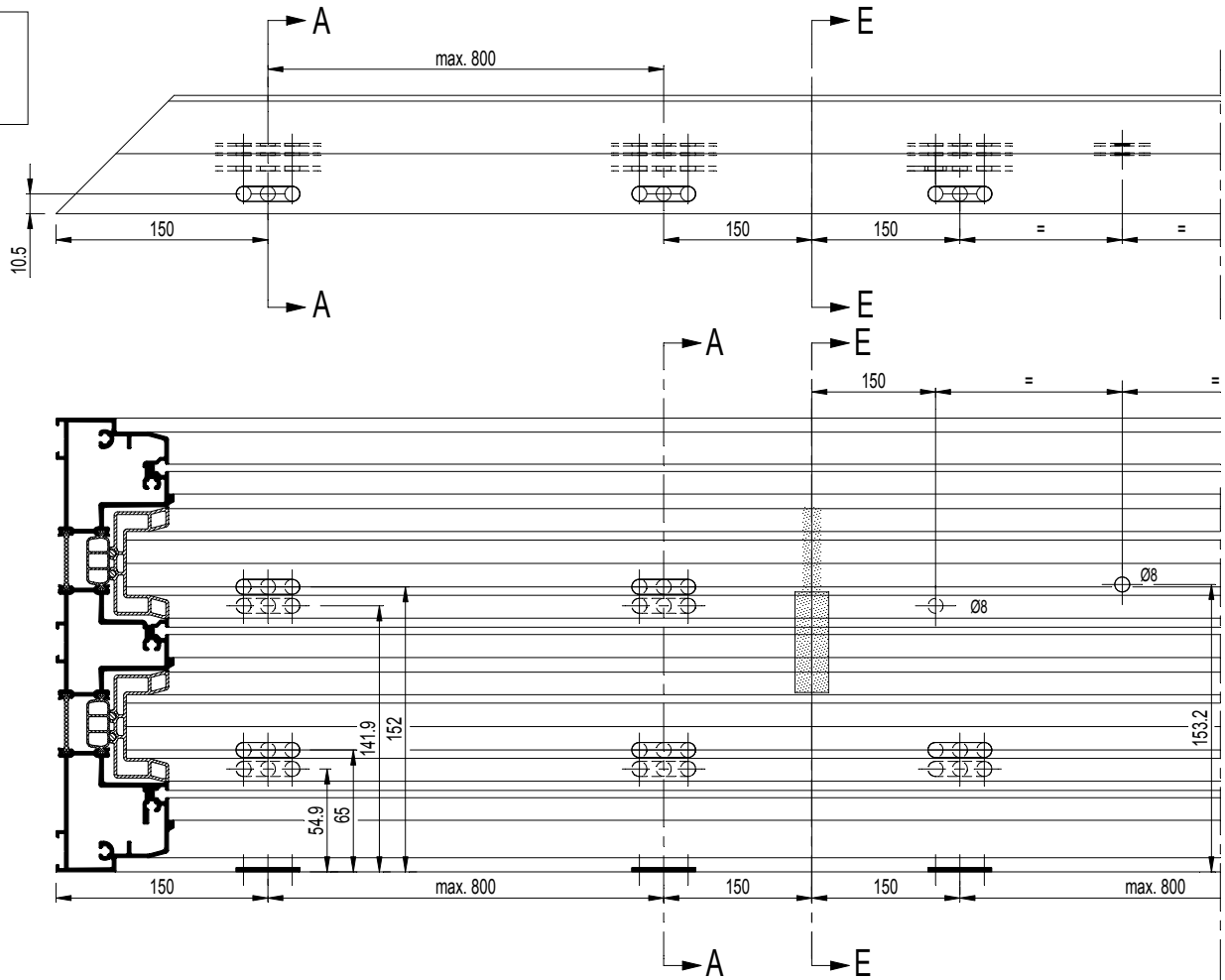

BOORMAL
 CALIBRE DE PERÇAGE
 BORING JIG
 BOHRLEHRE

097.0437.00 A-A

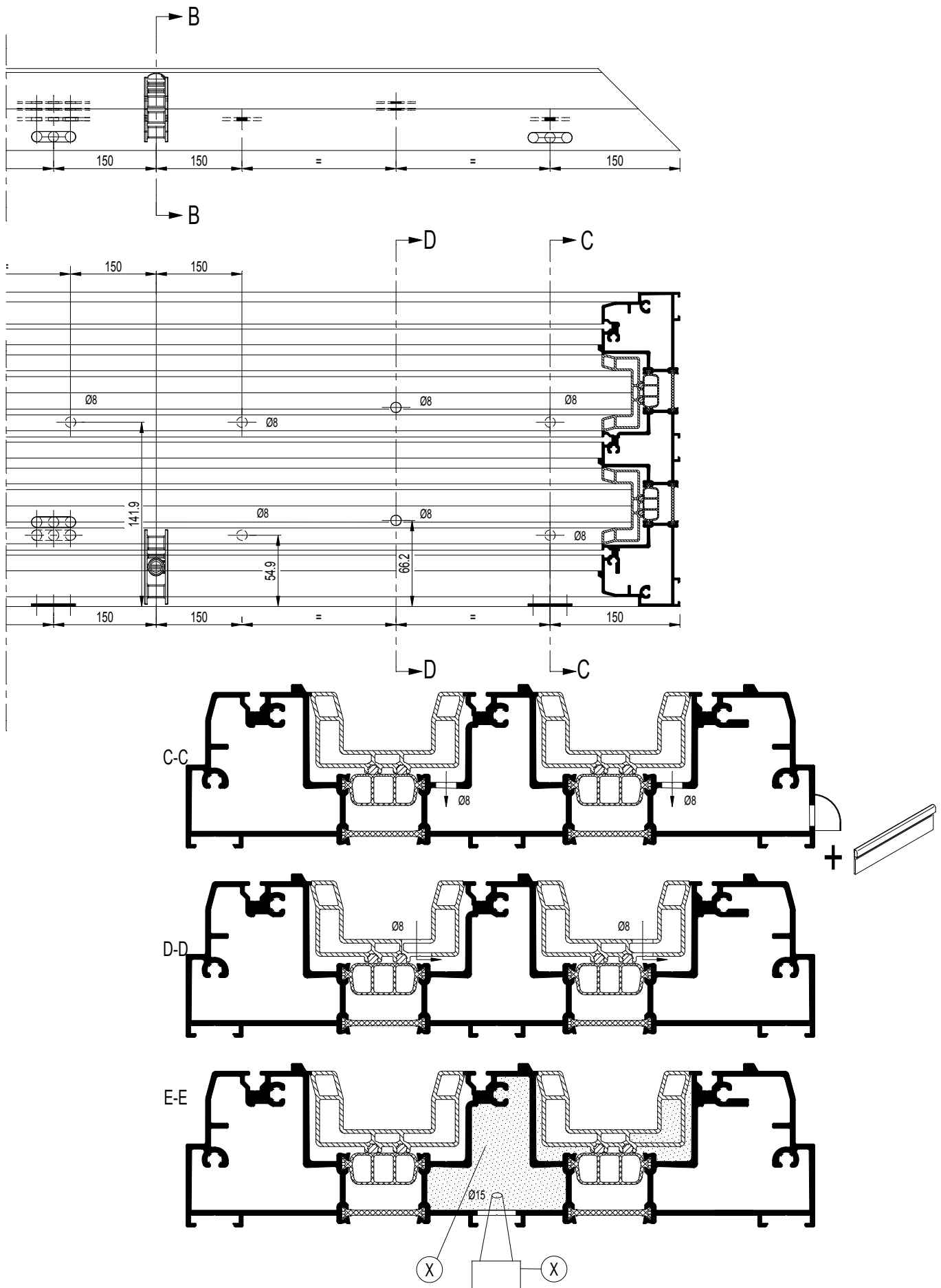

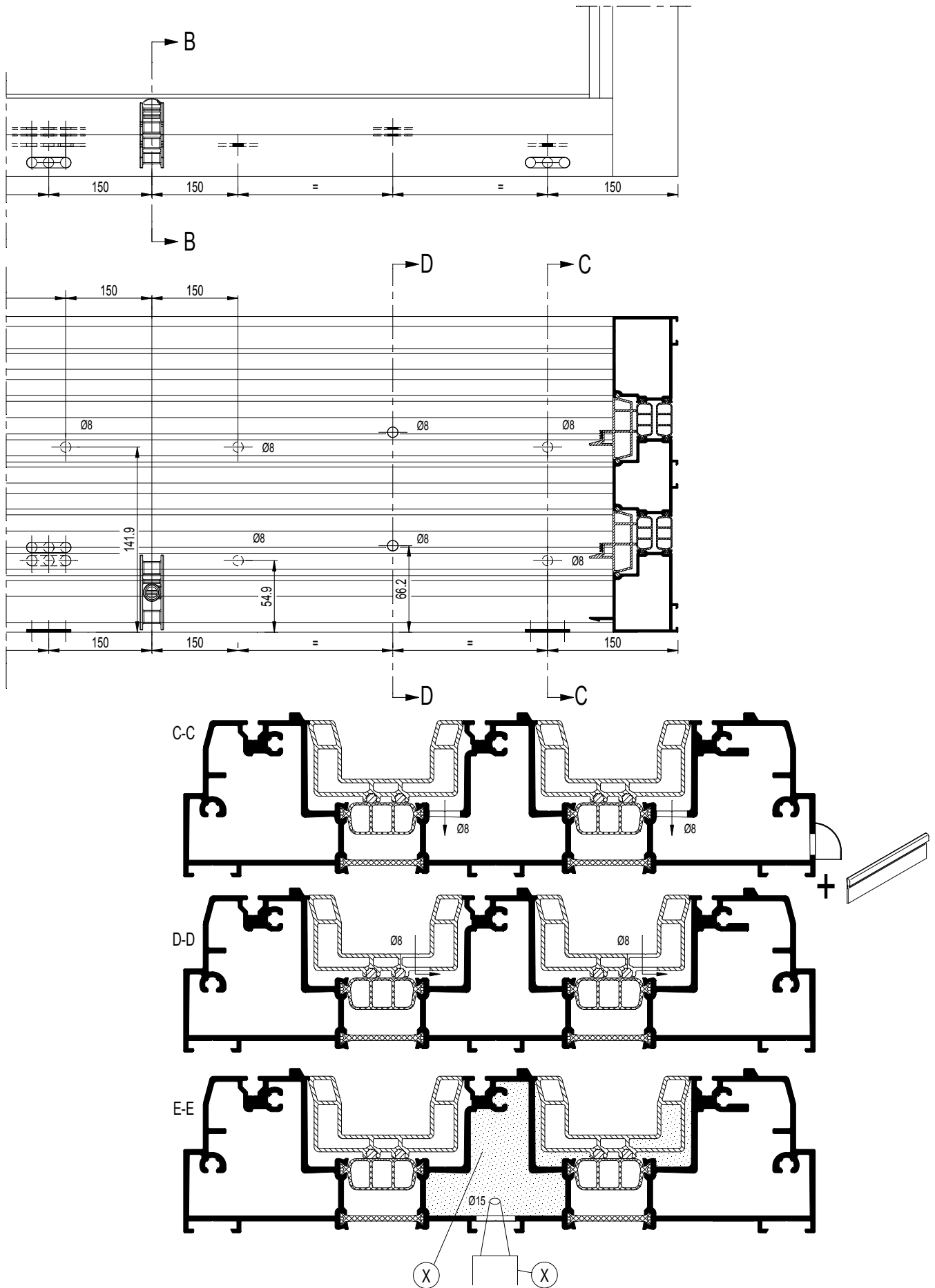

CP 155 CP 155-LS

KOPPELSTUK
PIECE DE RACCORDMENT
CONNECTION PIECE
KUPPLUNGSSTUECK

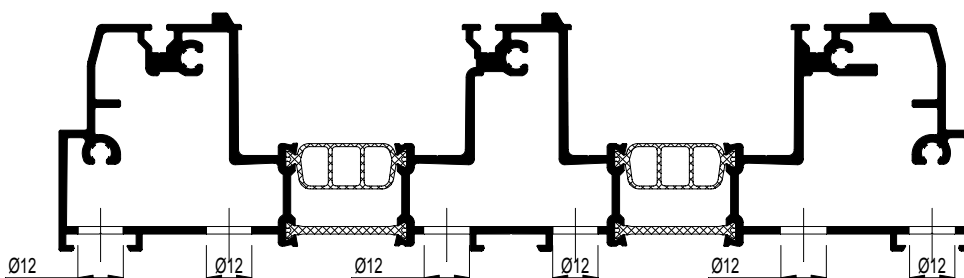
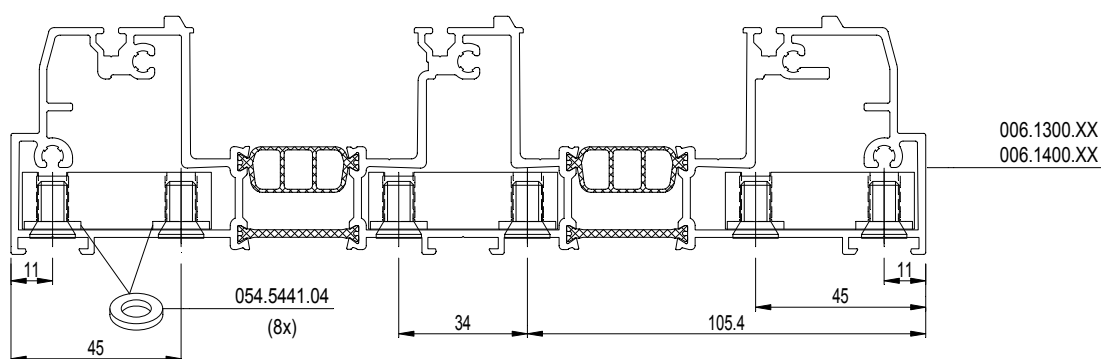
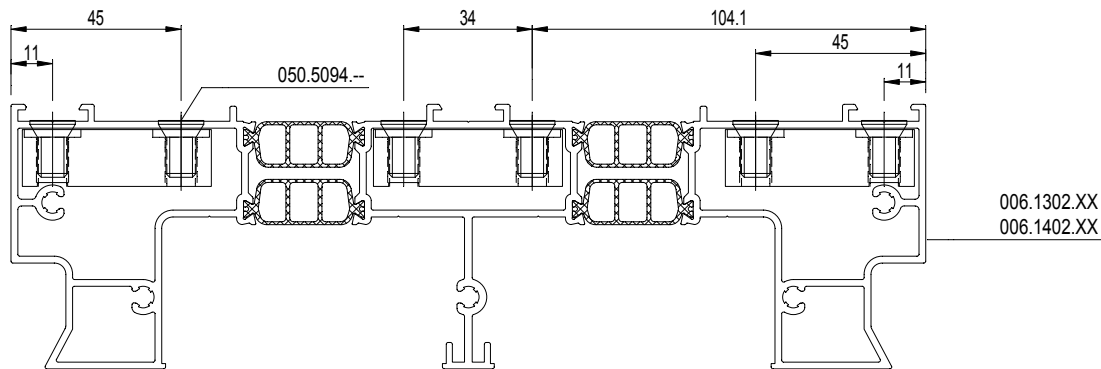

CP 155 CP 155-LS

KOPPELSTUK
PIECE DE RACCORDEMENT
CONNECTION PIECE
KUPPLUNGSSTUECK

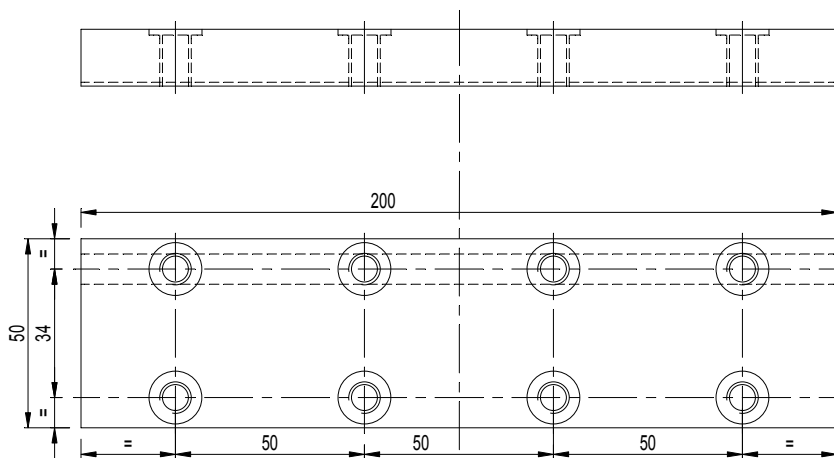
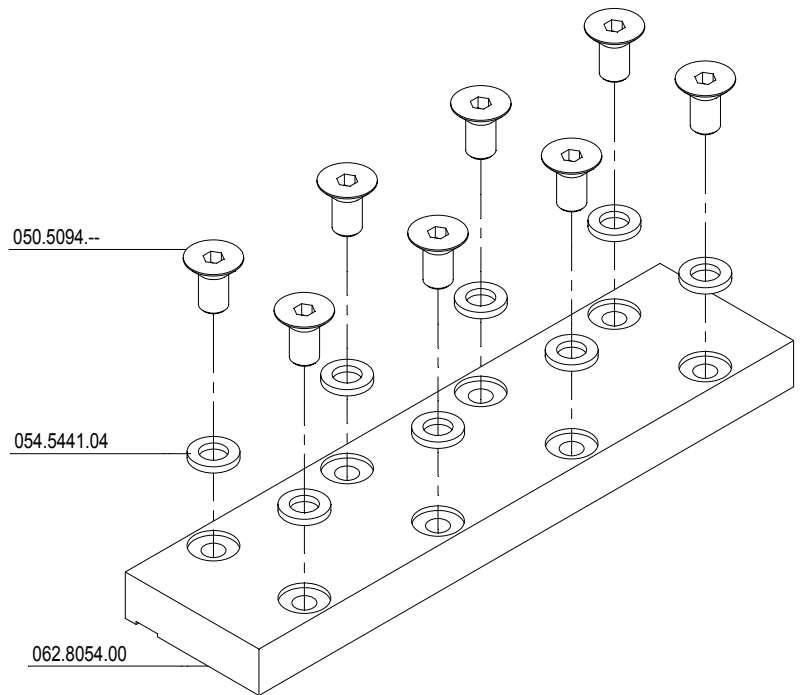
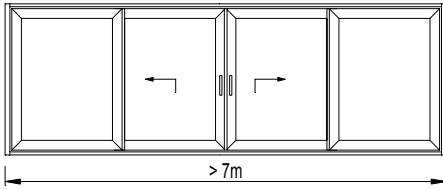

(X) DICHTINGSMIDDEL
MATIERE D'ETANCHEITE
SEALING AGENT
ABDICHTUNG

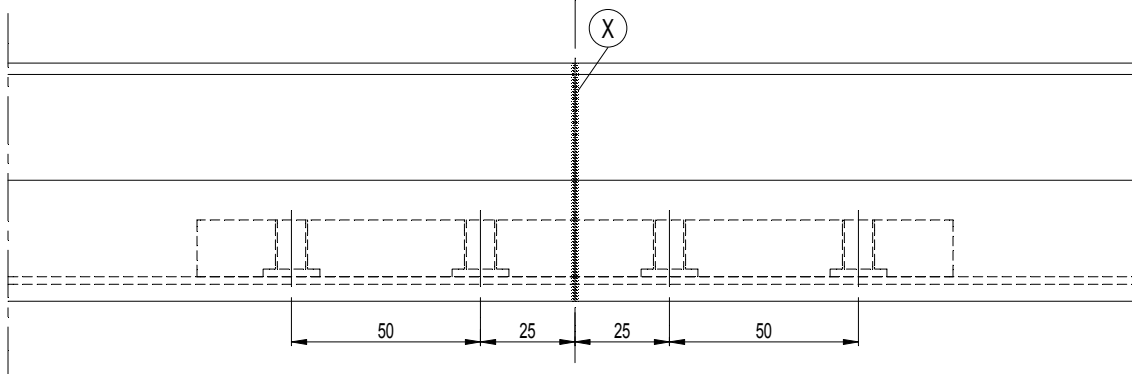

CP 155 CP 155-LS

GLASSTEUNEN
SUPPORTS CALE DE VITRAGE
GLASS SUPPORTS
KLOTZBRUECKEN

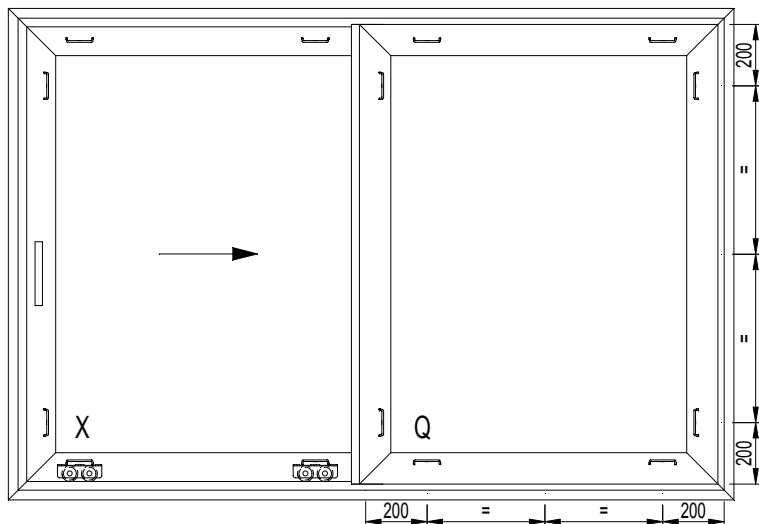
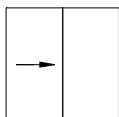

Glassteun:(0-250kg/vleugel) 8x069.8722.04
Supports de cale de vitrage:(0-250kg/ouvrant) 8x069.8722.04
Glasauflageprofil:(0-250kg/Fluegel) 8x069.8722.04
Glass support:(0-250kg/vent) 8x069.8722.04

Loopwagen:
Roulettes: 0-250kg: 2x062.7834.-- + 4x052.5372.--
Rollers:
Laufwagen:

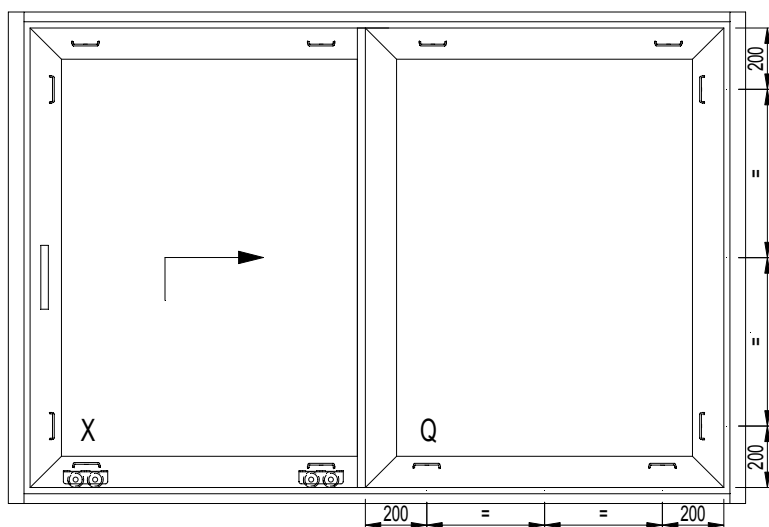
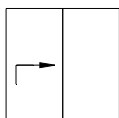

Glassteun:(0-250kg/vleugel) 8x069.8722.04
(250-400kg/vleugel) 6x069.8722.04 + 2x069.8724.04
Supports de cale de vitrage:(0-250kg/ouvrant) 8x069.8722.04
(250-400kg/ouvrant) 6x069.8722.04 + 2x069.8724.04
Glass support:(0-250kg/vent) 8x069.8722.04
(250-400kg/vent) 6x069.8722.04 + 2x069.8724.04
Glasauflageprofil:(0-250kg/Fluegel) 8x069.8722.04
(250-400kg/Fluegel) 6x069.8722.04 + 2x069.8724.04

Loopwagen:
Roulettes: 0-300kg:1x062.7867.--
Rollers: 300-400kg:1x062.7867.-- + 1x062.7903.--
Laufwagen:

CP 155 CP 155-LS

MONTAGE KLEMSTUK
ASSEMBLAGE PIECE DE BLOCAGE
ASSEMBLY FIXING PIECE
MONTAGE BEFESTIGUNGSKLOTZ

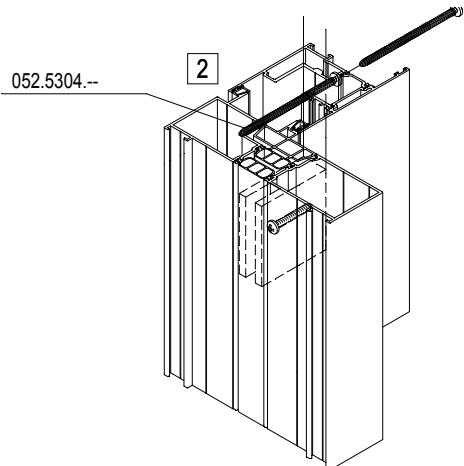
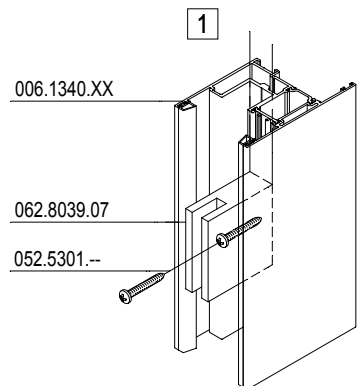
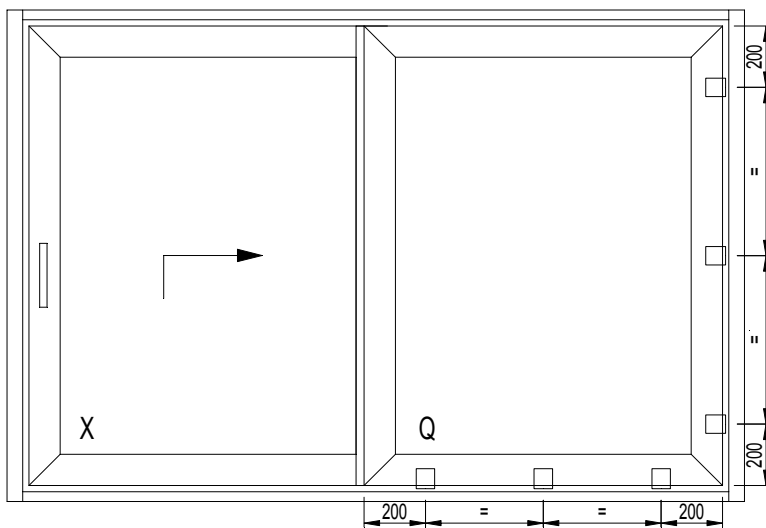
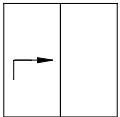
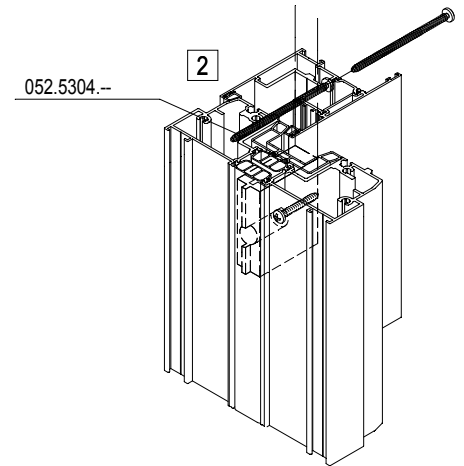
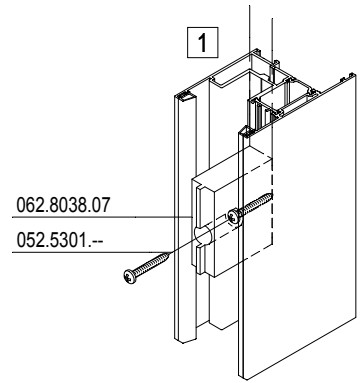
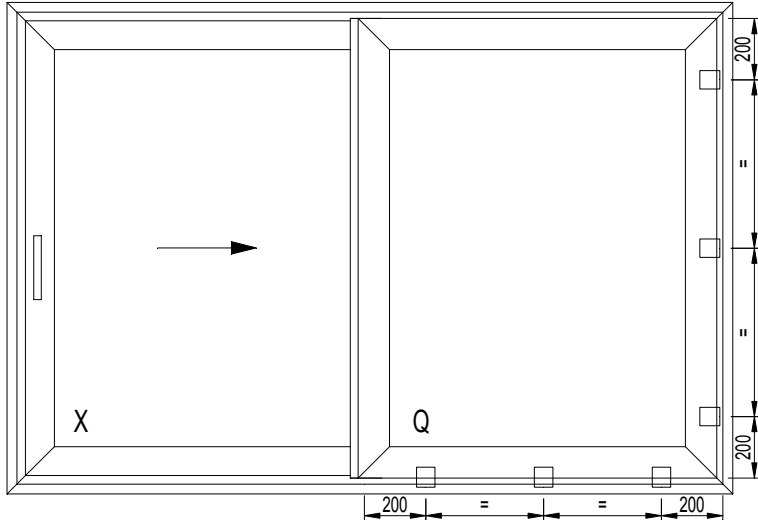
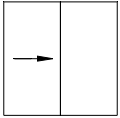

MONTAGEVOLGORDE
L'ORDRE DE MONTAGE
THE ORDER OF ASSEMBLY
MONTAGEREIHENFOLGE

- | | | | |
|---|---|---|---|
| 1 | 2 | 3 | . |
|---|---|---|---|

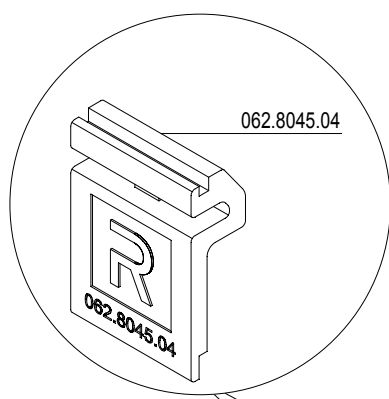
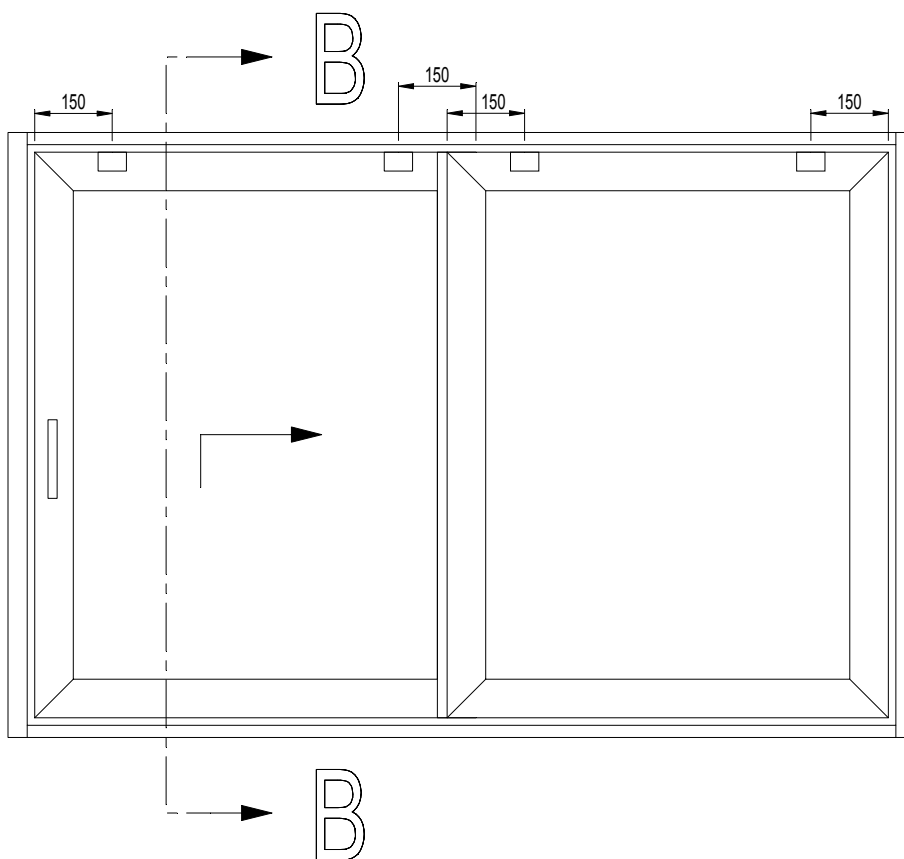
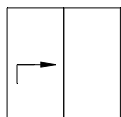

B - B

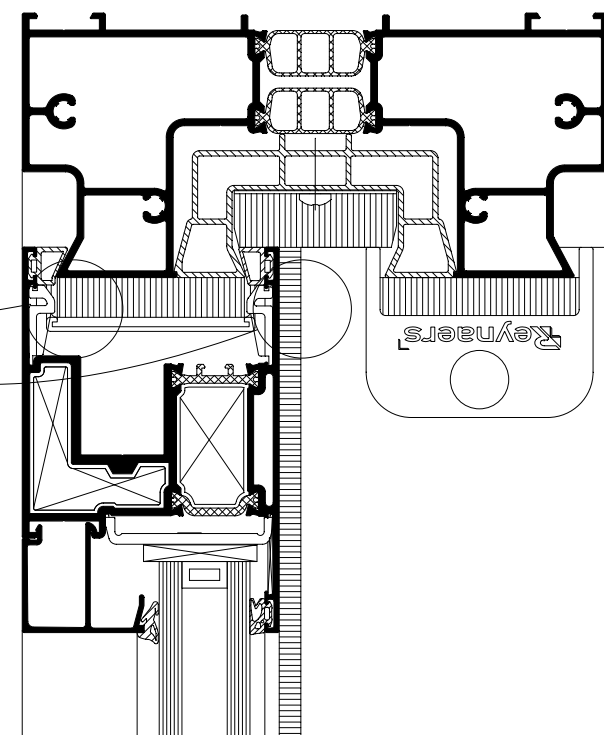

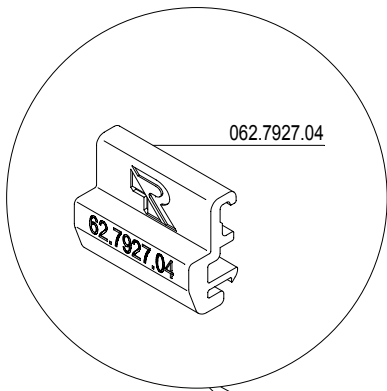
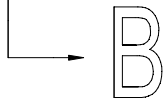
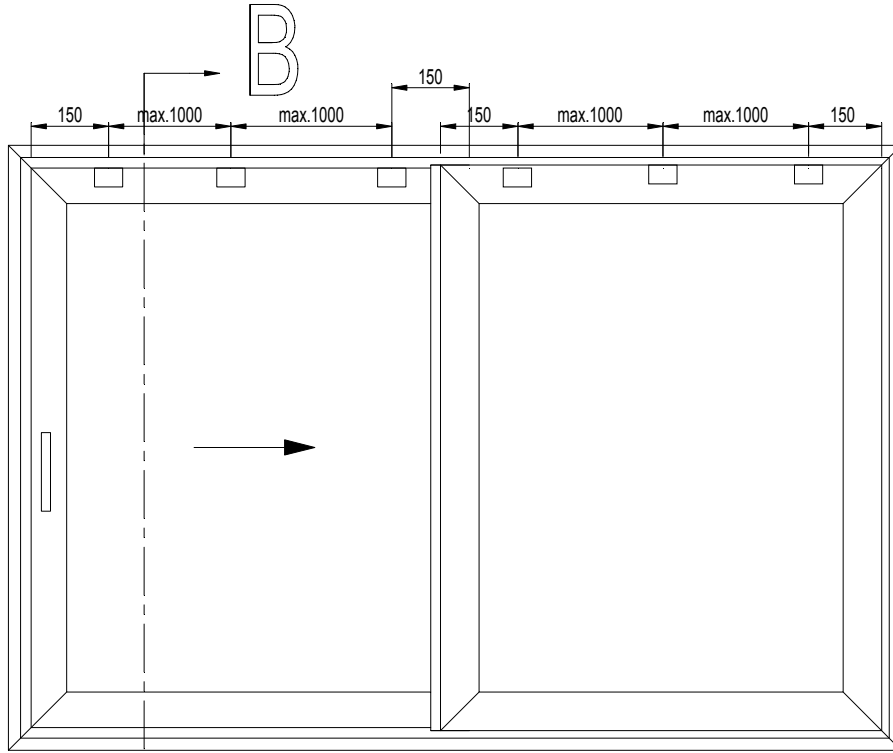
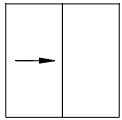

B - B

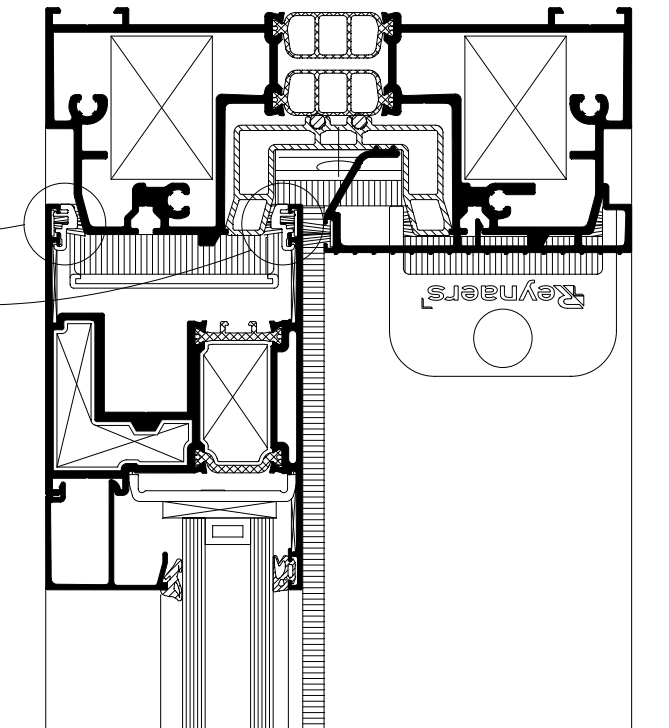

CP 155 CP 155-LS

MAX. TOELAATBARE AFMETINGEN VLEUGELS
 DIMENSIONS MAX. ADMISSIBLE OUVRANTS
 MAX. ADMISSIBLE SIZES VENTS
 MAX. ZULAESSIGE ABMESSUNGEN FLUEGELS

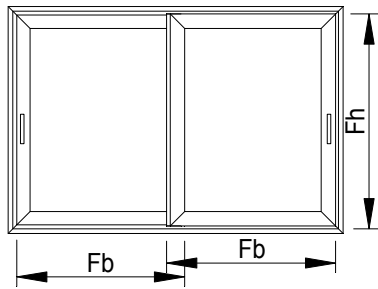

①

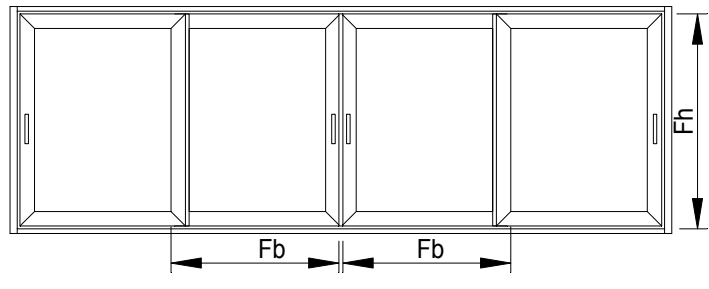

②

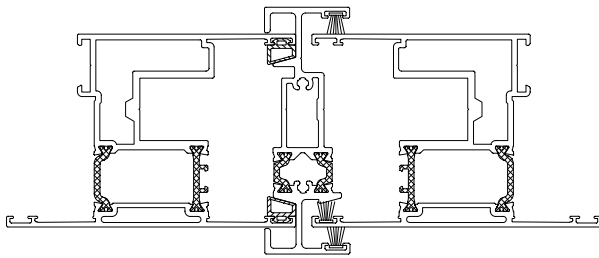

ly = 110,00cm?

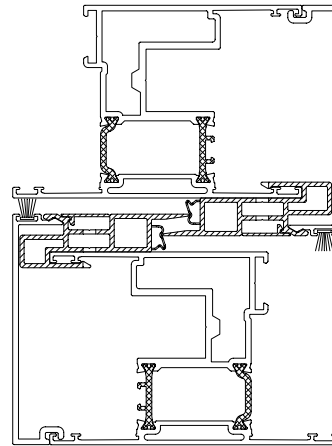

ly = 117,04cm?

③

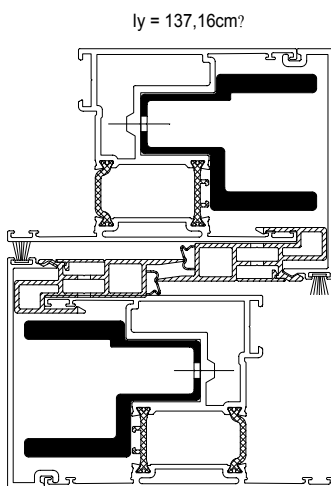

ly = 137,16cm?

④

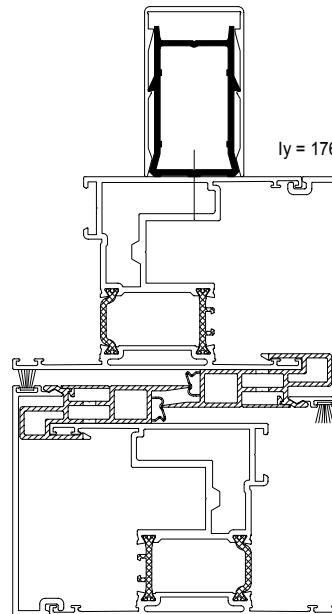

ly = 176,90cm?

VERSTERKINGSPROFIEL 006.1343.00
 PROFILE DE RENFORCEMENT 006.1343.00
 REINFORCEMENT PROFILE 006.1343.00
 VERSTAERKUNGSPROFIL 006.1343.00

VERSTERKINGSPROFIEL 030.1097.00
 PROFILE DE RENFORCEMENT 030.1097.00
 REINFORCEMENT PROFILE 030.1097.00
 VERSTAERKUNGSPROFIL 030.1097.00

CP 155 CP 155-LS

MAX. TOELAATBARE AFMETINGEN VLEUGELS
 DIMENSIONS MAX. ADMISSIBLE OUVRANTS
 MAX. ADMISSIBLE SIZES VENTS
 MAX. ZULAESSIGE ABMESSUNGEN FLUEGELS

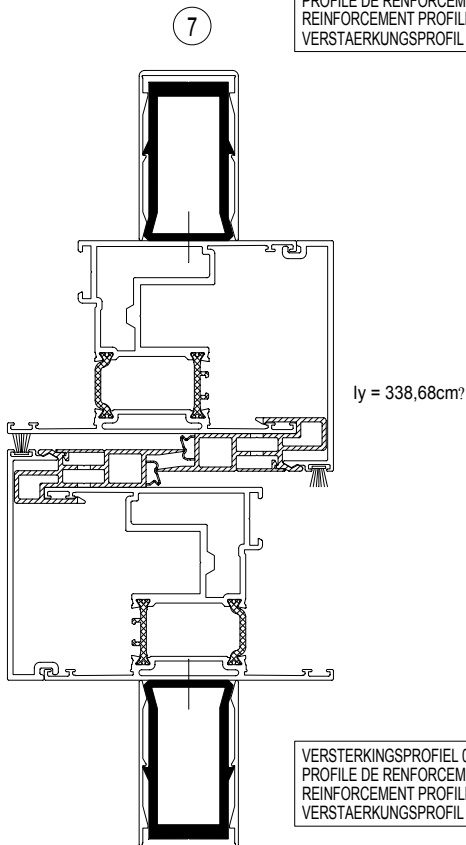
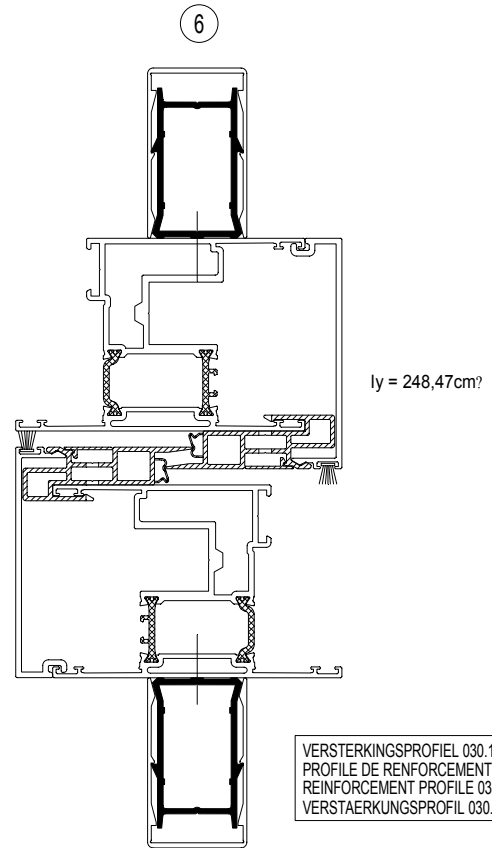
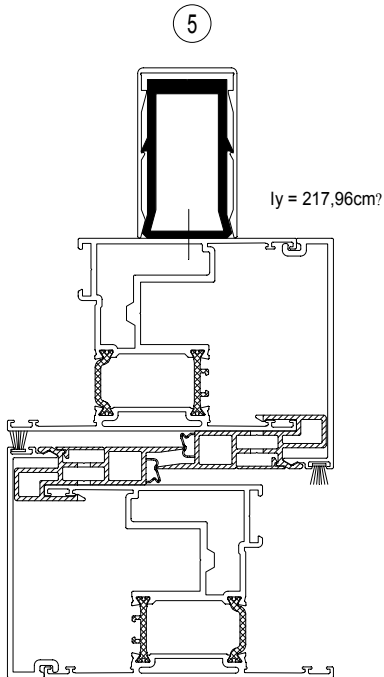

VERSTERKINGSPROFIEL 030.1098.00
 PROFILE DE RENFORCEMENT 030.1098.00
 REINFORCEMENT PROFILE 030.1098.00
 VERSTAERKUNGSPROFIL 030.1098.00

VERSTERKINGSPROFIEL 030.1097.00
 PROFILE DE RENFORCEMENT 030.1097.00
 REINFORCEMENT PROFILE 030.1097.00
 VERSTAERKUNGSPROFIL 030.1097.00

VERSTERKINGSPROFIEL 030.1098.00
 PROFILE DE RENFORCEMENT 030.1098.00
 REINFORCEMENT PROFILE 030.1098.00
 VERSTAERKUNGSPROFIL 030.1098.00

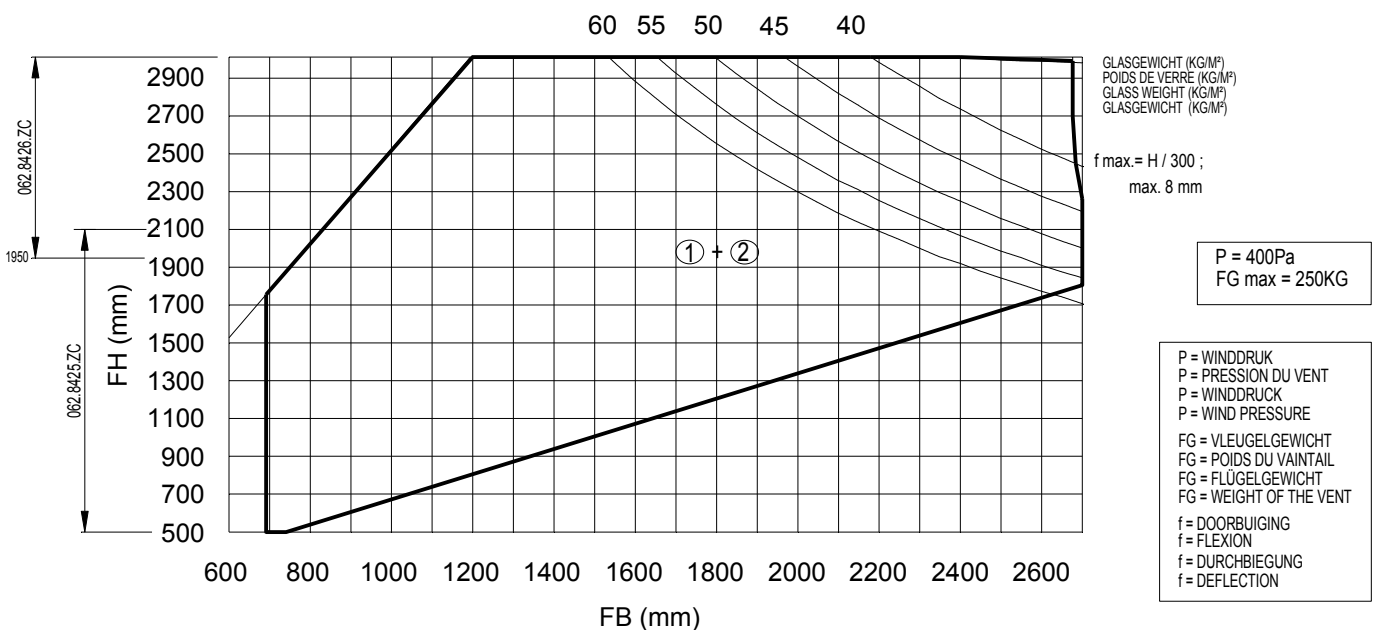
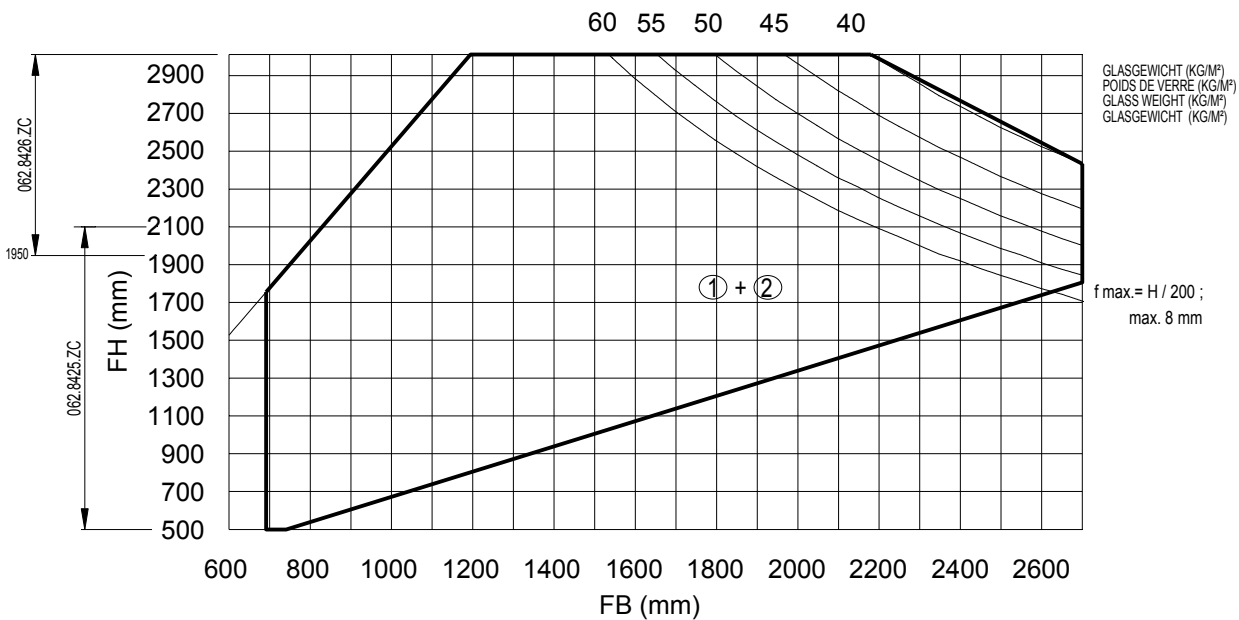
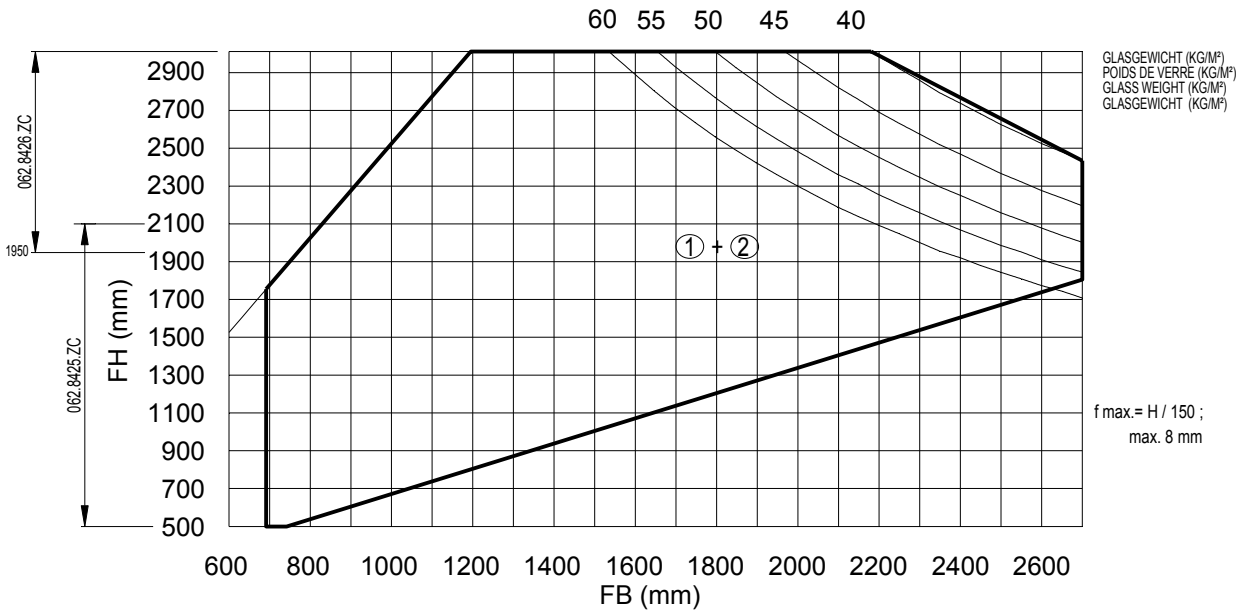

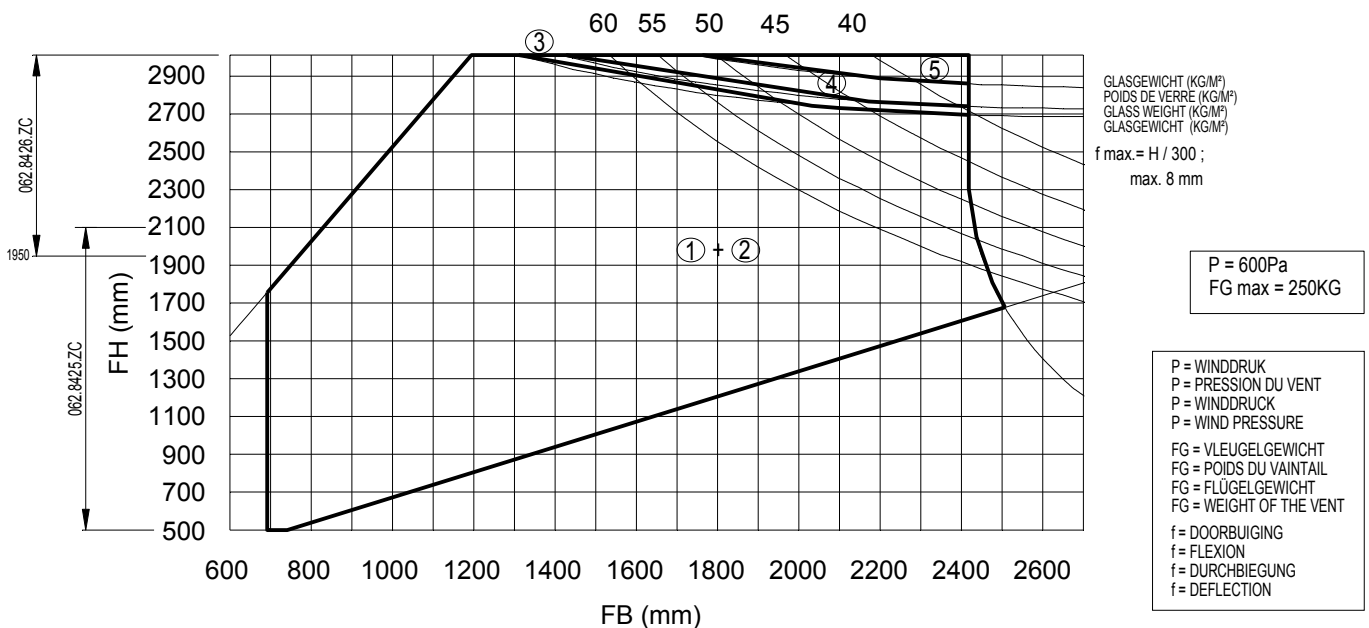
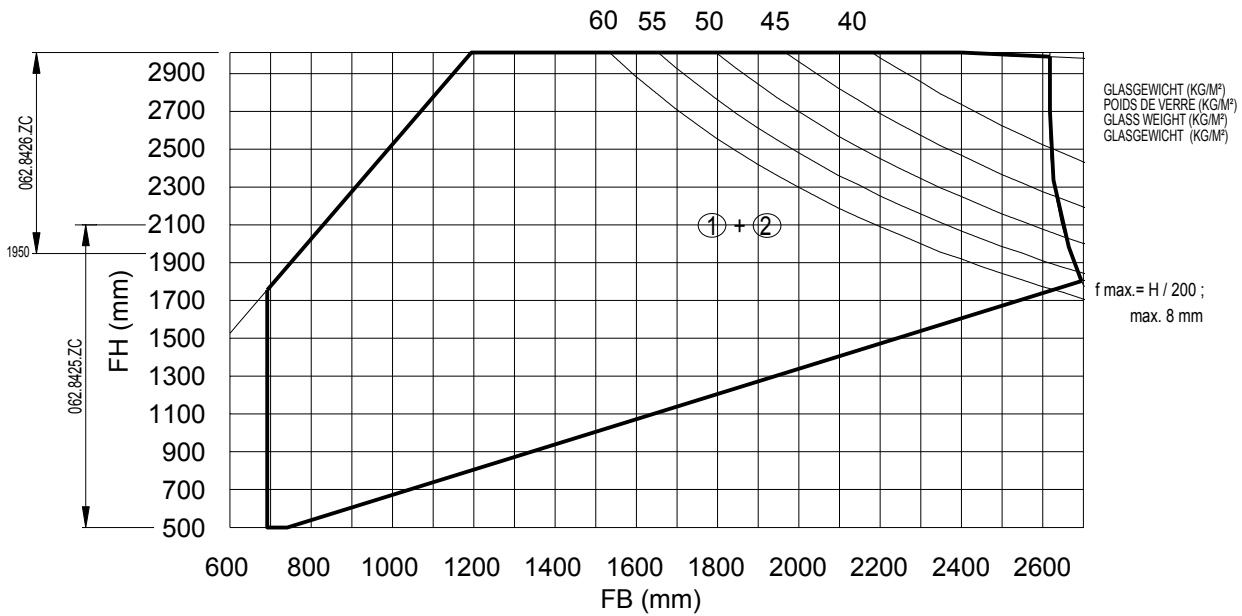
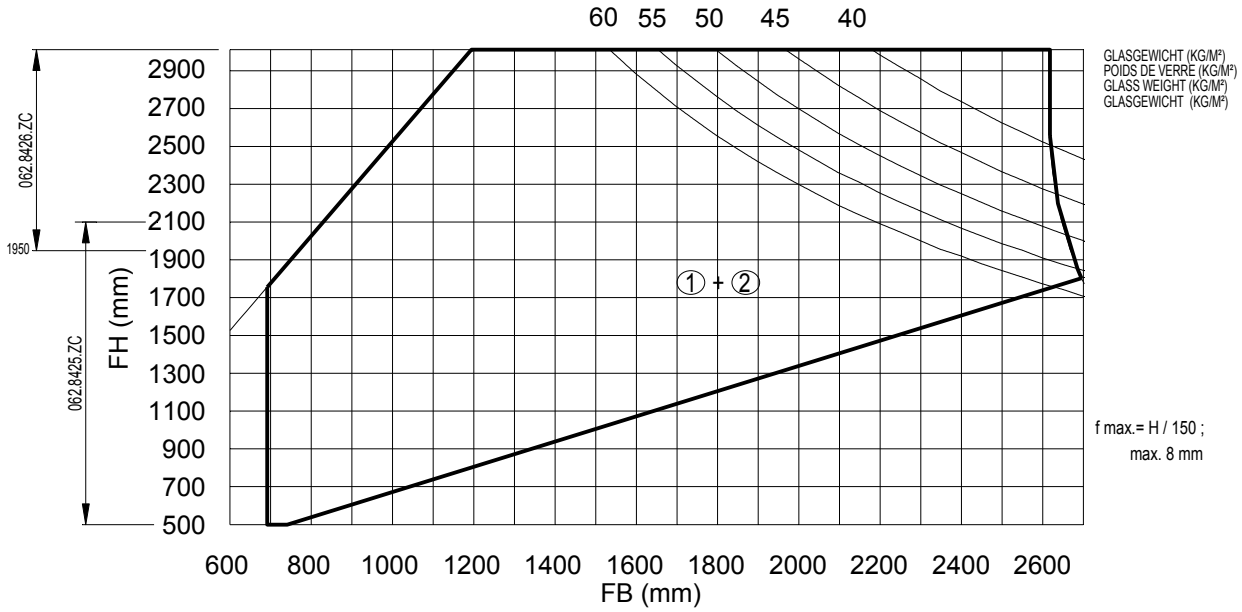

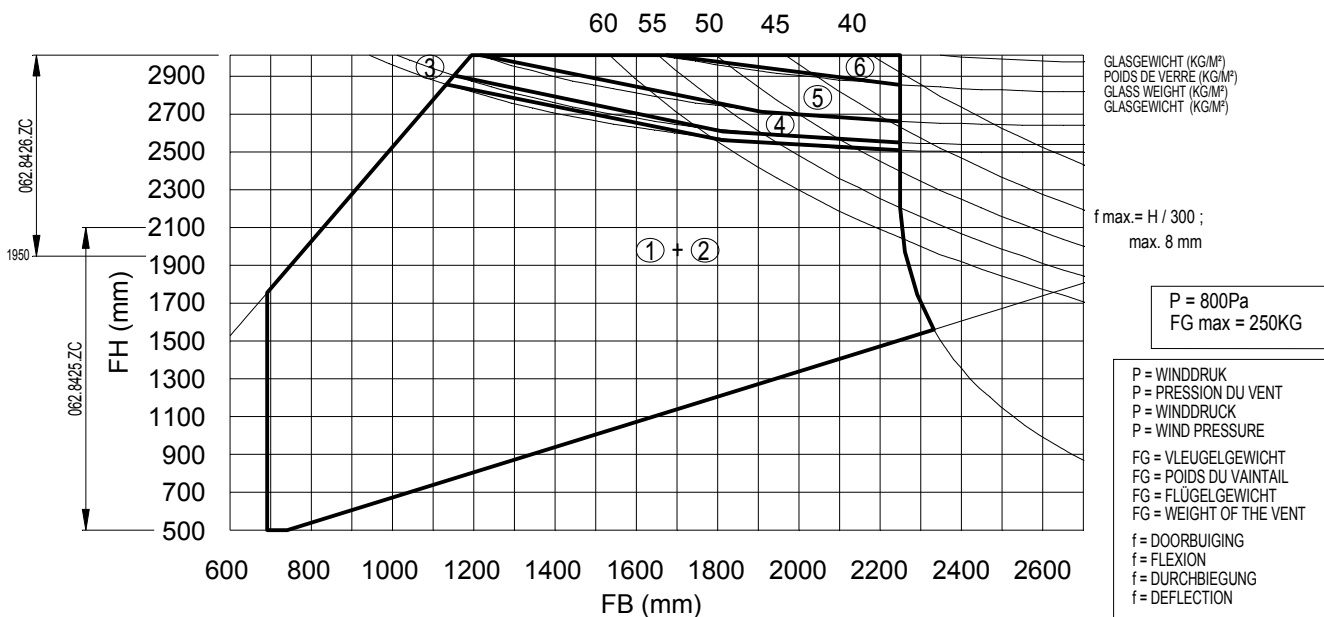
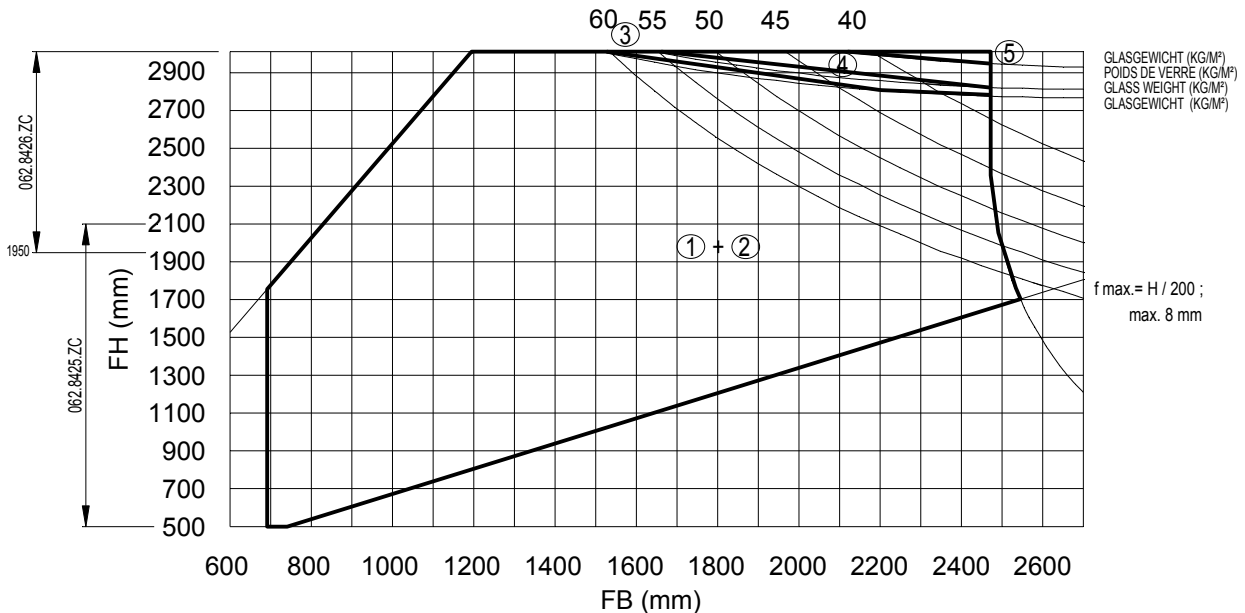
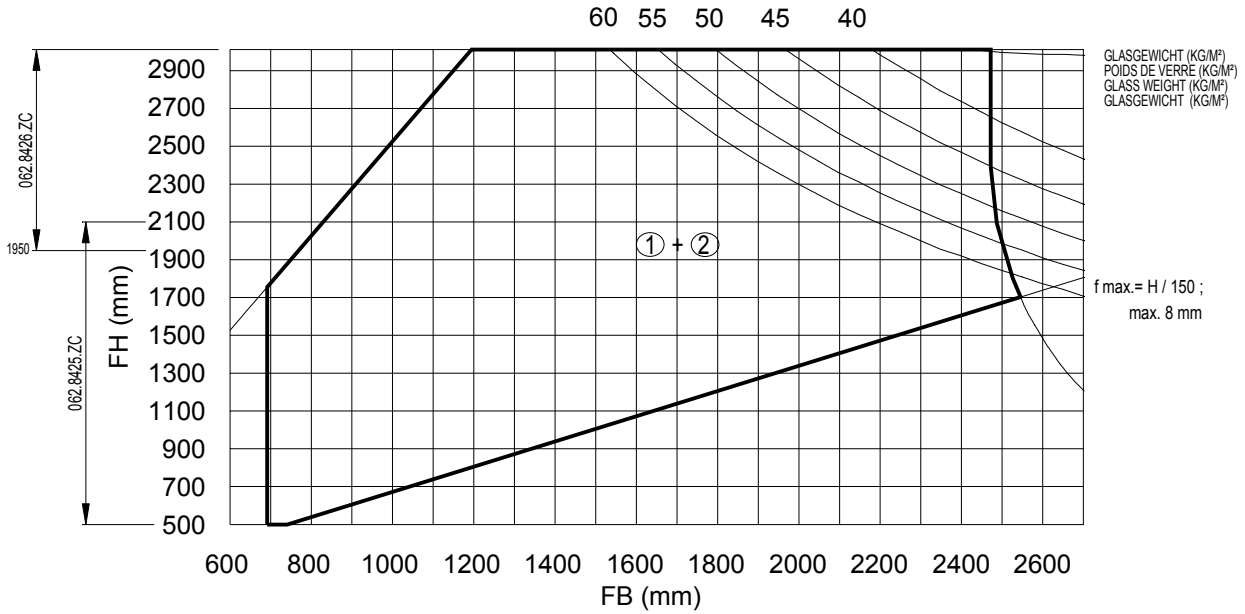

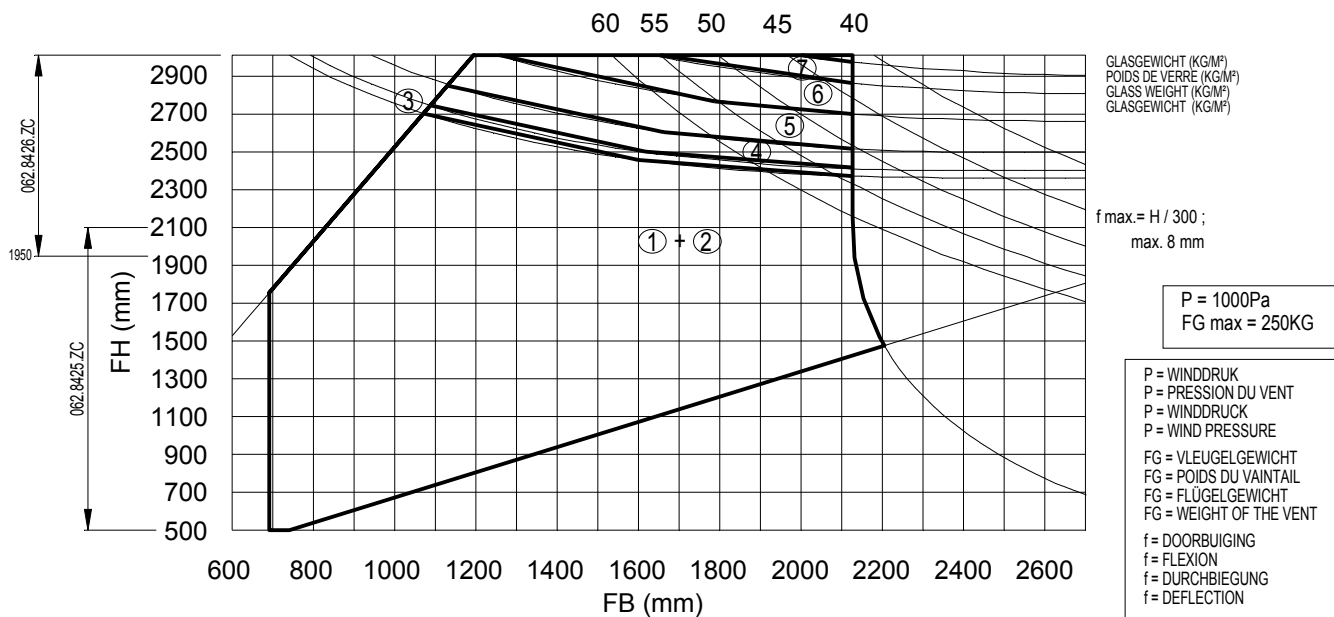
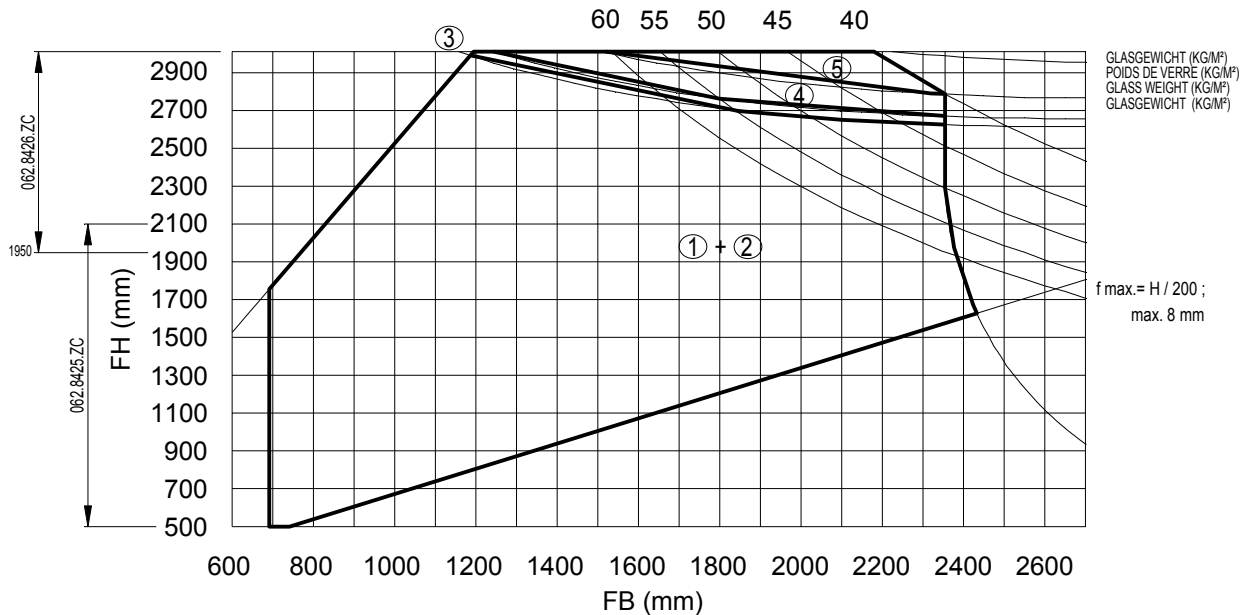
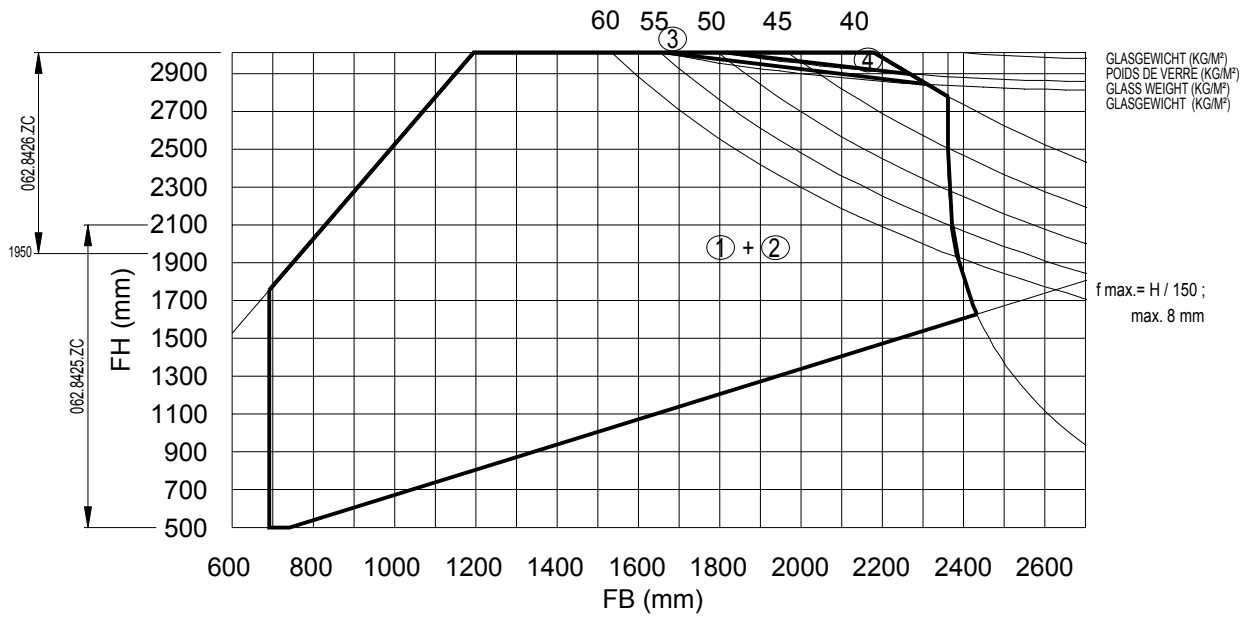

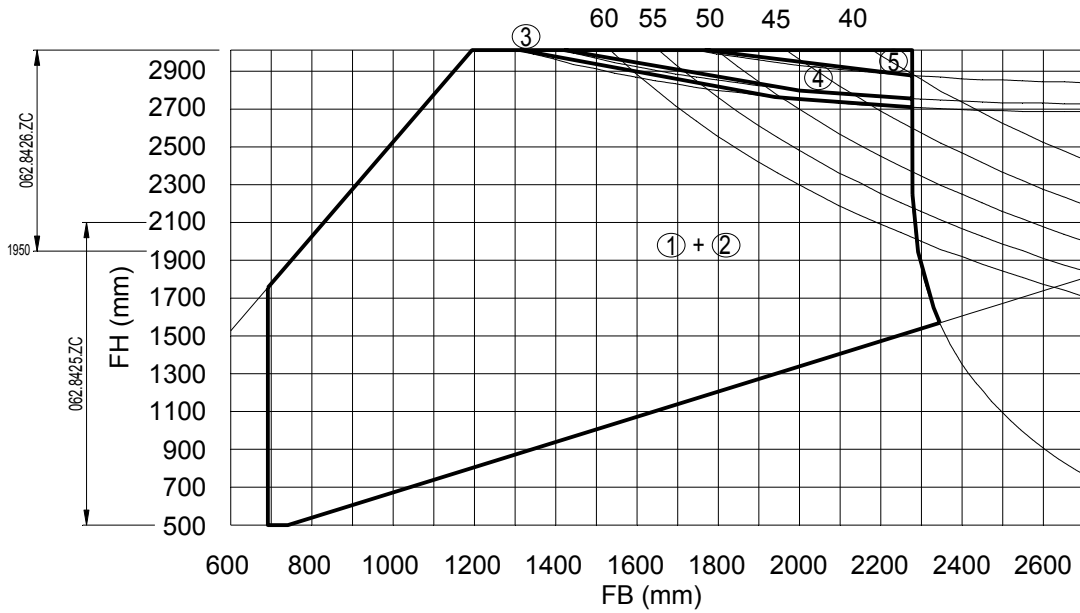

GLASGEWICHT (KG/M²)
 POIDS DE VERRE (KG/M²)
 GLASS WEIGHT (KG/M²)
 GLASGEWICHT (KG/M²)

$f_{max} = H / 150$;
 max. 8 mm

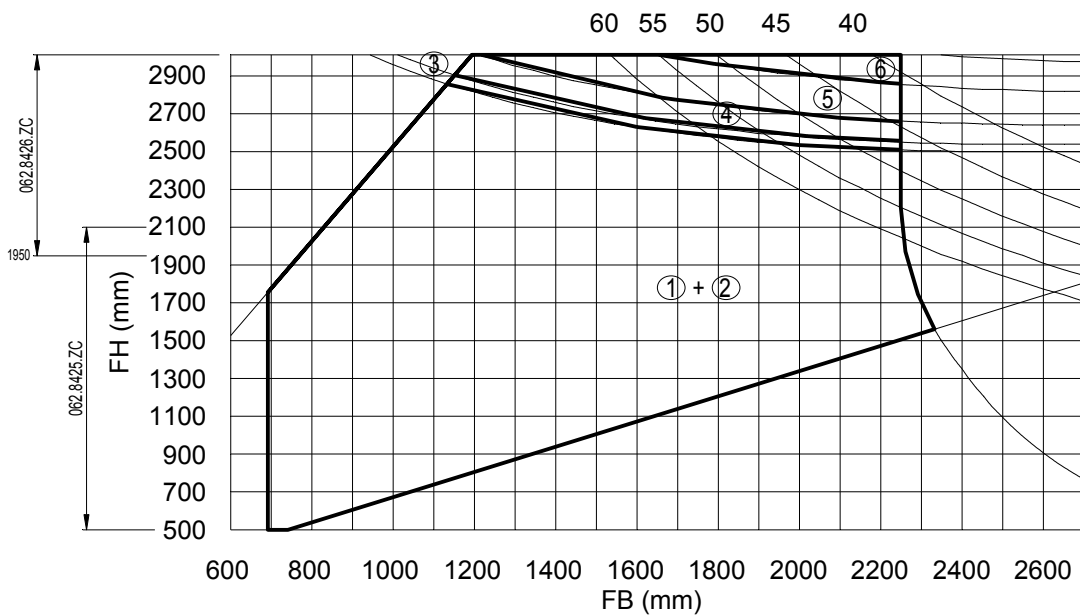

GLASGEWICHT (KG/M²)
 POIDS DE VERRE (KG/M²)
 GLASS WEIGHT (KG/M²)
 GLASGEWICHT (KG/M²)

$f_{max} = H / 200$;
 max. 8 mm

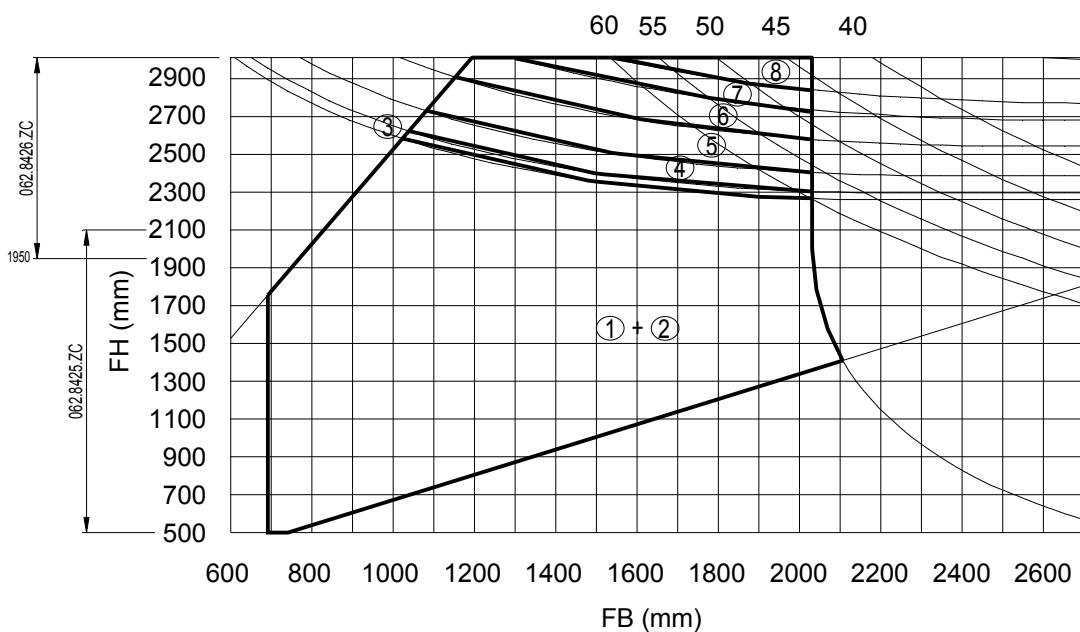

GLASGEWICHT (KG/M²)
 POIDS DE VERRE (KG/M²)
 GLASS WEIGHT (KG/M²)
 GLASGEWICHT (KG/M²)

$f_{max} = H / 300$;
 max. 8 mm

P = 1200Pa
FG max = 300KG

P = WINDDRUK
 P = PRESSION DU VENT
 P = WINDDRUCK
 P = WIND PRESSURE
 FG = VLEUGELGEWICHT
 FG = POIDS DU VAINTAIL
 FG = FLÜGELGEWICHT
 FG = WEIGHT OF THE VENT
 f = DOORBUIGING
 f = FLEXION
 f = DURCHBIEGUNG
 f = DEFLECTION

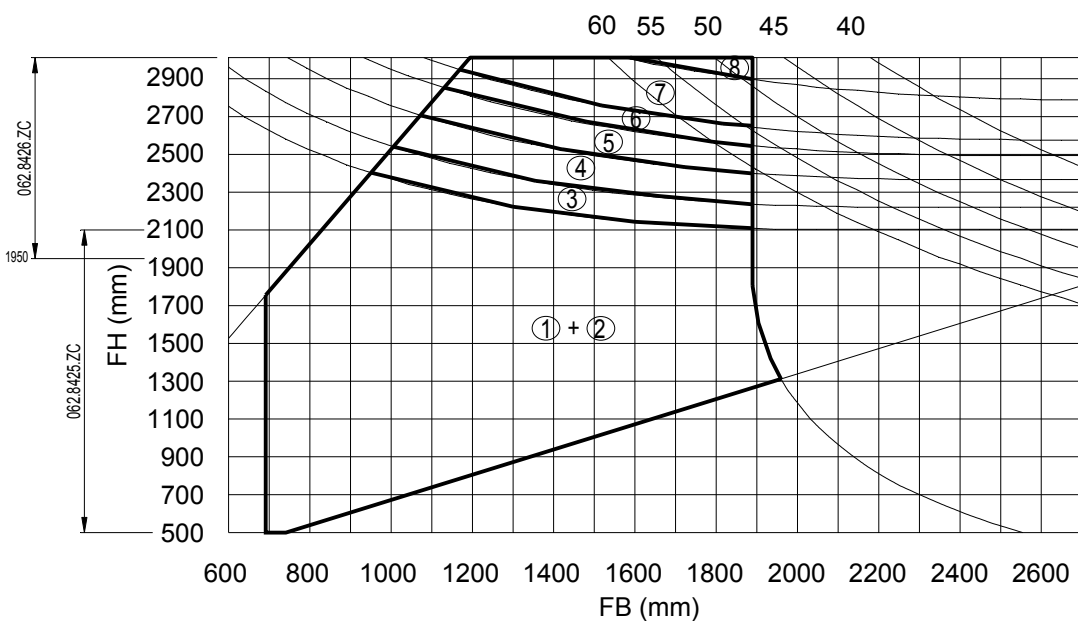
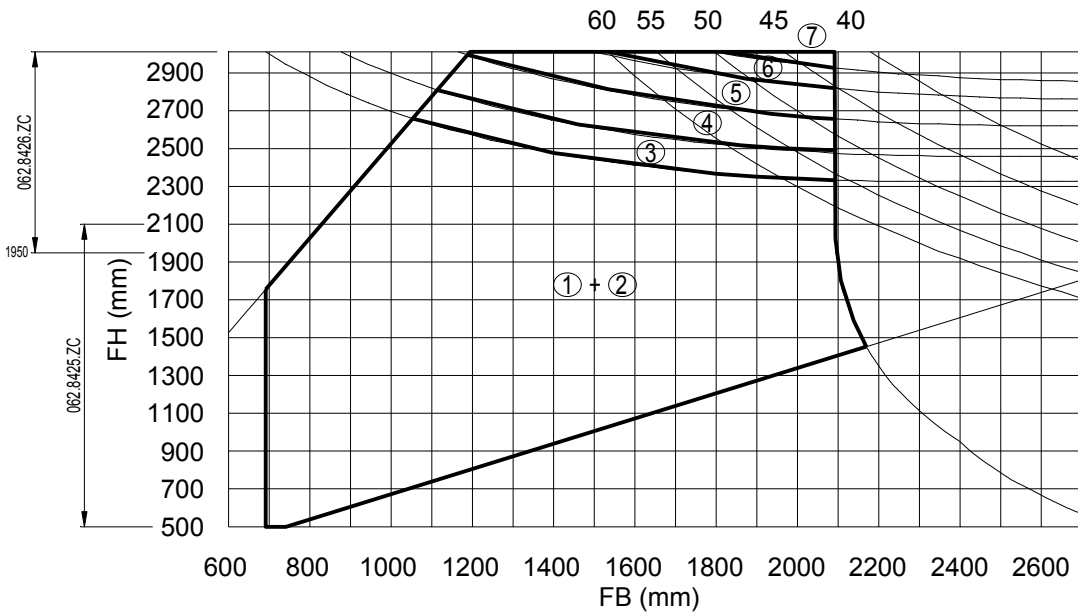
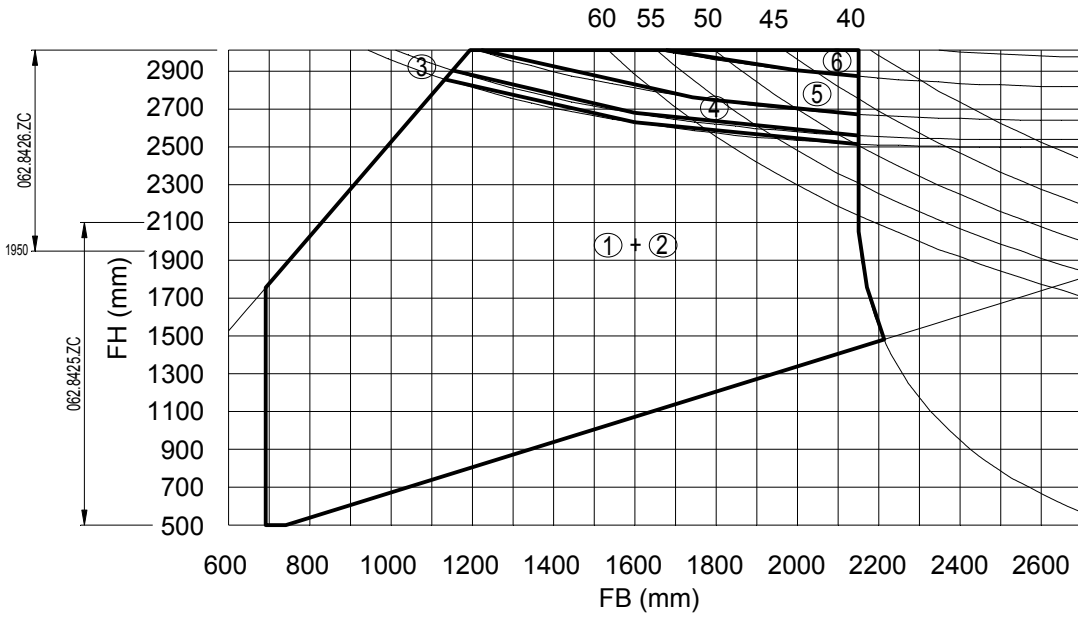

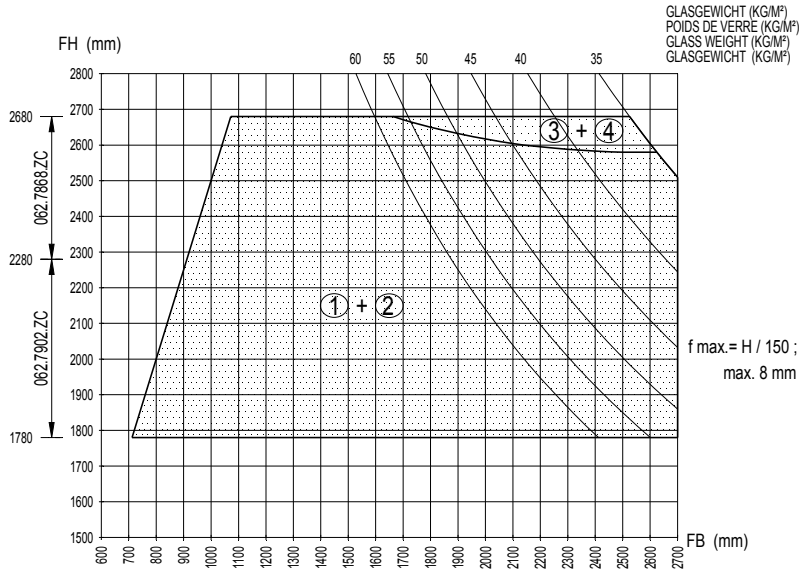

P = 600Pa
 FG max = 300KG
 FG max = 400KG*

* = ZIE BLZ 34.E. ...
 * = VOIR PAGES 34.E. ...
 * = SEE PAGES 34.E. ...
 * = SIEHE SEITEN 34.E. ...
 * FB MIN = 1500 MM

P = WINDDRUK
 P = PRESSION DU VENT
 P = WINDRUCK
 P = WIND PRESSURE
 FG = VLEUGELGEWICHT
 FG = POIDS DU VANTAIL
 FG = FLÜGELGEWICHT
 FG = WEIGHT OF THE VENT
 f = DOORBUIGING
 f = FLEXION
 f = DURCHBIEGUNG
 f = DEFLECTION

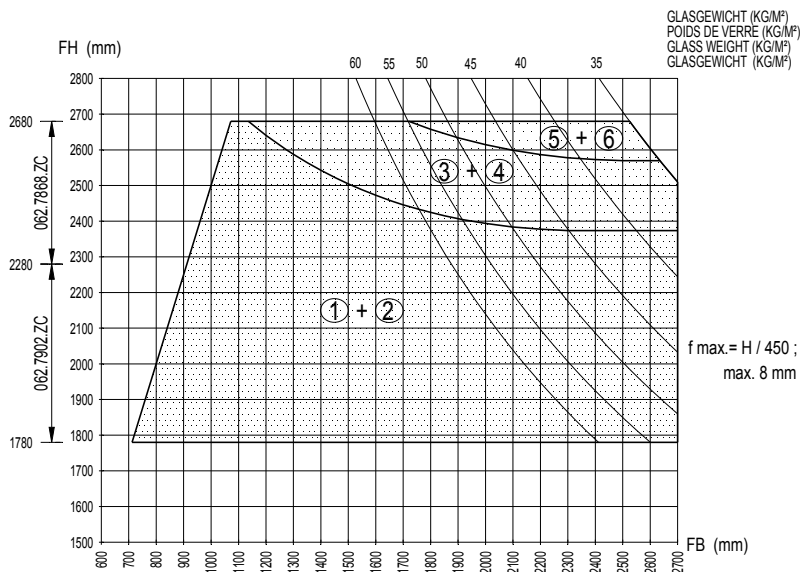
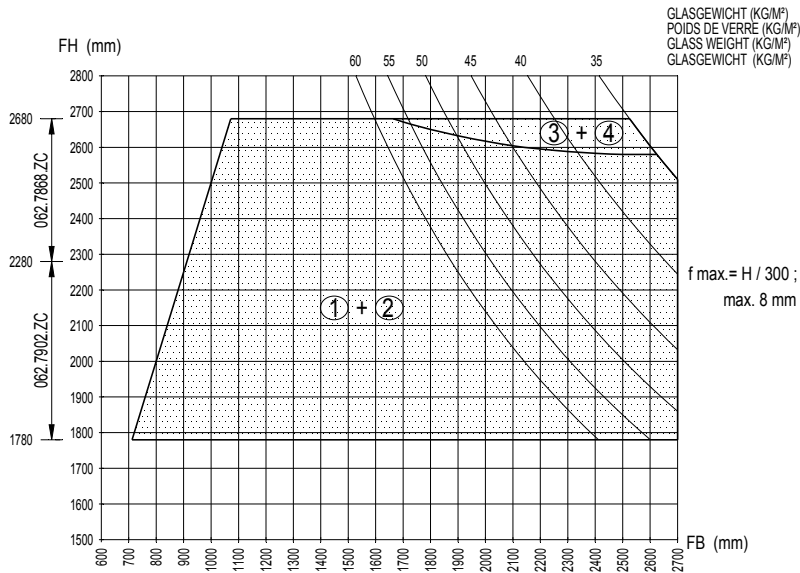

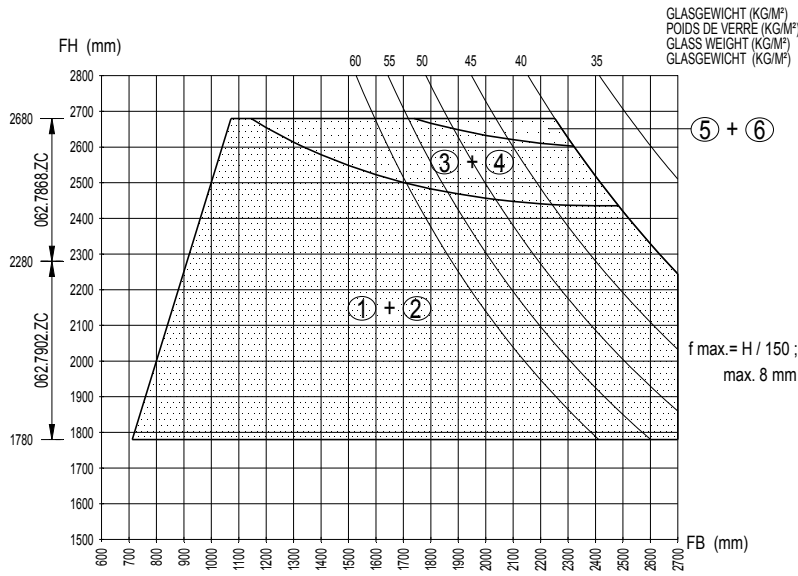

P = 800Pa
 FG max = 300KG
 FG max = 400KG*

* = ZIE BLZ 34.E. ...
 * = VOIR PAGES 34.E. ...
 * = SEE PAGES 34.E. ...
 * = SIEHE SEITEN 34.E. ...
 * FB MIN = 1500 MM

P = WINDDRUK
 P = PRESSION DU VENT
 P = WINDDRUCK
 P = WIND PRESSURE
 FG = VLEUGELGEWICHT
 FG = POIDS DU VAINTAIL
 FG = FLÜGELGEWICHT
 FG = WEIGHT OF THE VENT
 f = DOORBUIGING
 f = FLEXION
 f = DURCHBIEGUNG
 f = DEFLECTION

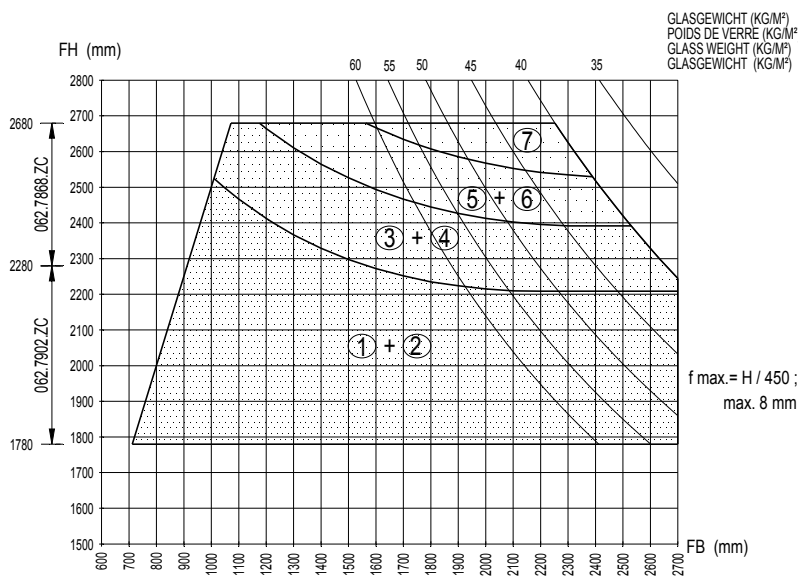
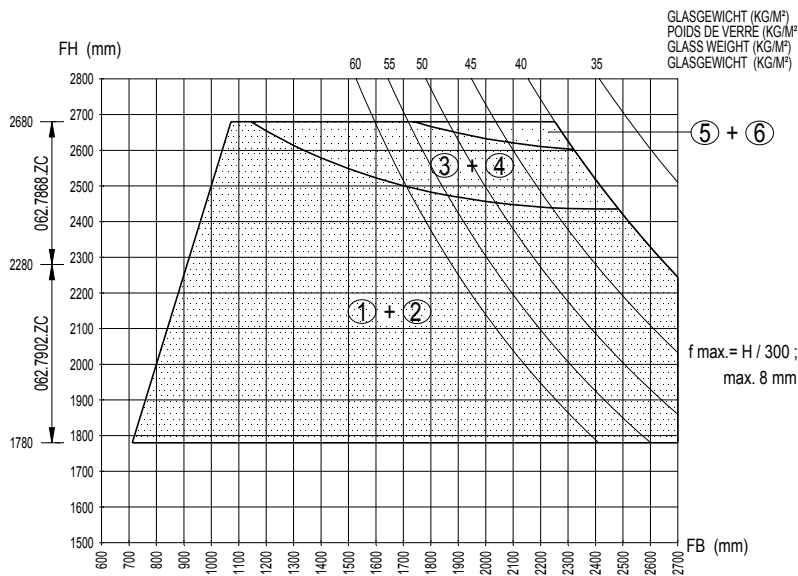

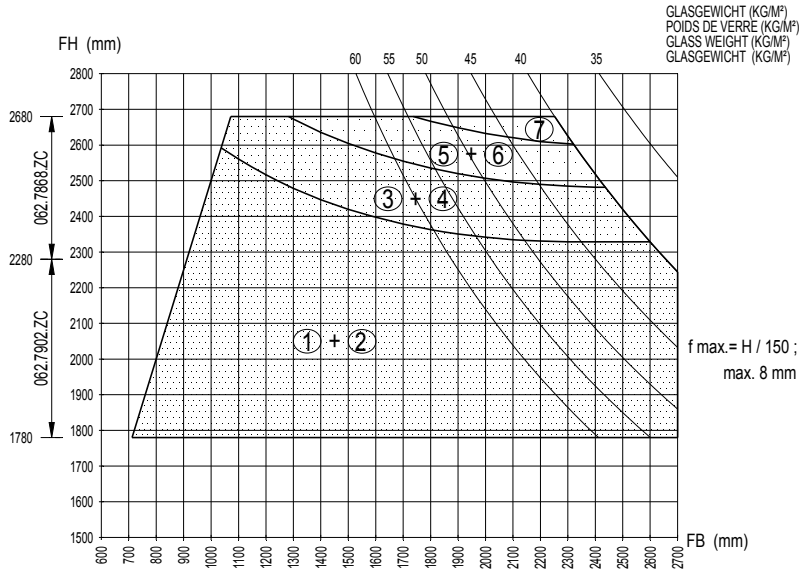

P = 1000Pa
 FG max = 300KG
 FG max = 400KG*

* = ZIE BLZ 34.E. ...
 * = VOIR PAGES 34.E. ...
 * = SEE PAGES 34.E. ...
 * = SIEHE SEITEN 34.E. ...
 * FB MIN = 1500 MM

P = WINDDRUK
 P = PRESSION DU VENT
 P = WINDRUCK
 P = WIND PRESSURE
 FG = VLEUGELGEWICHT
 FG = POIDS DU VANTAIL
 FG = FLÜGELGEWICHT
 FG = WEIGHT OF THE VENT
 f = DOORBUIGING
 f = FLEXION
 f = DURCHBIEGUNG
 f = DEFLECTION

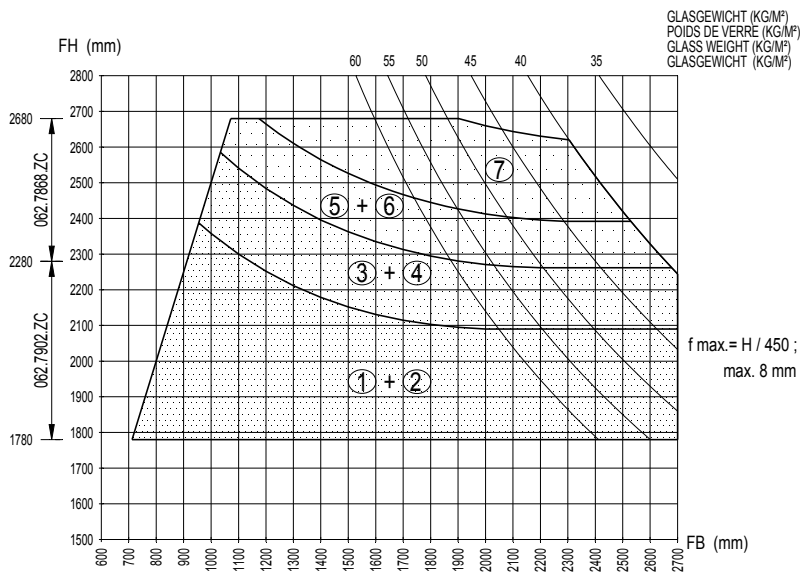
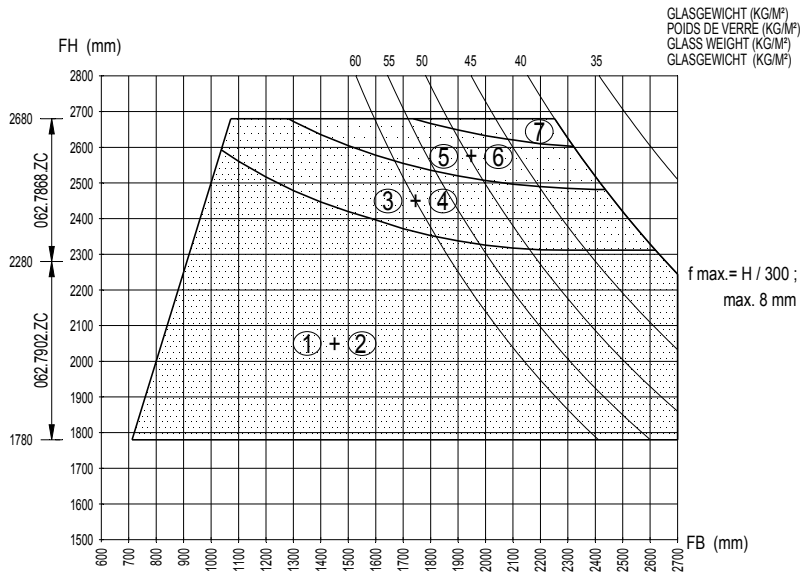

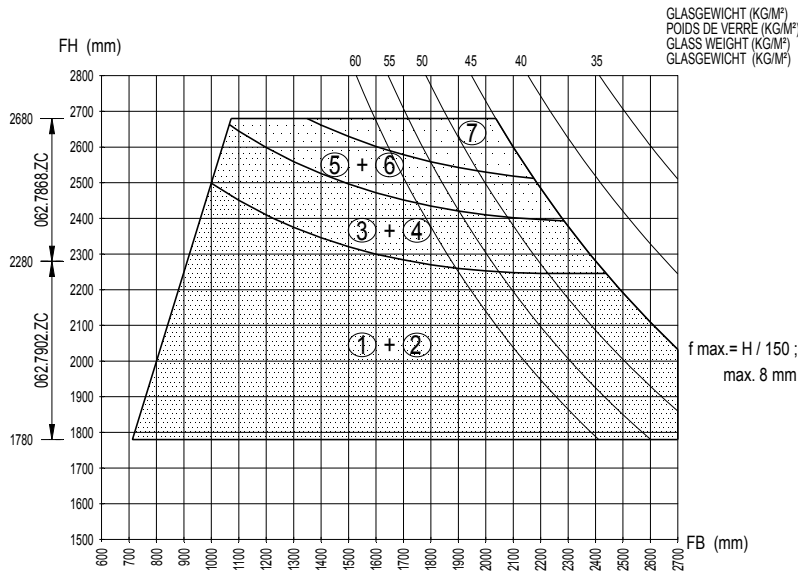

P = 1200Pa
 FG max = 300KG
 FG max = 400KG*

* = ZIE BLZ 34.E. ...
 * = VOIR PAGES 34.E. ...
 * = SEE PAGES 34.E. ...
 * = SIEHE SEITEN 34.E. ...
 * FB MIN = 1500 MM

P = WINDDRUK
 P = PRESSION DU VENT
 P = WINDRUCK
 P = WIND PRESSURE

FG = VLEUGELGEWICHT
 FG = POIDS DU VAINTAIL
 FG = FLÜGELGEWICHT
 FG = WEIGHT OF THE VENT

f = DOORBUIGING
 f = FLEXION
 f = DURCHBIEGUNG
 f = DEFLECTION

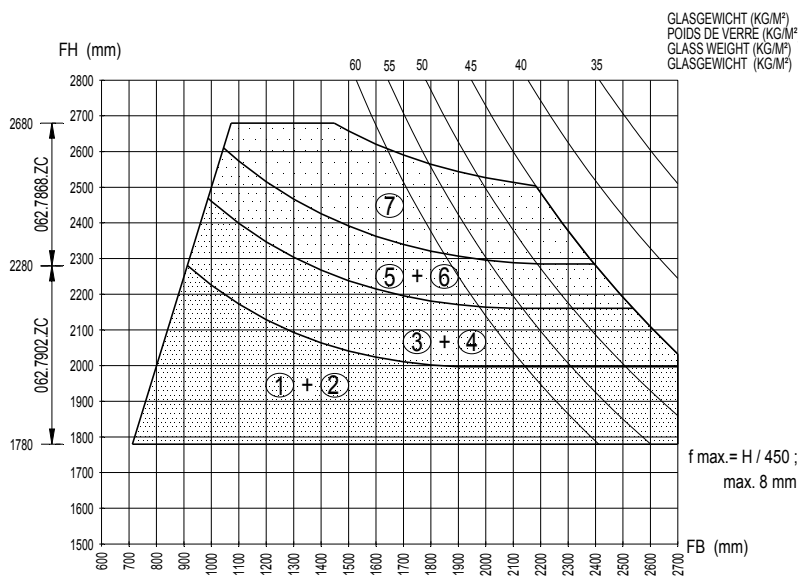
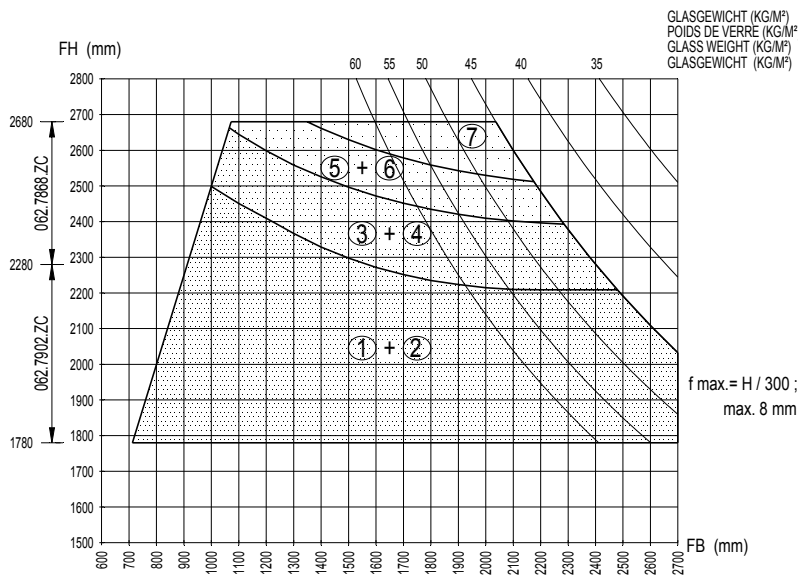

CP 155-LS

BASISSET AUTOMATISCHE HEFSCHUIFDEUR
 SET DE BASE SOULEV. COULISSANT AUTOMATIQUE
 BASIC SET AUTOMATIC LIFT AND SLIDING DOOR
 GRUNDKARTON AUTOMATISCHE HEBESCHIEBETUER

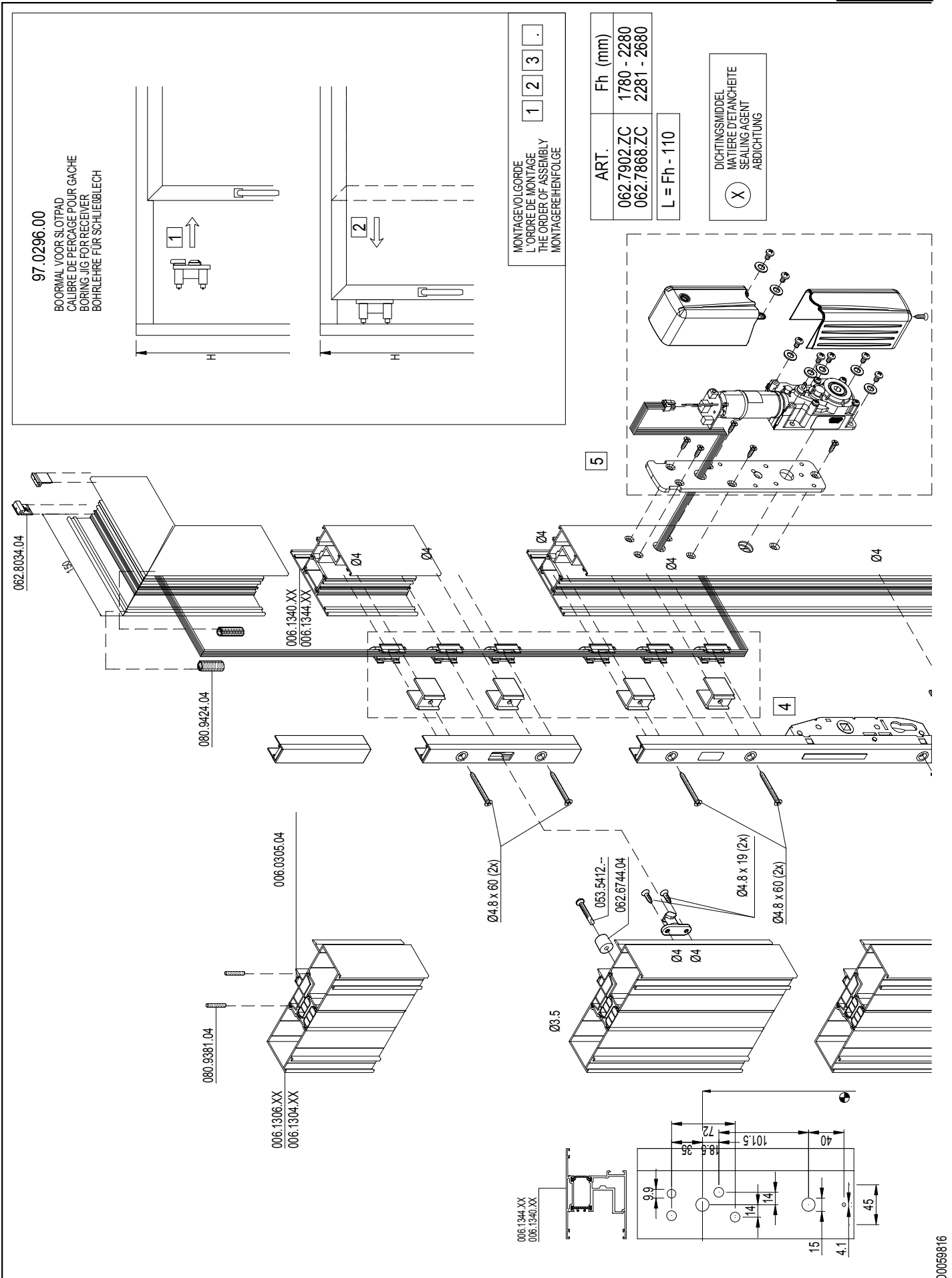

D0059816

CP 155-LS

BASISSET AUTOMATISCHE HEFSCHUIFDEUR
 SET DE BASE SOULEV. COULISSANT AUTOMATIQUE
 BASIC SET AUTOMATIC LIFT AND SLIDING DOOR
 GRUNDKARTON AUTOMATISCHE HEBESCHIEBETUER

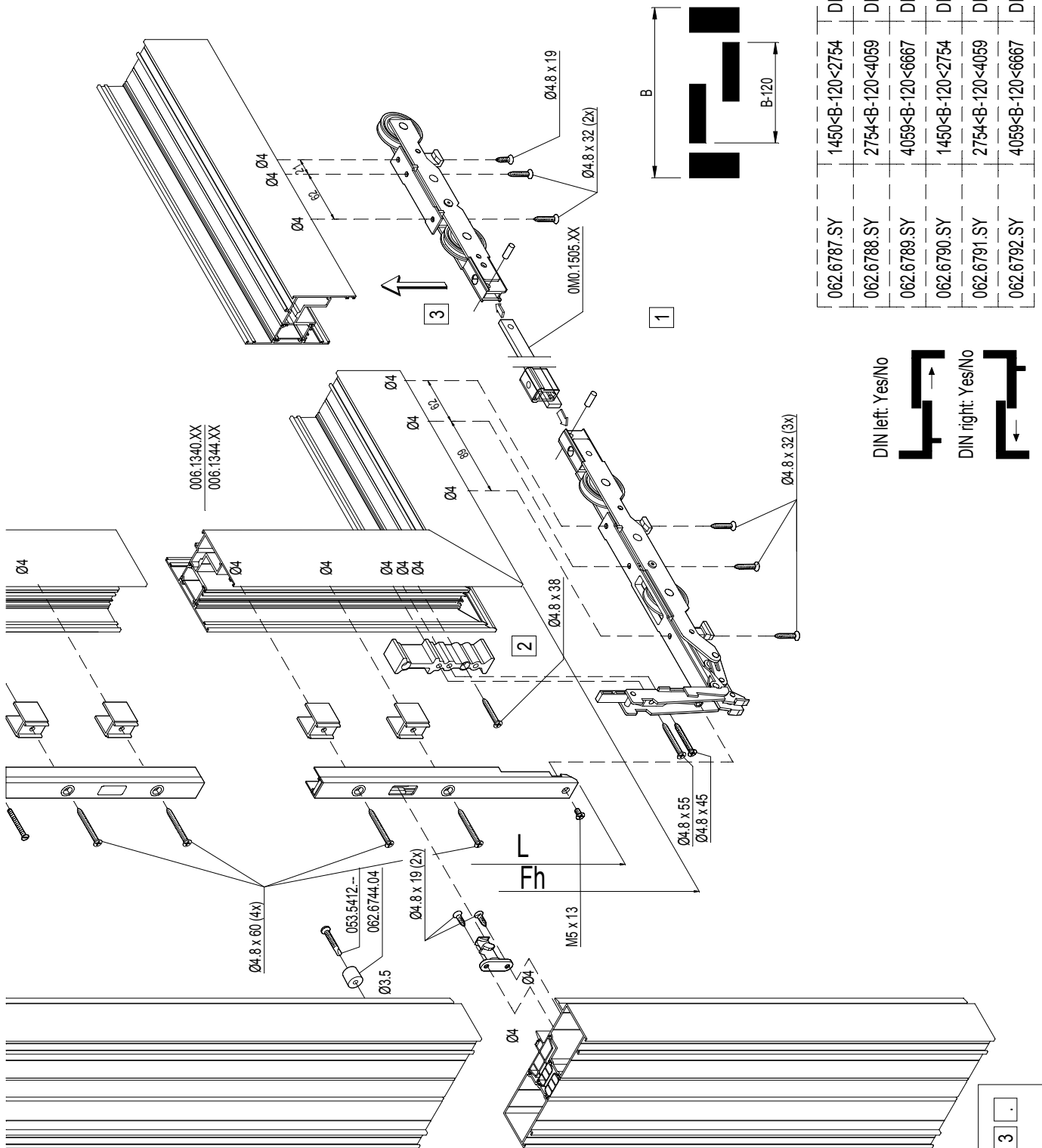

	DINL	DINL	DINL	DINR	DINR	DINR
062.6787.SY	1450<B-120<2754					
062.6788.SY		2754<B-120<4059				
062.6789.SY			4059<B-120<6667			
062.6790.SY	1450<B-120<2754					
062.6791.SY		2754<B-120<4059				
062.6792.SY			4059<B-120<6667			

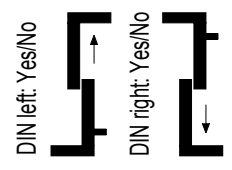

MONTAGEVOLGORDE
 L'ORDRE DE MONTAGE
 THE ORDER OF ASSEMBLY
 MONTAGEFOLGE

1 2 3

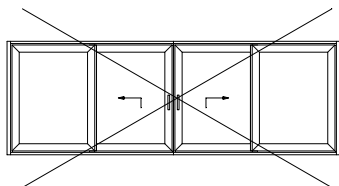

automatische schuifdeur enkel toepasbaar voor 2-rail (XQ), niet voor 4-rail
porte coulissante automatique seulement applicable pour 2-rail, pas pour 4-rail
automatic sliding door only for 2-rail, not for 4-rail
automatische Schiebetuer nur für 2-rail, nicht für 4-rail

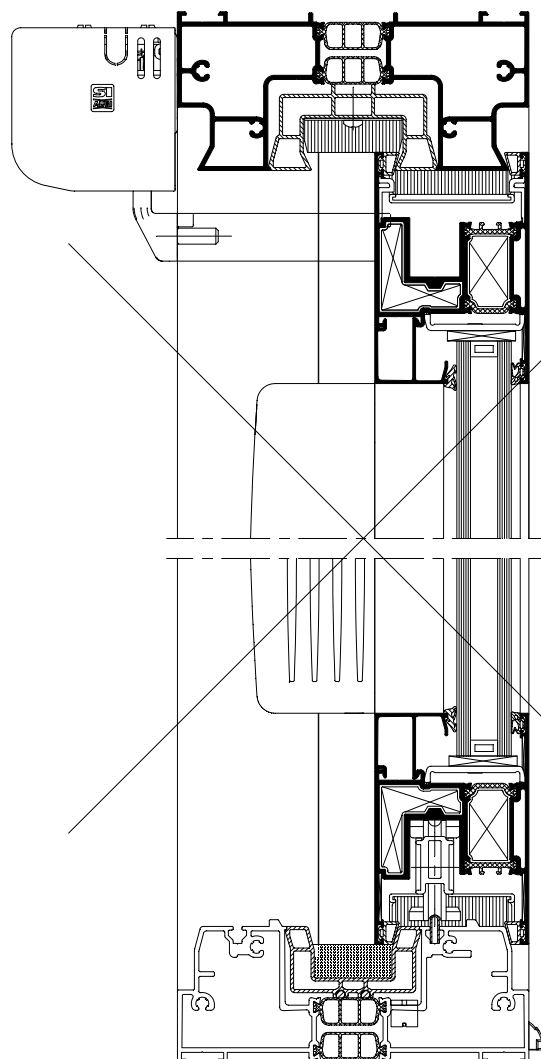
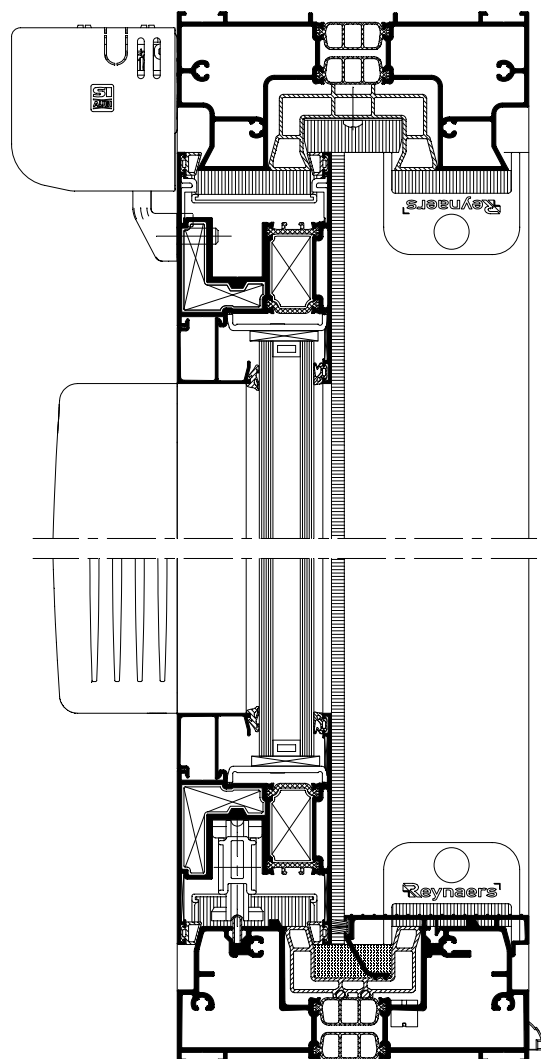

Automatic Lift and Sliding door accessories for CP 155-LS

(Please fill out in clear writing) and Fax to: +32 15 308 600

Order done for Reynaers ...

(e.g. BeLux, Germany, ...)

Client details:

- Name:
- Street:
- Town:
- Telephone nr.:
- Contact person:.....
- Fax:.....
- eMail:.....
- Alternative delivery adres:.....
- Repsonsible person for this region:.....
- Specific regulations:.....
- Amount of Lift and Slide doors (with the same dimensions):.....

Technical details for type XQ (or scheme A) solution

- Vent height:MM
- Vent width:MM
- Size A (RIB), base profile motor:MM (Between 775 and 6666MM)
For CP 155-LS, Size A = B-120MM

- Vent weight:kg

Type of XQ (or Scheme A) solution

- DIN left: Yes/No
- DIN right: Yes/No

General remarks

- One remote control is delivered as standard.
- Please consult System catalogue for min and max system dimensions.

SCP → SEND FORM to SIEGENIA-AUBI

Order number Siegenia-Aubi :

NIET BEHEERD KOPU

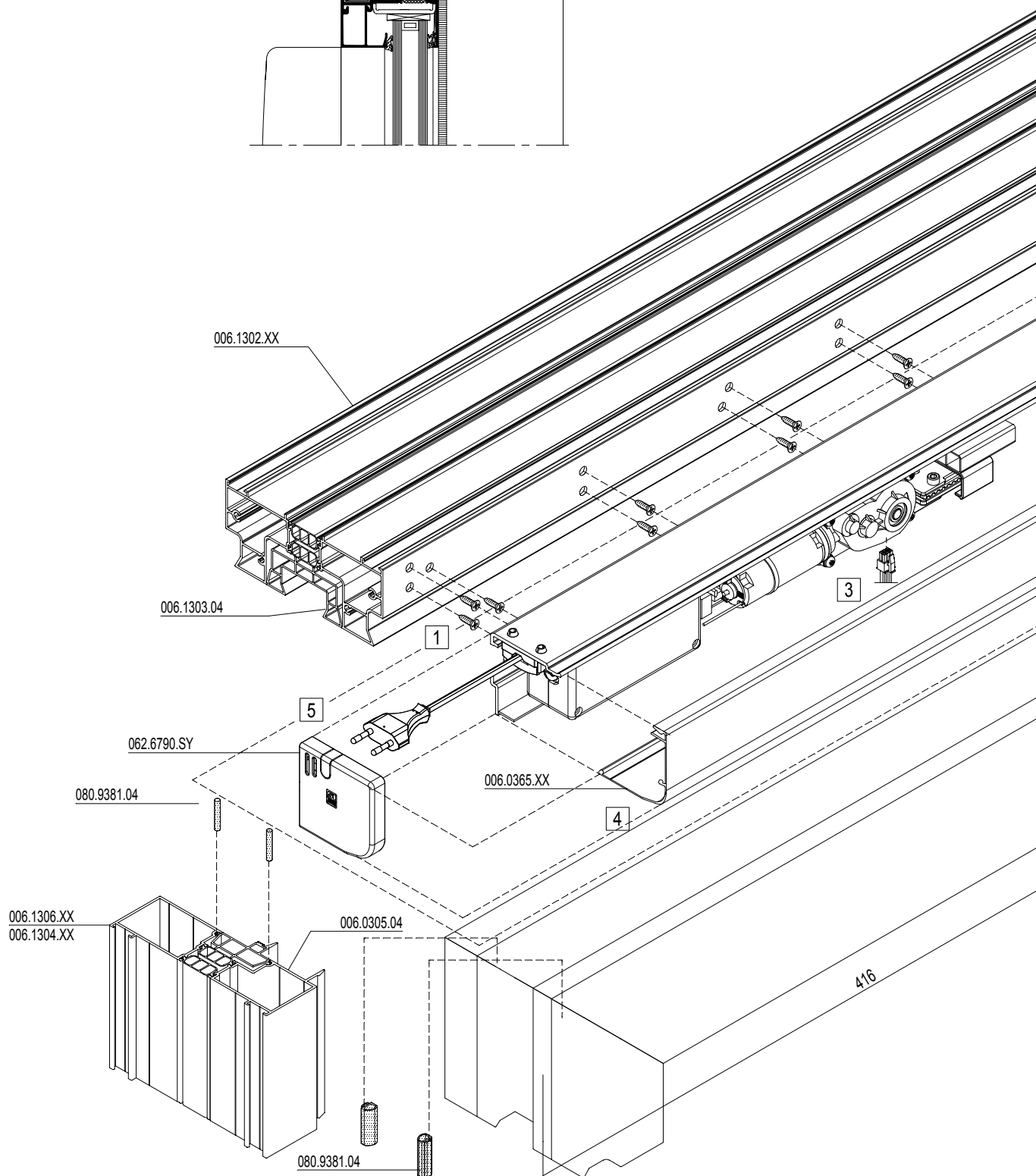
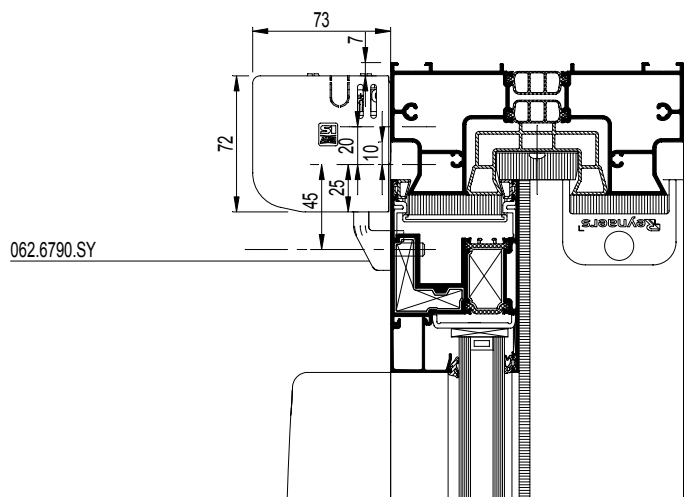

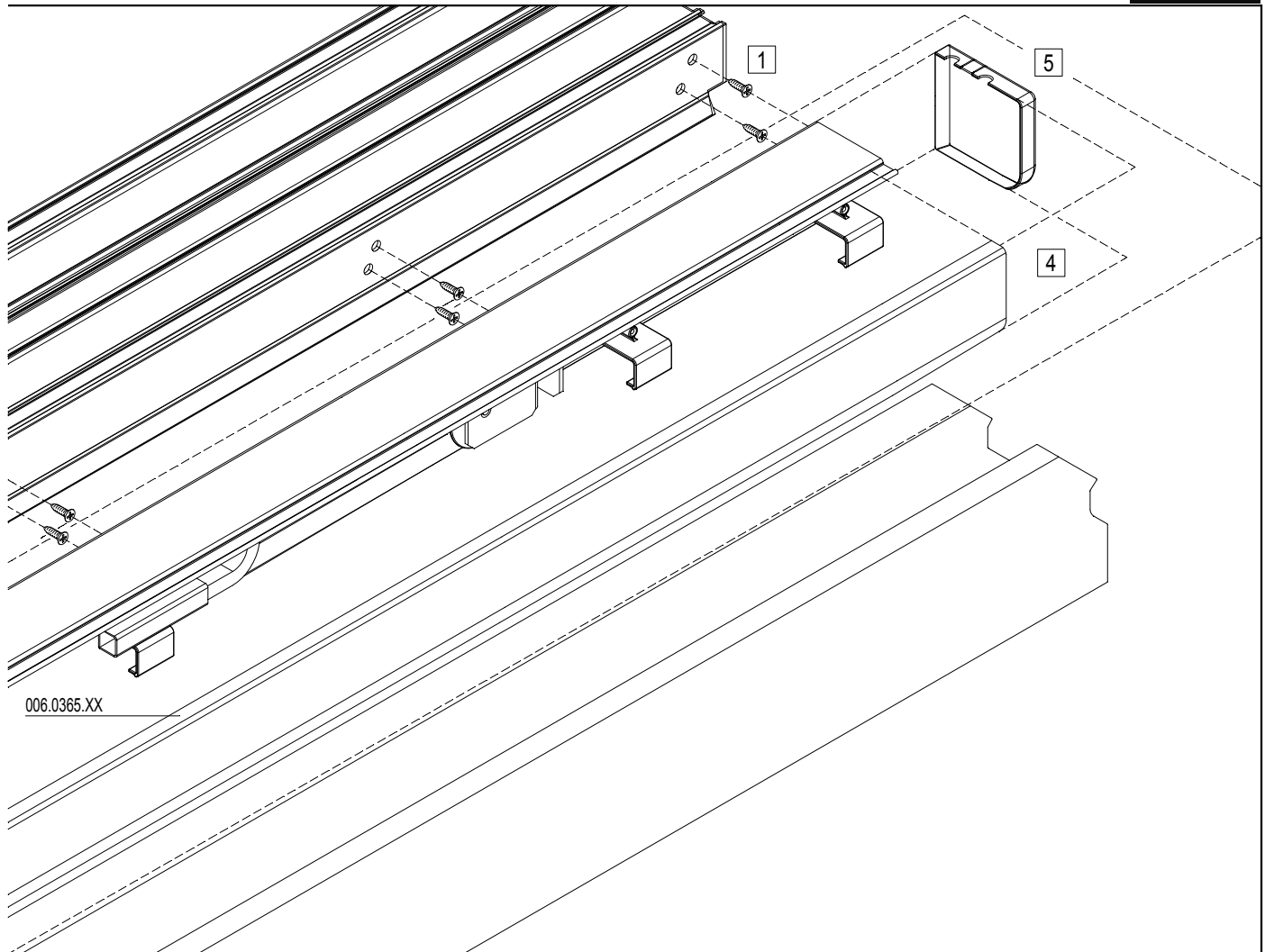

006.0365.XX

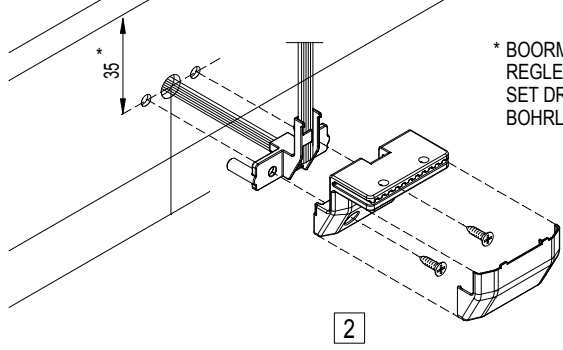

* BOORMAL 097.0683.07 OP POSITIE 35mm INSTELLEN
 REGLER CALIBRE DE PERÇAGE 097.0683.07 A POSITION 35mm
 SET DRILLING JIG 097.0683.07 TO POSITION 35mm
 BOHRLEHRE 097.0683.07 AUF POSITION 35mm EINSTELLEN

2

BOORMAL
 CALIBRE DE PERÇAGE
 BORING JIG
 BOHRLEHRE

097.0683.07

MONTAGEVOLGORDE
 L'ORDRE DE MONTAGE
 THE ORDER OF ASSEMBLY
 MONTAGEREIHENFOLGE

1 2 3 .

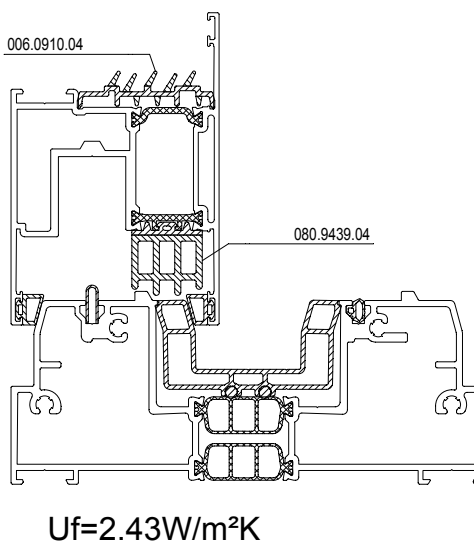
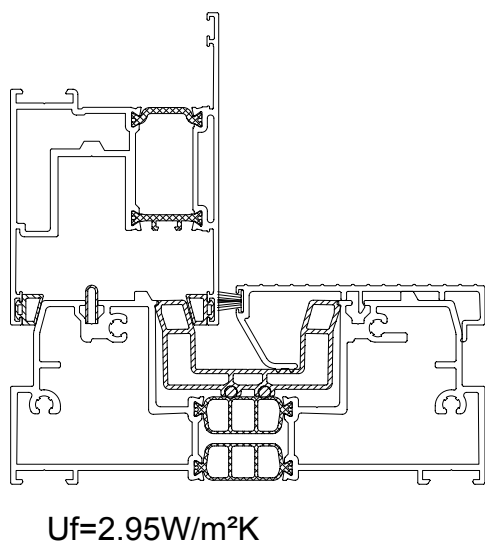
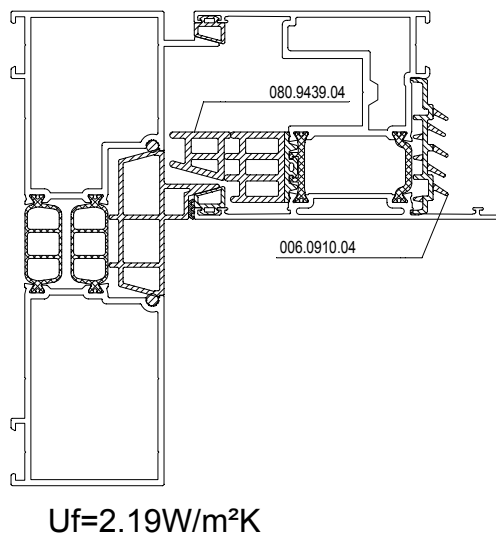
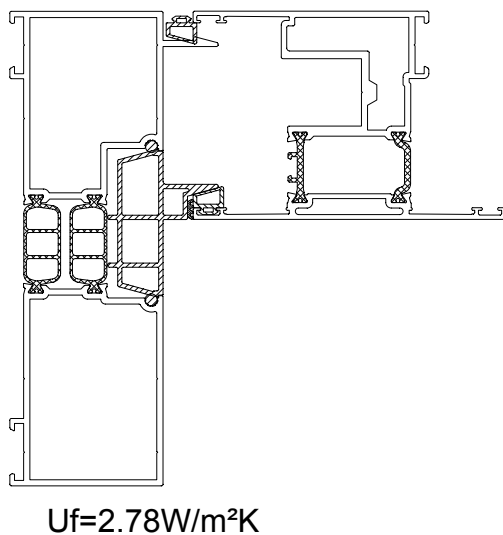
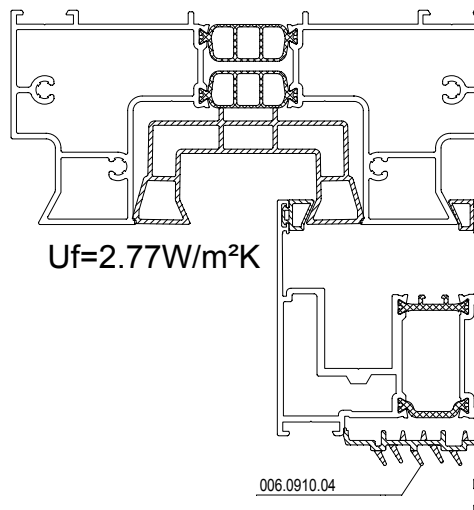
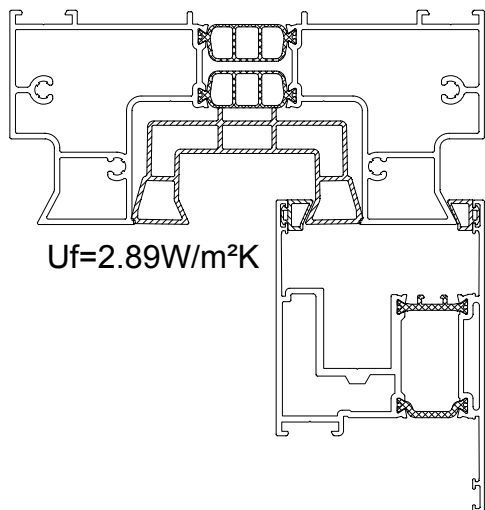

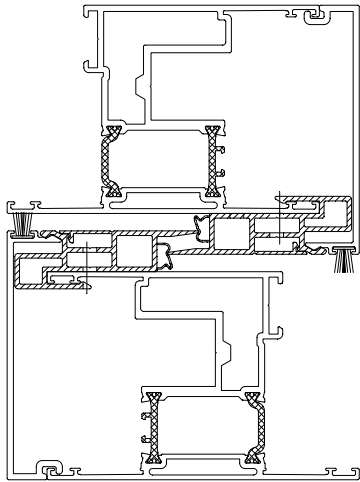

$U_f=3.74W/m^2K$

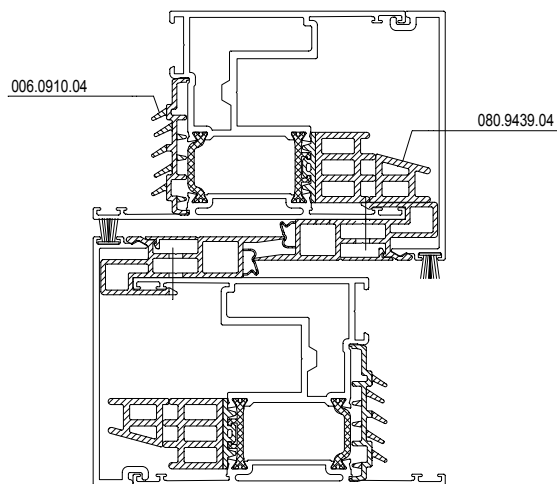

$U_f=3.5W/m^2K$

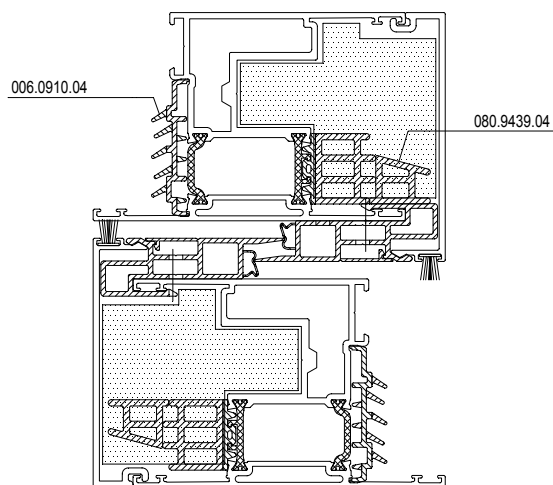

$U_f=3W/m^2K$

CP 155-LS

BASISSET AUTOMATISCHE HEFSCHUIFDEUR
SET DE BASE SOULEV. COULISSANT AUTOMATIQUE
BASIC SET AUTOMATIC LIFT AND SLIDING DOOR
GRUNDKARTON AUTOMATISCHE HEBESCHIEBETUER







G





Toebehoren





Accessoires

Accessories

Zubehör

Art. N°			Art. N°		
050.5153.--	34.G.014	D0014010	062.8027.04	34.G.047	D0014040
056.6209.04	34.G.040	D0014035	062.8036.04	34.G.046	D0014039
056.6297.00	34.G.049	D0014042	062.8037.04	34.G.046	D0014039
056.6298.01	34.G.049	D0014042	062.8038.07	34.G.040	D0014035
056.6299.--	34.G.049	D0014042	062.8039.07	34.G.040	D0014035
056.6301.--	34.G.049	D0014042	062.8045.04	34.G.039	D0014034
060.7090.XX	34.G.023	D0014020	062.8424.XX	34.G.025	D0014022
060.8723.--	34.G.010	D0014007	062.8425.ZC	34.G.027	D0014023
060.8725.00	34.G.010	D0014007	062.8426.ZC	34.G.027	D0014023
061.7038.--	34.G.029	D0014025	062.8427.XX	34.G.022	D0014019
061.7044.--	34.G.029	D0014025	062.8428.XX	34.G.022	D0014019
062.6744.04	34.G.036	D0014031	062.8429.--	34.G.022	D0014019
062.6787.SY	34.G.071	D0059648	062.8430.XX	34.G.024	D0014021
062.6788.SY	34.G.071	D0059648	062.8431.XX	34.G.024	D0014021
062.6789.SY	34.G.071	D0059648	062.8432.XX	34.G.024	D0014021
062.6790.SY	34.G.071	D0059648	062.8433.--	34.G.024	D0014021
062.6791.SY	34.G.071	D0059648	062.8434.--	34.G.028	D0014024
062.6792.SY	34.G.072	D0059652	062.8438.--	34.G.028	D0014024
062.6793.XX	34.G.072	D0059652	062.8440.XX	34.G.028	D0014024
062.6857.04	34.G.038	D0014033	062.8441.XX	34.G.028	D0014024
062.7715.XX	34.G.036	D0014031	062.9372.04	34.G.011	D0045257
062.7717.04	34.G.036	D0014031	062.9375.04	34.G.011	D0045257
062.7718.04	34.G.036	D0014031	062.9396.--	34.G.047	D0014040
062.7733.XX	34.G.022	D0014019	062.9397.--	34.G.047	D0014040
062.7800.04	34.G.034	D0014029	062.9399.04	34.G.047	D0014040
062.7834.--	34.G.035	D0014030	065.6555.04	34.G.037	D0014032
062.7861.XX	34.G.019	D0014017	068.5920.--	34.G.014	D0014010
062.7862.XX	34.G.019	D0014017	068.6351.04	34.G.038	D0014033
062.7863.XX	34.G.020	D0014018	068.7555.00	34.G.007	D0014004
062.7864.XX	34.G.020	D0014018	068.7558.00	34.G.007	D0014004
062.7865.XX	34.G.019	D0014017	068.7775.00	34.G.007	D0014004
062.7867.--	34.G.031	D0014027	068.8574.00	34.G.008	D0014005
062.7868.ZC	34.G.032	D0014028	068.8576.00	34.G.008	D0014005
062.7869.--	34.G.030	D0014026	068.8682.04	34.G.015	D0014013
062.7871.--	34.G.030	D0014026	068.8730.00	34.G.012	D0014008
062.7872.PA	34.G.019	D0014017	068.8731.00	34.G.012	D0014008
062.7894.04	34.G.039	D0014034	068.8732.00	34.G.013	D0014009
062.7902.ZC	34.G.032	D0014028	068.8733.00	34.G.013	D0014009
062.7903.--	34.G.031	D0014027	068.8734.00	34.G.014	D0014010
062.7927.04	34.G.039	D0014034	068.8786.00	34.G.016	D0014014
062.7937.--	34.G.033	D0075261	068.8787.00	34.G.017	D0014015
062.7961.ZC	34.G.026	D0075082	068.8788.00	34.G.018	D0014016
062.7962.ZC	34.G.026	D0075082	068.8835.00	34.G.008	D0014005
062.7963.XX	34.G.021	D0075081	069.6569.04	34.G.009	D0014006
062.7964.XX	34.G.021	D0075081	069.6575.04	34.G.009	D0014006
062.7965.XX	34.G.021	D0075081	069.6747.04	34.G.037	D0014032
062.8011.04	34.G.046	D0014039	069.6761.04	34.G.038	D0014033
062.8012.04	34.G.046	D0014039	069.6830.04	34.G.037	D0014032
062.8013.07	34.G.046	D0014039	069.8422.04	34.G.037	D0014032
062.8025.04	34.G.047	D0014040	069.8722.04	34.G.034	D0014029

Art. N°			Art. N°		
069.8724.04	34.G.034	D0014029			
071.6554.SY	34.G.039	D0014034			
080.8904.SY	34.G.041	D0014036			
080.9103.SY	34.G.041	D0014036			
080.9105.SY	34.G.041	D0014036			
080.9106.SY	34.G.042	D0014037			
080.9108.04	34.G.042	D0014037			
080.9114.SY	34.G.043	D0045280			
080.9116.04	34.G.043	D0045280			
080.9118.04	34.G.043	D0045280			
080.9253.04	34.G.044	D0014038			
080.9381.04	34.G.044	D0014038			
080.9424.04	34.G.044	D0014038			
080.9430.04	34.G.045	D0045283			
080.9439.04	34.G.045	D0045283			
080.9815.SY	34.G.045	D0045283			
081.9091.04	34.G.048	D0014041			
081.9092.04	34.G.048	D0014041			
081.9241.07	34.G.048	D0014041			
084.9061.--	34.G.056	D0014049			
084.9069.--	34.G.050	D0014043			
084.9070.--	34.G.056	D0014049			
084.9103.04	34.G.050	D0014043			
084.9105.--	34.G.050	D0014043			
084.9111.--	34.G.051	D0014044			
084.9113.--	34.G.051	D0014044			
084.9280.01	34.G.052	D0014045			
084.9350.01	34.G.052	D0014045			
084.9380.--	34.G.052	D0014045			
084.9480.--	34.G.052	D0014045			
084.9550.01	34.G.051	D0014044			
086.9150.--	34.G.052	D0014045			
086.9160.--	34.G.053	D0014046			
086.9175.--	34.G.053	D0014046			
086.9182.--	34.G.050	D0014043			
086.9203.--	34.G.053	D0014046			
086.9204.--	34.G.054	D0014047			
086.9393.--	34.G.053	D0014046			
086.9551.--	34.G.054	D0014047			
086.9600.XX	34.G.055	D0014048			
086.9610.--	34.G.054	D0014047			
086.9611.XX	34.G.055	D0014048			

Art. N°			Art. N°		
086.9191.--	34.G.073	D0014058			
095.30PN.00	34.G.088	D0046331			
095.A730.00	34.G.092	D0046335			
095.B323.00	34.G.092	D0046335			
095.B500.00	34.G.083	D0014067			
095.B531.00	34.G.084	D0046322			
095.B532.00	34.G.085	D0046323			
095.B533.00	34.G.085	D0046323			
095.B534.00	34.G.086	D0046324			
095.B561.00	34.G.086	D0046324			
095.B562.00	34.G.087	D0046328			
095.B565.00	34.G.087	D0046328			
097.0296.00	34.G.073	D0014058			
097.0377.00	34.G.074	D0014059			
097.0378.00	34.G.074	D0014059			
097.0393.00	34.G.076	D0014061			
097.0410.00	34.G.076	D0014061			
097.0436.00	34.G.077	D0014062			
097.0437.00	34.G.077	D0014062			
097.0440.00	34.G.079	D0014063			
097.0441.00	34.G.079	D0014063			
097.0454.00	34.G.075	D0014060			
097.0683.07	34.G.078	D0059656			
097.A200.00	34.G.089	D0046332			
097.C000.00	34.G.089	D0046332			
097.D000.00	34.G.089	D0046332			
097.D501.00	34.G.090	D0046330			
097.E800.00	34.G.090	D0046330			
097.E900.00	34.G.090	D0046330			
097.F800.00	34.G.094	D0014068			
097.F900.00	34.G.094	D0014068			
097.O900.00	34.G.082	D0074794			
097.P000.00	34.G.082	D0074794			
097.P100.00	34.G.080	D0074792			
097.P200.00	34.G.080	D0074792			
097.P800.00	34.G.081	D0074793			
097.P900.00	34.G.081	D0074793			
097.U300.00	34.G.093	D0075005			
097.U400.00	34.G.093	D0075005			

CP 155
CP 155-LS



CP 155 CP 155-LS

OVERZICHT
APERCU
OVERVIEW
UEBERSICHT



050.5153.-- (34.G.014)	056.6209.04 (34.G.040)	056.6297.00 (34.G.049)	056.6298.01 (34.G.049)	056.6299.-- (34.G.049)
056.6301.-- (34.G.049)	060.7090.XX (34.G.023)	060.8723.-- (34.G.010)	060.8725.00 (34.G.010)	061.7038.-- (34.G.029)
061.7044.-- (34.G.029)	062.6744.04 (34.G.036)	062.6787.SY (34.G.071)	062.6788.SY (34.G.071)	062.6789.SY (34.G.071)
062.6790.SY (34.G.071)	062.6791.SY (34.G.071)	062.6792.SY (34.G.072)	062.6793.XX (34.G.072)	062.6857.04 (34.G.038)
062.7715.XX (34.G.036)	062.7717.04 (34.G.036)	062.7718.04 (34.G.036)	062.7733.PA (34.G.022)	062.7800.04 (34.G.034)
062.7834.-- (34.G.035)	062.7861.PA (34.G.019)	062.7862.PA (34.G.019)	062.7863.PA (34.G.020)	062.7864.PA (34.G.020)
062.7865.PA (34.G.019)	062.7867.-- (34.G.031)	062.7868.ZC (34.G.032)	062.7869.-- (34.G.030)	062.7871.-- (34.G.030)

CP 155 CP 155-LS

OVERZICHT
APERCU
OVERVIEW
UEBERSICHT



062.7872.PA (34.G.019)	062.7894.04 (34.G.039)	062.7902.ZC (34.G.032)	062.7903.-- (34.G.031)	062.7927.04 (34.G.039)
062.7937.-- (34.G.033)	062.7961.ZC (34.G.026)	062.7962.ZC (34.G.026)	062.7963.PA (34.G.021)	062.7964.PA (34.G.021)
062.7965.PA (34.G.021)	062.8011.04 (34.G.046)	062.8012.04 (34.G.046)	062.8013.07 (34.G.046)	062.8025.04 (34.G.047)
062.8027.04 (34.G.047)	062.8036.04 (34.G.046)	062.8037.04 (34.G.046)	062.8038.07 (34.G.040)	062.8039.07 (34.G.040)
062.8045.04 (34.G.039)	062.8424.XX (34.G.025)	062.8425.ZC (34.G.027)	062.8426.ZC (34.G.027)	062.8427.PA (34.G.022)
062.8428.PA (34.G.022)	062.8429.-- (34.G.022)	062.8430.PA (34.G.024)	062.8431.PA (34.G.024)	062.8432.PA (34.G.024)
062.8433.-- (34.G.024)	062.8434.-- (34.G.028)	062.8438.-- (34.G.028)	062.8440.XX (34.G.028)	062.8441.XX (34.G.028)

CP 155 CP 155-LS

OVERZICHT
APERCU
OVERVIEW
UEBERSICHT



062.9372.04 (34.G.011)	062.9375.04 (34.G.011)	062.9396.-- (34.G.047)	062.9397.-- (34.G.047)	062.9399.04 (34.G.047)
065.6555.04 (34.G.037)	068.5920.-- (34.G.014)	068.6351.04 (34.G.038)	068.7555.00 (34.G.007)	068.7558.00 (34.G.007)
068.7775.00 (34.G.007)	068.8574.00 (34.G.008)	068.8576.00 (34.G.008)	068.8682.04 (34.G.015)	068.8730.00 (34.G.012)
068.8731.00 (34.G.012)	068.8732.00 (34.G.013)	068.8733.00 (34.G.013)	068.8734.00 (34.G.014)	068.8786.00 (34.G.016)
068.8786.00 (34.G.016)	068.8787.00 (34.G.017)	068.8787.00 (34.G.017)	068.8788.00 (34.G.018)	068.8788.00 (34.G.018)
068.8835.00 (34.G.008)	069.6569.04 (34.G.009)	069.6575.04 (34.G.009)	069.6747.04 (34.G.037)	069.6761.04 (34.G.038)
069.6830.04 (34.G.037)	069.8422.04 (34.G.037)	069.8722.04 (34.G.034)	069.8724.04 (34.G.034)	071.6554.SY (34.G.039)

CP 155 CP 155-LS

OVERZICHT
APERCU
OVERVIEW
UEBERSICHT



080.8904.SY (34.G.041)	080.9103.SY (34.G.041)	080.9105.SY (34.G.041)	080.9106.SY (34.G.042)	080.9108.04 (34.G.042)
080.9114.SY (34.G.043)	080.9116.04 (34.G.043)	080.9118.04 (34.G.043)	080.9253.04 (34.G.044)	080.9381.04 (34.G.044)
080.9424.04 (34.G.044)	080.9430.04 (34.G.045)	080.9439.04 (34.G.045)	080.9815.SY (34.G.045)	081.9091.04 (34.G.048)
081.9092.04 (34.G.048)	081.9241.07 (34.G.048)	084.9061.-- (34.G.056)	084.9069.-- (34.G.050)	084.9070.-- (34.G.056)
084.9103.04 (34.G.050)	084.9105.-- (34.G.050)	084.9111.-- (34.G.051)	084.9113.-- (34.G.051)	084.9380.-- (34.G.052)
084.9480.-- (34.G.052)	084.9550.01 (34.G.051)	086.9150.-- (34.G.052)	086.9160.-- (34.G.053)	086.9175.-- (34.G.053)
086.9182.-- (34.G.050)	086.9191.-- (34.G.073)	086.9203.-- (34.G.053)	086.9204.-- (34.G.054)	086.9393.-- (34.G.053)

CP 155 CP 155-LS

OVERZICHT
APERCU
OVERVIEW
UEBERSICHT



086.9551.-- (34.G.054)	086.9600.XX (34.G.055)	086.9610.-- (34.G.054)	086.9611.XX (34.G.055)	095.30PN.00 (34.G.088)
095.A730.00 (34.G.092)	095.B323.00 (34.G.092)	095.B500.00 (34.G.083)	095.B531.00 (34.G.084)	095.B532.00 (34.G.085)
095.B533.00 (34.G.085)	095.B534.00 (34.G.086)	095.B561.00 (34.G.086)	095.B562.00 (34.G.087)	095.B565.00 (34.G.087)
097.0296.00 (34.G.073)	097.0377.00 (34.G.074)	097.0378.00 (34.G.074)	097.0393.00 (34.G.076)	097.0410.00 (34.G.076)
097.0436.00 (34.G.077)	097.0437.00 (34.G.077)	097.0440.00 (34.G.079)	097.0441.00 (34.G.079)	097.0454.00 (34.G.075)
097.0683.07 (34.G.078)	097.A200.00 (34.G.089)	097.C000.00 (34.G.089)	097.D000.00 (34.G.089)	097.D501.00 (34.G.090)
097.E800.00 (34.G.090)	097.E900.00 (34.G.090)	097.F800.00 (34.G.094)	097.F900.00 (34.G.094)	097.O900.00 (34.G.082)

Toebehoren
Accessoires
Accessoires
Zubehör

34.G.005
02/2009

D0075504

CP 155 CP 155-LS

PERSHOEKEN
EQUERRES A SERTIR
CRIMP CORNER CLEATS
PRESSECKWINKEL

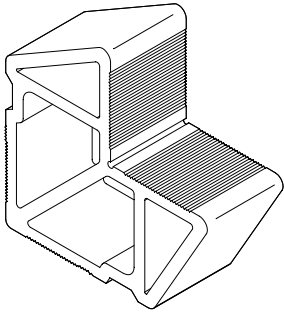
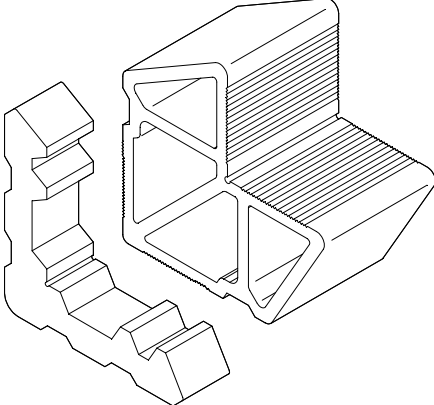
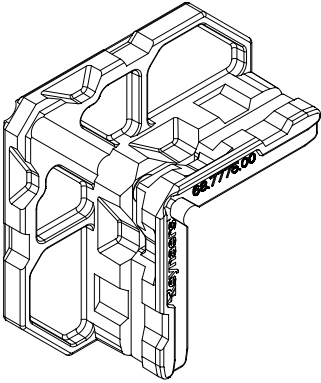

	<p>068.7555.00</p> <p>PERSHOEK 39.2x28.3</p> <p>EQUERRE A SERTIR 39.2x28.3</p> <p>CRIMP CORNER CLEAT 39.2x28.3</p> <p>PRESSECKWINKEL 39.2x28.3</p>	<p>CP 155 006.1300.XX 006.1400.XX</p> <p>CP 155-LS 006.1300.XX 006.1400.XX</p> <p>CP 155-AP CP 155-LS/AP</p>		
	<p>068.7558.00</p> <p>PERSHOEKEN</p> <p>EQUERRES A SERTIR</p> <p>CRIMP CORNER CLEATS</p> <p>PRESSECKWINKEL</p>	<p>CP 155 006.0320.XX</p>		
	<p>068.7775.00</p> <p>PERSHOEK 39.2x36.1</p> <p>EQUERRE A SERTIR 39.2x36.1</p> <p>CRIMP CORNER CLEAT 39.2x36.1</p> <p>PRESSECKWINKEL 39.2x36.1</p>	<p>CP 155 006.1340.XX</p> <p>CP 155-LS 006.1340.XX</p> <p>CP 155-AP CP 155-LS/AP</p>		

CP 155 CP 155-LS

SCHROEFHOEKEN
EQUERRES A VISSER
SCREW CORNER CLEATS
SCHRAUBECKWINKEL



	<p>068.8574.00 SCHROEFHOEKEN EQUERRES A VISSER SCREW CORNER CLEATS SCHRAUBECKWINKEL</p>	<p>CP 155 006.0320.XX TP 138</p>	
	<p>068.8576.00 SCHROEFHOEK 39.2x28.3 EQUERRE A VISSER 39.2x28.3 SCREW CORNER CLEAT 39.2x28.3 SCHRAUBECKWINKEL 39.2x28.3</p>	<p>CP 155 006.1300.XX 006.1400.XX CP 155-LS 006.1300.XX 006.1400.XX CP 155-AP CP 155-LS/AP</p>	<p>2 st./pc 050.5091.- - M8 x 10</p>
	<p>068.8835.00 SCHROEFHOEKEN 39.2x36.1 EQUERRES A VISSER 39.2x36.1 SCREW CORNER CLEATS 39.2x36.1 SCHRAUBECKWINKEL 39.2x36.1</p>	<p>CP 155 006.1340.XX CP 155-LS 006.1340.XX CP 155-AP CP 155-LS/AP</p>	<p>2 st./pc 068.5938.- - Ø4 x 60</p>

CP 155 CP 155-LS

VULHOEKEN
EQUERRES DE REMPLISSAGE
CORNER SUPPORTS
FUELLECKWINKEL

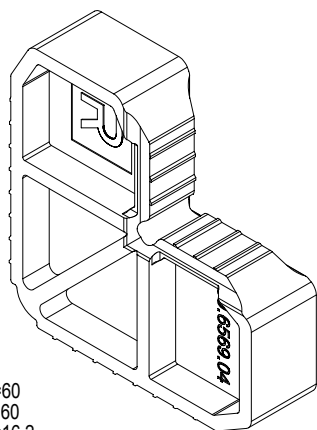

H=60
B=60
D=16.2

069.6569.04

VULHOEK

EQUERRE DE REMPLISSAGE

CORNER SUPPORT

FUELLECKWINKEL

CP 155
006.1340.XX

CP 155-LS
006.1340.XX

CP 155-AP
CP 155-LS/AP

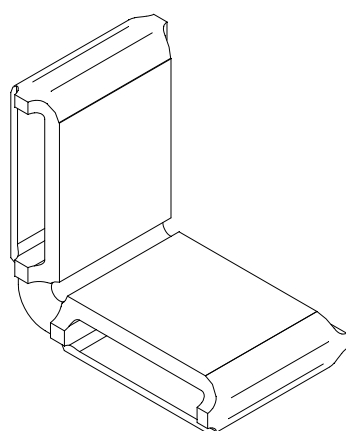

069.6575.04

VULHOEK
26x9.1MM

EQUERRE DE REMPLISSAGE
26x9.1MM

CORNER SUPPORT
26x9.1MM

FUELLECKWINKEL
26x9.1MM

CP 155
006.0320.XX

CP 130

CS 77



060.8723.--

STEUNHOEK

CALE DE FEUILLURE

REBATE SUPPORT

ECKWINKEL

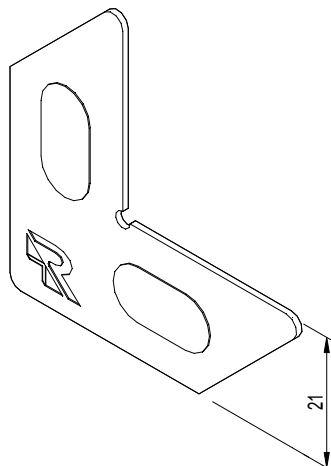

H=107.3
B=107.3
D=1

CP 155	CS 59	CS 77-BP			
006.0320.XX	CS 59-HV	CS 77-FP			
006.1340.XX	CS 59-Re	CP 155-AP			
008.3113.XX	CS 59-So	CP 155-LS/AP			
008.3114.XX	CS 59-AD	CP 96			
008.3120.XX	CS 59-CD	CW 60-DRL			
008.3123.XX	CS 59-SD	CP 96-LS			
008.3824.XX	CS 68	CP 96-AP			
0K8.3824.XX	CS 68-HV	CP 96-LS/AP			
	CS 68-Re	TP 110-Re			
CP 155-LS	CS 68-So	CS 68 Optima			
006.1340.XX	TP 110	Eco system			
008.3113.XX	CW 50	CS 38-SL			
008.3114.XX	CW 50-HI	CS 86-HI			
008.3120.XX	CW 60	CS 38-SL/AP			
008.3123.XX	TR 200	BS 40			
008.3824.XX	CS 68-FP				
0K8.3824.XX	CR 120				
	CS 77				
CS 59Pa	CS 77-HV				

060.8725.00

STEUNHOEK

CALE DE FEUILLURE

REBATE SUPPORT

ECKWINKEL

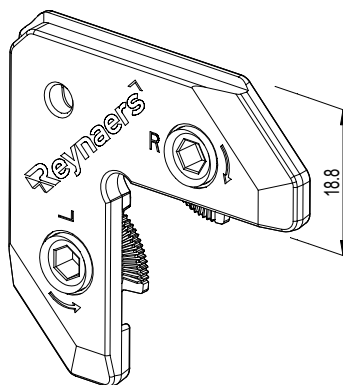

H=18.8
B=50
D=4.7

CP 155	CS 59Pa	CP 155-AP			
006.0320.XX	CS 59	CP 155-LS/AP			
006.1340.XX	CS 59-HV	CP 96			
008.0114.XX	CS 59-Re	CW 60-DRL			
008.3113.XX	CS 59-So	CP 96-LS			
008.3114.XX	CS 59-AD	TP 110-Re			
008.3120.XX	CS 59-CD	CS 86-HI			
008.3123.XX	CS 59-SD	BS 40			
008.3824.XX	CS 68				
0K8.3824.XX	CS 68-Re	CS 38-SL			
	CS 68-So	CS 38-SL/AP			
CP 155-LS	TP 110				
006.1340.XX	CW 50				
008.3113.XX	CW 50-HI				
008.3114.XX	CW 60				
008.3120.XX	CS 68-FP				
008.3123.XX	CS 77				
008.3824.XX	CS 77-HV				
0K8.3824.XX	CS 77-BP				
	CS 77-FP				

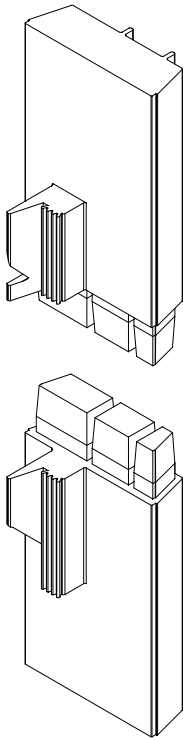

062.9372.04

SET EINDSTUKKEN

SET PIECES FINALES

SET END PIECES

SATZ ENDKAPPEN

CP 155-LS
006.0305.04

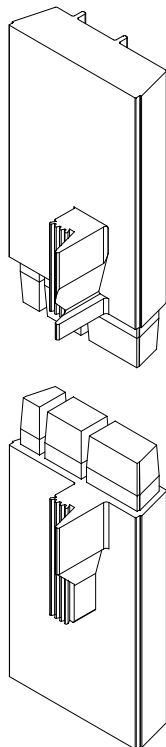

062.9375.04

SET EINDSTUKKEN

SET PIECES FINALES

SET END PIECES

SATZ ENDKAPPEN

CP 155-LS
006.0305.04

CP 155 CP 155-LS

T-VERBINDING
RACCORDEMENT-T
T-CONNECTION
T-VERBINDUNG



068.8730.00

T-VERBINDER
5x14MM

JONCTION-T
5x14MM

T-BRACKET
5x14MM

T-VERBINDER
5x14MM

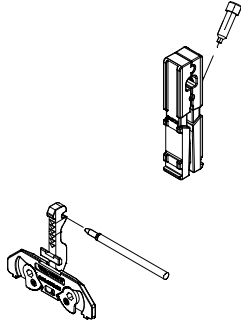

CP 155
008.3113.XX

CP 155-LS
008.3113.XX

CS 59
CS 59-HV
CS 59-Re
CS 59-So
CS 68
CS 68-HV
CS 68-Re
CS 68-So
TP 110
CW 50
CW 50-HI
CW 60
CS 68-FP
CS 77

CS 77-HV
CW 60-DRL
CS 86-HI

CS 59-AD
CS 59-CD
CS 59-SD
CS 59-AP
CS 68-AP
CS 77-AP
CS 77-BP

1 st./pc
068.5938.--

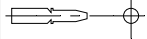

Ø4 x 60



1 st./pc
050.5153.--

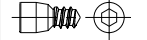

4.8 x 13.8



1 st./pc
068.5920.--

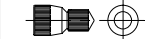

REYNAERS
4 x 14

050.5153.-- = T-connection screw
068.5920.-- = T-connection drive pin

068.8731.00

T-VERBINDER
17.7x25.8MM

JONCTION-T
17.7x25.8MM

T-BRACKET
17.7x25.8MM

T-VERBINDER
17.7x25.8MM

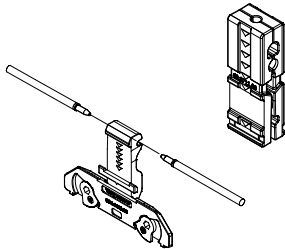

CP 155
008.3120.XX

CP 155-LS
008.3120.XX

CS 59
CS 59-HV
CS 59-Re
CS 59-So
CS 68
CS 68-HV
CS 68-Re
CS 68-So
TP 110
CS 68-FP
CS 77
CS 77-HV
CS 86-HI

2 st./pc
068.5938.--

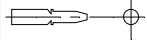

Ø4 x 60



2 st./pc
050.5153.--

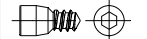

4.8 x 13.8



2 st./pc
068.5920.--

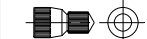

REYNAERS
4 x 14

050.5153.-- = T-connection screw
068.5920.-- = T-connection drive pin

CP 155 CP 155-LS

T-VERBINDING
RACCORDEMENT-T
T-CONNECTION
T-VERBINDUNG

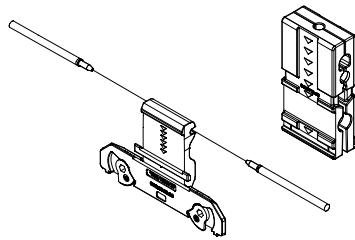

068.8732.00

T-VERBINDER
30.9x38.8MM

JUNCTION-T
30.9x38.8MM

T-BRACKET
30.9x38.8MM

T-VERBINDER
30.9x38.8MM

CP 155	CS 59-So				
008.0114.XX	CS 59-AD				
008.3114.XX	CS 59-CD				
	CS 59-SD				
CP 155-LS	CS 68-Re				
008.3114.XX	CS 68-So				
	CS 59-AP				
	CS 68-AP				
	CS 77-AP				

CS 59
CS 59-HV
CS 68
CS 68-HV
TP 110
CS 68-FP
CS 77
CS 77-HV
CS 77-BP
CS 77-FP
CS 86-HI

CS 59-Re



050.5153.-- = T-connection screw
068.5920.-- = T-connection drive pin

2 st./pc
068.5938.--

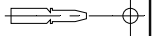

Ø4 x 60



2 st./pc
050.5153.--

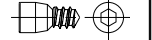

4.8 x 13.8



2 st./pc
068.5920.--

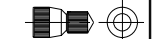

REYNAERS
4 x 14

068.8733.00

T-VERBINDER
43.9x38.8MM

JUNCTION-T
43.9x38.8MM

T-BRACKET
43.9x38.8MM

T-VERBINDER
43.9x38.8MM

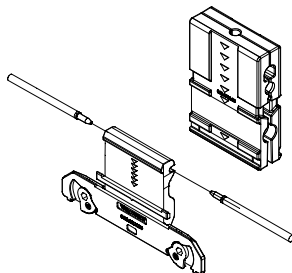

CP 155	CS 68-Re				
008.3123.XX	CS 68-So				
	CS 77-HV				
CP 155-LS	CS 59-AP				
008.3123.XX	CS 68-AP				
	CS 77-AP				
	CS 77-BP				

CS 59
CS 68
TP 110
CS 68-FP
CS 77
CS 86-HI

CS 59-HV
CS 59-Re
CS 59-So
CS 59-AD
CS 59-CD
CS 59-SD
CS 68-HV



050.5153.-- = T-connection screw
068.5920.-- = T-connection drive pin

2 st./pc
068.5938.--

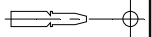

Ø4 x 60



2 st./pc
050.5153.--

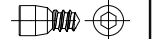

4.8 x 13.8



2 st./pc
068.5920.--

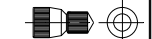

REYNAERS
4 x 14

CP 155 CP 155-LS

T-VERBINDER
JUNCTION-T
T-BRACKET
T-VERBINDER

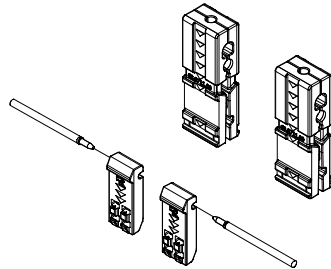

068.8734.00

T-VERBINDER
2x 17.9x25.8MM

JUNCTION-T
2x 17.9x25.8MM

T-BRACKET
2x 17.9x25.8MM

T-VERBINDER
2x 17.9x25.8MM

CP 155
008.3824.XX
0K8.3824.XX

CP 155-LS
008.3824.XX
0K8.3824.XX

CS 59
CS 59-AD
CS 68
CS 68-FP
CS 77
CS 86-HI

2 st./pc
068.5938.--



Ø4 x 60



2 st./pc
050.5153.--

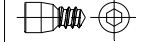

4.8 x 13.8



2 st./pc
068.5920.--

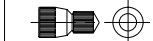

REYNAERS
4 x 14

050.5153.-- = T-connection screw
068.5920.-- = T-connection drive pin

050.5153.--

SCHROEF
4.8x13.8MM

VIS
4.8x13.8MM

SCREW
4.8x13.8MM

SCHRAUBE
4.8x13.8MM

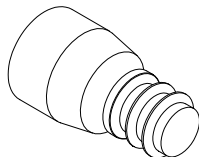

CP 155
008.0114.XX
008.3113.XX
008.3114.XX
008.3120.XX
008.3123.XX
008.3824.XX
0K8.3824.XX

CP 155-LS
008.3113.XX
008.3114.XX
008.3120.XX
008.3123.XX
008.3824.XX
0K8.3824.XX

CS 59
CS 59-HV
CS 59-Re
CS 59-So
CS 59-AD
CS 68
CS 68-HV
CS 68-Re
CS 68-So
TP 110

CW 50
CW 50-HI
CW 60
CS 68-FP
CS 77
CS 77-HV
CS 77-BP
CS 77-FP
CW 60-DRL
TP 110-Re
CS 86-HI

CS 59-CD
CS 59-SD
CS 59-AP
CS 68-AP
CS 77-AP

068.5920.--

NAGEL T-VERBINDER
Ø7mm

CLOU JUNCTION-T
Ø7mm

DRIVE PIN T-BRACKET
Ø7mm

STIFT T-VERBINDER
Ø7mm

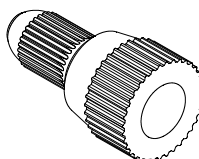

CS 59
CS 59-HV
CS 59-Re
CS 59-So
CS 59-AD
CS 59-CD
CS 59-SD
CS 68
CS 68-HV
CS 68-Re
CS 68-So
CP 155
CP 155-LS

CS 68-FP
CS 77
CS 77-HV
CS 59-AP
CS 68-AP
CS 77-AP
CS 77-BP
CS 86-HI

CP 155 CP 155-LS

AFDICHTINGSSTUK T-VERBINDER
PIECE D'ETANCHEITE JONCTION-T
SEALING T-BRACKET
ABDICHTUNG T-VERBINDER

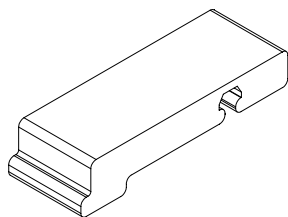

068.8682.04

AFDICHTINGSSTUK T-VERBINDER

PIECE D'ETANCHEITE JONCTION-T

SEALING T-BRACKET

ABDICHTUNG T-VERBINDER

CP 155
008.0114.XX
008.3113.XX
008.3114.XX
008.3120.XX
008.3123.XX
008.3824.XX

CP 155-LS
008.3113.XX
008.3114.XX
008.3120.XX
008.3123.XX
008.3824.XX

CW 50
CW 60
CS 77
CS 77-HV
CS 77-BP
CS 77-FP

B=13.5
D=41.7

CP 155 CP 155-LS

T-VERBINDER VERSTELBAAR
JONCTION-T REGLABLE
T-BRACKET ADJUSTABLE
T-VERBINDER VERSTELLBAR

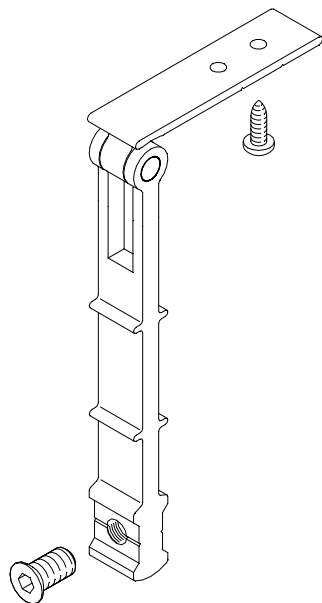

068.8786.00

T-VERBINDER VERSTELBAAR

JONCTION-T REGLABLE

T-BRACKET ADJUSTABLE

T-VERBINDER VERSTELLBAR

1 st./pc
050.5094.-

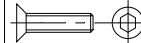

M8 x 15

1 st./pc
052.5317.-



DIN 7981
4.2 x 13

CP 155
008.3113.XX

CP 155-LS
008.3113.XX

CS 59
CS 59-HV
CS 59-Re
CS 59-So
CS 68
CS 68-HV
CS 68-Re
CS 68-So
TP 110
CS 68-FP
CS 77
CS 77-HV
TP 110-Re
CS 77-HI

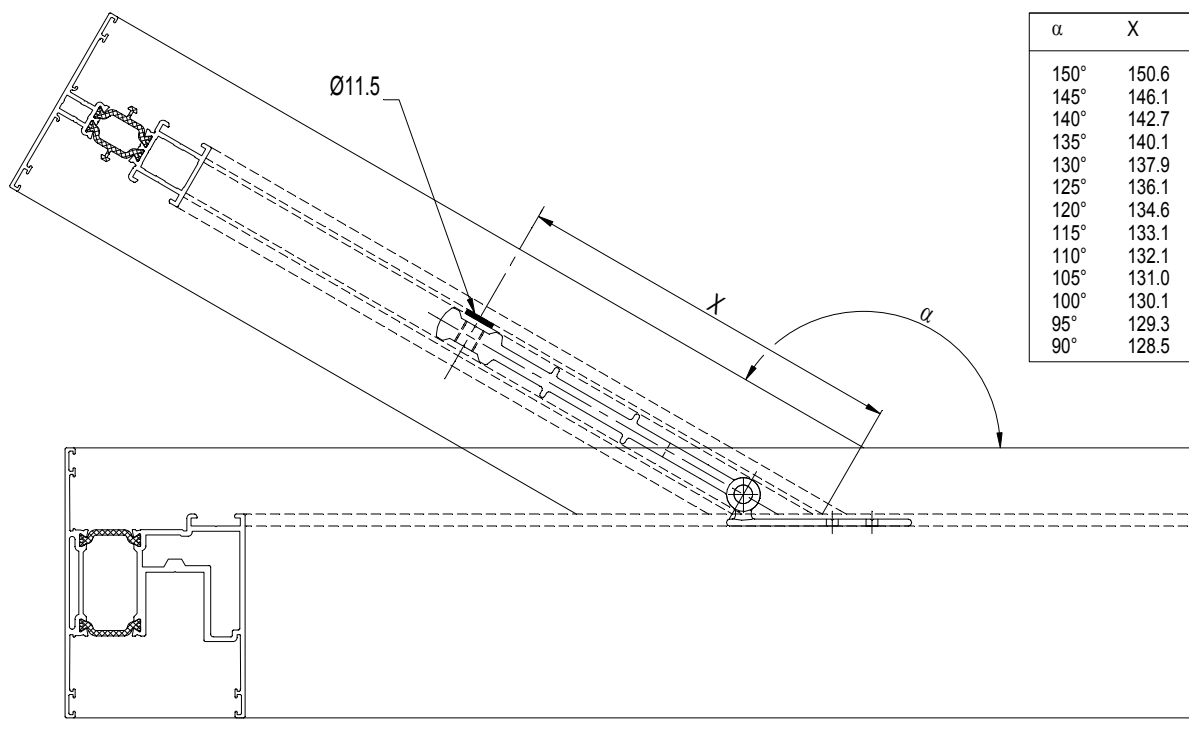

CP 155 CP 155-LS

T-VERBINDER VERSTELBAAR
JONCTION-T REGLABLE
T-BRACKET ADJUSTABLE
T-VERBINDER VERSTELLBAR

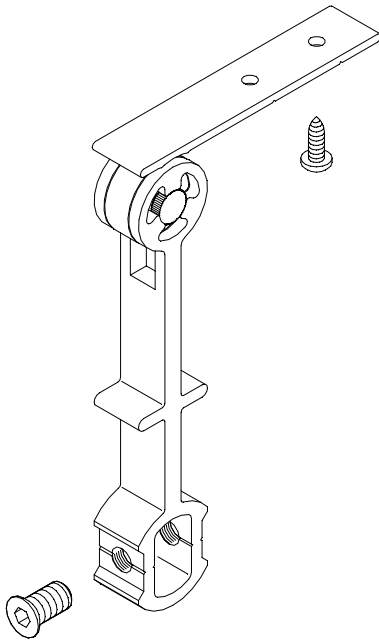

068.8787.00

T-VERBINDER VERSTELBAAR

JONCTION-T REGLABLE

T-BRACKET ADJUSTABLE

T-VERBINDER VERSTELLBAR

CP 155
008.3120.XX
008.3824.XX
0K8.3824.XX

CS 77
CS 77-HV
CS 77-HI

CP 155-LS
008.3120.XX
008.3824.XX
0K8.3824.XX

CS 59
CS 59-HV
CS 59-Re
CS 59-So
CS 68
CS 68-HV
CS 68-Re
CS 68-So
TP 110
CP 68-FP

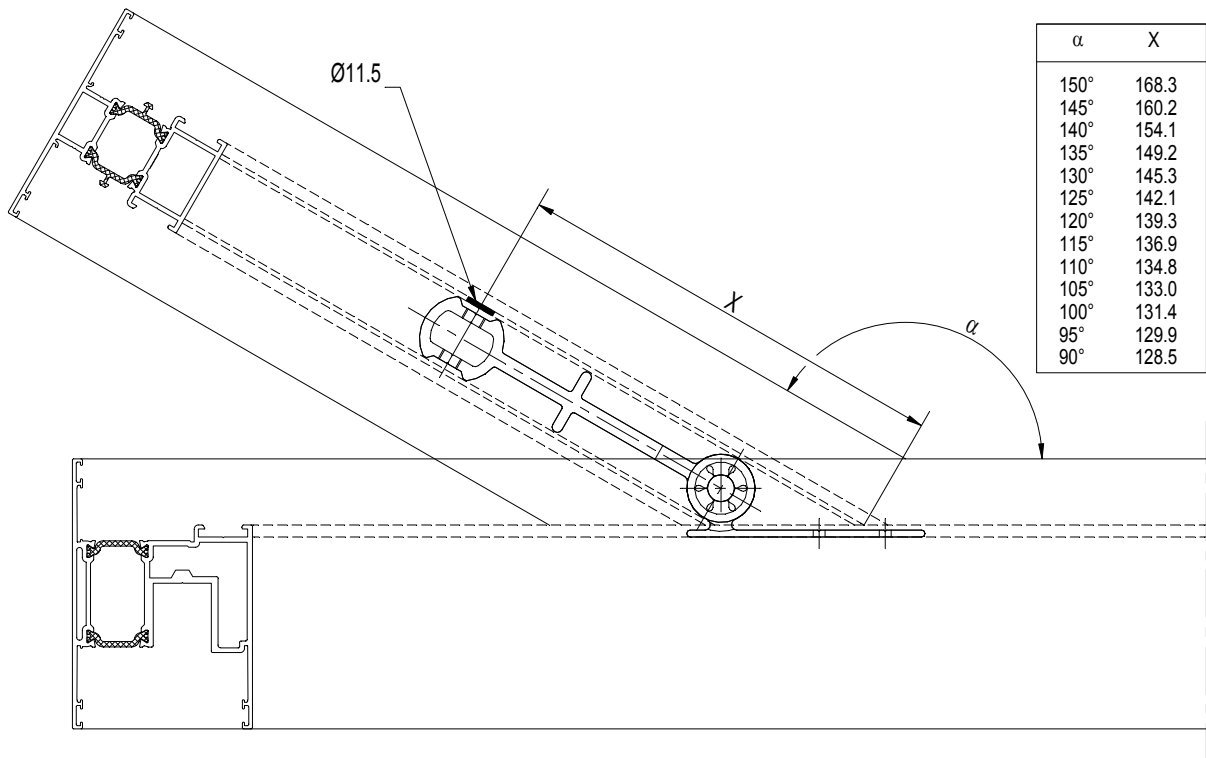
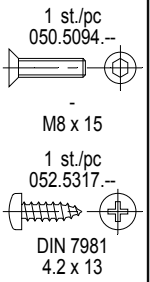

CP 155 CP 155-LS

T-VERBINDER VERSTELBAAR
JONCTION-T REGLABLE
T-BRACKET ADJUSTABLE
T-VERBINDER VERSTELLBAR



068.8788.00

T-VERBINDER VARIABEL

JONCTION-T VARIABLE

VARIABLE T-BRACKET

VARIABLELER T-VERBINDER

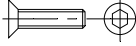
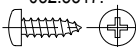
- 1 st./pc
050.5094.--

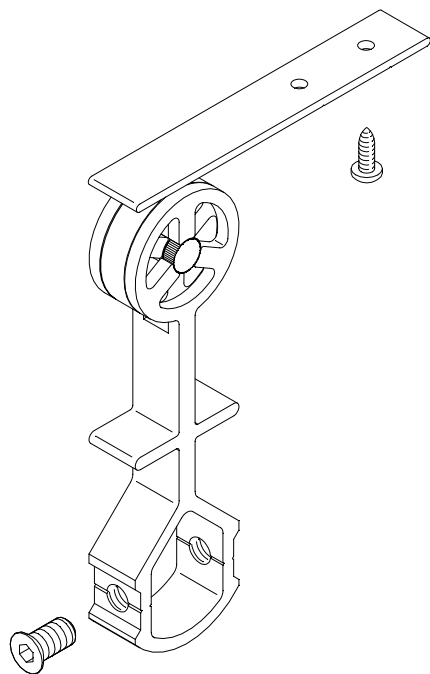
- M8 x 15
- 1 st./pc
052.5317.--

- DIN 7981
4.2 x 13





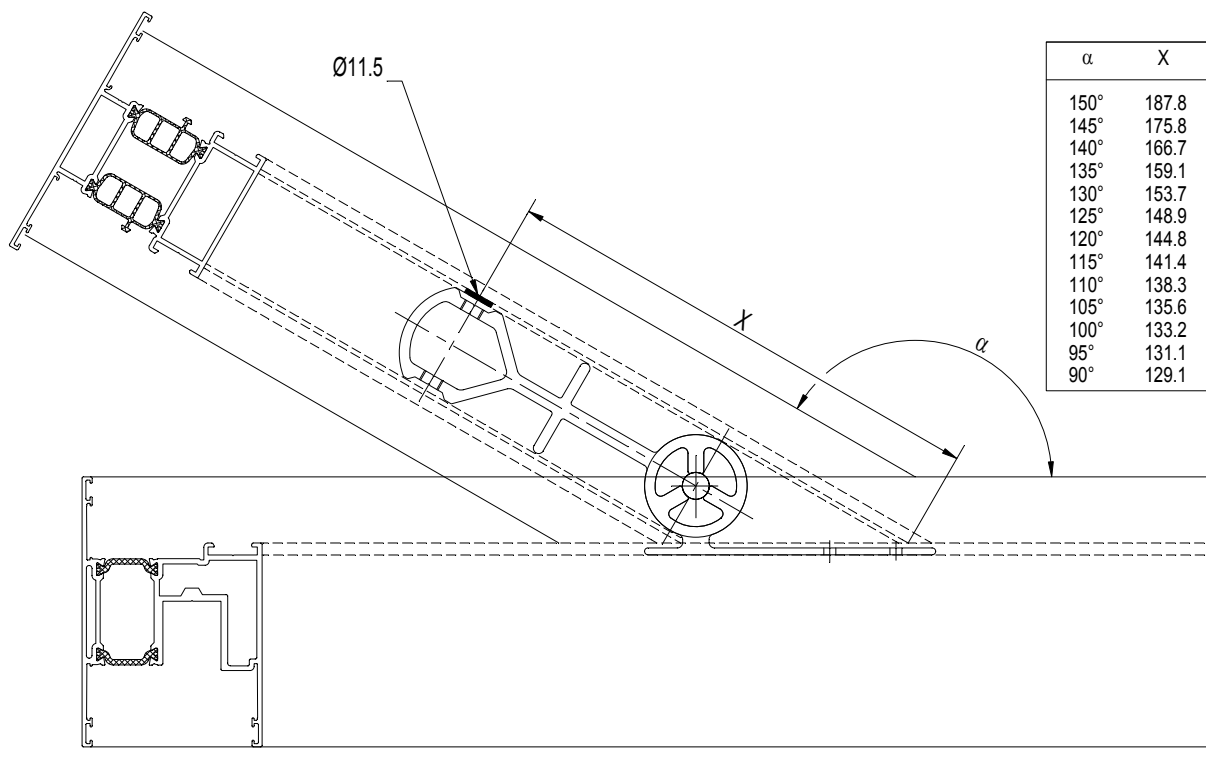



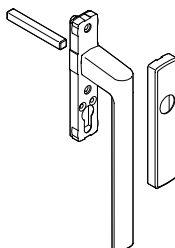

CP 155
008.3114.XX

CP 155-LS
008.3114.XX

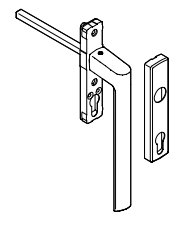
- CS 59
- CS 59-HV
- CS 68
- CS 68-HV
- TP 110
- CS 68-FP
- CS 77
- CS 77-HV
- CS 77-BP
- CS 77-HI

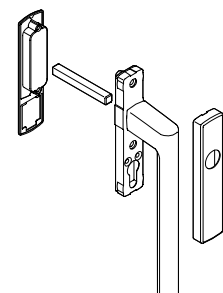

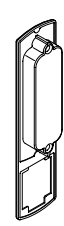

 <p>  SCREWS INCLUDED IN BASIC SET 062.6800.-- (LS 300kg) ONLY AVAILABLE IN PAINTED FINISH </p>	<p>062.7861.PA</p> <p>DEURKRUK BINNEN</p> <p>BEQUILLE INTERIEURE</p> <p>DOOR HANDLE INSIDE</p> <p>TUERDRUECKER INNEN</p>	<p>CP 96-LS</p> <p>TLS 110 CP 155-LS CP 96-LS/AP</p>		
 <p>  SCREWS INCLUDED IN BASIC SET 062.6800.-- (LS 300kg) ONLY AVAILABLE IN PAINTED FINISH </p>	<p>062.7862.PA</p> <p>DEURKRUK BINNEN</p> <p>BEQUILLE INTERIEURE</p> <p>DOOR HANDLE INSIDE</p> <p>TUERDRUECKER INNEN</p>	<p>CP 96-LS</p> <p>TLS 110 CP 155-LS CP 96-LS/AP</p>		
 <p>  SCREWS INCLUDED IN BASIC SET 062.6800.-- (LS 300kg) ONLY AVAILABLE IN PAINTED FINISH </p>	<p>062.7865.PA</p> <p>DEURKRUK</p> <p>BEQUILLE</p> <p>DOOR HANDLE</p> <p>TUERDRUECKER</p>	<p>TLS 110 CP 155-LS CP 96-LS CP 96-LS/AP</p>		
 <p>  SCREWS INCLUDED IN BASIC SET 062.6800.-- OR 062.6799.--(LS 300kg) ONLY AVAILABLE IN PAINTED FINISH </p>	<p>062.7872.PA</p> <p>KOMGREEP BUITEN</p> <p>POIGNEE A CUVETTE EXTERIEURE</p> <p>CUP HANDLE OUTSIDE</p> <p>SCHALENGRIFF AUSSEN</p>	<p>TLS 110 CP 155-LS CP 96-LS CP 96-LS/AP</p>		



062.7863.PA

DEURKRUK BUITEN





TLS 110
CP 155-LS
CP 96-LS
CP 96-LS/AP

BEQUILLE EXTERIEURE

DOORHANDLE OUTSIDE

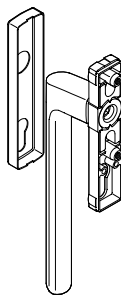
TUERDRUECKER AUSSEN



 SCREWS INCLUDED IN BASIC
SET 062.6800.-- (LS 300kg)
ONLY AVAILABLE IN PAINTED FINISH

062.7864.PA

DEURKRUK





TLS 110
CP 155-LS
CP 96-LS
CP 96-LS/AP

BEQUILLE



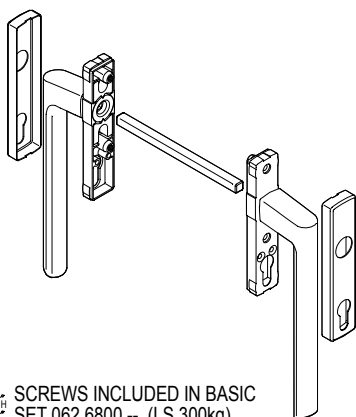



DOOR HANDLE

TUERDRUECKER

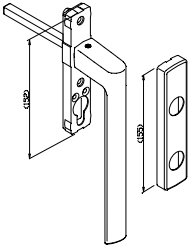

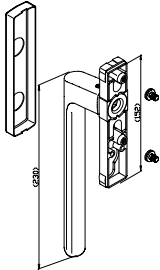
 SCREWS INCLUDED IN BASIC
SET 062.6800.-- (LS 300kg)
ONLY AVAILABLE IN PAINTED FINISH

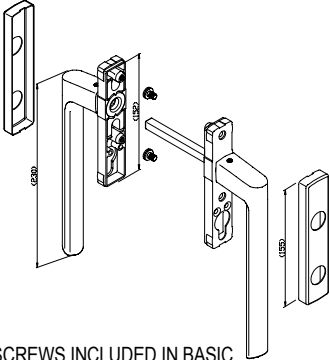

 <p>  SCREWS INCLUDED IN BASIC SET 062.6800.- (LS 300kg) ONLY AVAILABLE IN PAINTED FINISH </p>	<p>062.7963.PA</p> <p>DEURKRUK BINNEN KABA</p> <p>BEQUILLE INTERIEURE KABA</p> <p>DOOR HANDLE INSIDE KABA</p> <p>TUERDRUECKER INNEN KABA</p>	<p>TLS 110 CP 155</p>		
 <p>  SCREWS INCLUDED IN BASIC SET 062.6800.- (LS 300kg) ONLY AVAILABLE IN PAINTED FINISH </p>	<p>062.7964.PA</p> <p>DEURKRUK BUITEN KABA</p> <p>BEQUILLE EXTERIEURE KABA</p> <p>DOORHANDLE OUTSIDE KABA</p> <p>TUERDRUECKER AUSSEN KABA</p>	<p>TLS 110 CP 155</p>		
 <p>  SCREWS INCLUDED IN BASIC SET 062.6800.- (LS 300kg) ONLY AVAILABLE IN PAINTED FINISH </p>	<p>062.7965.PA</p> <p>DEURKRUK KABA</p> <p>BEQUILLE KABA</p> <p>DOOR HANDLE KABA</p> <p>TUERDRUECKER KABA</p>	<p>TLS 110 CP 155</p>		

<p>ONLY AVAILABLE IN PAINTED FINISH !062.8444.-->CP 96 !062.8429.-->CP 155</p>	<p>062.7733.PA DEURKROK BUITEN SOFTLINE</p> <p>BEQUILLE SOFTLINE EXTERIEURE SOFTLINE</p> <p>DOOR HANDLE SOFTLINE OUTSIDE SOFTLINE</p> <p>TUERDRUECKER SOFTLINE AUSSEN SOFTLINE</p>	<p>TP 110 TP 138 CP 155 CP 96 TP 110-Re</p>	<p>1 st./pc 062.8429.--</p> <p>SET -</p>
<p>ONLY AVAILABLE IN PAINTED FINISH !062.8444.-->CP 96 !062.8429.-->CP 155</p>	<p>062.8427.PA DEURKROK SOFTLINE BINNEN</p> <p>BEQUILLE SOFTLINE INTERIEURE</p> <p>DOOR HANDLE SOFTLINE INSIDE</p> <p>TUERDRUECKER SOFTLINE INNEN</p>	<p>CP 155 CP 96 CP 96-AP</p>	<p>1 st./pc 062.8429.--</p> <p>SET -</p> <p>1 st./pc 062.8444.--</p> <p>SET -</p>
<p>ONLY AVAILABLE IN PAINTED FINISH !062.8444.-->CP 96 !062.8429.-->CP 155</p>	<p>062.8428.PA DEURKROK LANGE ROZET</p> <p>BEQUILLE ROSACE ALLONGEE</p> <p>DOOR HANDLE WITH LONG COVER PLATE</p> <p>TUERDRUECKER MIT LANGSCHILD</p>	<p>CP 155 CP 96</p>	<p>1 st./pc 062.8429.--</p> <p>SET -</p>
	<p>062.8429.-- SET STIFT + SCHROEVEN M5x85MM</p> <p>SET TIGE + VIS M5x85MM</p> <p>SET SPINDLE + SCREWS M5x85MM</p> <p>SATZ STIFT + SCHRAUBEN M5x85MM</p>	<p>CP 155</p>	

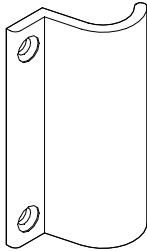

060.7090.XX

HANDGREEP

MAIN COURANTE

HANDRAIL

HANDLAUF

CS 59Pa
 CS 59
 CS 68
 TP 110
 CP 155
 MOSQUITO
 CS 77-BP
 CP 96
 CP 96-AP
 TP 110-Re

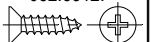
 2 st./pc
 052.5312.-

 DIN 7982
 4.2 x 13

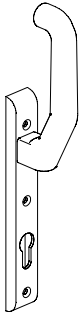
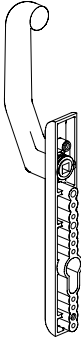
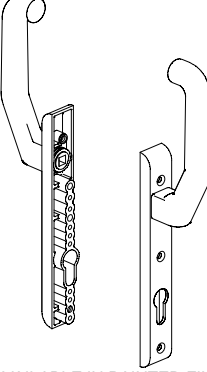
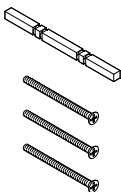

H=70
 B=22.5
 D=32 (MONORAIL)

 <p>062.8430.PA DEURKUK SOFTLINE BINNEN</p> <p>BEQUILLE SOFTLINE INTERIEURE</p> <p>DOOR HANDLE SOFTLINE INSIDE</p> <p>TUERDRUECKER SOFTLINE INNEN</p> <p><small>ONLY AVAILABLE IN PAINTED FINISH !062.8445.-->CP 96-AP !062.8433.-->CP 155-AP</small></p>	<p>062.8430.PA DEURKUK SOFTLINE BINNEN</p> <p>BEQUILLE SOFTLINE INTERIEURE</p> <p>DOOR HANDLE SOFTLINE INSIDE</p> <p>TUERDRUECKER SOFTLINE INNEN</p>	<p>CP 155-AP CP 96-AP</p>	<p>1 st./pc 062.8433.--</p> <p>SET -</p> <p>1 st./pc 062.8445.--</p> <p>SET -</p>
 <p>062.8431.PA DEURKUK SOFTLINE BUITEN</p> <p>BEQUILLE SOFTLINE EXTERIEURE</p> <p>DOOR HANDLE SOFTLINE OUTSIDE</p> <p>TUERDRUECKER SOFTLINE AUSSEN</p> <p><small>ONLY AVAILABLE IN PAINTED FINISH !062.8445.-->CP 96-AP !062.8433.-->CP 155-AP</small></p>	<p>062.8431.PA DEURKUK SOFTLINE BUITEN</p> <p>BEQUILLE SOFTLINE EXTERIEURE</p> <p>DOOR HANDLE SOFTLINE OUTSIDE</p> <p>TUERDRUECKER SOFTLINE AUSSEN</p>	<p>CP 155-AP CP 96-AP</p>	<p>1 st./pc 062.8433.--</p> <p>SET -</p> <p>1 st./pc 062.8445.--</p> <p>SET -</p>
 <p>062.8432.PA DEURKUK LANGE ROZET</p> <p>BEQUILLE ROSACE ALLONGEE</p> <p>DOOR HANDLE WITH LONG COVER PLATE</p> <p>TUERDRUECKER MIT LANGSCHILD</p> <p><small>ONLY AVAILABLE IN PAINTED FINISH !062.8445.-->CP 96-AP !062.8433.-->CP 155-AP</small></p>	<p>062.8432.PA DEURKUK LANGE ROZET</p> <p>BEQUILLE ROSACE ALLONGEE</p> <p>DOOR HANDLE WITH LONG COVER PLATE</p> <p>TUERDRUECKER MIT LANGSCHILD</p>	<p>CP 155-AP CP 96-AP</p>	<p>1 st./pc 062.8433.--</p> <p>SET -</p> <p>1 st./pc 062.8445.--</p> <p>SET -</p>
 <p>062.8433.--</p> <p>SET STIFT + SCHROEVEN M6x85MM</p> <p>SET TIGE + VIS M6x85MM</p> <p>SET SPINDLE + SCREWS M6x85MM</p> <p>SATZ STIFT + SCHRAUBEN M6x85MM</p>	<p>062.8433.--</p> <p>SET STIFT + SCHROEVEN M6x85MM</p> <p>SET TIGE + VIS M6x85MM</p> <p>SET SPINDLE + SCREWS M6x85MM</p> <p>SATZ STIFT + SCHRAUBEN M6x85MM</p>	<p>CP 155-AP</p>	

CP 155 CP 155-LS

INBRAAKWEREND
PROTECTION ANTI-VOL
BURGLAR PROTECTION
EINBRUCHHEMMEND

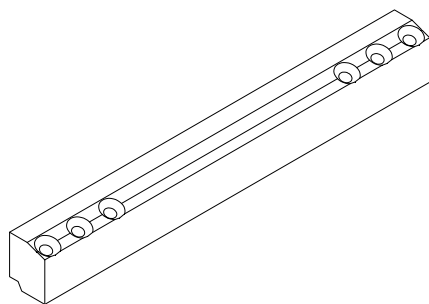

062.8424.XX

INBRAAKBEVEILIGING

PIECE D'ANTI-VOL

SECURITY DEVICE

EINBRUCHSICHERUNG

CP 155-LS
CP 155-AP
CP 155-LS/AP



062.7961.ZC

2-PUNTSLUITING
H=2170MM KABA

FERMETURE A 2 POINTS
H=2170MM KABA

2-POINT LOCK
H=2170MM KABA

2-FACHVERRIEGELUNG
H=2170MM KABA

TLS 110
CP 155

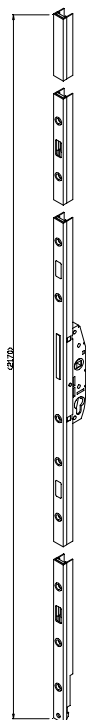

H=2170
B=22
D=52

062.7962.ZC

2-PUNTSLUITING
H=2570MM KABA

FERMETURE A 2 POINTS
H=2570MM KABA

2-POINT LOCK
H=2570MM KABA

2-FACHVERRIEGELUNG
H=2570MM KABA

TLS 110
CP 155

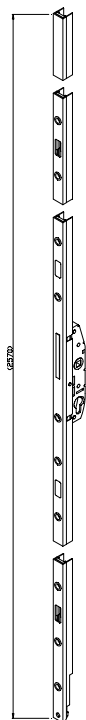

H=2570
B=22
D=52

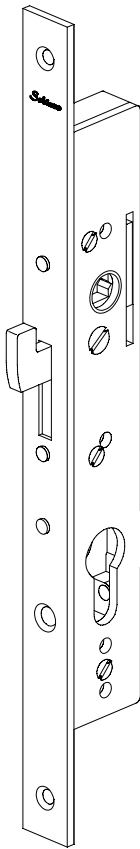

062.8425.ZC

HAAKSLOT

SERRURE A CROCHET

HOOK LOCK

HAKENSCHLOSS

CP 155



2 st./pc
052.5313.-

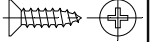

DIN 7982
4.2 x 32

062.8426.ZC

5-PUNTSLUITING

FERMETURE A 5 POINTS

5-POINT LOCK

5-FACHVERRIEGELUNG

CP 155



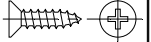





14 st./pc
052.5313.-

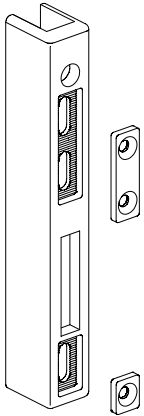

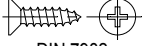
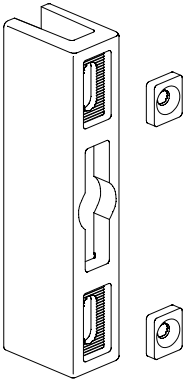
DIN 7982
4.2 x 32

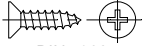

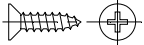

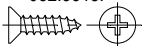
	<p>062.8434.--</p> <p>SLOTPAD H=22.5MM</p> <p>GACHE H=22.5MM</p> <p>RECEIVER H=22.5MM</p> <p>SCHLIESSBLECH H=22.5MM</p>	<p>CP 155</p>	<p></p> <p>3 st./pc 052.5318.--</p>  <p>DIN 7982 4.2 x 38</p>
	<p>062.8438.--</p> <p>SLOTPAD H=26MM</p> <p>GACHE H=26MM</p> <p>RECEIVER H=26MM</p> <p>SCHLIESSBLECH H=26MM</p>	<p>CP 155</p>	<p></p> <p>2 st./pc 052.5318.--</p>  <p>DIN 7982 4.2 x 38</p>
	<p>062.8440.XX</p> <p>SLUITLAT H=23MM</p> <p>TRINGLE H=23MM</p> <p>LINK BAR H=23MM</p> <p>SCHUBSTANGE H=23MM</p>	<p>CP 155</p>	<p></p> <p>12 st./pc 052.5318.--</p>  <p>DIN 7982 4.2 x 38</p>
	<p>062.8441.XX</p> <p>SLUITLAT H=28MM</p> <p>TRINGLE H=28MM</p> <p>LINK BAR H=28MM</p> <p>SCHUBSTANGE H=28MM</p>	<p>CP 155</p>	<p></p> <p>12 st./pc 052.5318.--</p>  <p>DIN 7982 4.2 x 38</p>

CP 155 CP 155-LS

CILINDER
CYLINDRE
CYLINDER
ZYLINDER

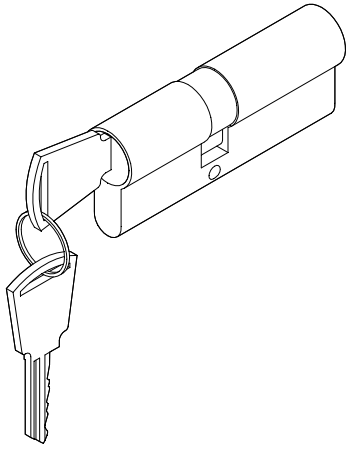

061.7038.--

CILINDER
95MM A=40 B=55

CYLINDRE
95MM A=40 B=55

CYLINDER
95MM A=40 B=55

ZYLINDER
95MM A=40 B=55

CP 155
CP 155-LS

H=33
B=17
D=95

061.7044.--

CILINDER
70MM A=30 B=40

CYLINDRE
70MM A=30 B=40

CYLINDER
70MM A=30 B=40

ZYLINDER
70MM A=30 B=40

CS 59Pa
CS 59
CS 68
CP 155
CP 155-LS
CS 77
Eco system

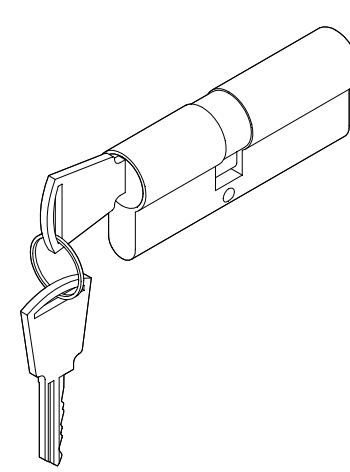



062.7869.--

BIJKOMEND SLOTPAD

CP 155-LS
CP 155-LS/AP

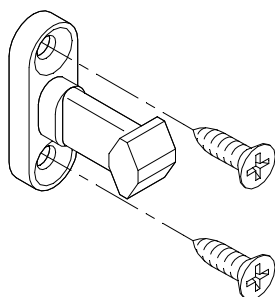

GACHE SUPPLEMENTAIRE

SUPPLEMENTARY RECEIVER

ZUSAETZLICHES SCHLIESSBLECH

062.7871.--

SET TOEBEHOREN 4-SLAG

CP 155-LS

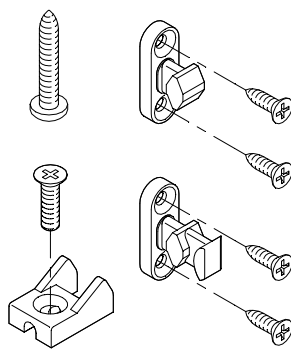

SET ACCESSOIRES 4 VANTAUX

ACCESSORIES SET 4 DOORS

SATZ ZUBEHOER 4 TUERFLUEGEL

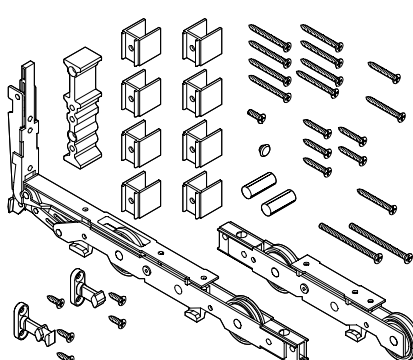

	<p>062.7867.-- BASISSET HEFSCHUIFDEUR FG=MAX.300KG</p> <p>SET DE BASE SOULEV. COULISSANT FG=MAX.300KG</p> <p>BASIC SET LIFT AND SLIDING DOOR FG=MAX.300KG</p> <p>GRUNDKARTON HEBESCHIEBETUER FG=MAX.300KG</p> <p>CP 155-LS</p>
---	--

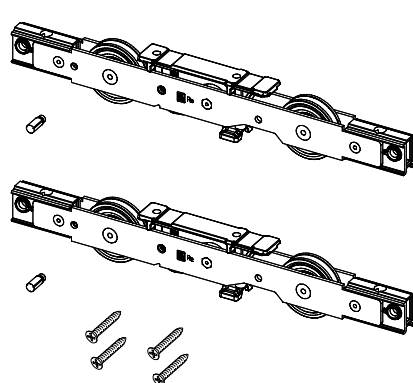
	<p>062.7903.-- LOOPWAGEN FG=MIN.300KG-MAX.400KG</p> <p>ROULETTES FG=MIN.300KG-MAX.400KG</p> <p>ROLLERS FG=MIN.300KG-MAX.400KG</p> <p>LAUFWAGEN FG=MIN.300KG-MAX.400KG</p> <p>CP 155-LS</p>
---	--



062.7868.ZC

2-PUNTSLUITING
 H=2570MM

FERMETURE A 2 POINTS
 H=2570MM

2-POINT LOCK
 H=2570MM

2-FACHVERRIEGELUNG
 H=2570MM



CP 155
 006.0340.XX

CP 155-LS
 006.0340.XX

CP 96-LS
 CP 96-LS/AP

TLS 110



1 st./pc
 050.5503.--



SET

-



1 st./pc
 050.5504.--



SET

-

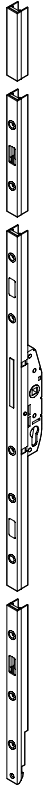

H=2570 (LS 300kg)
 ! 050.5503.-- -->CP 96-LS/AP
 ! 050.5504.-- -->CP 96-LS

062.7902.ZC

2-PUNTSLUITING
 H=2170MM

FERMETURE A 2 POINTS
 H=2170MM

2-POINT LOCK
 H=2170MM

2-FACHVERRIEGELUNG
 H=2170MM



CP 155
 006.0340.XX

CP 155-LS
 006.0340.XX

CP 96-LS
 CP 96-LS/AP

TLS 110



1 st./pc
 050.5503.--



SET

-



1 st./pc
 050.5504.--



SET

-

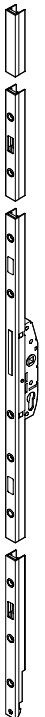

H=2170 (LS 300kg)
 ! 050.5503.-- -->CP 96-LS/AP
 ! 050.5504.-- -->CP 96-LS

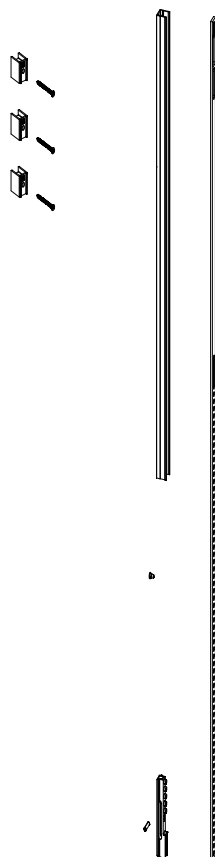

062.7937.--

VERLENGSTUK SLOT

RALLONGE SERRURE

LOCK EXTENSION

HAKENSCHLOSSVERLAENGERUNG

CP 155-LS

CP 155 CP 155-LS

GLASSTEUN
SUPPORT CALE DE VITRAGE
GLASS SUPPORT
GLASAUFLAGEPROFIL

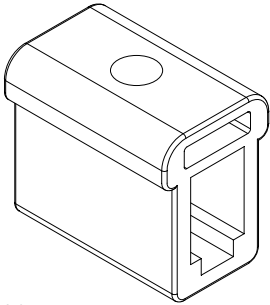
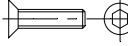
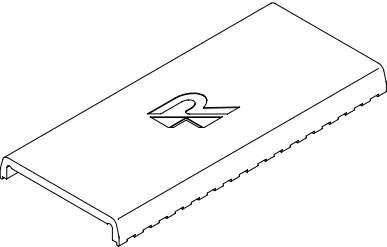
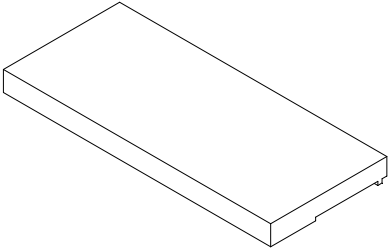

 <p>H=26.9 B=30.2 D=19.8</p>	<p>062.7800.04 GELEIDINGSSTUK PIECE DE GUIDAGE GUIDE BRACKET FUEHRUNGSSTUECK</p>	<p>TLS 110 CP 155-LS CP 96-LS</p>	<p>1 st./pc 050.5094.--  - M8 x 15</p>
 <p>H=8 B=44.5 D=100</p>	<p>069.8722.04 GLASSTEUN SUPPORT CALE DE VITRAGE GLASS SUPPORT GLASAUFLAGEPROFIL</p>	<p>CP 155 CP 155-LS CS 77 CS 77-BP</p>	
 <p>H=7.65 B=100 D=43.5</p>	<p>069.8724.04 GLASSTEUN FG=MIN250-MAX.400KG SUPPORT CALE DE VITRAGE FG=MIN250-MAX.400KG GLASS SUPPORT FG=MIN250-MAX.400KG GLASAUFLAGEPROFIL FG=MIN250-MAX.400KG</p>	<p>CP 155 CP 155-LS</p>	

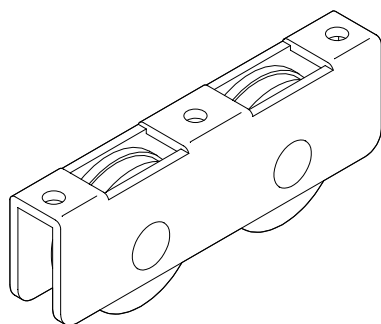

062.7834.--



DUBBEL WIEL
FG=MAX.250KG

ROULETTE DOUBLE
FG=MAX.250KG

DOUBLE ROLLER
FG=MAX.250KG

DOPPELTES LAUFRAD
FG=MAX.250KG

CP 155

 2 st./pc
 052.5372.--

 -
 6.3 x 13

CP 155 CP 155-LS

BUFFER
BUTEE
BUFFER
STOPPER

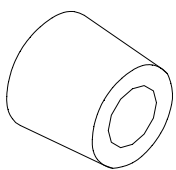
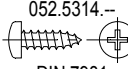
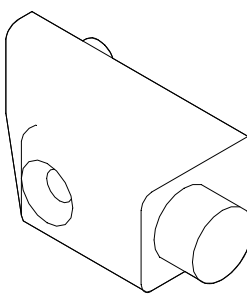
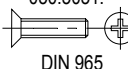
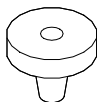
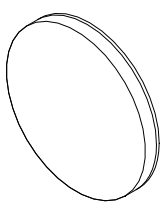



 <p>$\varnothing 16$ B=15</p>	<p>062.6744.04</p> <p>BUFFER</p> <p>BUTEE</p> <p>BUFFER</p> <p>STOPPER</p>	<p>CS 59Pa CS 59 CS 68 TP 110 TP 138 CP 155 CP 155-LS MOSQUITO CS 77 CP 96 CP 96-AP TP 110-Re</p>	<p>1 st./pc 052.5314.-</p>  <p>DIN 7981 4.2 x 50</p>
	<p>062.7715.XX</p> <p>BUFFER</p> <p>BUTEE</p> <p>BUFFER</p> <p>STOPPER</p>	<p>VISION 50 TP 110 TP 138 TLS 110 CP 155 CP 155-LS CP 45Pa TP 110-Re</p>	<p>1 st./pc 050.5051.-</p>  <p>DIN 965 M6 x 30</p>
	<p>062.7717.04</p> <p>BUFFER</p> <p>BUTEE</p> <p>BUFFER</p> <p>STOPPER</p>	<p>VISION 50 TP 110 CP 155 CP 155-LS TP 110-Re</p>	
	<p>062.7718.04</p> <p>BUFFER 1.3MM</p> <p>BUTEE 1.3MM</p> <p>BUFFER 1.3MM</p> <p>STOPPER 1.3MM</p>	<p>CP 155 CP 96 CP 96-AP</p>	

CP 155 CP 155-LS

ALGEMENE TOEBEHOREN
ACCESSOIRES GENERAUX
GENERAL ACCESSORIES
ALLGEMEINES ZUBEHOER

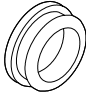

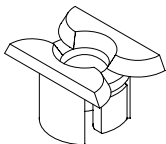
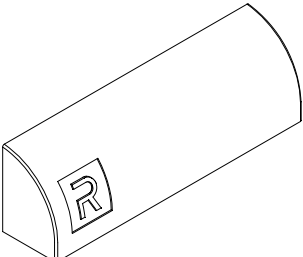
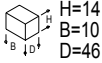
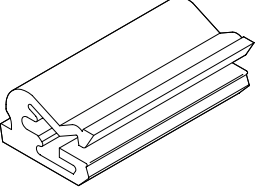
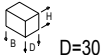
 	<p>065.6555.04</p> <p>STOP Ø10MM</p> <p>BOUHE-TROU Ø10MM</p> <p>PLUG Ø10MM</p> <p>VERSCHLUSSKAPPE Ø10MM</p>	<p>CS 59Pa CS 59 CS 68 VISION 50 TP 110 TP 138 CP 155 CP 155-LS CW 60 TR 200 MOSQUITO CR 120 CS 77 CS 77-BP CS 38-SL CS 38-SL/AP</p>	<p>PR 100</p>	
	<p>069.6747.04</p> <p>VENTIEL</p> <p>CLAPET</p> <p>VALVE CAP</p> <p>VENTILKLAPPE</p>	<p>CP 155 006.0320.XX</p> <p>CP 96-LS CP 96-AP CP 96-LS/AP</p> <p>CP 155-LS 006.0320.XX</p> <p>TP 138 TLS 110 CP 96</p>		
 	<p>069.6830.04</p> <p>AFDEKKAP WATERAFVOERSLEUVEN</p> <p>CAPUCHON DRAINAGE D'EAU</p> <p>WEEP HOLE COVER</p> <p>ABDECKKAPPE ENTWAESSERUNG</p>	<p>CP 96</p>		
 	<p>069.8422.04</p> <p>KLIPS KUNSTSTOF</p> <p>CLIP MATIERE SYNTHETIQUE</p> <p>SYNTHETIC CLIP</p> <p>KUNSTSTOFF KLEMME</p>	<p>CP 155 006.0320.XX</p> <p>CP 155-LS 006.0320.XX 006.0322.XX 006.0324.XX 006.0326.XX</p> <p>CS 59Pa CS 59 CS 59-HV CS 59-Re CS 59-So CS 68 CS 68-HV</p>	<p>CS 68-Re CS 68-So TP 110 TP 138 TLS 110 CS 77 CS 77-HV CP 45Pa TP 110-Re</p>	

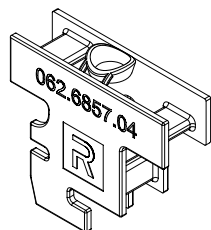

062.6857.04

AFDICHTINGSSTUK BUITENKADER

PIECE D'ETANCHEITE DORMANT

SEALING PIECE OUTERFRAME

DICHTUNGSSTUECK BLENDRAHMEN

CP 155

H=53
B=57.5
D=18

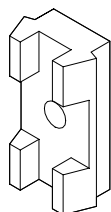

068.6351.04

KLEMSTUK

CLIP

CLIP

BEFESTIGUNGSKLOTZ

CS 59Pa
CS 59
CS 68
TP 110
TP 138
TLS 110
CP 155
CS 77

REYNASCREEN
Eco system

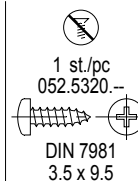

H=23
B=12
D=8

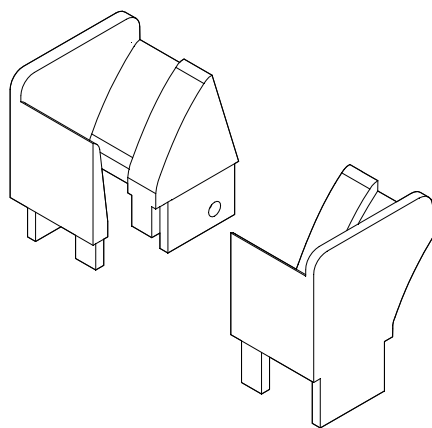

069.6761.04

INLOOPSTUK ROLLUIK

PIECE D'ENTREE VOLET

ENDS ROLLER SHUTTER

ROLLADENEINLAUF

CS 59Pa Eco system-AP
CS 59
CS 59-HV
CS 59-Re
CS 59-So
CS 68
CS 68-HV
CS 68-Re
CS 68-So
TP 110
TP 138
TLS 110
CP 155
CS 77
CS 77-HV
Eco system

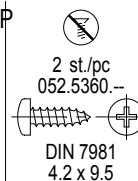

CP 155 CP 155-LS

ALGEMENE TOEBEHOREN
ACCESSOIRES GENERAUX
GENERAL ACCESSORIES
ALLGEMEINES ZUBEHOER



<p>B=60</p>	<p>062.7894.04 SET AFSTANDSTUKKEN SET PIECES D'ECARTEMENT SET DISTANCE PIECES SET DISTANZSTUECKE</p>	<p>CP 155</p>		<p>2 st./pc 052.5317... DIN 7981 4.2 x 13</p>
<p>H=12.2 B=6.4 D=15</p>	<p>062.7927.04 AFSTANDSSTUK PIECE D'ECARTEMENT DISTANCE PIECE DISTANZSTUECK</p>	<p>CP 155 CP 155-LS</p>		
<p>H=21.2 B=15 D=6.8</p>	<p>062.8045.04 AFSTANDSSTUK PIECE D'ECARTEMENT DISTANCE PIECE DISTANZSTUECK</p>	<p>CP 155</p>		
<p>Ø=14 Ø=12</p>	<p>071.6554.SY AFDEKKAP CAPUCHON FACE CAP ABDECKKAPPE</p>	<p>TP 110 TLS 110 CP 155 PR 200 TR 200 CR 120 CP 50 CP 96 CP 96-LS CP 96-AP CP 96-LS/AP TP 110-Re PR 100</p>		

CP 155 CP 155-LS

ALGEMENE TOEBEHOREN
ACCESSOIRES GENERAUX
GENERAL ACCESSORIES
ALLGEMEINES ZUBEHOER



056.6209.04

STELBLOKJE

CALE D'AJUSTEMENT

ADJUSTING BLOCK

DISTANZKLOTZ

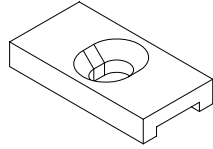

H=4
B=25
D=13

TP 110
TLS 110
CP 155
CP 155-LS
TP 110-AP
CP 155-AP
CP 155-LS/AP
CP 50
CP 96
CP 45Pa
CP 96-LS
CP 96-AP
CP 96-LS/AP
TP 110-Re

062.8038.07

STEUNSTUK VASTE VLEUGEL

PIECE DE SUPPORT OUVRANT FIXE

SUPPORTING PIECE FIXED FRAME

STUETZKLOTZ FESTEN FLUEGEL

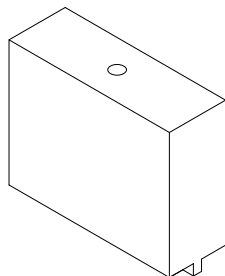

H=51
B=60
D=21

CP 155
006.1340.XX

CP 155-LS
006.1340.XX

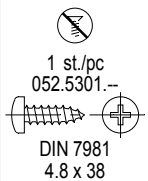

062.8039.07

STEUNSTUK VASTE VLEUGEL

PIECE DE SUPPORT OUVRANT FIXE

SUPPORTING PIECE FIXED FRAME

STUETZKLOTZ FESTEN FLUEGEL

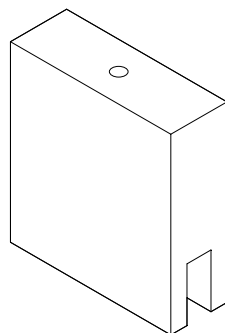

H=65
B=60
D=21



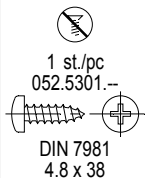

CP 155
006.1340.XX

CP 155-LS
006.1340.XX

CP 155-LS/AP

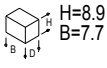

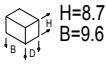

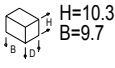
 	<p>080.9103.SY</p> <p>BINNENBEGLAZINGSDICHTING 3MM</p> <p>JOINT DE VITRAGE INTERIEUR 3MM</p> <p>INNER GLAZING GASKET 3MM</p> <p>INNENVERGLASUNGSDICHTUNG 3MM</p>	<p>CS 59Pa CS 59 CS 59-HV CS 59-Re CS 59-So CS 68 CS 68-HV CS 68-Re CS 68-So VISION 50 TP 110 TP 138 TLS 110 CP 155 CP 155-LS CW 50 CW 60 TR 200 BOREALE MOSQUITO CS 77 CS 77-HV</p>	<p>CS 59Pa-AP CS 59-AP CS 68-AP CS 77-AP CS 77-BP CS 77-FP CP 96 CP 45Pa CP 96-LS CP 96-AP CP 96-LS/AP TP 110-Re Eco system CS 38-SL Eco system-AP CS 38-SL/AP CS 24-SL</p>
 	<p>080.8904.SY</p> <p>BINNENBEGLAZINGSDICHTING 4MM</p> <p>JOINT DE VITRAGE INTERIEUR 4MM</p> <p>INNER GLAZING GASKET 4MM</p> <p>INNENVERGLASUNGSDICHTUNG 4MM</p>	<p>CS 59Pa CS 59 CS 59-HV CS 59-Re CS 59-So CS 68 CS 68-HV CS 68-Re CS 68-So VISION 50 TP 110 TP 138 TLS 110 CP 155 CP 155-LS CW 50 CW 60 TR 200 BOREALE CS 77 CS 77-HV CS 59Pa-AP</p>	<p>CS 59-AP CS 68-AP CS 77-AP CS 77-BP CS 77-FP CP 96 CP 45Pa CP 96-LS CP 96-AP CP 96-LS/AP TP 110-Re Eco system CS 38-SL Eco system-AP CS 38-SL/AP CS 24-SL</p>
 	<p>080.9105.SY</p> <p>BINNENBEGLAZINGSDICHTING 5MM</p> <p>JOINT DE VITRAGE INTERIEUR 5MM</p> <p>INNER GLAZING GASKET 5MM</p> <p>INNENVERGLASUNGSDICHTUNG 5MM</p>	<p>CS 59Pa CS 59 CS 59-HV CS 59-Re CS 59-So CS 68 CS 68-HV CS 68-Re CS 68-So VISION 50 TP 110 TP 138 TLS 110 CP 155 CP 155-LS CW 50 CW 60 TR 200 CS 77 CS 77-HV CS 59Pa-AP CS 59-AP</p>	<p>CS 68-AP CS 77-AP CS 77-BP CS 77-FP CP 96 CP 45Pa CP 96-LS CP 96-AP CP 96-LS/AP TP 110-Re Eco system CS 38-SL Eco system-AP CS 38-SL/AP CS 24-SL</p>



080.9106.SY

BINNENBEGLAZINGSDICHTING
6-7MM

JOINT DE VITRAGE INTERIEUR
6-7MM

INNER GLAZING GASKET
6-7MM

INNENVERGLASUNGSDICHTUNG
6-7MM

H=11.5
B=11.4

CS 59Pa	CS 77-AP
CS 59	CS 77-BP
CS 59-HV	CS 77-FP
CS 59-Re	CP 96
CS 59-So	CP 96-LS
CS 68	CP 96-AP
CS 68-HV	CP 96-LS/AP
CS 68-Re	TP 110-Re
CS 68-So	Eco system
VISION 50	CS 38-SL
TP 110	Eco system-AP
TP 138	CS 38-SL/AP
TLS 110	CS 24-SL
CP 155	
CW 50	
CW 60	
TR 200	
CS 77	
CS 77-HV	
CS 59Pa-AP	
CS 59-AP	
CS 68-AP	



080.9108.04

BINNENBEGLAZINGSDICHTING
8-9MM

JOINT DE VITRAGE INTERIEUR
8-9MM

INNER GLAZING GASKET
8-9MM

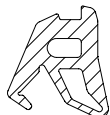





INNENVERGLASUNGSDICHTUNG
8-9MM



H=13.4
B=14.8

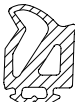

CS 59Pa	CS 77-AP
CS 59	CS 77-BP
CS 59-HV	CP 96
CS 59-Re	CP 96-LS
CS 59-So	CP 96-AP
CS 68	CP 96-LS/AP
CS 68-HV	TP 110-Re
CS 68-Re	Eco system
CS 68-So	CS 38-SL
VISION 50	Eco system-AP
TP 110	CS 38-SL/AP
TP 138	CS 24-SL
TLS 110	
CP 155	
CW 50	
CW 60	
TR 200	
CS 77	
CS 77-HV	
CS 59Pa-AP	
CS 59-AP	
CS 68-AP	



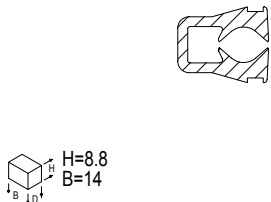

 	<p>080.9114.SY</p> <p>BUITENBEGLAZINGSDICHTING 4MM</p> <p>JOINT DE VITRAGE EXTERIEUR 4MM</p> <p>OUTER GLAZING GASKET 4MM</p> <p>AUSSENVERGLASUNGSDICHTUNG 4MM</p>	<p>CS 59Pa CS 59 CS 59-Re CS 59-So CS 68 CS 68-Re CS 68-So VISION 50 TP 110 TP 138 TLS 110 CP 155 CR 120 CS 77 CS 59-AP CS 68-AP</p>	<p>CS 77-AP CS 77-BP CS 77-FP CP 96 CP 45Pa CP 96-LS CP 96-AP CP 96-LS/AP TP 110-Re Eco system CS 38-SL Eco system-AP CS 38-SL/AP CS 24-SL CS 24-SL/AP</p>
 	<p>080.9116.04</p> <p>BUITENBEGLAZINGSDICHTING 6MM</p> <p>JOINT DE VITRAGE EXTERIEUR 6MM</p> <p>OUTER GLAZING GASKET 6MM</p> <p>AUSSENVERGLASUNGSDICHTUNG 6MM</p>	<p>CS 59Pa CS 59 CS 59-Re CS 59-So CS 68 CS 68-Re CS 68-So VISION 50 TP 110 TP 138 TLS 110 CP 155 CR 120 CS 77 CS 59-AP CS 68-AP</p>	<p>CS 77-AP CS 77-BP CP 96 CP 45Pa CP 96-LS CP 96-AP CP 96-LS/AP TP 110-Re Eco system CS 38-SL Eco system-AP CS 38-SL/AP CS 24-SL CS 24-SL/AP</p>
 	<p>080.9118.04</p> <p>BUITENBEGLAZINGSDICHTING 8MM</p> <p>JOINT DE VITRAGE EXTERIEUR 8MM</p> <p>OUTER GLAZING GASKET 8MM</p> <p>AUSSENVERGLASUNGSDICHTUNG 8MM</p>	<p>CS 59Pa CS 59 CS 59-Re CS 59-So CS 68 CS 68-Re CS 68-So VISION 50 TP 110 TP 138 TLS 110 CP 155 CR 120 CS 77 CS 59-AP CS 68-AP</p>	<p>CS 77-AP CS 77-BP CP 96 CP 96-LS CP 96-AP CP 96-LS/AP TP 110-Re Eco system CS 38-SL Eco system-AP CS 38-SL/AP</p>



	<p>080.9253.04</p> <p>RUBBER MET UITZETVOEG</p>		<p>CP 155 030.3890.XX</p>	<p>TP 110-Re Eco system Eco system-AP</p>
	<p>JOINT DE DILATATION</p> <p>EXPANSION GASKET</p> <p>DICHTUNG MIT DEHNUNGSFUEGE</p>		<p>CP 155-LS 030.3890.XX</p> <p>CS 59 CS 68 TP 110 TLS 110 CW 50 CW 60 CS 77</p>	

	<p>080.9381.04</p> <p>DICHTING Ø4MM</p> <p>JOINT Ø4MM</p> <p>GASKET Ø4MM</p> <p>DICHTUNG Ø4MM</p>		<p>CS 59 CW 50 CW 50-HI CW 50-HL CW 50-RA CW 60 CW 50-SC CW 50-SG CW 60-SG CW 50-SL Eco system Eco system-AP</p>	<p>TP 110 TP 138 TLS 110 CP 155 CP 155-LS PR 200 TR 200 BOREALE CR 120 CS 77 CW 86 CS 77-HV</p>
	<p>CS 24-SL REYNASCREEN CW 60-SC CW 60-HI CW 60-HL CS 24-SL/AP</p> <p>CS 59Pa CS 59-HV CS 59-Re CS 59-So CS 68 CS 68-HV CS 68-Re CS 68-So VISION 50</p>		<p>CS 96 CW 86-EF CP 96-LS TP 110-Re CS 38-SL CS 38-SL/AP PR 100</p>	

	<p>080.9424.04</p> <p>DICHTING EPDM</p> <p>JOINT EPDM</p> <p>GASKET EPDM</p> <p>DICHTUNG EPDM</p>		<p>CP 155 CP 155-LS</p>	

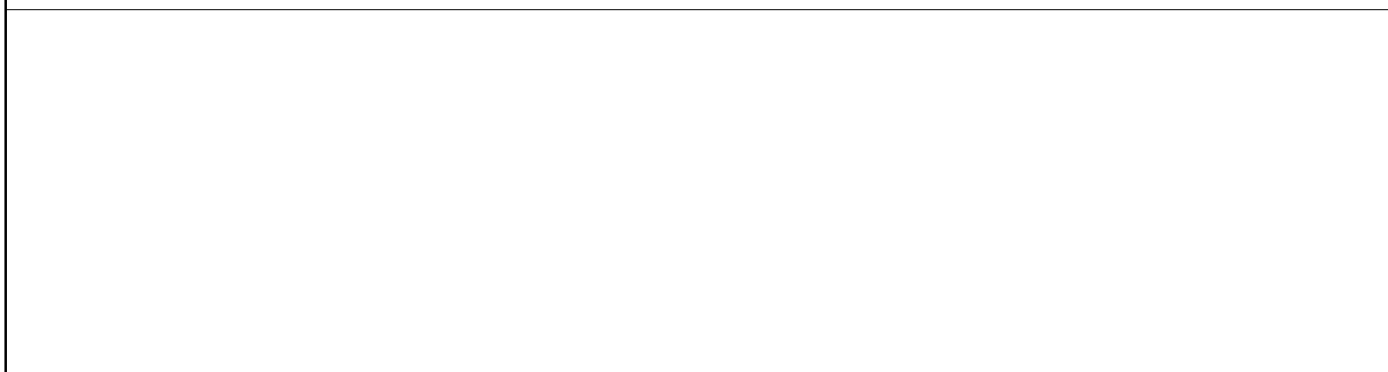



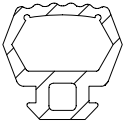
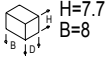
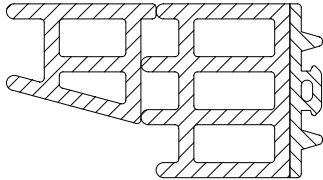
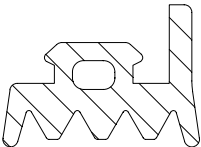
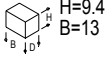



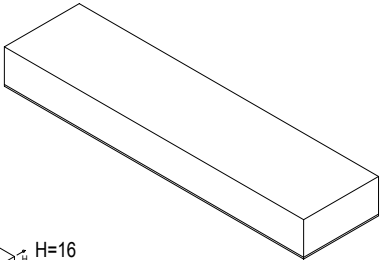
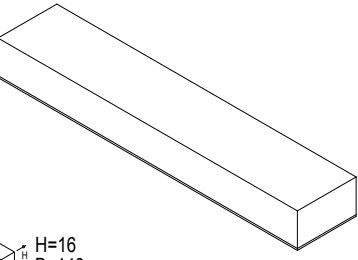
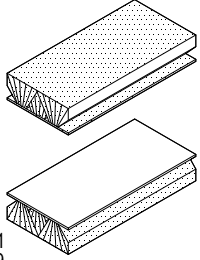

 	<p>080.9430.04 AANSLAGDICHTING</p> <p>JOINT DE BUTEE</p> <p>BUTT STRIP</p> <p>ANSCHLAGDICHTUNG</p>	<p>TP 110 CW 50 CW 60 PR 200 TR 200 CR 120 CP 96-LS CP 96-LS/AP TP 110-Re Eco system Eco system-AP</p> <p>CP 155 CP 155-LS</p>		
	<p>080.9439.04 ISOLATOR</p> <p>ISOLATEUR</p> <p>INSULATOR</p> <p>ISOLATOR</p>	<p>CP 155 CP 155-LS CP 155-AP CP 155-LS/AP</p>		
 	<p>080.9815.SY BEGLAZINGSDICHTING 3.5MM</p> <p>JOINT DE VITRAGE 3.5MM</p> <p>GLAZING GASKET 3.5MM</p> <p>VERGLASUNGSDICHTUNG 3.5MM</p>	<p>CW 60 CW 60-SG CW 60-SC CW 60-HI CW 60-HL</p> <p>TP 110 TP 138 CP 155 CP 155-LS CW 50 CW 50-HL CW 50-RA CW 50-SG CW 50-SL CP 96</p>	<p>CP 96-AP</p>	

CP 155 CP 155-LS

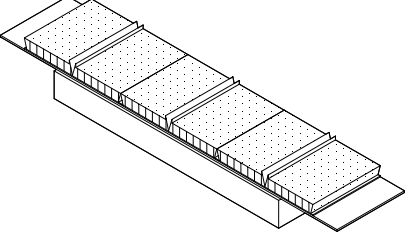
AFDICHTINGEN
FERMETURES
END PIECES
ABDICHTUNGEN

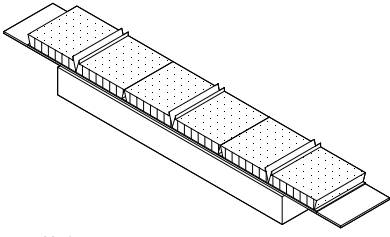

 <p>H=16 B=140 D=35</p>	<p>062.8011.04 AFDICHTING WISSELPROFIEL ONDER FERMETURE CHICANE EN BAS CLOSER MEETING SECTION BOTTOM ABDICHTUNG WECHSELPROFIL UNTEN</p>	<p>CP 155-LS</p>		
 <p>H=16 B=140 D=27.5</p>	<p>062.8012.04 AFDICHTING WISSELPROFIEL ONDER FERMETURE CHICANE EN BAS CLOSER MEETING SECTION BOTTOM ABDICHTUNG WECHSELPROFIL UNTEN</p>	<p>CP 155-LS</p>		
 <p>H=11 B=29 D=50</p>	<p>062.8013.07 BORSTELDICHTING 4-SLAG JOINT-BROSSE 4 VANTAUX WOOLPILE 4 DOOR BUERSTENDICHTUNG STULPPROFIL</p>	<p>CP 155</p>		<p>2 st./pc 052.5317.-  DIN 7981 4.2 x 13</p>
 <p>H=24 B=210 D=45</p>	<p>062.8036.04 AFDICHTING WISSELPROFIEL BOVEN FERMETURE CHICANE EN HAUT CLOSER MEETING SECTION TOP ABDICHTUNG WECHSELPROFIL OBEN</p>	<p>CP 155-LS</p>		<p>2 st./pc 052.5317.-  DIN 7981 4.2 x 13</p>
 <p>H=24 B=210 D=32.5</p>	<p>062.8037.04 AFDICHTING WISSELPROFIEL BOVEN FERMETURE CHICANE EN HAUT CLOSER MEETING SECTION TOP ABDICHTUNG WECHSELPROFIL OBEN</p>	<p>CP 155-LS</p>		<p>2 st./pc 052.5317.-  DIN 7981 4.2 x 13</p>

CP 155 CP 155-LS

AFDICHTINGEN
FERMETURES
END PIECES
ABDICHTUNGEN

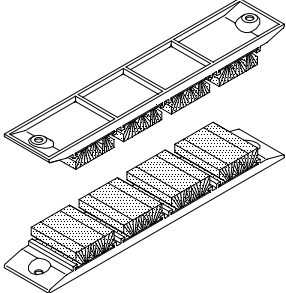
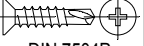
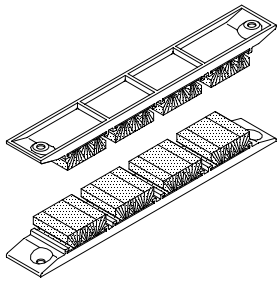
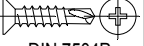
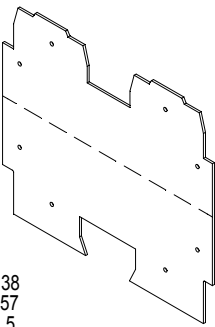
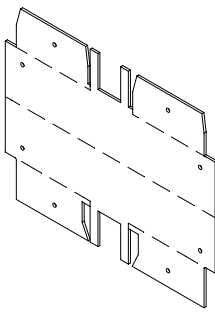
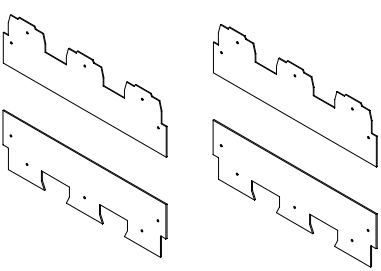

 <p>H=8.1 B=37.4 D=176</p>	<p>062.8025.04 AFDICHTING MET BORSTEL FERMETURE AVEC BROSSSE CLOSER WITH BRUSH ABDICHTUNG MIT BUERSTE</p>	<p>CP 155</p>	<p>4 st./pc 053.5403.-- DIN 7504P 4.2 x 13</p> 
 <p>H=8.1 B=30 D=176</p>	<p>062.8027.04 AFDICHTING MET BORSTEL FERMETURE AVEC BROSSSE CLOSER WITH BRUSH ABDICHTUNG MIT BUERSTE</p>	<p>CP 155</p>	<p>4 st./pc 053.5403.-- DIN 7504P 4.2 x 13</p> 
 <p>H=138 B=157 D=1.5</p>	<p>062.9396.-- AFDICHTING BUITENKADER FERMETURE DORMANT CLOSER OUTER FRAME ABDICHTUNG BLENDRAHMEN</p>	<p>CP 155 006.1300.XX CP 155-LS 006.1300.XX 006.1302.XX</p>	
 <p>H=125 B=157 D=1.5</p>	<p>062.9397.-- AFDICHTING MONORAIL FERMETURE MONORAIL CLOSER MONORAIL ABDICHTUNG MONORAIL</p>	<p>CP 155 006.0320.XX CP 155-LS 006.1322.XX</p>	
 <p>H=72.5 B=244 D=1.5</p>	<p>062.9399.04 AFDICHTING BUITENKADER FERMETURE DORMANT CLOSER OUTER FRAME ABDICHTUNG BLENDRAHMEN</p>	<p>CP 155 006.1400.XX CP 155-LS 006.1400.XX</p>	

Toebehoren
Accessoires
Accessories
Zubehör





34.G.047
02/2009

D0014040

CP 155 CP 155-LS

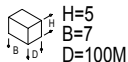
BORSTELDICHTINGEN
JOINTS-BROSSE
BRUSHES
BUERSTENDICHTUNGEN

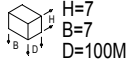

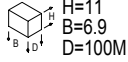
 	<p>081.9091.04 BORSTELDICHTING 5MM</p> <p>JOINT-BROSSE 5MM</p> <p>WOOLPILE 5MM</p> <p>BUERSTENDICHTUNG 5MM</p>	<p>CS 59Pa CS 59 CS 68 VISION 50 TP 110 TP 138 TLS 110 CP 155 CP 155-LS MOSQUITO CS 77 CS 77-BP CS 77-FP</p>	<p>Eco system Eco system-AP</p>	
 	<p>081.9092.04 BORSTELDICHTING 7MM</p> <p>JOINT-BROSSE 7MM</p> <p>WOOLPILE 7MM</p> <p>BUERSTENDICHTUNG 7MM</p>	<p>CS 59Pa CS 59 CS 68 VISION 50 TP 110 TP 138 TLS 110 CP 155 CP 155-LS MOSQUITO CS 77 CS 77-BP CS 77-FP</p>	<p>Eco system Eco system-AP</p>	
 	<p>081.9241.07 BORSTELDICHTING 11MM</p> <p>JOINT-BROSSE 11MM</p> <p>WOOLPILE 11MM</p> <p>BUERSTENDICHTUNG 11MM</p>	<p>CP 155</p>		

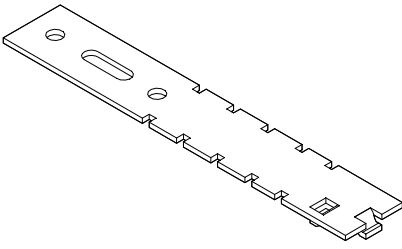
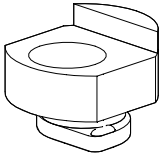
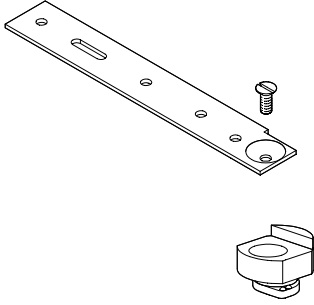
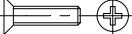
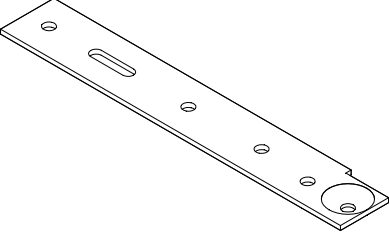

	<p>056.6297.00 INDRAAI-ANKER</p> <p>ANCRAGE A CLIPPER</p> <p>SCREW FIXING LUG</p> <p>MAUERANKER ZUM EINKLEMMEN</p>	<p>CS 59Pa CS 59 CS 59-HV CS 59-Re CS 59-So CS 68 CS 68-HV CS 68-Re CS 68-So TP 110 TLS 110 CP 155 CS 77</p>	<p>CS 77-HV CS 77-BP TP 110-Re Eco system Eco system-AP</p>	
	<p>056.6298.01 ANKERSTUK KUNSTSTOF</p> <p>PIECE D'ANCRAGE MATIERE SYNTHETIQUE</p> <p>ANCHOR PIECE SYNTHETIC</p> <p>ANKERSTUECK KUNSTSTOFF</p>	<p>CS 59Pa CS 59 CS 59-HV CS 59-Re CS 59-So CS 68 CS 68-HV CS 68-Re CS 68-So TP 110 TLS 110 CP 155 CS 77</p>	<p>CS 77-HV CS 77-BP TP 110-Re Eco system Eco system-AP</p>	
	<p>056.6299.-- ANKERBEVESTIGING GEISOLEERD</p> <p>ANCRAGE ISOLE</p> <p>INSULATED ANCHORING</p> <p>ISOLIERTE VERANKERUNG</p>	<p>CS 59Pa CS 59 CS 59-HV CS 59-Re CS 59-So CS 68 CS 68-HV CS 68-Re CS 68-So TP 110 TLS 110 CP 155 CS 77</p>	<p>CS 77-HV CS 77-BP TP 110-Re Eco system Eco system-AP</p>	<p>1 st./pc 050.5130.--</p>  <p>DIN 965 M5 x 10</p>
	<p>056.6301.-- ANKERSTUK</p> <p>BASE D'ANCRAGE</p> <p>PART ANCHOR</p> <p>EINDREHANKER</p>	<p>CS 59 CS 68 TP 110 TLS 110 CP 155 CS 77 TP 110-Re</p>		



084.9069.--

2-KOMPONENTENLIJM HOEKVERBINDER

COLLE A 2 COMPOSANTS EQUERRE

EPOXY CORNER CLEAT

2-KOMPONENTENKLEBER ECKVERBINDER

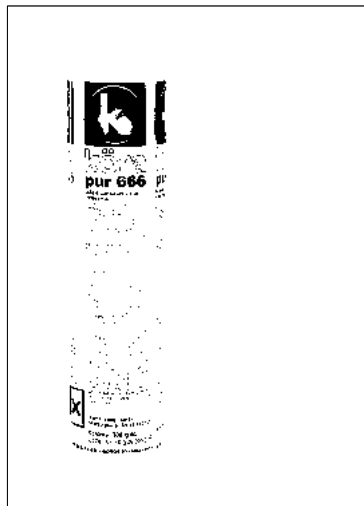

084.9103.04

VULKANISEERLIJM DICHTINGEN
310ML

COLLE VULCANISANTE JOINTS
310ML

VULCANISING GLUE GASKETS
310ML

VULKANISIERKLEBER DICHTUNGEN
310ML

 310ML

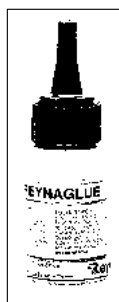

084.9105.--

SEKONDENLIJM
25G

COLLE RAPIDE
25G

CONTACT GLUE
25G

SEKUNDENLEIM
25G

 25G

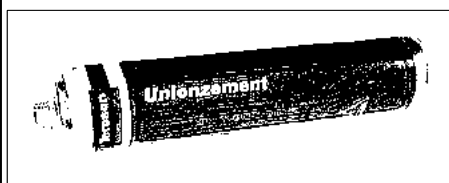

086.9182.--

DEGREASER

DEGREASER

DEGREASER

DEGREASER

 1 Liter

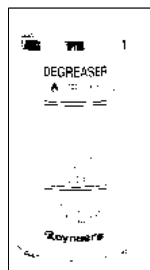

CP 155 CP 155-LS

DIVERSEN
DIVERS
MISCELLANEOUS
DIVERSE

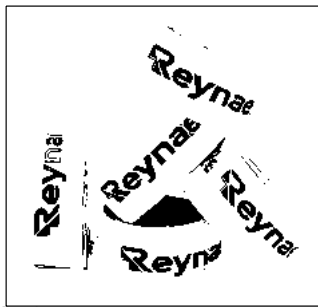

B=50

084.9111.--

KLEEFBAND POLYPROPYLEEN

CR 120
Eco system

BANDE AUTOCOLLANTE POLYPROPYLENE

TAPE SELF-ADHESIVE POLYPROPYLENE

KLEBENDES BAND POLYPROPYLEN

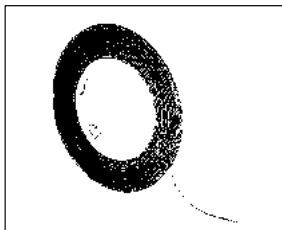

0.8 x 15
10M

084.9113.--

KLEEFBAND 2-ZIJDEN KLEVEND

CW 50
CW 60
CR 120
Eco system

BANDE 2 FACES AUTOCOLLANTES

TAPE DOUBLE SIDES SELF-ADHESIVE

KLEBENDES BAND BEIDSEITIG

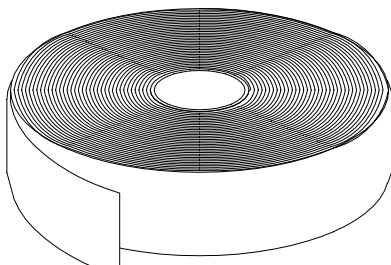

L=200M
B=50MM

084.9550.01

REYNATAPE
50MM L=200M

REYNATAPE
50MM L=200M

REYNATAPE
50MM L=200M

REYNATAPE
50MM L=200M

CP 155 CP 155-LS

DIVERSEN
DIVERS
MISCELLANEOUS
DIVERSE

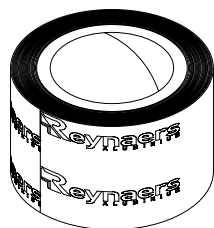

L=100M
B=80MM
Ø=150MM

084.9280.01

REYNATAPE
80MM

REYNATAPE
80MM

REYNATAPE
80MM

REYNATAPE
80MM

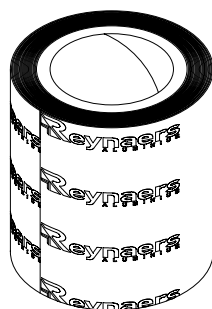

L=100M
B=150MM
Ø=150MM

084.9350.01

REYNATAPE
150MM

REYNATAPE
150MM

REYNATAPE
150MM

REYNATAPE
150MM

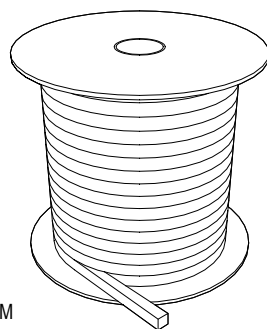

B=10MM
L=10M

084.9380.--

AFDICHTINGSBAND 1 ZIJDE ZELFKLEVENDE

JOINT D'ETANCHEITE 1 FACE AUTOCOLLANTE

SEALING TAPE 1-SIDE SELF-ADHESIVE

ABDICHTUNGSBAND EINSEITIG SELBSTKLEBEND

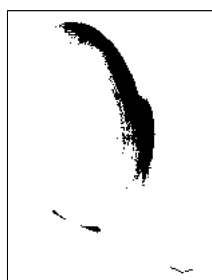

B=19MM

084.9480.--

KLEEFBAND 2-ZIJDEN KLEVENDE

BANDE 2 FACES AUTOCOLLANTES

TAPE DOUBLE SIDES SELF-ADHESIVE

KLEBENDES BAND BEIDSEITIG

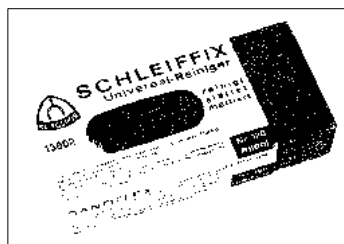

H=50
B=82
D=20

086.9150.--

ALU ERASER

ALU ERASER

ALU ERASER

ALU ERASER





CP 155 CP 155-LS

DIVERSEN
DIVERS
MISCELLANEOUS
DIVERSE



	<p>086.9160.-- INPAKPAPIER</p> <p>PAPIER CREPONE</p> <p>PACKAGING PAPER</p> <p>VERPACKUNGSPAPIER</p>	<p>CR 120 Eco system</p>		
<p>B=100MM</p>	<p>086.9175.-- SNIJMIDDEL-SPRAY 500ML</p> <p>AEROSOL D'HUILE DE COUPE 500ML</p> <p>CUTTING SPRAY 500ML</p> <p>SCHNEIDMITTEL-SPRAY 500ML</p>	<p>CR 120 Eco system</p>		
<p>500ML</p>		<p>086.9203.-- REYNACLEAN</p> <p>REYNACLEAN</p> <p>REYNACLEAN</p> <p>REYNACLEAN</p>		
<p>1L</p>		<p>086.9393.-- ELOXAL CLEANER</p> <p>ELOXAL CLEANER</p> <p>ELOXAL CLEANER</p> <p>ELOXAL CLEANER</p>	<p>CR 120</p>	
<p>1L</p>				

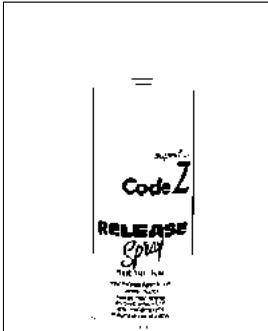
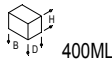
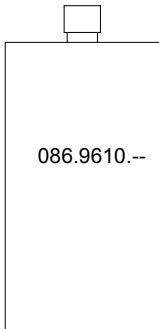

 <p>086.9204.--</p> 	<p>086.9204.-- HEAVY DUTY CLEANER</p> <p>HEAVY DUTY CLEANER</p> <p>HEAVY DUTY CLEANER</p> <p>HEAVY DUTY CLEANER</p>			
 <p>Code Z RELEASE Spray</p> 	<p>086.9551.-- SILICONE-SPRAY 400ML</p> <p>AEROSOL-SILICONE 400ML</p> <p>SILICONE SPRAY 400ML</p> <p>SILICONENSPRAY 400ML</p>			
 <p>086.9610.--</p> 	<p>086.9610.-- ANTI-CORROSIE PRODUCT</p> <p>PRODUIT ANTI-CORROSION</p> <p>CORROSION PREVENTING AGENT</p> <p>KORROSIONSSCHUTZPRODUKT</p>			

CP 155 CP 155-LS

DIVERSEN
DIVERS
MISCELLANEOUS
DIVERSE



086.9600.XX

REYNASTICK

REYNASTICK

REYNASTICK

REYNASTICK

CP 155
CP 155-LS
CR 120
Eco system



Available in .50 .51 and .53 !



086.9611.XX

REYNAPAIN
REYNAPAIN

REYNAPAIN
REYNAPAIN

REYNAPAIN
REYNAPAIN

REYNAPAIN
REYNAPAIN

CP 155
CP 155-LS
CR 120
Eco system



450ML

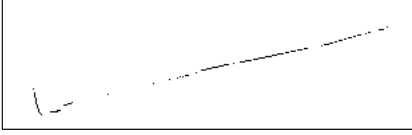

084.9061.--

MENGTUIT VOOR
084.9070.--

PIECE DE MELANGE POUR
084.9070.--

MIXING NOZZLE FOR
084.9070.--

MISCHSTUECK FUER
084.9070.--



CS 59
CS 59-HV
CS 59-Re
CS 59-So
CS 59-AD
CS 59-CD
CS 59-SD
CS 68
CS 68-HV
CS 68-Re
CS 68-So
CP 155
CP 155-LS
CW 50
CW 60
CS 68-FP
CR 120
CS 77
CS 59-AP
CS 68-AP
CS 77-AP
CS 77-BP
CS 77-HI
CS 59-PD
CS 68-PD
CS 68-FP/PD
CS 77-PD
Eco system
CS 38-SL
CS 38-SL/AP



084.9070.--

2-KOMPONENTENLIJM

COLLE A 2 COMPOSANTS

EPOXY

2-KOMPONENTENKLEBER



CS 59
CS 59-HV
CS 59-Re
CS 59-So
CS 59-AD
CS 59-CD
CS 59-SD
CS 68
CS 68-HV
CS 68-Re
CS 68-So
CP 155
CP 155-LS
CW 50
CW 60
CS 68-FP
CR 120
CS 59-AP
CS 68-AP
CS 77-AP
CS 77-BP
CS 77-FP
CS 77-HI
CS 59-PD
CS 68-PD
CS 68-FP/PD
CS 77-PD
Eco system
CS 38-SL
CS 38-SL/AP

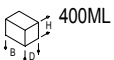

CP 155 CP 155-LS

BEVESTIGINGSMIDDELEN
MOYENS DE FIXATION
FIXINGS
BEFESTIGUNGSMITTEL

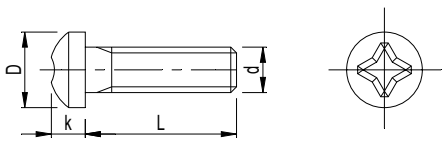
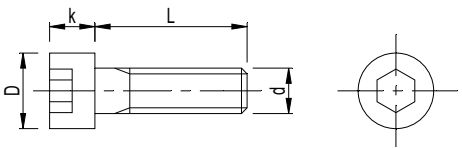

		d	afm. dimen. L	Masse dimen. k	D
	050.5010.--	M5	6	3.8	10
	050.5013.--	M5	16	3.8	10
	050.5014.--	M5	20	3.8	10
	050.5016.--	M5	12	3.8	10
	050.5019.--	M4	18	3.1	8
	050.5026.--	M5	14	3.8	10
	050.5035.--	M4	60	3.1	8
	050.5036.--	M5	100	3.8	10
	050.5037.--	M5	115	3.8	10
	050.5092.--	M4	8	3.1	8
	050.5109.--	M4	12	3.1	8
	050.5110.--	M5	8	3.8	10
	050.5111.--	M6	8	4.6	12
	050.5112.--	M6	25	4.6	12
	050.5119.--*	M5	12	3.8	10
DIN 7985					
	050.5021.--	M6	45	6	10
	050.5022.--	M6	60	6	10
	050.5023.--	M6	65	6	10
	050.5024.--	M6	70	6	10
	050.5029.--	M6	16	6	10
	050.5030.--	M6	50	6	10
	050.5031.--	M6	20	6	10
	050.5032.--	M6	30	6	10
	050.5033.--	M6	35	6	10
	050.5034.--	M6	40	6	10
	050.5071.--	M5	12	5	8.5
	050.5180.--	M6	25	6	10
	DIN 912				

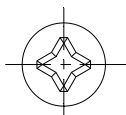
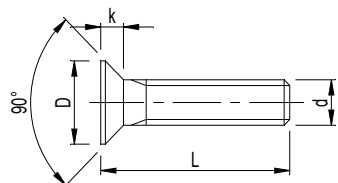

DIN 965

		d	afm. dimen. L	Masse dimen. k	D
050.5000.--	M5	10	2.5	9.2	
050.5001.--	M5	25	2.5	9.2	
050.5002.--	M4	8	2.2	7.5	
050.5003.--	M4	12	2.2	7.5	
050.5004.--	M5	60	2.5	9.2	
050.5005.--	M5	55	2.5	9.2	
050.5008.--	M5	95	2.5	9.2	
050.5009.--	M5	16	2.5	9.2	
050.5011.--	M5	20	2.5	9.2	
050.5012.--	M5	12	2.5	9.2	
050.5015.--	M5	8	2.5	9.2	
050.5017.--	M5	30	2.5	9.2	
050.5018.--	M4	16	2.2	7.5	
050.5036.--	M5	100	2.5	9.2	
050.5050.--	M6	25	3	11	
050.5051.--	M6	30	3	11	
050.5052.--	M6	35	3	11	
050.5053.--	M6	12	3	11	
050.5060.--	M6	16	4	11	
050.5075.--	M8	20	3	14.5	
050.5077.--	M4	25	2.2	7.3	
050.5078.--	M4	30	2.2	7.3	
050.5081.--	M5	45	2.5	9.2	
050.5082.--	M5	70	2.5	9.2	
050.5083.--	M5	80	2.5	9.2	
050.5084.--	M5	90	2.5	9.2	
050.5130.--	M5	10	2.5	9.2	
050.5131.--	M5	12	2.5	9.2	
050.5132.--	M5	6	2.5	11	
050.5139.--	M6	8	3	11	
050.5140.--	M6	10	3	11	
050.5141.--	M6	70	3	11	
050.5142.--	M6	80	3	9.2	
050.5161.--	M5	16	2.5	9.2	
050.5170.--	M4	10	2.2	7.5	

CP 155 CP 155-LS

BEVESTIGINGSMIDDELEN
MOYENS DE FIXATION
FIXINGS
BEFESTIGUNGSMITTEL

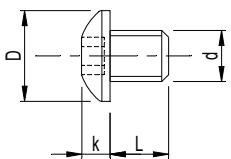
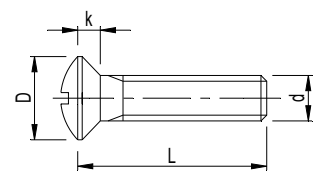
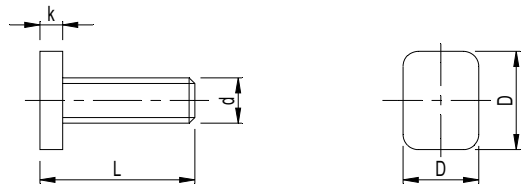
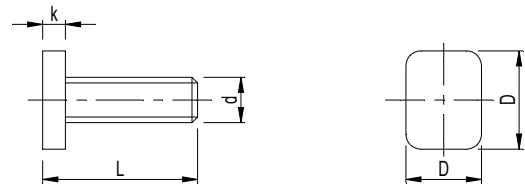
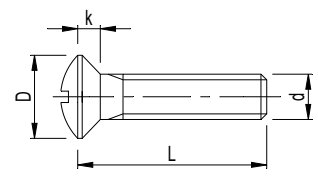
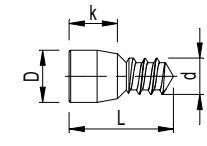

			d	afm. dimen. L	Masse dimen. k	D
 <p>ISO 7380</p>	050.5230.--		M8	10	4.4	14
 <p>DIN 966</p>	050.5191.--		M6	45	3	11
	050.5380.--		M6	16	3	10x13
 <p>DIN 931</p>	050.5389.--		M10	130	7	17
	050.5120.-- 050.5160.--		M5 M5	10 16	2.5 2.5	9.2 9.2
	050.5153.--		4.8	13.8	6.4	6.9

CP 155 CP 155-LS

BEVESTIGINGSMIDDELEN
MOYENS DE FIXATION
FIXINGS
BEFESTIGUNGSMITTEL



		d	afm. dimen. L	Masse dimen. k	D
	050.5200.--	M10	40	6.4	17
	050.5201.--	M10	80	6.4	17
	050.5203.--	M10	60	6.4	17
	050.5204.--	M10	22	6.4	17
	050.5270.--	M4	6	2.8	7
	050.5271.--	M4	10	2.8	7
	050.5390.--	M6	10	4	10
	050.5391.--	M6	20	4	10
DIN 933					

	050.5040.--	M6	10	4	
	050.5091.--	M8	10	2.4	12
	050.5093.--	M8	8	2.4	12
	050.5094.--	M8	15	2.4	12

	051.5262.--	M6	8	4	3
	051.5263.--	M6	12	4	3
	051.5264.--	M6	20	4	3
	051.5291.--	M8	8	5.5	4
	051.5292.--	M8	12	5.5	4
	051.5299.--	M12	12	8.5	6

	051.5252.--	M5	12		
	051.5262.--	M6	8		
	051.5269.--	M8	12		
	051.5270.--	M8	8		
	051.5271.--	M6	10		
	051.5272.--	M5	6		
	051.5273.--	M4	5		
	051.5274.--	M6	6		
	051.5278.--	M6	16		
	051.5279.--	M4	10	2.8	7
	DIN 914				

CP 155 CP 155-LS

BEVESTIGINGSMIDDELEN
MOYENS DE FIXATION
FIXINGS
BEFESTIGUNGSMITTEL



		d	afm. dimen. L	Masse dimen. k	D
	052.5308.--(*)	3.5	13	2.1	6.8
	052.5309.--	3.9	19	2.3	7.5
	052.5311.--	4.2	16	2.5	8.1
	052.5312.--	4.2	13	2.5	8.1
	052.5313.--	4.2	32	2.5	8.1
	052.5316.--	4.2	19	2.5	8.1
	052.5318.--	4.2	38	2.5	8.1
	052.5322.--	4.2	70	2.5	8.1
	052.5327.--	4.2	25	2.5	8.1
	052.5328.--	4.2	60	2.5	8.1
	052.5329.--	4.2	50	2.5	8.1
	052.5331.--	4.8	19	3	9.5
	052.5332.--	4.8	13	3	9.5
	052.5333.--	4.8	25	3	9.5
	052.5334.--	4.8	70	3	9.5
	052.5335.--	4.8	45	3	9.5
	052.5336.--	4.8	32	3	9.5
	052.5337.--	4.8	38	3	9.5
	052.5338.--	4.8	50	3	9.5
	052.5339.--	5.5	13	3	9.5
052.5380.--	6.3	13	3.8	12.4	
052.5381.--	6.3	38	3.8	12.4	
DIN 7982					
	052.5371.--	6.3	38	6	10
	052.5372.--	6.3	13	6	10
	052.5373.--	6.3	70	6	10

CP 155 CP 155-LS

BEVESTIGINGSMIDDELEN
MOYENS DE FIXATION
FIXINGS
BEFESTIGUNGSMITTEL

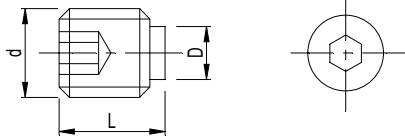
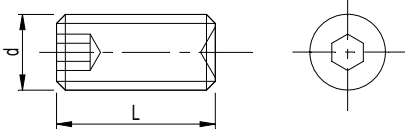
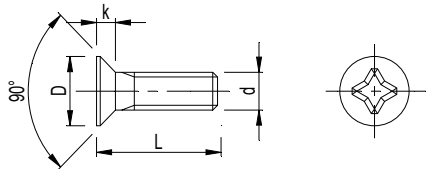
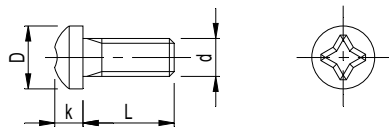
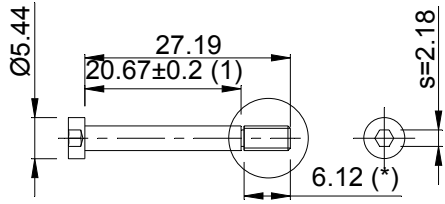
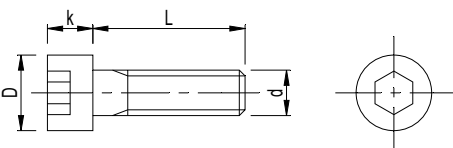

		d	afm. dimen. L	Masse dimen. k	D
 <p>DIN 915</p>	051.5254.--	M5	6		3.5
	051.5255.--	M5	12		3.5
	051.5253.--				
 <p>DIN 916</p>	051.5240.--	M5	6		
	051.5250.--	M5	10		
	051.5280.--	M5	12		
	051.5281.--	M4	10		
	051.5282.--				
	051.5290.--	M8	10		
	051.5291.--	M8	8		
 <p>DIN 965</p>	050.5009.--	M5	16	2.5	9.2
	050.5026.--				
	050.5080.-- SCHROEF MET BORGINGSVERF VIS AVEC COLLE DE BLOCAGE SCREW WITH LOCK PAINT SCHRAUBE MIT SICHERUNGSFARBE				
 <p>DIN 7985</p>	050.5117.--	M5	8	3.8	10
	050.5118.--	M5	6	3.8	10
	050.5119.-- SCHROEF MET BORGINGSVERF VIS AVEC COLLE DE BLOCAGE SCREW WITH LOCK PAINT SCHRAUBE MIT SICHERUNGSFARBE	M5	12	3.8	10
 <p>DIN 7984</p>	050.5045.--	M6	50	4	10
	050.5028.--	M6	16	6	10
	SCHROEF MET BORGINGSVERF VIS AVEC COLLE DE BLOCAGE SCREW WITH LOCK PAINT SCHRAUBE MIT SICHERUNGSFARBE				

CP 155 CP 155-LS

BEVESTIGINGSMIDDELEN
MOYENS DE FIXATION
FIXINGS
BEFESTIGUNGSMITTEL

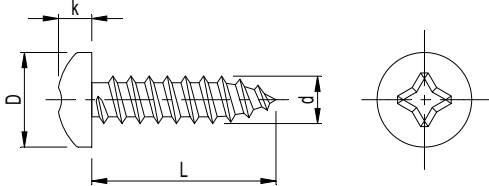
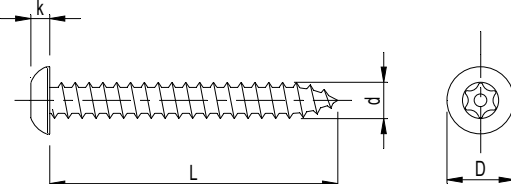
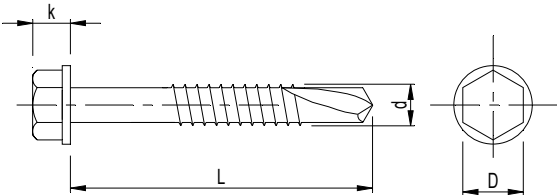

		d	afm. dimen. L	Masse dimen. k	D
	052.5200.--	3.9	19	2.8	7.5
	052.5300.--	4.8	19	3.55	9.5
	052.5301.--	4.8	38	3.55	9.5
	052.5302.--	4.8	50	3.55	9.5
	052.5304.--	4.8	90	3.55	9.5
	052.5305.--	4.8	80	3.55	9.5
	052.5310.--	4.2	16	3.05	8.2
	052.5314.--	4.2	50	3.05	8.2
	052.5315.--	4.2	25	3.05	8.2
	052.5317.--	4.2	13	3.05	8.2
	052.5320.--	3.5	9.5	2.6	6.9
	052.5321.--	4.2	32	3.05	8.2
	052.5330.--	4.8	13	3.55	9.5
	052.5340.--	5.5	45	3.95	10.8
	052.5341.--	5.5	38	3.95	10.8
	052.5342.--	5.5	32	3.95	10.8
	052.5343.--	5.5	25	3.95	10.8
	052.5344.--	5.5	13	3.95	10.8
	052.5350.--	6.3	25	4.55	12.5
	052.5351.--	6.3	38	4.55	12.5
052.5360.--	4.2	9.5	3.05	8.2	
DIN 7981					
 <p>TORX ISO 3506-1</p>	052.5400.--	4.8	38	2.5	8.9
 <p>BIMETAL DRILL IN STEEL ISO 3506</p>	053.5200.--	5.5	90	5	8

CP 155 CP 155-LS

BEVESTIGINGSMIDDELEN
MOYENS DE FIXATION
FIXINGS
BEFESTIGUNGSMITTEL



		d	afm. dimen. L	Masse dimen. k	D
<p>DIN 7504P</p>	053.5401.--	4.2	25	2.5	8.1
	053.5403.--	4.2	13	2.5	8.1
	053.5409.--	3.9	16	2.1	7.5
<p>DIN 7504N</p>	053.5402.--	4.2	38	2.5	8.1
	053.5411.--	4.8	32	3.55	9.5
	053.5412.--	4.2	19	2.5	8.1
	053.5413.--	4.8	50	3.55	9.5
	0FR.9881.--	4.8	25	3.55	9.5
<p>TORX</p>	021.5169.--	M5	11	4.8	9.7
	024.5521.--	M5	14	4.8	9.7
<p>ISO 3506</p>	053.5460.--	6.3	19	3.95	10
	053.5461.--	6.3	22	3.95	10
	053.5462.--	6.3	25	3.95	10
	053.5463.--	6.3	28	3.95	10
	053.5464.--	6.3	31	3.95	10
	053.5465.--	6.3	34	3.95	10
	053.5466.--	6.3	37	3.95	10
	053.5467.--	6.3	40	3.95	10
	053.5468.--	6.3	43	3.95	10
	053.5469.--	6.3	46	3.95	10
	053.5470.--	6.3	49	3.95	10
	053.5471.--	6.3	52	3.95	10
053.5472.--	6.3	55	3.95	10	

CP 155 CP 155-LS

BEVESTIGINGSMIDDELEN
MOYENS DE FIXATION
FIXINGS
BEFESTIGUNGSMITTEL



		d	afm. dimen. L	Masse dimen. k	D
	053.5473.--	6.3	58	3.9	10
	053.5474.--	6.3	61	3.9	10
	053.5475.--	6.3	64	3.9	10
<p>DIN 934</p>	050.5392.--	M8	5.5		13
	050.5395.--	M6	5		10
	050.5396.--	M5	4		8
	050.5400.--	M4	3.2		7
	079.5398.--	M10	8		17
<p>DIN 439</p>	050.5401.--	M10	5		17
<p>DIN 985</p>	050.5393.--	M12	12		19
	050.5394.--	M8	8		13
<p>ZESKANTMOER ZELFBORGEND ECROU HEXAGONALE AUTOBLOQUANTE HEXAGON NUT SELF-LOCKING SECHSKANTMUTTER SELBSTSICHEREND</p>					
<p>DIN 1587</p>	067.5200.--	M6	12		10
	067.5201.--	M10	18		17
	067.5202.--	M12	22		19

CP 155 CP 155-LS

BEVESTIGINGSMIDDELEN
MOYENS DE FIXATION
FIXINGS
BEFESTIGUNGSMITTEL

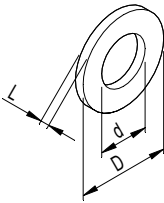
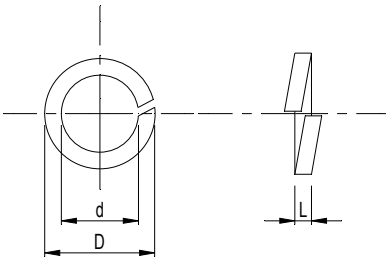
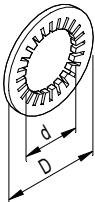
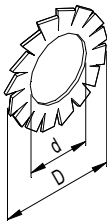
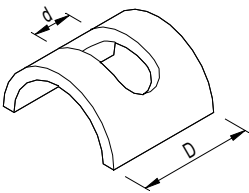
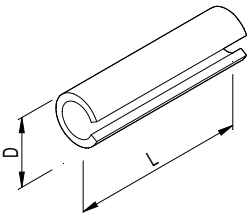

		d	afm. dimen. L	Masse dimen. k	D
 <p>DIN 125A</p>	054.5455.--	4.3	0.8		9
	054.5458.--	8.4	1.6		16
	067.5205.--	10.5	2		20
	067.5206.--	6.4	6.4		11
 <p>DIN 127B</p>	054.5450.--	10.2	2.2		18.1
 <p>DIN 6797</p>	072.5208.--	6.4			11
 <p>DIN 6798</p>	079.5206.--	10.5			18
	079.5209.--	5			14
 <p>DIN 1481</p>	058.5941.--	5	20		
	058.5944.--	4.4	26		
	058.5945.--	4.3	50		
	058.5951.--	3	24		
	065.6507.--	3.5	6		
	073.6517.--	3.5	12		

CP 155 CP 155-LS

BEVESTIGINGSMIDDELEN
MOYENS DE FIXATION
FIXINGS
BEFESTIGUNGSMITTEL

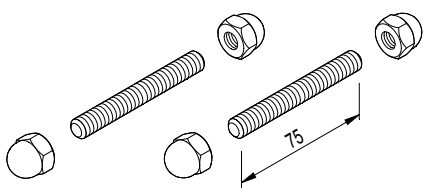
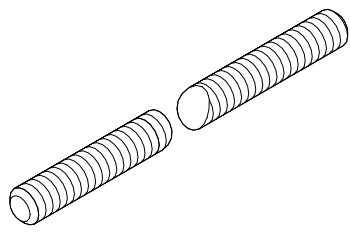
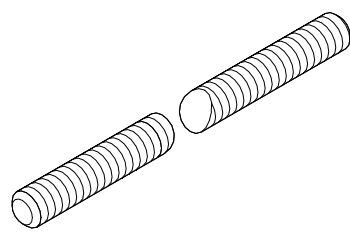

		d	afm. dimen. L	Masse dimen. k	D
	079.5212.--	M6	75		
 <p>DIN 975</p>	050.5210.-- 050.5220.--	M6 M10	1000 1000		
 <p>DIN 975 STOCK REYNAERS Ltd. ENGELAND / ANGLETERRE / ENGLAND / UNITED KINGDOM</p>	050.5214.-- 050.5215.-- 050.5216.-- 050.5221.-- 079.5222.--	M8 M10 M12 M10 M10	2000 2000 3000 45 3000		

CP 155 CP 155-LS

BEVESTIGINGSMIDDELEN
MOYENS DE FIXATION
FIXINGS
BEFESTIGUNGSMITTEL



		d	afm. dimen. L	Masse dimen. k	D
	054.5471.--	12	112		
	054.5475.--	10	80		
	054.5468.-- 054.5480.--	16 10	115 95		
	054.5469.--	12	110		
	054.5460.-- CHEMISCH ANKER M12 x 145MM ANCRAGE CHEMIQUE M12 x 145MM CHEMICAL ANCHORING M12 x 145MM CHEMISCHER ANKER M12 x 145MM				
	0FR.9883.-- 0FR.9884.-- 054.5477.--	6 6 10	90 80 60	4 4 7	10 10 17

DIN 571

CP 155 CP 155-LS

BEVESTIGINGSMIDDELEN
MOYENS DE FIXATION
FIXINGS
BEFESTIGUNGSMITTEL

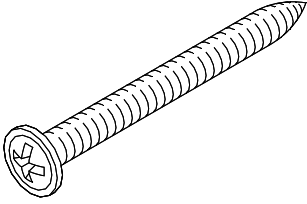
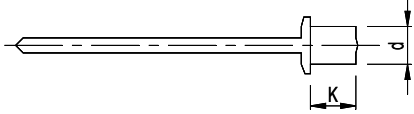
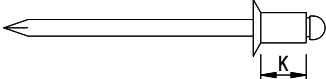
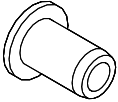
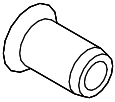
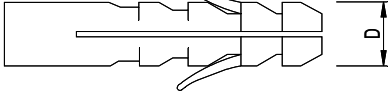

		d	afm. dimen. L	Masse dimen. k	D
 <p>THERMO PATIO 50</p>	052.5303.--	5	50		
	055.5620.-- 055.5631.-- 055.5640.-- 055.5650.-- 055.5660.--	4 3 4 4 4		6 8 8 10 15	
	055.5630.--	4		7	
	057.5710.-- 057.5720.--	M5 M6			
	057.5711.-- 057.5713.-- (200 pc) 057.5721.--	M5 M5 M6			
	054.5476.--				M6

CP 155 CP 155-LS

BEVESTIGINGSMIDDELEN
MOYENS DE FIXATION
FIXINGS
BEFESTIGUNGSMITTEL



			d	afm. dimen. L	Masse dimen. k	D
		054.5452.01	5.2	3		10
		054.5440.--	6.8	3		12.5

<p>1450<B-120<2754</p>	<p>062.6787.SY BASISSET AUTOMATISCHE HEFSCHUIFDEUR DIN L</p> <p>SET DE BASE SOULEV. COULISSANT AUTOMATIQUE DIN L</p> <p>BASIC SET AUTOMATIC LIFT AND SLIDING DOOR DIN L</p> <p>GRUNDKARTON AUTOMATISCHE HEBESCHIEBETUER DIN L</p>	<p>CP 155-LS</p>		
<p>2754<B-120<4059</p>	<p>062.6788.SY BASISSET AUTOMATISCHE HEFSCHUIFDEUR DIN L</p> <p>SET DE BASE SOULEV. COULISSANT AUTOMATIQUE DIN L</p> <p>BASIC SET AUTOMATIC LIFT AND SLIDING DOOR DIN L</p> <p>GRUNDKARTON AUTOMATISCHE HEBESCHIEBETUER DIN L</p>	<p>CP 155-LS</p>		
<p>4059<B-120<6667</p>	<p>062.6789.SY BASISSET AUTOMATISCHE HEFSCHUIFDEUR DIN L</p> <p>SET DE BASE SOULEV. COULISSANT AUTOMATIQUE DIN L</p> <p>BASIC SET AUTOMATIC LIFT AND SLIDING DOOR DIN L</p> <p>GRUNDKARTON AUTOMATISCHE HEBESCHIEBETUER DIN L</p>	<p>CP 155-LS</p>		
<p>1450<B-120<2754</p>	<p>062.6790.SY BASISSET AUTOMATISCHE HEFSCHUIFDEUR DIN R</p> <p>SET DE BASE SOULEV. COULISSANT AUTOMATIQUE DIN R</p> <p>BASIC SET AUTOMATIC LIFT AND SLIDING DOOR DIN R</p> <p>GRUNDKARTON AUTOMATISCHE HEBESCHIEBETUER DIN R</p>	<p>CP 155-LS</p>		
<p>2754<B-120<4059</p>	<p>062.6791.SY BASISSET AUTOMATISCHE HEFSCHUIFDEUR DIN R</p> <p>SET DE BASE SOULEV. COULISSANT AUTOMATIQUE DIN R</p> <p>BASIC SET AUTOMATIC LIFT AND SLIDING DOOR DIN R</p> <p>GRUNDKARTON AUTOMATISCHE HEBESCHIEBETUER DIN R</p>	<p>CP 155-LS</p>		

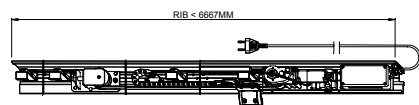

062.6792.SY

BASISSET AUTOMATISCHE HEFSCHUIFDEUR
 DIN R

CP 155-LS

SET DE BASE SOULEV. COULISSANT AUTOMATIQUE
 DIN R

BASIC SET AUTOMATIC LIFT AND SLIDING DOOR
 DIN R

GRUNDKARTON AUTOMATISCHE HEBESCHIEBETUER
 DIN R

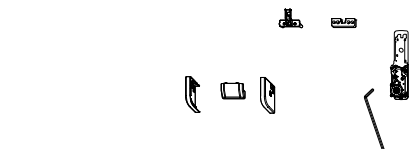

062.6793.XX

AFDEKKAP

CP 155-LS

CAPUCHON

FACE CAP

ABDECKKAPPE





	<p>086.9191.--</p>	<p>CR 120</p>
	<p>SMEERSTIFT</p>	
	<p>BROCHE DE GRAISSAGE</p>	
	<p>LUBRICATOR STICK</p>	
	<p>SCHMIERSTIFT</p>	
	<p>097.0296.00</p>	<p>CP 155-LS</p>
	<p>BOORMAL SLOT PAD</p>	<p>062.6800.--</p>
	<p>CALIBRE DE PERCAGE GACHE</p>	<p>062.7867.--</p>
	<p>BORING JIG RECIEVER</p>	<p>062.7869.--</p>
	<p>BOHRLEHRE SCHLISSBLECH</p>	<p>062.7871.--</p>
		<p>TLS 110</p>



097.0377.00

BOORMAL T-VERBINDING VARIABEL

CALIBRE DE PERCAGE RACCORDEMENT-T VARIABLE

BORING JIG T-CONNECTION ADJUSTABLE

BOHRLEHRE T-VERBINDUNG VERSTELLBAR

a	X
150	150.6
145	146.1
140	142.7
135	140.1
130	137.9
125	136.1
120	134.6
115	133.1
110	132.1
105	131.0
100	130.1
95	129.3
90	128.5

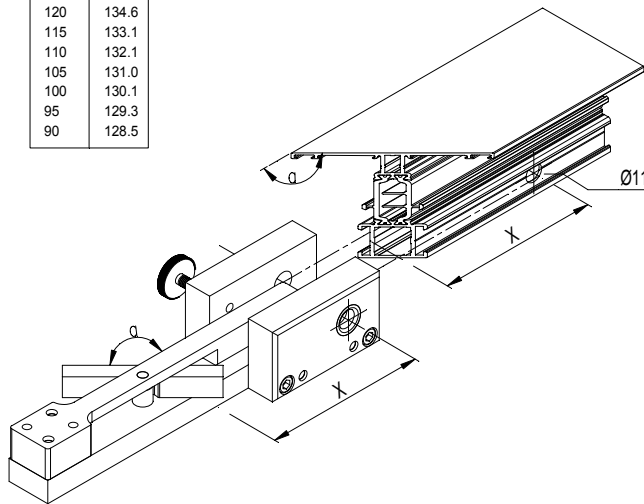

CP 155
008.3113.XX

CP 155-LS
008.3113.XX

CS 59
CS 59-HV
CS 59-Re
CS 59-So
CS 68
CS 68-HV
CS 68-Re
CS 68-So
TP 110
CS 68-FP
CS 77
CS 77-HV
TP 110-Re
Eco system
CS 86-HI
Eco system-AP

097.0378.00

BOORMAL T-VERBINDING VARIABEL

CALIBRE DE PERCAGE RACCORDEMENT-T VARIABLE

BORING JIG T-CONNECTION ADJUSTABLE

BOHRLEHRE T-VERBINDUNG VERSTELLBAR

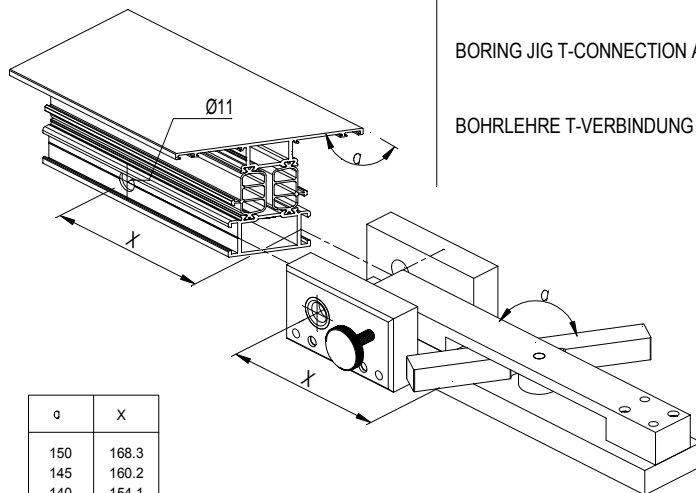

a	X
150	168.3
145	160.2
140	154.1
135	149.2
130	145.3
125	142.1
120	139.3
115	136.9
110	134.8
105	133.0
100	131.4
95	129.9
90	128.5

CP 155
008.3120.XX

CP 155-LS
008.3120.XX

CS 59
CS 59-HV
CS 59-Re
CS 59-So
CS 68
CS 68-HV
CS 68-Re
CS 68-So
TP 110
CS 68-FP
CS 77
CS 77-HV
CS 86-HI

AV 100



097.0454.00

BOORMAL T-VERBINDING VARIABEL

CALIBRE DE PERCAGE RACCORDEMENT-T VARIABLE

BORING JIG T-CONNECTION ADJUSTABLE

BOHRLEHRE T-VERBINDUNG VERSTELLBAR

CP 155
008.3114.XX

CP 155-LS
008.3114.XX

CS 59
CS 59-HV
CS 68
CS 68-HV
TP 110
CS 68-FP
CS 77
CS 77-HV
CS 77-BP
CS 77-HI

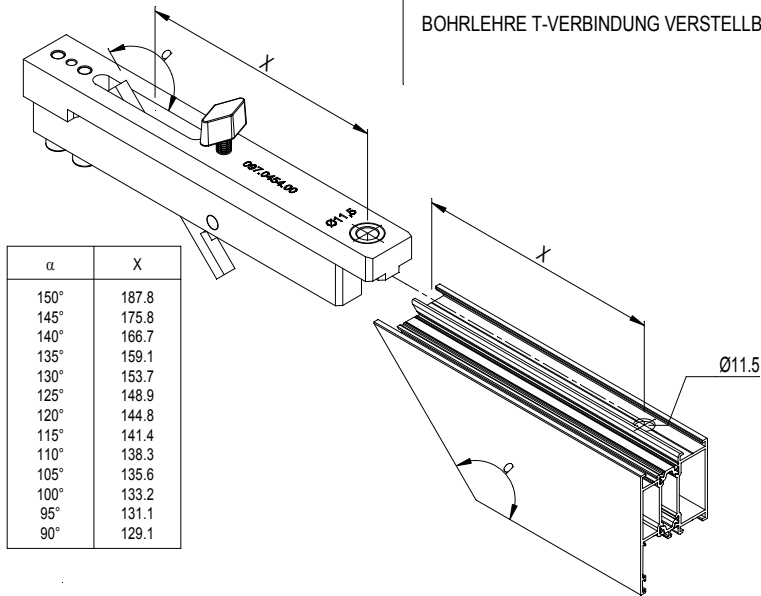



097.0393.00

BOORMAL T-VERBINDING

CALIBRE RACCORDMENT-T

BORING JIG T-CONNECTION

BOHRLEHRE T-VERBINDUNG

CS 59Pa
CS 59Pa-AD
CS 59Pa-CD
CS 59Pa-SD
CS 59
CS 59-Re
CS 59-So
CS 68
TP 110

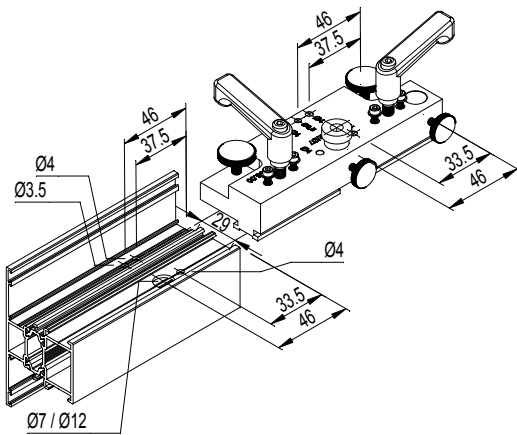

097.0410.00

BOORMAL T-VERBINDING

CALIBRE RACCORDMENT-T

BORING JIG T-CONNECTION

BOHRLEHRE T-VERBINDUNG

CP 155
006.1340.XX
008.0114.XX
008.3113.XX
008.3114.XX
008.3120.XX
008.3123.XX
008.3824.XX
0K8.3824.XX

CP 155-LS
006.1340.XX
008.3113.XX
008.3114.XX
008.3120.XX
008.3123.XX
008.3824.XX
0K8.3824.XX

CS 77
CS 77-BP
CS 77-FP
CP 155-AP
CP 155-LS/AP
CS 77-Re

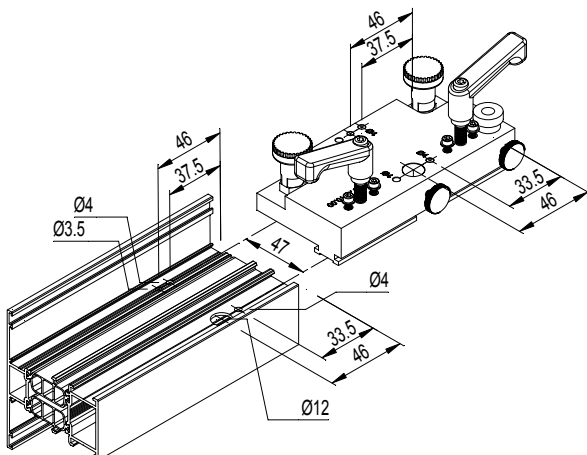

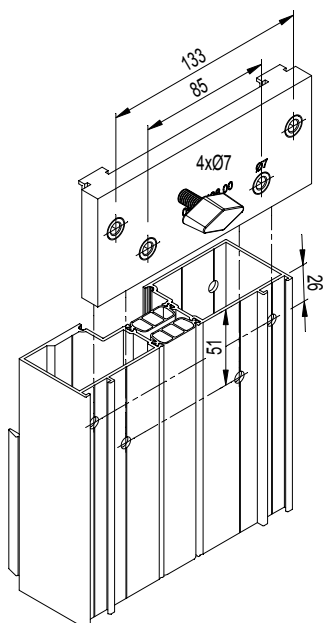

097.0436.00

BOORMAL SCHROEFVERBINDING

CALIBRE DE PERCAGE JONCTION A VISSER

BORING JIG SCREW CONNECTION

BOHRLEHRE VERSCHRAUBUNG

CP 155
006.0320.XX
006.1300.XX

CP 155-LS
006.1300.XX
006.1302.XX
006.1322.XX

CP 155-AP
CP 155-LS/AP

097.0437.00

BOORMAL ONTWATERING

CALIBRE DE PERCAGE DRAINAGE

BORING JIG DRAINAGE

BOHRLEHRE ENTWAESSERUNG

CP 155
006.0320.XX
006.1300.XX

CP 155-LS
006.0324.XX
006.0326.XX
006.1300.XX

CP 155-AP
CP 155-LS/AP

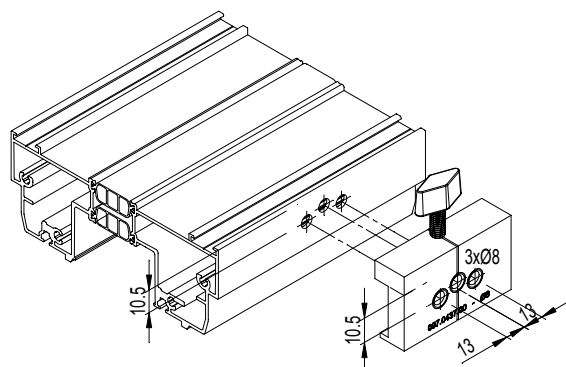

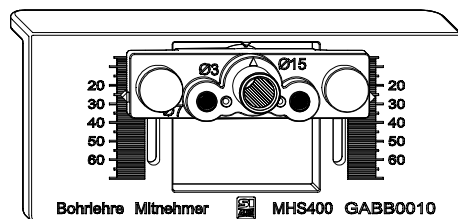

097.0683.07

BOORMAL

CALIBRE DE PERCAGE

BORING JIG

BOHRLEHRE

CP 155-LS



097.0440.00

BOORMAL SCHROEFHOEK

CALIBRE DE PERCAGE EQUERRE A VISSER

BORING JIG SCREW CORNER CLEAT

BOHRLEHRE SCHRAUBECKWINKEL

CP 155
006.0320.XX
006.1300.XX

CP 155-LS
006.1300.XX

CP 155-AP
CP 155-LS/AP

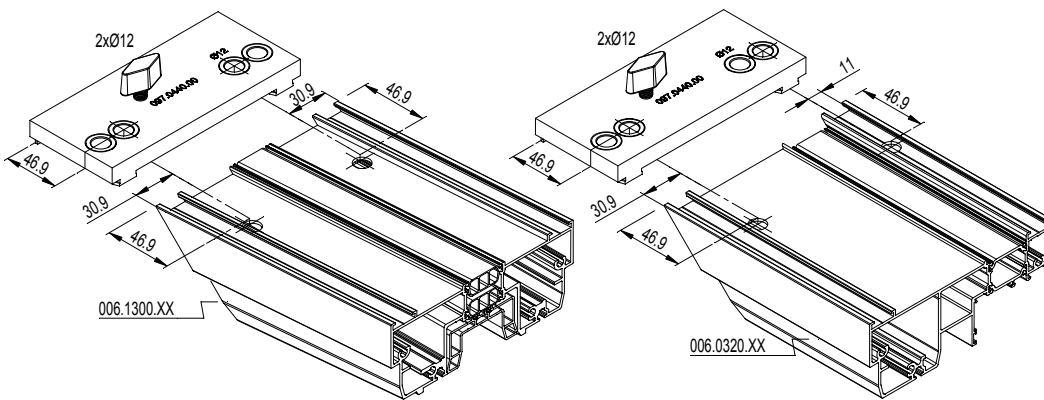

097.0441.00

BOORMAL SCHROEFHOEK

CALIBRE DE PERCAGE EQUERRE A VISSER

BORING JIG SCREW CORNER CLEAT

BOHRLEHRE SCHRAUBECKWINKEL

CP 155
006.1340.XX

CP 155-LS
006.1340.XX

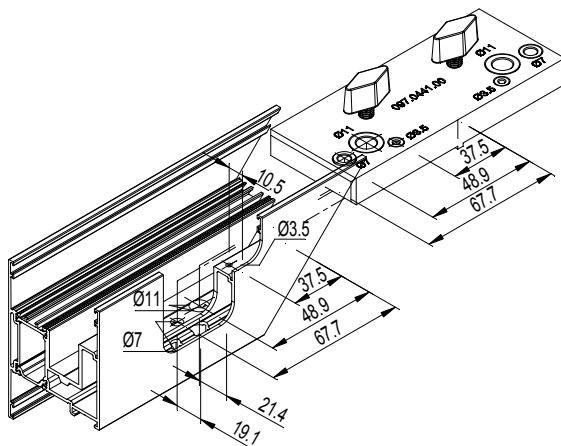



097.P100.00

PONSUNIT HOEK- EN T-VERBINDING

UNITE D'ETAMPER CONNECTION D'EQUERRE ET TRAVERSE

PUNCH UNIT CORNER AND T-CONNECTION

STANZEIHEIT ECK- UND T-VERBINDUNG

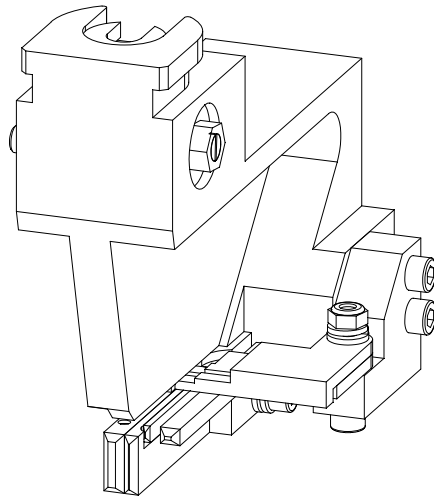

CP 155
008.3114.XX
008.3120.XX
008.3123.XX

CP 155-LS
008.3114.XX
008.3120.XX
008.3123.XX

CS 59
CS 59-HV
CS 59-Re
CS 59-So
CS 68
CS 68-HV
CS 68-Re
CS 68-So
TP 110
CS 77
CS 77-HV
CS 77-BP
CS 86-HI

097.P200.00

PONSUNIT HOEK- EN T-VERBINDING

UNITE D'ETAMPER CONNECTION D'EQUERRE ET TRAVERSE

PUNCH UNIT CORNER AND T-CONNECTION

STANZEIHEIT ECK- UND T-VERBINDUNG

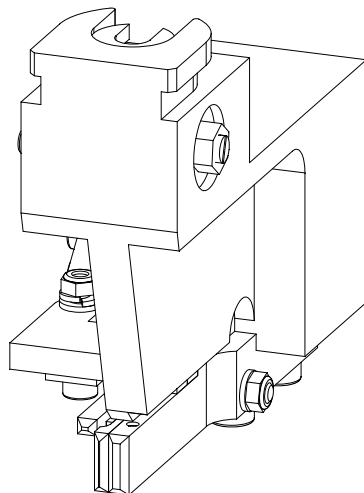

CS 68

CS 59
CS 59-HV
CS 59-Re
CS 59-So
CS 68-HV
CS 68-Re
CS 68-So
CS 68-FP
CS 77
CS 77-HV
CS 86-HI



097.P800.00

PONSUNIT T-VERBINDING

UNITE D'ETAMPER JONCTION-T

PUNCH UNIT T-BRACKET

STANZEINHEIT T-VERBINDUNG

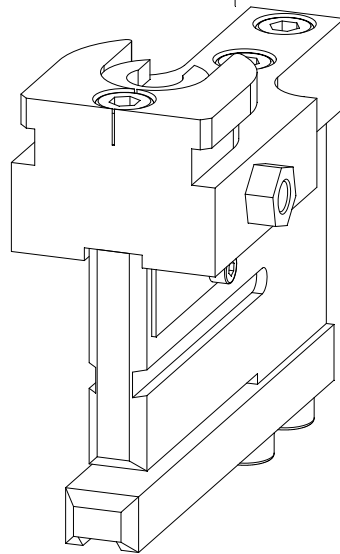

CP 155
008.3113.XX
008.3114.XX
008.3120.XX
008.3123.XX
008.3824.XX
OK8.3824.XX

CP 155-LS
008.3113.XX
008.3114.XX
008.3120.XX
008.3123.XX
008.3824.XX
OK8.3824.XX

CS 59
CS 59-HV
CS 59-Re
CS 59-So
CS 59-AD
CS 68
CS 68-HV
CS 68-Re
CS 68-So
TP 110
CW 50
CW 50-HI
CW 60
CS 68-FP
CS 77
CS 77-HV
CS 77-BP
CW 60-DRL

CS 86-HI

097.P900.00

PONSUNIT ONTWATERING

UNITE D'ETAMPER DRAINAGE

PUNCH UNIT DRAINAGE

STANZEINHEIT ENTWAESSERUNG

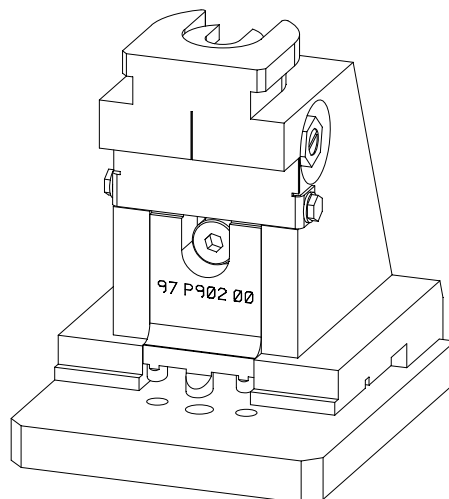

CP 155
008.3113.XX
008.3824.XX
OK8.3824.XX

CP 155-LS
008.3113.XX
008.3824.XX
OK8.3824.XX

CS 59
CS 59-HV
CS 59-AD
CS 68
CS 68-HV
TP 110
CW 60
CS 68-FP
CS 77
CS 77-HV
CS 77-BP
CS 77-FP
Eco system
CS 86-HI
Eco system-AP

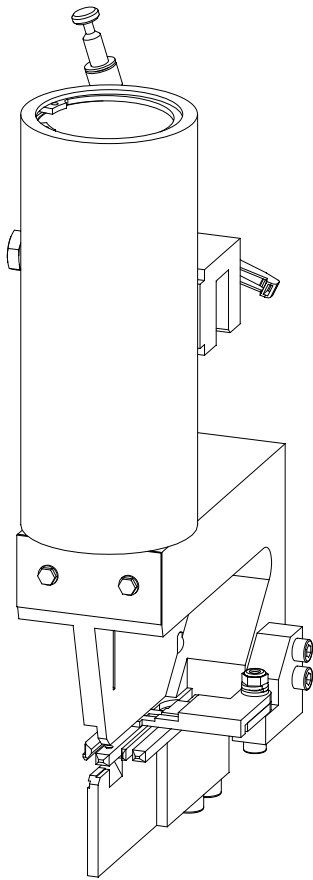

097.O900.00

PONSUNIT HOEK- EN T-VERBINDING

UNITE D'ETAMPER CONNECTION D'EQUERRE ET TRAVERSE

PUNCH UNIT CORNER AND T-CONNECTION

STANZEIHEIT ECK- UND T-VERBINDUNG



CP 155
008.3113.XX

CS 86-HI

CP 155-LS
008.3113.XX

CS 59
CS 59-HV
CS 59-Re
CS 59-So
CS 68
CS 68-HV
CS 68-Re
CS 68-So
TP 110
CS 77
CS 77-HV

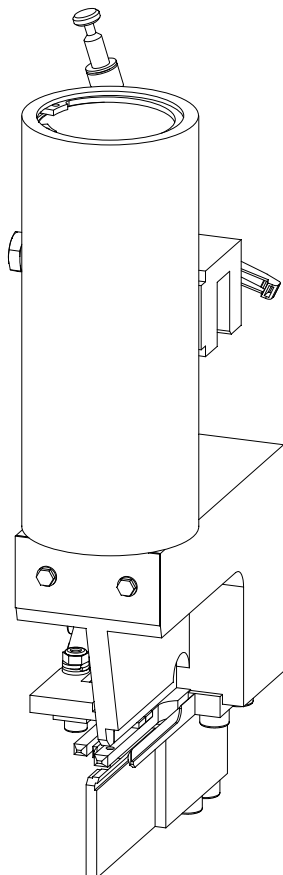

097.P000.00

PONSUNIT HOEK- EN T-VERBINDING

UNITE D'ETAMPER CONNECTION D'EQUERRE ET TRAVERSE

PUNCH UNIT CORNER AND T-CONNECTION

STANZEIHEIT ECK- UND T-VERBINDUNG



CS 59
CS 59-HV
CS 59-Re
CS 59-So
CS 68
CS 68-HV
CS 68-Re
CS 68-So
CS 77
CS 77-HV
CS 86-HI



095.B500.00

HOEKENPERS

SERTISSEUSE

CRIMPING MACHINE

ECKVERBINDUNGSMASCHINE

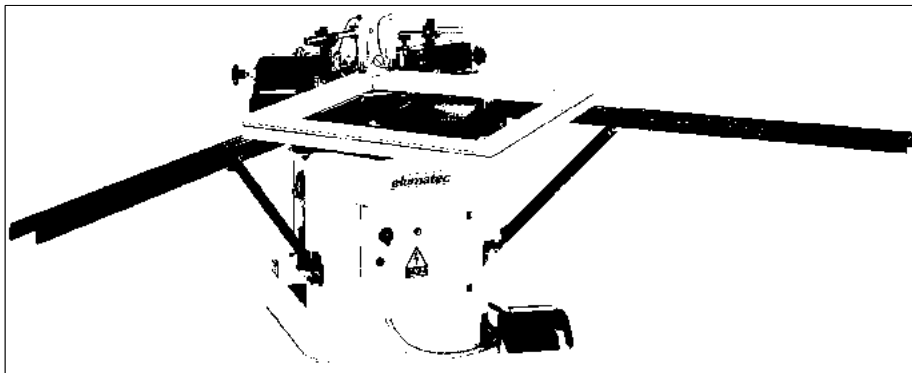

- | | |
|---|--|
| CP 155
006.0320.XX
006.1300.XX
006.1340.XX
008.3113.XX
008.3114.XX
008.3120.XX
008.3123.XX

CP 155-LS
006.1300.XX
006.1340.XX
008.3113.XX
008.3114.XX
008.3120.XX
008.3123.XX

PS 50-SP
CS 59Pa
CS 59Pa-AD
CS 59Pa-CD
CS 59Pa-SD
CS 59
CS 59-HV
CS 59-Re
CS 59-So
CS 59-CD
CS 59-SD
CS 68
CS 68-HV
CS 68-Re
CS 68-So
TP 110
TP 138
TLS 110
CW 50
CW 50-HI
CW 50-HL
CW 60
TR 200
MOSQUITO
CS 68-FP
CR 120
CS 77
CW 86
CS 77-HV
CS 77-BP
CW 50-SC
CW 50-SG
CS 77-FP
CP 155-AP
CP 155-LS/AP
CP 96
CW 60-DRL
CP 45Pa
CW 86-EF
CP 96-LS
CP 96-AP
CP 96-LS/AP
TP 110-Re
CS 68 Optima
Eco system
CS 38-SL
CS 86-HI
Eco system-AP
CS 38-SL/AP
CS 24-SL
CW 60-SC
CS 24-SL/AP | CW 86-EF/Hi
CS 77-Re
Eco System Optima |
|---|--|

CP 155 CP 155-LS

MACHINES EN TOEBEHOREN
MACHINES ET ACCESSOIRES
MACHINERY AND ACCESSORIES
MASCHINEN UND ZUBEHOER

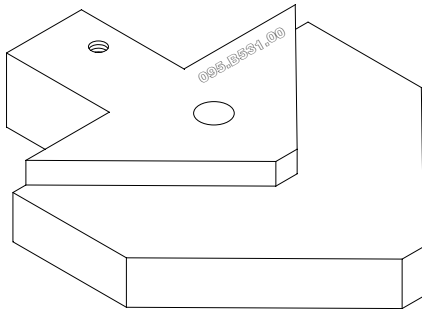

095.B531.00

PERSBLOK
D=20MM L=ST

ENCLUME
D=20MM L=ST

PRESS BLOCK
D=20MM L=ST

PRESSBLOCK
D=20MM L=ST

CP 155
006.1300.XX
006.1340.XX

CP 155-LS
006.1300.XX
006.1340.XX

CS 59Pa
CS 59Pa-CD
CW 50-SC
CP 155-AP
CP 155-LS/AP
CP 96
CP 45Pa
CP 96-AP
Eco system
CW 60-SC

CP 155 / CP 155-LS

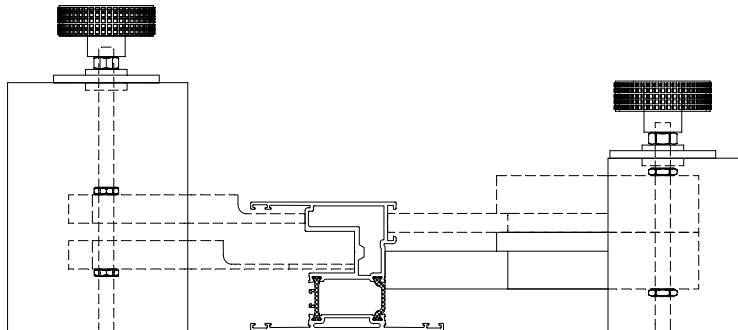

CP 155 CP 155-LS

MACHINES EN TOEBEHOREN
MACHINES ET ACCESSOIRES
MACHINERY AND ACCESSORIES
MASCHINEN UND ZUBEHOER

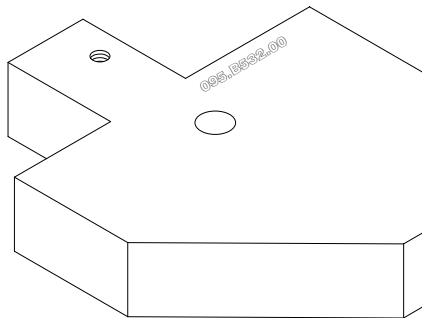

095.B532.00

PERSBLOK
D=30MM L=ST

ENCLUME
D=30MM L=ST

PRESS BLOCK
D=30MM L=ST

PRESSBLOK
D=30MM L=ST

CP 155
006.0320.XX
PS 45
TS 45
CS 38-SL
CS 59Pa
CS 59Pa-SD
CS 59
CS 59-HV
CS 59-SD
CS 68
CS 68-HV
TP 110
TP 138
CW 50
CW 50-HL
CW 60
PR 200
TR 200
MOSQUITO
CR 120
CS 77
CW 86
CW 86-SG
CS 77-HV
CS 77-BP
CW 50-SC
CW 50-SG
CS 38-SL/AP
CP 96
CP 96-LS
CP 96-AP
CP 96-LS/AP

TP 110-Re
EC 50

CP 155

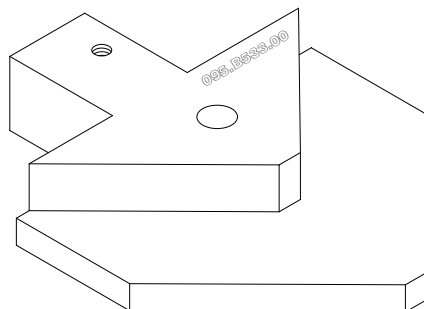
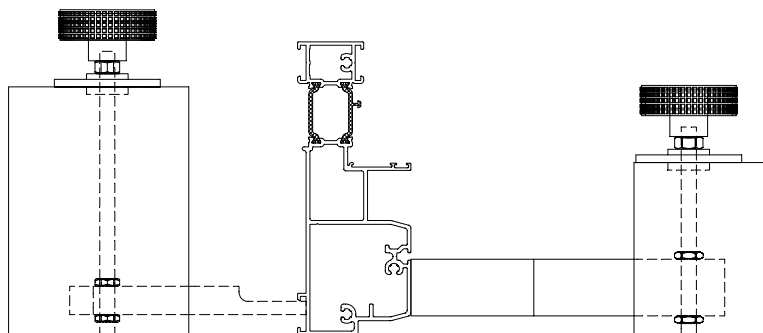

095.B533.00

PERSBLOK
D=11 L=ST-4MM

ENCLUME
D=11 L=ST-4MM

PRESS BLOCK
D=11 L=ST-4MM

PRESSBLOK
D=11 L=ST-4MM

CP 155
006.0320.XX
008.3113.XX
008.3114.XX
008.3120.XX
008.3123.XX
CP 155-LS
008.3113.XX
008.3114.XX
008.3120.XX
008.3123.XX

CW 60
CS 68-FP
CS 77
CS 77-HV
CS 77-BP
CW 50-SC
CP 45Pa
TP 110-Re
CS 77-HI

CP 155

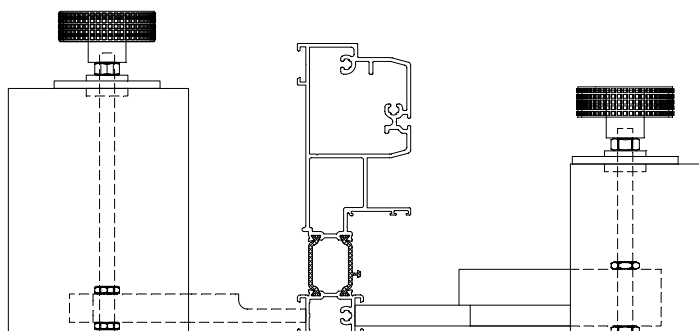

PS 50
TS 50
TS 50-SD
TS 50-MP
TS 57
CS 59Pa
CS 59
CS 59-HV
CS 59-Re
CS 59-So
CS 59-CD
CS 59-SD
CS 68
CS 68-HV
CS 68-Re
CS 68-So
TP 110
TP 138
TLS 110
CW 50
CW 50-1.0

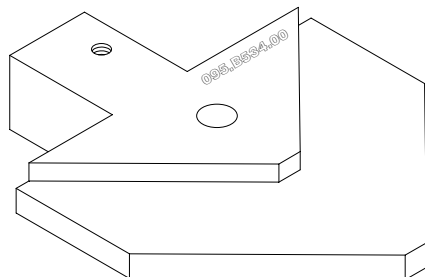

095.B534.00

PERSBLOK
D=10MM L=ST-1.4MM

ENCLUME
D=10MM L=ST-1.4MM

PRESS BLOCK
D=10MM L=ST-1.4MM

PRESSBLOCK
D=10MM L=ST-1.4MM

CP 155
006.1340.XX

CP 155-LS
006.1340.XX

CS 59
CS 68
CS 77
CP 155-AP
CP 155-LS/AP

CP 155 / CP 155-LS

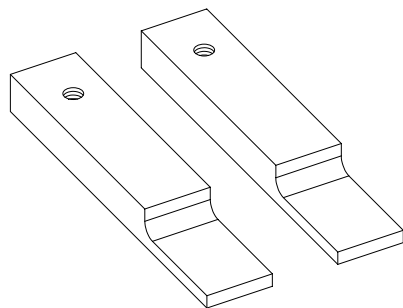
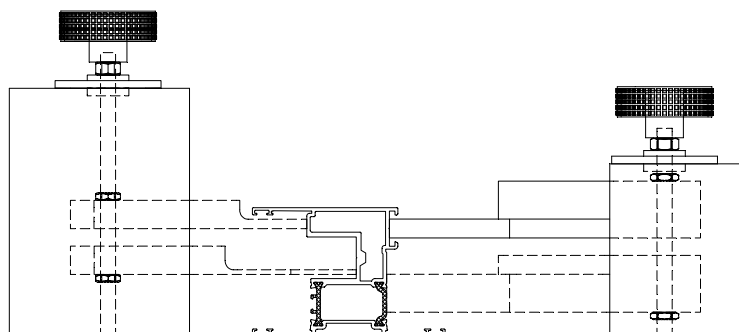

095.B561.00

MESSEN
D=5MM L=ST

COUTEAUX
D=5MM L=ST

KNIVES
D=5MM L=ST

MESSER
D=5MM L=ST

CP 155
006.1340.XX

CP 155-LS
006.1340.XX

CS 59Pa-CD
CS 59-CD
CS 59-SD
MOSQUITO
CW 86
CP 155-AP
CP 155-LS/AP
CW 86-EF
Eco system
CS 38-SL
CS 86-HI
Eco system-AP
CS 38-SL/AP

CP 155 / CP 155-LS

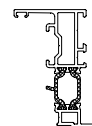
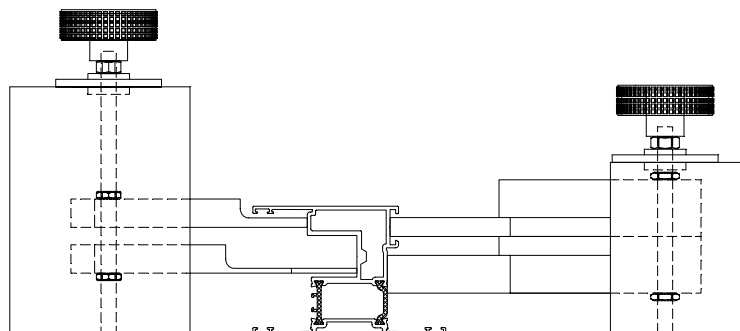

CP 155 CP 155-LS

MACHINES EN TOEBEHOREN
MACHINES ET ACCESSOIRES
MACHINERY AND ACCESSORIES
MASCHINEN UND ZUBEHOER

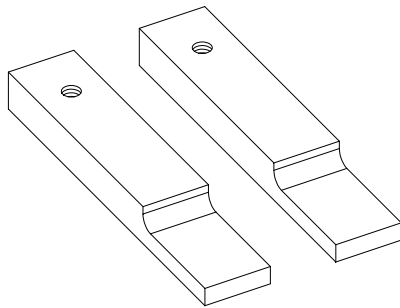

095.B562.00

MESSEN
D=7MM L=ST

COUTEAUX
D=7MM L=ST

KNIVES
D=7MM L=ST

MESSER
D=7MM L=ST

- | | |
|--|---|
| CP 155
006.0320.XX
006.1300.XX
008.3113.XX
008.3114.XX
008.3120.XX
008.3123.XX | TR 200
MOSQUITO
CS 68-FP
CR 120
CS 77
CW 86
CS 77-HV
CS 77-BP
CW 50-SC
CW 50-SG
CS 77-FP
CP 155-AP
CP 155-LS/AP
CP 96
CW 60-DRL
CP 45Pa
CW 86-EF
CP 96-LS
CP 96-AP
CP 96-LS/AP
TP 110-Re
CS 68 Optima
Eco system
CS 38-SL
CS 86-HI
Eco system-AP
CS 38-SL/AP
CS 24-SL
CW 60-SC
CS 24-SL/AP
CW 86-EF/HI
CS 77-Re
Eco System Optima |
| CP 155-LS
006.1300.XX
008.3113.XX
008.3114.XX
008.3120.XX
008.3123.XX | PS 50-SP
CS 59Pa
CS 59Pa-AD
CS 59Pa-SD
CS 59
CS 59-HV
CS 59-Re
CS 59-So
CS 59-SD
CS 68
CS 68-HV
CS 68-Re
CS 68-So
TP 110
TP 138
CW 50
CW 50-HI
CW 50-HL Eco System Optima
CW 60 |

CP 155

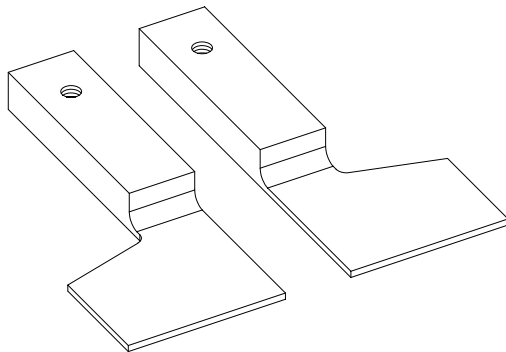
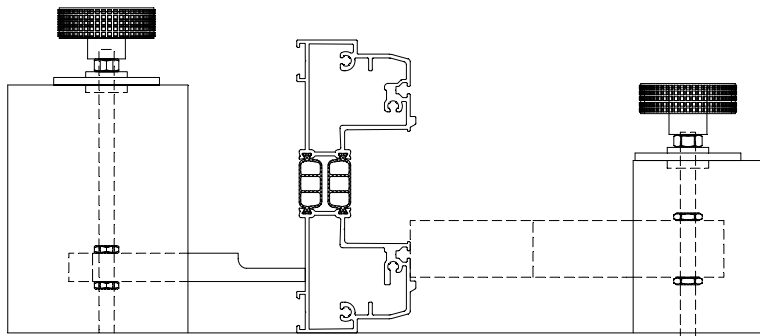

095.B565.00

MESSEN
D=2.5MM L=ST+26.2MM

COUTEAUX
D=2.5MM L=ST+26.2MM

KNIVES
D=2.5MM L=ST+26.2MM

MESSER
D=2.5MM L=ST+26.2MM

- | | |
|---------------------------|--------------------------|
| CP 155
006.1340.XX | CP 155-LS
006.1340.XX |
| CP 155-AP
CP 155-LS/AP | |

CP 155 / CP 155-LS

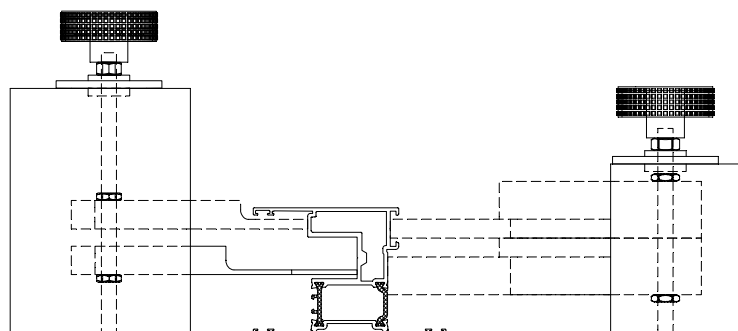

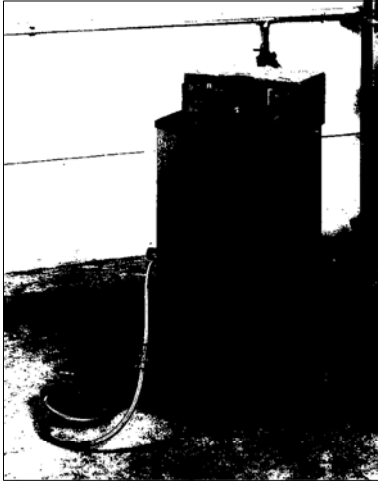

095.30PN.00

SETMATIC MET TOEBEHOREN
SETMATIC

SETMATIC AVEC ACCESSOIRES
SETMATIC

SETMATIC WITH ACCESSORIES
SETMATIC

SETMATIC MIT ZUBEHOER
SETMATIC

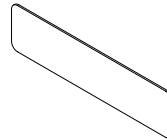
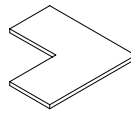
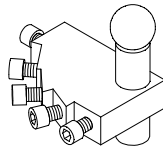
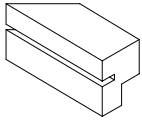

- | | |
|--|---|
| CP 155
006.0320.XX
006.1300.XX
006.1340.XX
008.0114.XX
008.3113.XX
008.3114.XX
008.3120.XX
008.3123.XX | CW 60-SC
CS 24-SL/AP
CW 86-EF/HI
CS 77-Re
Eco System Optima |
| CP 155-LS
006.1300.XX
006.1340.XX
008.3113.XX
008.3114.XX
008.3120.XX
008.3123.XX | |
| PS 50-SP
CS 59Pa
CS 59Pa-AD
CS 59Pa-CD
CS 59Pa-SD
CS 59
CS 59-HV
CS 59-Re
CS 59-So
CS 59-CD
CS 59-SD
CS 68
CS 68-HV
CS 68-Re
CS 68-So
TP 110
TP 138
TLS 110
CW 50
CW 50-HI
CW 50-HL
CW 60
TR 200
MOSQUITO
CS 68-FP
CR 120
CS 77
CW 86
CS 77-HV
CS 77-BP
CW 50-SC
CW 50-SG
CW 60-SG
CS 77-FP
CP 155-AP
CP 155-LS/AP
CP 96
CW 60-DRL
CP 45Pa
CW 86-EF
CP 96-LS
CP 96-AP
CP 96-LS/AP
TP 110-Re
CS 68 Optima
Eco system
CS 38-SL
CS 86-HI
Eco system-AP
CS 38-SL/AP
CS 24-SL | |

CP 155 CP 155-LS

MACHINES EN TOEBEHOREN
MACHINES ET ACCESSOIRES
MACHINERY AND ACCESSORIES
MASCHINEN UND ZUBEHOER

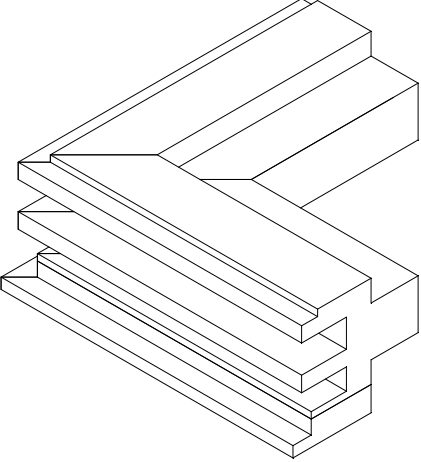
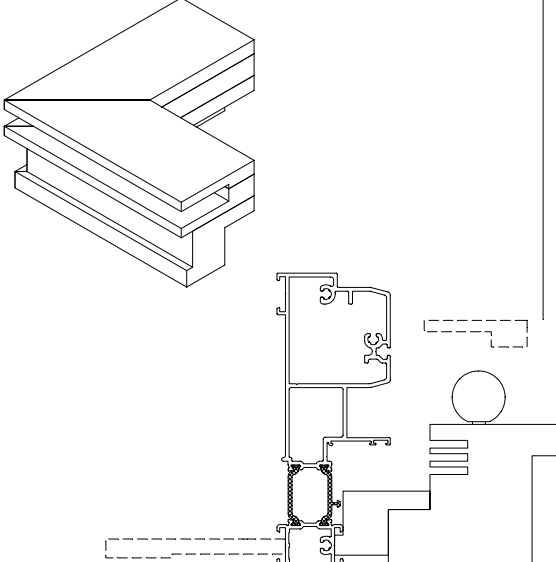
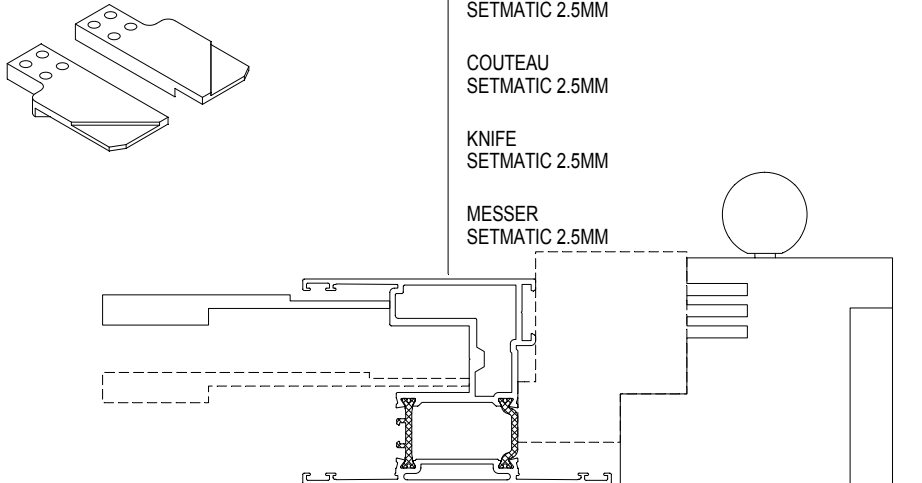

	<p>097.A200.00</p> <p>PERSBLOK CONCEPT</p> <p>ENCLUME CONCEPT</p> <p>PRESS BLOCK CONCEPT</p> <p>PRESSBLOK CONCEPT</p>	<p>CP 155 006.0320.XX 006.1300.XX</p> <p>CP 155-LS 006.1300.XX</p> <p>CS 59 CS 68 CS 68-FP CS 77 CS 77-BP CW 50-SC CP 155-AP CP 155-LS/AP Eco system Eco system-AP CW 60-SC</p>	
	<p>097.C000.00</p> <p>PERSBLOK CONCEPT</p> <p>ENCLUME CONCEPT</p> <p>PRESS BLOCK CONCEPT</p> <p>PRESSBLOK CONCEPT</p>	<p>CP 155 006.0320.XX</p> <p>CS 59 CS 68 CS 68-FP Eco system Eco system-AP</p>	
	<p>097.D000.00</p> <p>MES SETMATIC 2.5MM</p> <p>COUTEAU SETMATIC 2.5MM</p> <p>KNIFE SETMATIC 2.5MM</p> <p>MESSER SETMATIC 2.5MM</p>	<p>CP 155 006.1340.XX</p> <p>CP 155-LS 006.1340.XX</p> <p>CS 59Pa MOSQUITO CP 155-AP CP 155-LS/AP CP 45Pa CS 68 Optima Eco system CS 38-SL Eco system-AP CS 38-SL/AP CS 24-SL CS 24-SL/AP Eco System Optima</p>	

CP 155 CP 155-LS

MACHINES EN TOEBEHOREN
MACHINES ET ACCESSOIRES
MACHINERY AND ACCESSORIES
MASCHINEN UND ZUBEHOER



097.D501.00

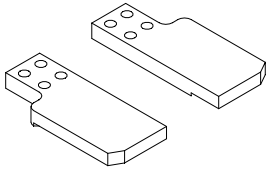

MESSEN
8MM

COUTEAUX
8MM

KNIVES
8MM

MESSER
8MM

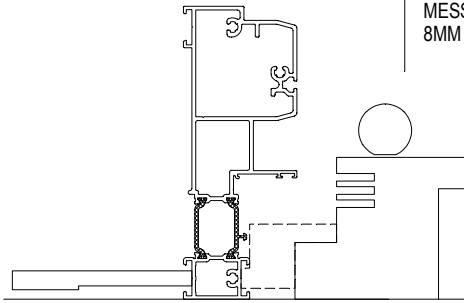

CP 155 006.0300.XX 006.0320.XX 006.1300.XX	CP 96 CP 45Pa CP 96-LS CP 96-AP CP 96-LS/AP CS 68 Optima Eco system CS 38-SL CS 86-HI
CP 155-LS 006.0300.XX 006.1300.XX	Eco system-AP CS 38-SL/AP CS 24-SL CW 60-SC CS 24-SL/AP CW 86-EF/Hi Eco System Optima
CS 59Pa CS 59 CS 68 TP 110 CW 50 CW 50-HL CW 60 CS 77 CS 77-BP CW 50-SC CS 77-FP CP 155-AP CP 155-LS/AP	CS 59-HV CS 59-Re CS 59-So CS 59-CD CS 68-HV

097.E800.00

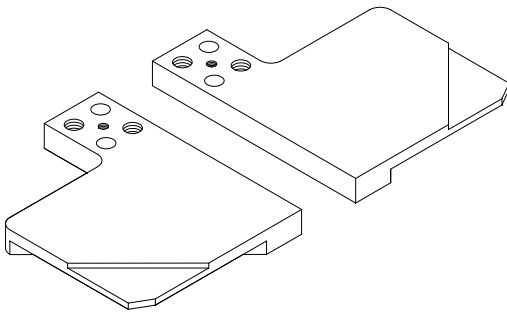

MESSEN
2.5MM

COUTEAUX
2.5MM

KNIVES
2.5MM

MESSER
2.5MM

CP 155 006.0344.XX 006.1340.XX
CP 155-LS 006.1340.XX
CP 155-AP CP 155-LS/AP

CP 155

097.E900.00

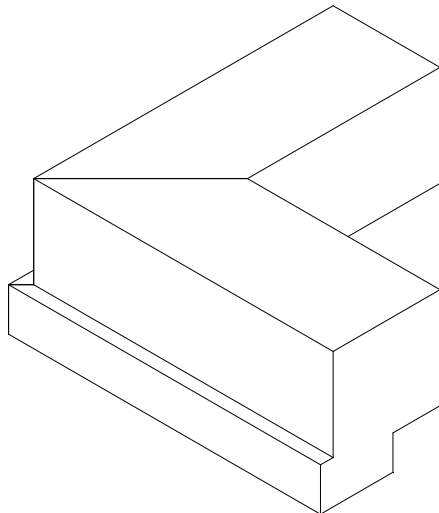

PERSBLOK
CONCEPT

ENCLUME
CONCEPT

PRESS BLOCK
CONCEPT

PRESSBLOCK
CONCEPT

CP 155 006.1340.XX
CP 155-LS 006.1340.XX
CS 59 CS 68 CS 77

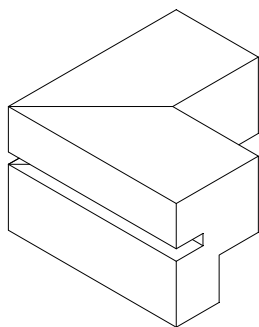

095.30PN.06

PERSBLOK

ENCLUME

PRESS BLOCK

PRESSBLOCK

CP 155-LS
006.0320.XX

CW 50
CW 60
PS 50
TS 50
TS 57
TR 100
TR 200
SWING 50
MOSQUITO

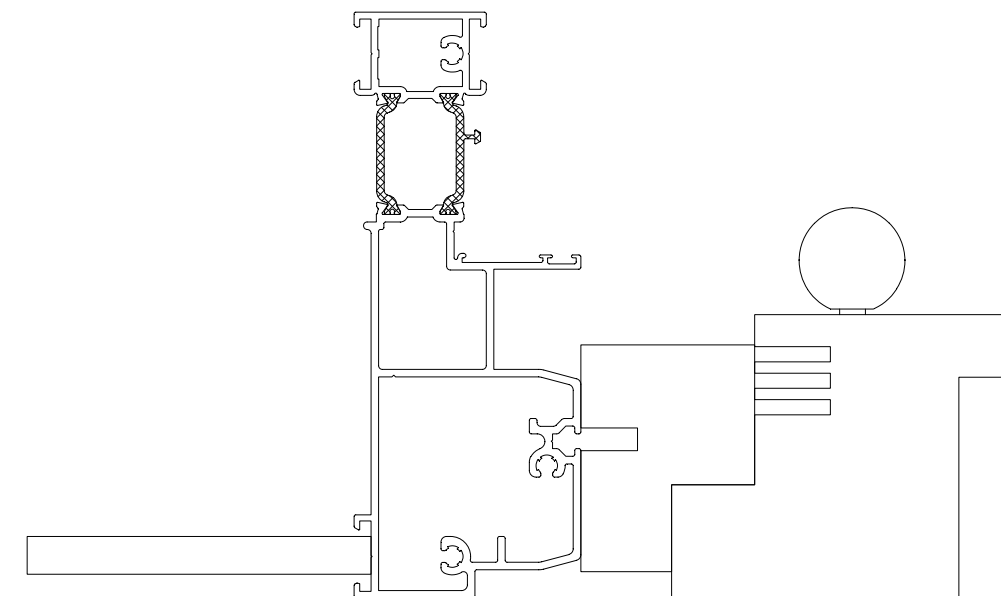

CP 155 CP 155-LS

MACHINES EN TOEBEHOREN
MACHINES ET ACCESSOIRES
MACHINERY AND ACCESSORIES
MASCHINEN UND ZUBEHOER

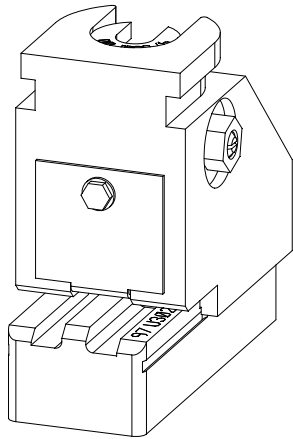

097.U300.00

PONSUNIT WISSELPROFIEL

UNITE D'ETAMPER CHICANE

PUNCH UNIT MEETING SECTION

STANZEINHEIT WECHSELPROFIL

CP 155
CP 155-LS
CP 155-AP
CP 155-LS/AP

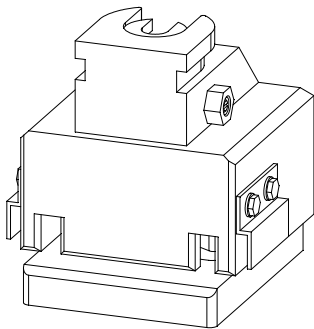
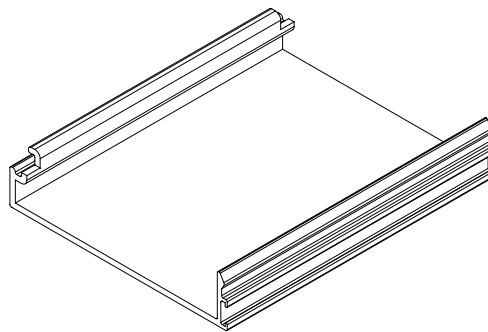
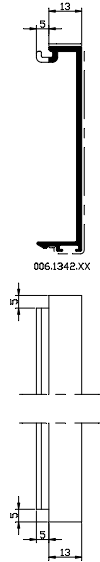
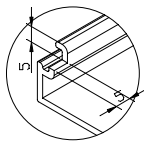

097.U400.00

PONSUNIT WISSELPROFIEL

UNITE D'ETAMPER CHICANE

PUNCH UNIT MEETING SECTION

STANZEINHEIT WECHSELPROFIL

CP 155
CP 155-LS
CP 155-AP
CP 155-LS/AP

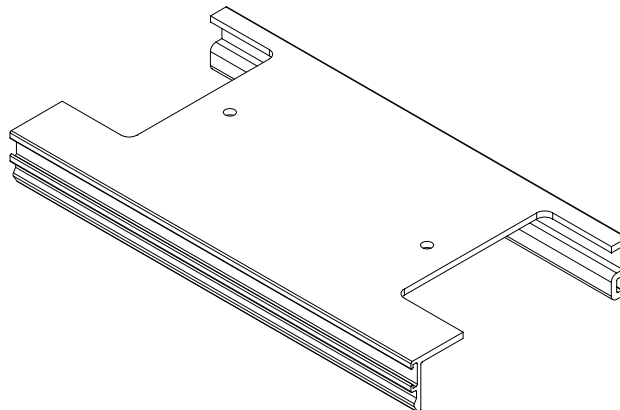
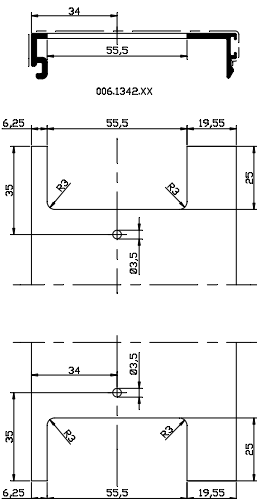

CP 155 CP 155-LS

BOORMALLEN EN MATRIJZEN
CALIBRES DE PERCAGE ET MATRICES
BORING JIGS AND PUNCH TOOLS
BOHRLEHREN UND STANZWERKZEUGE

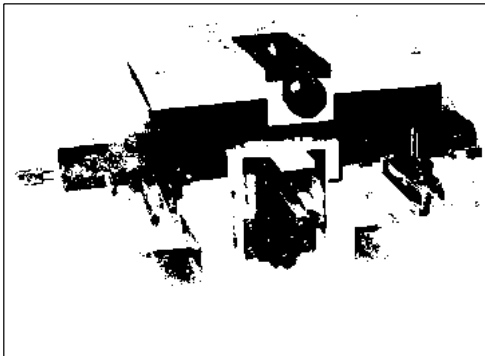

097.F800.00

GELEIDE MATRIJS

MATRICE GUIDEE

PUNCH TOOL

STANZWERKZEUG

CP 155
008.3113.XX

CS 59
CS 59-HV
CS 59-Re
CS 59-So
CS 68
CS 68-HV
CS 68-Re
CS 68-So
TP 110
CS 68-FP
CS 77
OS
CS 77-HV
CS 77-HI

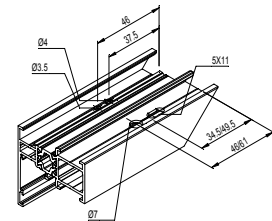
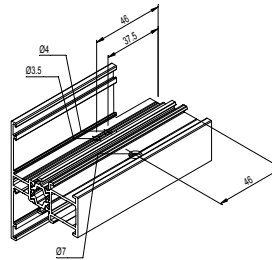

097.F900.00

GELEIDE MATRIJS

MATRICE GUIDEE

PUNCH TOOL

STANZWERKZEUG

CP 155
008.3113.XX
008.3114.XX
008.3120.XX
008.3123.XX
008.3824.XX
0K8.3824.XX

CS 59
CS 59-HV
CS 59-Re
CS 59-So
CS 68
CS 68-HV
CS 68-Re
CS 68-So
TP 110
CS 68-FP
CS 77
OS
CS 77-HV
CS 77-BP
CS 77-HI

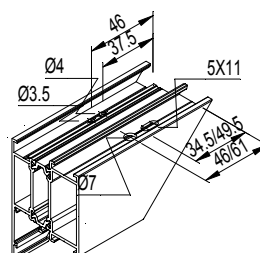
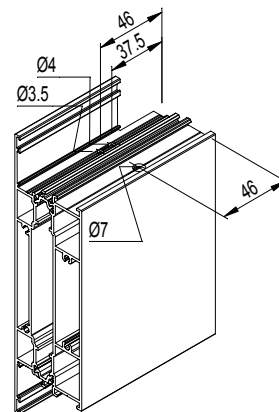



www.reynaers.com